

İçindekiler

Index

Inhaltsverzeichnis



Genel Bilgiler <i>General Info.</i> Einführung	Sembollerin Açıklaması	<i>Key of Symbols</i>	Erklärung der Bezeichnungen	
	Ürün Yelpazesi	<i>Production Range</i>	Produktpalette	04
	K Serisi Redüktörlerin Genel Özellikleri	<i>General Specifications of K Series Gearboxes</i>	Allgemeine Eigenschaften von K Serie Getrieben	06
	Teknik Tanımlamalar	<i>Technical Explanations</i>	Technische Erläuterungen	07
	Teknik Özellikler	<i>Technical Specifications</i>	Technische Informationen	07
	Aksesuarlar	<i>Accessories</i>	Zubehör	08
	Yüzey Koruması	<i>Surface Protection</i>	Oberflächenschutz	08
	Tip Tanımlaması	<i>Unit Designation</i>	Typenbezeichnungen	10
	Örnek Tip Tanımlamaları	<i>Sample Designations</i>	Typenbezeichnungsbeispiele	13
	Motor Büyüklüğüne Göre Geometrik Mümkün Çevrim Oranı Komb. Servis Faktörü	<i>Geomet. Possible Combinations of Ratios According to Motor Size</i>	Geomet. Mögliche Kombi. von Übersetz. nach Motorbaugröße	14
	Yük Sınıflandırması	<i>Load Classification</i>	Belastungsart	17
	Redüktör Dönüş Yönleri	<i>Direction of Rotation</i>	Getriebedrehrichtungen	19
	Radyal Yükler	<i>Overhung Loads</i>	Querkräfte	20
	Radyal Yüklerin Hesabı	<i>Calculation Of Overhung Loads</i>	Berechnung der Querkräfte	21
	Ekstruder Tiplerde Müsade Edilebilir Eksenel Yükler	<i>Permissible Axial Loads for Extruder Types</i>	Zulässige Axialkräfte für Extrudertyp-Getrieben	22
	Eşdeğer Güç Hesabı	<i>Equivalent Power Calculation</i>	Äquivalente Leistung	24
	Eşdeğer Güç Hesabı Örneği	<i>Equivalent Power Cal. Example</i>	Beispiel für äquivalente Leistung	25
	Redüktör Seçimi	<i>Gearbox Selection</i>	Getriebeauswahl	26
	Redüktör Seçim Formu	<i>Gearbox Selection Form</i>	Formular für Getriebeauswahl	28
	Yağlama	<i>Lubrication</i>	Schmierung	31
	Genleşme Tankı	<i>Expansion Tank</i>	Ölgleichsbehälter	32
	Yağ Tipleri	<i>Oil Types</i>	Schmierstoffe	33
	Montaj Pozisyonları	<i>Mounting Positions</i>	Bauformen	34
	Yağ Tapaları	<i>Oil plugs</i>	Ölverschlussschrauben	35
	Yağ Miktarları	<i>Oil Quantities</i>	Ölmengen-Tabellen	35
Motorlar <i>Motors</i> Motoren	AC Motorlar	<i>AC Motors</i>	Drehstrommotoren	39
	a- Genel Özellikler	<i>a- General Spec. of AC Motors</i>	a-Eigensch. des Drehstrommotors	39
	b- Çalışma Türleri	<i>b-Modes of Operation</i>	b-Betriebsarten	40
	c- Koruma Sınıfı	<i>c- Protection Class</i>	c- Schutzarten	41
	d- İzolasyon Sınıfı	<i>d- Insulation Class</i>	d- Isolationsklasse	41

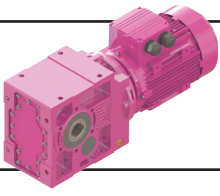

İçindekiler

Index

Inhaltsverzeichnis



	e- Verim Sınıfları	<i>e- Efficiency Classes</i>	e- Energieeffizienzklassen	41
Motorlar <i>Motors</i> Motoren	f- AC Frekans İvertörler	<i>f- AC Frequency Inverters</i>	f- AC Frequenz Umrichter	42
	DC Motorlar	<i>DC Motors</i>	DC Motoren	43
	a- Genel Özellikler	<i>a- General Specif. of DC Motors</i>	a- Eigenschaften von DC Motoren	43
	b- DC Motorların Çalışma İlkeleri	<i>b- Operating principals of DC Motors</i>	b- Funktionsprinzip der DC Motoren	43
	c- DC Motor Çeşitleri	<i>c- Types of DC Motors</i>	c- Arten von DC Motoren	43
	d- DC Motorlarda Hız Kontr.	<i>d- Speed Control of DC motors</i>	d- Drehzahl Kontrolle DC Motoren	43
	Elektromanyetik Frenler	<i>Electromagnetic Brakes</i>	Elektromagnetische Bremsen	44
Frenler <i>Brakes</i> Bremsen	Fren Çeşitleri	<i>Brake Types</i>	Bremsenarten	45
	Fren Bağlantı Şekli	<i>Connection Types</i>	Schaltungsarten	46
	Fren Seçimi	<i>Brake Selection</i>	Bremswahl	46
	Frenin Termik Kapasitesi	<i>The Thermal Capacity of Brake</i>	Therm. Kapazität der Bremsen	47
Güç Devir Tabl. <i>Perform. Tables</i> Leistung- und Drehzahl-Tabellen	Motorlu Güç Devir Tabloları	<i>Geared Motors Performance Tables</i>	Leistung- und Drehzahl-Übersicht von Getriebemotoren	49
	Motorsuz Güç Devir Tabloları	<i>Gear Units Performance Tables</i>	Leistung- und Drehzahl-Übersicht von Getrieben	445
	KR serileri	<i>KR series</i>	KR serie	95
Ölçü Sayfaları <i>Dimension Pages</i> Abmessungstabellen	KN serileri	<i>KN series</i>	KN serie	212
	KV serileri	<i>KV series</i>	KV serie	328
	KT serileri	<i>KT series</i>	KT serie	457
	K...0E Ekstruder Boğazlı Redüktörler	<i>K...0E Extruder Type Gearboxes</i>	K...0E Extruder Getrieben von K Serie	574
	K Serisi Redüktörler için Montaj Önerileri	<i>Mounting Advices for K Serie Gearboxes</i>	Montagevorschläge Für K Serie Getrieben	580
	K serisi Kovan Ölçüleri	<i>K series Hollow Shaft Dimensions</i>	Gehäuseabmessungen von K Serie Getrieben	581
	K...0S Sıkma Bilezikli Redüktörler	<i>K...0S Gearboxes with Shrink Disk Connector</i>	K...0S Serie Hohwelle mit Schrumpfscheibe	582
Mil ve Kovan Ölçüleri <i>Shaft and Hollow Shaft Dimensions</i> Wellen- und Gehäusemaße	Moment Kollu Redüktörler	<i>Gearboxes with Torque Arm</i>	Drehmomentstütze Montagezeichnungen	583
	DIN 5480 Çoklu Kama Ölçüleri	<i>Dimensions of Splined Hollow Shaft to DIN 5480</i>	Abmessungen von Hohlwelle mit Vielkeilverzahnung nach DIN 5408	586
	Opsiyonel Çıkış Flanş Ölçüleri	<i>Optional Output Flange Dimensions</i>	Auswaehlbare Abtriebsflanschdimensionen	587
	Elektrik Motorlarının Performans Değerleri	<i>Electric Motors Ratings and Performance</i>	Elektromotoren Leistungsdaten	589
Motorlar <i>Motors</i> Motor				

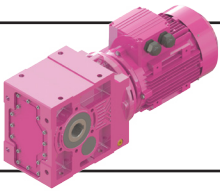

Genel Bilgiler

General Information

Einführung



Sembollerin Açıklaması

c_t: Anahtarın devreye girme zamanı katsayısı

f_s: Servis faktörü

F_{ama}: Çıkış milinde müsaade edilen eksenel yükler [kN]

F_{ame}: Giriş milinde müsaade edilen eksenel yükler [kN]

F_{qam}: Çıkış milinde izin verilen radyal yükler [N]

F_{qem}: Giriş milinde izin verilen radyal yükler [N]

F_{qa}: Çıkış miline gelen radyal yükler [N]

F_{qe}: Giriş miline gelen radyal yükler [N]

F_q: Radyal yönde çıkış miline gelen yükler [N]

F_a: Eksenel yönde çıkış miline gelen yükler [N]

i: Tahvil oranı

J_{ext}: Motor miline indirgenmiş toplam dış atalet momenti [kgm²]

M_2: Çıkış momenti [Nm]

M_a: Anma momenti [Nm]

n_1: Redüktör giriş mili devri [d/dak]

n_2: Redüktör çıkış mili devri [d/dak]

P_{eq}: Eşdeğer güç [kW]

P_e: Nominal güç (Bak. Güç-Devir Tabloları) [kW]

P_M: Tahrik edilecek makina için gerekli güç (Değişken yükler için eşdeğer güç alınır) [kW]

t: Zaman [s]

T_e: Eşdeğer moment [Nm]

Key of Symbols

c_t: Coefficient of switch on time.

f_s: Service factor

F_{ama}: Permissible axial loads which can be applied to output shafts [kN]

F_{ame}: Permissible axial loads which can be applied to input shafts [kN]

F_{qam}: Permissible overhung loads which can be applied to output shafts [N]

F_{qem}: Permissible overhung loads which can be applied to input shafts [N]

F_{qa}: Overhung loads applied to the output shaft [N]

F_{qe}: Overhung loads applied to the input shafts [N]

F_q: Overhung loads on output shaft [N]

F_a: Axial loads on output shaft [N]

i: Transmission ratio

J_{ext}: Total outside moment of inertia reduced to the motor shaft [kgm²]

M_2: Output torque [N]

M_a: Nominal torque [Nm]

n_1: Input speed of gearbox [rpm]

n_2: Output speed of gearbox [rpm]

P_e: Equivalent power [kW]

P_N: Nominal power (given on performance tables) [kW]

P_M: Power consumption of the driven machine (for alternating power, refer to equivalent power) [kW]

t: Time [s]

T_e: Equivalent torque [Nm]

Erklärung der Bezeichnungen

c_t: Koeffizient der Betätigung von Schalter

f_s: Betriebsfaktor

F_{ama}: Zulässige Axialkräfte auf Abtriebswelle [kN]

F_{ame}: Zulässige Axialkräfte auf Antriebswelle [kN]

F_{qam}: Zulässige Querkräfte auf Abtriebswelle [N]

F_{qem}: Zulässige Querkräfte auf Antriebswelle [N]

F_{qa}: Querkräfte auf Abtriebswelle [N]

F_{qe}: Querkräfte auf Antriebswelle [N]

F_q: Querkräfte auf Abtriebswelle [N]

F_a: Axialkräfte auf Abtriebswelle [N]

i: Übersetzungsverhältnis

J_{ext}: Die Gesamtträgheit der rotierende Teile von der Ausgangsseite reduziert auf Motorwelle [kgm²]

M_2: Ausgangsdrehmoment [N]

M_a: Nenndrehmoment [Nm]

n_1: Antriebsdrehzahl [U/min]

n_2: Abtriebsdrehzahl [U/min]

P_e: Äquivalente Leistung [kW]

P_N: Getriebe Nennleistung (siehe Leistung- Drehzahl tabellen) [kW]

P_M: Benötigte Leistung an der Abtriebswelle (Zur Berechnung bei variablen Leistungen äquivalente Leistung benutzen) [kW]

t: Zeit [s]

T_e: Minimales Drehmoment [Nm]

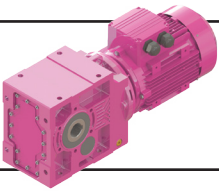

Genel Bilgiler

General Information

Einführung



Ürün Yelpazesi

Elinizdeki katalog sadece **K serisi** ürünleri içermektedir.

- M ve N Serisi

Helisel alın dişliye sahip, giriş ve çıkış milleri aynı düzlem üzerinde ve birbirine paralel uzanan, üzerlerinde bulunan ayak veya flanş ile makina-ya sabitlenen redüktörlerdir. Dolu mil çıkışlıdır.

- D Serisi

Helisel alın dişliye sahip, giriş ve çıkış milleri aynı düzlem üzerinde, birbirine paralel ve belirli bir aralıkta yerleştirilmiş, iki yan yüzde bulunan bağlantı civataları, flanş veya tork kolu ile makina-ya sabitlenen redüktörlerdir. Delik milli veya mil çıkışlı olabilir.

- E Serisi

Sonsuz vida ve çark dişlili, belirli bir aralıkta ve birbirine dik konumlandırılmış giriş ve çıkış millerine sahip, çepçevre konumlandırılmış ayak bağlantıları, flanş veya tork kolu ile makina-ya sabitlenebilen redüktörlerdir. Delik milli veya mil çıkışlı olabilir.

- Y Serisi

Yatık tip redüktörler, ağır şartlarda çalışmak üzere dizayn edilmiş redüktör tipleridir. Bu tiplerde redüktör ile bunu tahrik eden mekanizma arasında değişik bağlantı şekilleri mevcuttur (Mekanik ve hidrolik kaplinler, çeşitli tip kayışlar ve zincirle tahrik gibi). Delik milli veya mil çıkışlı olabilir.

- K Serisi

Helisel alın dişli ve konik dişlilerden oluşan, birbirine dik ve belirli bir aralıkta konumlandırılmış giriş ve çıkış miline sahip, çepçevre sunulan ayaklar, flanş veya tork kolu ile makina-ya sabitlenen redüktörlerdir. E serisinden farklı olarak yüksek verime sahiptirler. Delik milli veya mil çıkışlı olabilir.

- H ve B Serisi

Helisel ve/veya konik dişliye sahip ağır hizmet tipi redüktörlerdir. Giriş ve çıkış milleri birbirine paralel veya dik olabilir. Her yönden bağlantı için ayak bağlantıları bulunur. Opsiyonel olarak flanş ile de bağlanabilir. Delik milli veya mil çıkışlı olabilir.

- T Serisi

T Serisi redüktörler helisel dişli iki kademe motorsuz delik milli redüktörlerdir. T Serisi redüktörler delik milli olması ve kompakt gövde yapısı sayesinde daha küçük hacimli alanlara montajı yapılabilmektedir.

- P ve R Serisi

P ve R Serisi redüktörler planet dişli redüktörlerdir. Endüstriyel ve mobil uygulamalarda kullanılırlar. Diğer redüktör tiplerine göre daha küçük hacimde daha büyük tork iletebilirler.

- V Serisi

V vinç redüktörleri M1 - M8 (1Dm - 5m) vinç sınıflarına uygun olarak, çift veya sabit devirli frenli motorlarla üretilebilmektedir.

Production Range

This catalogue is containing K series of gearboxes only.

- M and N Series

M and N series are helical geared gear units. The input and output shafts are parallel to each other and on the same plane. The gearbox can be connected to the machine by using the foot or flange on the gearbox. Has solid output shaft.

- D Series

D series are helical geared gearboxes with parallel input and output shafts. The shafts have a distance in between and located on the same plane. The gearbox can be assembled to the machine by using, the connection screws on the sides, flange or torque arm on the gearbox. Can have hollow or solid output shaft.

- E Series

E series gearboxes are with worm and worm-wheel. The input and output shafts are perpendicular to each other and have a distance in between. It can be assembled to the driven machine by the use of the foot, flange or torque arm on the gearbox. Can have hollow or solid output shaft.

- Y Series

Horizontal type gearboxes are designed to operate in heavy conditions. In these types there are a lot of combination forms between gearbox and driver (for example, mechanic and hydraulic couplings, various belt and chain drives etc.). Can have hollow or solid output shaft.

- K Series

These are gearboxes with helical and bevel gears. The input and output shafts are perpendicular to each other and have a distance in between. It can be assembled to the driven machine using the foot, flange or torque arm on the gearbox. They have high efficiency compared to E series. Can have hollow or solid output shaft.

- H and B Series

These gearboxes are helical or/and bevel geared industrial gearboxes. The input and output shafts can be arranged parallel or perpendicular to each other. The gearbox can be assembled by the use of the foot connections on each side. Flange connections are optional. They can have hollow or solid output shaft.

- T Series

T Series are gear units which are helical geared, two staged, hollow shaft mounted gear units and manufactured according to monoblock principal. T Series gearboxes have hollow shaft and compact housing so that T series can be mounted on smaller places.

- P and R Series

P and R Series gearboxes are planetary gearboxes. They are mostly used by industrial and mobile applications. Planetary gearboxes can transfer high torques in small volumes compared to other gearboxes.

- V Series

V hoist drives are produced according to M1 - M8 (1Dm - 5m) crane classes.

Produktpalette

Dieses Katalog umfasst nur die **K Serie** Getriebe.

- M und N Serie

Diese Modelle sind Stirnradgetriebe mit parallelen Antriebs- und Abtriebswelle auf einer Ebene. Die Getriebe werden mit Fuß- oder Flanschverbindung an die angetriebene Maschine angekoppelt. Hat Vollwelle am Ausgang.

- D Serie

Diese Getriebe sind Stirnradgetriebe mit paralleler Antriebs- und Abtriebswelle, die auf einer Ebene liegen und einen Abstand zueinander haben. Diese Getriebe wird seitlich mit Gewindelöchern am Maschine oder mit einer Flansch verbindet. Kann Voll- und Hohlwelle am Ausgang haben.

- E Serie

Diese Getriebe bestehen aus Schnecke und Schneckenrad. Die Antriebs- und Abtriebswellen sind senkrecht zueinander und haben einen bestimmten Abstand. Das Getriebe wird mit Fußbefestigung, Flanschverbindung oder mit Drehmomentstütze an die angetriebene Maschine montiert. Kann Voll- und Hohlwelle am Ausgang haben.

- Y Serie

Diese Getriebe sind für Einsatz unter schweren Bedingungen ausgelegt. Bei dieser Ausführung gibt es sehr viele verschiedene Verbindungsmöglichkeiten zwischen Antrieb und Getriebe (Zum Beispiel; mechanische und hydraulische Kupplungen, Riementrieb, Kettentrieb usw.). Kann Voll- und Hohlwelle am Ausgang haben.

- K Serie

Diese Getriebe bestehen aus Stirnräder und Kegelhäder. Die Antrieb und Abtriebswellen sind senkrecht und haben einen Abstand zueinander. Das Getriebe wird mit Fußbefestigung, Flanschverbindung oder Drehmomentstütze an die angetriebene Maschine montiert. Der Wirkungsgrad ist wesentlich höher als E Serie. Kann Voll- und Hohlwelle am Ausgang haben.

- H und B Serie

Diese Getriebe sind geeignet für industrielle Anwendungen und haben parallelen oder senkrechten Antrieb und Abtriebswelle auf einer Ebene. Das Getriebe kann mit Füßen, die auf jede Seite der Getriebe vorhanden sind, oder optional mit Flansch an die angetriebene Maschine montiert werden. Kann Voll- und Hohlwelle am Ausgang haben.

- T Serie

T Serien Getriebe sind zwei stufige, schrägverzahnte Hohlwellenflachgetriebe in Monoblockgehäuse. Die T Serie hat eine kompakte Gehäuse und ist serienmäßig mit Abgangshohlwelle hergestellt, so dass das Getriebe minimalen Platzbedarf hat.

- P und R Serie

P und R Serie sind Planetengetriebe, die vielseitig im Industrie und bei mobiler Anwendungen einsetzbar sind, mit Planetenzahnräder. Planetengetriebe können im Vergleich zu anderen Getrieben größere Drehmomente bei kleineren Bauvolumen übertragen.

- V Serie

V Krane und Hebezeuge werden geeignet zur Kranklasse M1 - M8 (1Dm - 5m) hergestellt.

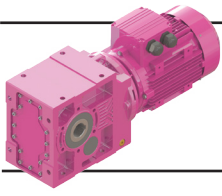

Genel Bilgiler General Information Einführung

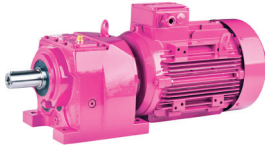

M ...

13 farklı büyüklükte;
Moment aralığı: 50 - 18.000 Nm
Devir aralığı: 0,1 - 500 d/dak
13 different sizes:
Torque range: 50 - 18.000 Nm
Speed range: 0,1 - 500 rpm
13 verschiedene Baugrößen:
Drehmomentbereich: 50 - 18.000 Nm
Drehzahlbereich : 0,1 - 500 U/min

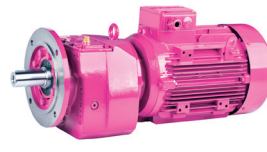

N ...

13 farklı büyüklükte;
Moment aralığı: 50 - 18.000 Nm
Devir aralığı: 0,1 - 500 d/dak
13 different sizes:
Torque range: 50 - 18.000 Nm
Speed range: 0,1 - 500 rpm
13 verschiedene Baugrößen:
Drehmomentbereich: 50 - 18.000 Nm
Drehzahlbereich : 0,1 - 500 U/min

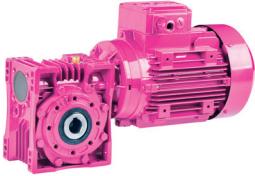

E ...

8 farklı büyüklükte;
Moment aralığı: 5 - 1.000 Nm
Devir aralığı: 0,1 - 400 d/dak
8 different sizes:
Torque range: 5 - 1.000 Nm
Speed range: 0,1 - 400 rpm
8 verschiedene Baugrößen:
Drehmomentbereich: 5-1.000 Nm
Drehzahlbereich : 0,1-400 U/min

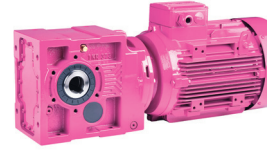

K ...

12 farklı büyüklükte;
Moment aralığı: 200 - 20.000 Nm
Devir aralığı: 0,1 - 400 d/dak
12 different sizes:
Torque range: 200 - 20.000 Nm
Speed range: 0,1 - 400 rpm
12 verschiedene Baugrößen:
Drehmomentbereich: 200 - 20.000 Nm
Drehzahlbereich : 0,1 - 400 U/min

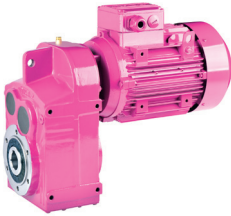

D...

11 farklı büyüklükte;
Moment aralığı: 150 - 18.000 Nm
Devir aralığı: 0,1 - 350 d/dak
11 different sizes:
Torque range: 150 - 18.000 Nm
Speed range: 0,1 - 350 rpm
11 verschiedene Baugrößen:
Drehmomentbereich: 150 - 18.000 Nm
Drehzahlbereich : 0,1 - 350 U/min



Y ...

25 farklı büyüklükte;
Moment aralığı: 1200 - 43000 Nm
Devir aralığı: 2,6 - 990 d/dak
25 different sizes:
Torque range: 1200 - 43000 Nm
Speed range: 2,6 - 990 rpm
25 verschiedene Baugrößen:
Drehmomentber. :1200-43000 Nm
Drehzahlbereich : 2,6-990 U/min

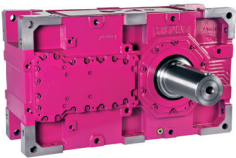

H ...

20 farklı büyüklükte;
Moment aralığı: 2.500 - 470.000 Nm
Devir aralığı: 0,1 - 250 d/dak
20 different sizes:
Torque range: 2.500 - 470.000 Nm
Speed range: 0,1 - 250 rpm
20 verschiedene Baugrößen:
Drehmomentber. :2.500 - 470.000 Nm
Drehzahlbereich : 0,1 - 250 U/min

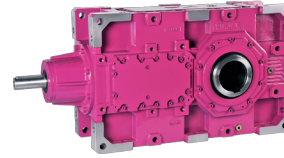

B ...

20 farklı büyüklükte;
Moment aralığı: 5.000 - 470.000 Nm
Devir aralığı: 0,1 - 115 d/dak
20 different sizes:
Torque range: 5.000 - 470.000 Nm
Speed range: 0,1 - 115 rpm
20 verschiedene Baugrößen:
Drehmomentber. :5.000-470.000 Nm
Drehzahlbereich : 0,1-115 U/min



P ...

10 farklı büyüklükte;
Moment aralığı: 1.000 - 50.000 Nm
Tahvil oranları: 3,5 - 3000 arası
10 different sizes:
Torque range: 1.000 - 50.000 Nm
Transmission ratio: 3,5 - 3000
10 verschiedene Baugrößen:
Drehmomentber. : 1.000 - 50.000 Nm
Übersetzung: 3,5 - 3000

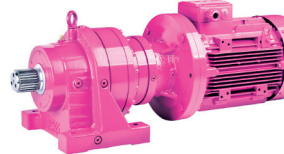

R ...

10 farklı büyüklükte;
Moment aralığı: 1.000 - 50.000 Nm
Tahvil oranları: 3,5 - 3000 arası
10 different sizes:
Torque range: 1.000 - 50.000 Nm
Transmission ratio: 3,5 - 3000
10 verschiedene Baugrößen:
Drehmomentber. : 1.000 - 50.000 Nm
Übersetzung: 3,5 - 3000



T ...

10 farklı büyüklükte;
Moment aralığı: 200 - 18.000 Nm
Devir aralığı: 46 - 280 d/dak
10 different sizes:
Torque range: 200-18.000 Nm
Speed range: 46-280 rpm
10 verschiedene Baugrößen:
Drehmomentber. :200-18.000 Nm
Drehzahlbereich : 46-280 U/min

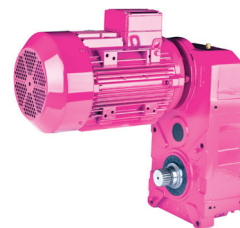

VR ...

VR vinç redüktörleri
M1 - M8 ,(1Dm - 5m) yük sınıfı
ISO 4301 / 1 ,(FEM 1.001 / III)
VR Hoist Drive Units
M1 - M8 ,(1Dm - 5m) load classification
ISO 4301 / 1 ,(FEM 1.001 / III)
VR Kran und Hebezeug Getriebe
M1 - M8 ,(1Dm - 5m) Belastungsart
ISO 4301 / 1 ,(FEM 1.001 / III)

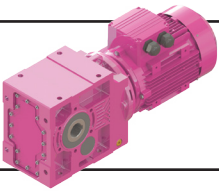

Genel Bilgiler

General Information

Einführung



K Serisi Redüktörlerin Genel Özellikleri

K Serisi redüktörler, helisel konik dişli monoblok gövde yapısındaki redüktörlerdir. Giriş ve çıkış milleri 90° olması gereken durumlarda yüksek verim ve mukavemetin gerektirdiği yerler için dizayn edilmiştir.

K Serisi redüktörler E serisinin çok yönlü bağlantı opsiyonları ile M serisinin monoblok ve yüksek verim özellikleriyle birlikte yüksek momente sahip olarak üretilmektedir. Redüktörlerin giriş motor bağlantılarında IEC B5 veya B14, standart akuple veya motorsuz mil girişli gibi esnek montaj opsiyonları kullanılmaktadır.

K serisi redüktörler monoblok gövde içerisinde; küçük gövdeler 2 ve 3 kademe, büyük gövdeler 3 kademe olarak üretilmektedir. Yüksek redüksiyon gerektiren yerlerde 6 kademeye kadar akuple edilerek temin edilebilir.

YILMAZ REDÜKTÖR olarak tasarım prensibimiz;

- Yüksek teknoloji kullanmak
- Güvenilirlik,
- Yüksek güç yoğunluğu,
- Yüksek verim,
- Montaj uyumluluğu,
- Esnek çözümler

Dikkat Edilecek Hususlar !

- Bu katalogta verilen resimler görsel amaçlıdır ve şekilsel detaylar bağlayıcı değildir.

- YILMAZ REDÜKTÖR, ürünler ve kataloglar üzerinde, müşterileri bilgilendirmeksizin her türlü değişikliği yapma hakkına sahiptir.

- Ürünler teslim alındıktan sonra ürünle birlikte verilen kullanım kılavuzu okunmadan sistem devreye alınmamalıdır.

- Katalogta verilen yağ miktarları referans amaçlıdır. Gerçek yağ seviyesi için redüktör üzerinde bulunan yağ seviye tapası kullanılmalıdır. Yağ viskozitesi için, redüktör etiketine bakınız.

- Sipariş anında montaj pozisyonu bildirilmeyen redüktörler **M1** montajına uygun sevk edilir. Etiketle yazan montaj pozisyonundan farklı bağlanan redüktörler garanti kapsamından çıkar. Bu katalogta verilen redüktör ağırlıkları ortalama ağırlık değerleridir. Tahvil oranına ve üzerinde bağlı olan aksesuara göre ağırlıklar farklılık gösterebilir.

General Specifications of K Series Gearboxes

K Series gearboxes are helical-bevel geared monoblock housing gearboxes. K Series are designed for higher efficiency and higher strenght required operations. Input and output shafts are perpendicular to each other.

K Series gearboxes have advantages of E Series mounting options, monoblock housing and higher efficiency advantages of M series with higher torque capabilities. K Series have flexible connection possibilities which is IEC B5 or B14 connection, directly mounted or solid input shaft options .

Small sizes of K series gearboxes can be 2 and 3 stages. Bigger sizes are manufactured only 3 stages in monoblock housing. K series supplied for high reduction operations up to 6 stages by using double housings.

As we are YILMAZ REDÜKTÖR,our design principals are;

- Using high technology*
- Reliability*
- High power density*
- High efficiency*
- Mounting compatible*
- Flexible solutions*

Attention to the following points !

- Drawings are examples only and the details on the drawings or illustrations are not strictly binding.

- YILMAZ REDÜKTÖR reserve the right to make all kinds of changes in products and catalogues without any notice.

- Prior to commissioning, the operating instructions provided with the gearbox must be observed.

- Oil quantities given are guide values only. The exact quantity of oil should be checked by using the provided oil level plugs according mounting positions. For correct oil viscosity refer to the nameplate.

*- If the mounting position is not informed upon ordering, the gear unit is delivered according **M1** mounting position. A different operation then the indicated mounting position on the name plate cancels the warranty. The weights given in this catalogue are mean values. Depending on the ratio and accessories the weights can differ.*

Allgemeine Eigenschaften von K Serie Getrieben

K Serie Getriebe sind Kegelradgetriebe mit Monoblok-Gehäuse. Eingang- und Ausgangswelle sind senkrecht zueinander. Diese Getriebe sind für Einsatzgebiete geeignet bei denen ein hoher Wirkungsgrad und eine hohe Festigkeit benötigt werden.

K Serie Getriebe haben umfangreiche Montagemöglichkeiten, wie E Serie, hohe Momenttragbarkeit mit hohem Wirkungsgrad und Monoblok-Gehäuse, wie M Serie, als Vorteil. Standart Motorverbindung (IEC B14 oder B5) oder Wellenantrieb ist möglich.

Kleine K-Serie Getriebe können mit zwei oder drei Stufen in einem Monoblock-Gehäuse hergestellt werden, wobei große K Serie Getriebe nur mit drei Stufen ebenfalls in einem Monoblock-Gehäuse hergestellt werden. K serien Getriebe können für hohe Untersetzungen mit Hilfe eines zusätzlich gekoppelten Gehäuses bis zu sechs Stufen produziert werden.

Als YILMAZ REDÜKTÖR unsere Entwurfsprinzipien sind;

- Verwenden von hohen Fertigungstechnik
- Hohe Betriebssicherheit
- Leistungsdichte
- Hoher Wirkungsgrad
- Universale Montagemöglichkeit
- Sonderlösungen

Bitte folgende Punkte beachten !

- Die Abbildungen sind beispielhaft und nicht verbindlich.

- Alle-Änderungen auf dem Katalog und an der Produkte bleiben vorbehalten und können ohne Kenntnisnahme erfolgen.

- Vor Inbetriebnahme ist die mit gelieferter Betriebsanleitung zu beachten.

-Angaben über Ölmengen sind unverbindlich. Maßgebend ist die Ölstandsschraube in der geeigneten Montageposition. Ölviskosität und Sorte muss den Angaben des Typenschildes entsprechen.

- Wenn die Bauform bei Bestellung nicht angegeben ist, erfolgt die Lieferung in der Bauform **M1**. Wenn die Getriebe anders als auf dem Typenschild benannte Bauform eingesetzt werden, verliert die Garantie ihre Gültigkeit. Die angegebenen Gewichte sind unverbindliche Mittelwerte ohne Zubehör; genauere Gewichte sind abhängig von Zubehör und Übersetzung.

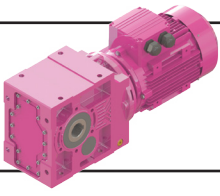

Genel Bilgiler

General Information

Einführung



Teknik Tanımlamalar

- Çıkış Momenti (M_2): [Nm]

Motorun verdiği momentin tahvil oranı ve verimle ile çarpılarak elde edilen değerdir. Redüktörün çıkışından alınabilecek moment gösterir.

- Anma Momenti (M_a): [Nm]

Redüktörün $f_s=1$ şartı için mekanik olarak taşıdığı moment değeridir.

- Nominal Güç (P_n): [kW]

Nominal güç, redüktörün $f_s=1$ şartı için mekanik olarak taşıyabileceği güç değeridir. Redüktörlerin nominal güçleri, güç devir tablolarında verilmiştir.

- Çevrim oranı (i):

Redüktörün giriş devrinin çıkış devrine oranıdır. Yılmaz Redüktör K serisi redüktörlerde 3,5-23500 arasında değişen çevrim oranları mevcuttur.

- Eşdeğer Güç ve Moment

P_{eq} [kW], T_e [Nm]

Sabit devir altında ancak değişken yük değerlerinde çalışan redüktörlerde, sabit yük altında çalışma şartlarına eşdeğer gelen moment ve güç değerleridir. Hesaplama yöntemi sayfa 23'de verilmiştir.

- İhtiyaç güç (P_M): [kW]

Redüktörlerin kullanılacağı uygulamanın istenilen şekilde çalışabilmesi için ihtiyaç duyduğu güç değeridir.

- İhtiyaç moment (T): [Nm]

Redüktörün kullanılacağı uygulamanın çalışabilmesi için ihtiyaç duyduğu moment değeridir. Seçilen redüktör için her zaman çıkış momentini eşit yada daha düşük olmalıdır.

- Müsade Edilen Eksenel ve Radyal Yükler

Fqem, Fqam: [N]

Redüktörün giriş veya çıkış milinde müsade edilen eksenel ve radyal yüklerdir.

- Servis Faktörü (f_s):

Redüktörün çalıştığı şartlar ile uyumlu olması için gerekli olan emniyet katsayısıdır. $f_s=1$, düzgün ve sakin yüklerde, günlük sekiz saat, saatte 100 dur-kalk çalışmayı karşılar. Detaylar için redüktör seçim bölümüne bakınız.

Teknik Özellikler:

- Ses seviyesi:

Redüktörlerimizin ses seviyesi VDI 2159' da verilen redüktörler için müsade edilen ses seviyelerinin altındadır.

- Boya ve Korozyon Koruması:

Redüktörlerin standart rengi DIN1843'e göre RAL 7031 dir. İstek üzerine farklı renklerde boyanabilir. Nemli ve korozif bölgeler için istek üzerine farklı boya uygulanabilir.

Technical Explanations

- Output Torque (M_2): [Nm]

Multiplication of motor output torque with transmission ratio and efficiency gives the result of output torque at the output shaft of the gear unit.

- Nominal Torque (M_a): [Nm]

Nominal torque is the mechanical torque which the gearbox can resist under $f_s=1$ conditions.

- Nominal Power (P_n): [kW]

The nominal power is the power which gearbox can mechanically resist under $f_s=1$ condition. The nominal powers are given on the performance tables.

- Ratio (i):

Ratio between output shaft speed and input shaft speed. Available ratios of Yılmaz Redüktör K series are between 3,5 to 23500.

- Equivalent Power and Torque

P_{eq} : [kW], T_e [Nm]

For gearbox unit with constant speed but variable working conditions: This is the calculated power or torque which is equivalent to the values at working under constant working conditions.

- Required Power (P_M): [kW]

Required power for the applications which is able to drive the system.

- Required Torque (T): [Nm]

Required torque for applications. Required torque always must be equal or smaller than output torque for selected gearbox.

- Permissible Axial and Overhung Loads:

Fqem, Fqam [N]

Permissible axial and overhung load at the output or input shaft of gearboxes.

- Service Factor (f_s):

Service factor is a safety coefficient, which takes into account the different running conditions of the driven machine. $f_s=1$ is used for uniform loads 8 hours working per day and up to 100 cycle per hour.

Technical Specifications:

- Noise Level:

The noise level of our gearboxes is below the permitted values defined in VDI guidelines 2159 for gear units.

- Coating and Corrosion Protection:

The gearboxes are painted with RAL 7031 according DIN1843. Different colors are available upon request. Paintings for high humidity or chemically aggressive environments are available upon request.

Technische Erläuterungen

- Ausgangsmoment (M_2): [Nm]

Multiplikation von Ausgangsmoment des Motors mit Übersetzung und Division das Ergebnis mit Wirkungsgrad ergibt den Betrag von Ausgangsmoment der Getriebe.

- Nennmoment (M_a): [Nm]

Mechanisches Belastungsmoment der Getriebe unter der Bedingung $f_s=1$.

- Nennleistung (P_n): [kW]

Die Nennleistung ist die mechanische Grenzfestigkeitsleistung für $f_s=1$. Kann von der Leistung-Drehzahltable abgelesen werden.

- Übersetzung (i):

Wird aus dem Verhältnis von Ausgang- zu Eingangswinkelgeschwindigkeit bestimmt. Gängige Übersetzungen von Yılmaz K Serie Getriebe liegt zwischen 3,5 bis 23500.

- Äquivalente Leistung und Moment

P_{eq} : [kW], T_e [Nm]

Für mit konstanten Drehzahl aber unter veränderlichen Betriebsbedingungen arbeitende Getriebe berechnete Leistung und Moment äquivalent zu Werten beim Arbeiten unter konstanten Betriebsbedingungen.

- Notwendige Leistung (P_M): [kW]

Für das Getriebe notwendige Leistung, um Arbeiten von Getriebe bei der für das Getriebe gedachten Anwendung zu gewährleisten.

- Notwendige Moment (T): [Nm]

Notwendige Moment für Anwendungen. Für den ausgewählte Getriebe soll das notwendige Moment gleich dem Ausgangsmoment oder kleiner als diesem Moment sein.

- Zulässige Axial- oder Querkräfte:

Fqem, Fqam [N]

Bei den Anwendungen während der Betrieb zulässige axiale oder radiale Eingangs- oder Ausgangsbelastungen.

- Betriebsfaktor (f_s):

Dieser Faktor f_s ist ein Sicherheitsfaktor, damit die Getriebe unter verschiedenen Bedingungen mit genügender Sicherheit arbeitet. $f_s=1$ gilt für gleichförmig Belastung, mit 8 Betriebsstunden pro Tag und bis zum 100 Schaltungen pro Stunde.

Technische Informationen:

- Geräuschpegel:

Geräuschstärken aller Getriebe bleiben unter die zulässigen Werte, die für die Getriebe in der VDI-Richtlinie 2159 festgelegt sind.

- Lackierung und Korrosionsschutz:

Die Getriebe werden mit der Farbe RAL 7031 nach DIN1843 lackiert. Auf Wunsch sind Sonderlackierungen möglich. Alle Getriebe können auf Wunsch auch in korrosionsgeschützter Ausführung für aggressive Umgebungen geliefert werden.

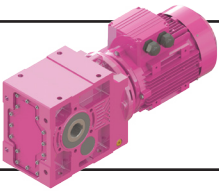

Genel Bilgiler

General Information

Einführung



- Yağlama:

K Serisi redüktörler yağlama tablolarında verilen yağlar ile doldurulmaktadır. Yağ detayları için yağlama bölümüne bakınız.

- Aksesuarlar:

K Serisi redüktörlerde aşağıdaki aksesuarlar kullanılabilir

- IEC B5 Motor bağlantı flanşları
- Çıkış Bağlantı Flanşları
- Sıkma bileziği
- Geri dönüş kilidi
- Özel keçe çözümleri,
- Şeffaf yağ seviye göstergesi
- Tork kolu
- Elektromanyetik frenler

Diğer özel aksesuarlar için lütfen, YILMAZ REDÜKTÖR ile temasa geçiniz.

- Yüzey Koruması

Redüktörlerimiz aksi belirtilmedikçe boyalı olarak sevk edilmektedir. DIN EN ISO 12944-2 korozyon standardında belirtilen sınıflardan aşağıdaki tabloda belirtilen 4 kategori için yüzey koruması sağlanmaktadır. Standart boya sınıfımız C2 korozyon kategorisini karşılamaktadır. Farklı bir koruma sınıfı istenirse sipariş aşamasında belirtilmelidir.

Mil, flanş bağlantı yüzeyi gibi boyanmayan yüzeylere paslanmaya karşı koruma sağlamak için korozyon önleyici yağ sürülmektedir.

- Lubrication:

K series of gearboxes filled with oils which are indicated on lubrication tables. For lubrication details please refer to the lubrication section.

- Accessories:

The following accessories can be applied to K series gearboxes.

- IEC B5 Motor connection flange
- Output flanges
- Shrink Discs
- Backstops
- Special sealing solutions,
- Transparent oil level indicator,
- Torque arm,
- Electromagnetic brakes.

For other accessories please contact, YILMAZ REDÜKTÖR.

- Surface Protection

Our products are all painted unless otherwise stated. 4 corrosion categories which are mentioned below can be offered according to corrosion categories of DIN EN ISO 12944-2 standard. Our standard paint meets C2 corrosion category. If different category is requested, please inform before order.

Unpainted parts such as shaft, flange connection surface are coated with anti-corrosion paint before shipment against corrosion.

- Schmierung:

K Serie Getriebe werden mit Ölen entsprechend der Schmierungstabellen, falls nicht anders vereinbart, geliefert. Für weitere Schmierungsangaben siehe Kapitel Schmierung.

- Zubehör:

Folgendes Zubehör kann für Getriebe der K Serie geliefert werden.

- IEC B5 Motor Adapter,
- Abtriebsflansch,
- Schrumpfscheiben,
- Rücklaufsperrn,
- Unterschiedliche Dichtungssysteme,
- Ölstandzeiger,
- Drehmomentstütze,
- Elektromagnetische Bremsen

Für weiteres Zubehör kontaktieren Sie bitte mit, YILMAZ REDÜKTÖR.

- Oberflächenschutz

Getriebe von Yılmaz Redüktör werden lackiert und so geliefert falls nicht anders vereinbart ist. Die 4 untenstehenden Korrosionskategorien können nach Korrosionsschutz-Basisnorm DIN EN ISO 12944-2 angeboten werden. Unsere Standard-Lackierung erfüllt C2-Korrosionskategorie. Wenn Sie eine andere Kategorie erwünschen, informieren Sie uns bitte darüber vor der Bestellung.

Nicht lackierte Teile (z.B. Welle, Oberfläche des Anschlussflanschs) werden mit einem Schutzmittel vor dem Versand geschmiert, um vor Korrosion und Rost zu schützen.

Korozyon Kategorisi Corrosion Categories Korrosivitätskategorie	Çevre Şartları Ambient Conditions Umgebungsbedingungen	Boya Tipi Paint Type Lackierung	Boya Kalınlıkları Paint Thickness Sollschichtdicke
C2 (Standard)	İç ortam ve muhafazalı dış ortam Nem ve kirlilik oranı düşük çalışma ortamı <i>Indoor installation and outdoor installation with protection roof</i> <i>Environments with low humidity and contamination</i> Innenaufstellung und Außenaufstellung mit Überdachung oder Schutzeinrichtung Atmosphäre mit niedriger Luftfeuchtigkeit und Verunreinigung	Çift Komponent Astar <i>Two-Component Primer Coat</i> Zwei-Komponenten-Grundierung Akrilik Sonkat <i>Acrylic Top Coat</i> Akryl-Decklack	60 µm 40 µm
C3	İç ortam ve atmosfere açık dış ortam Orta seviyede nem ve kirlilik olan çalışma ortamı <i>Indoor installation and outdoor installation subject to weathering</i> <i>Environments with mean humidity and contamination</i> Innenaufstellung und Außenaufstellung im Freien unter Bewitterung Atmosphäre mit mäßiger Luftfeuchtigkeit und Verunreinigung	Epoksi Astar <i>Epoxy Primer Coat</i> Epoxy-Grundierung Akrilik Sonkat <i>Acrylic Top Coat</i> Akryl-Decklack	80 µm 40 µm
C4	İç ortam ve atmosfere açık dış ortam Genelde yüksek nem ve kimyasal madde olan çalışma ortamı <i>Indoor installation and outdoor installation subject to weathering</i> <i>Environments with occasionally high humidity and chemical contamination</i> Innenaufstellung und Außenaufstellung im Freien unter Bewitterung Atmosphäre gelegentlich mit hoher Luftfeuchtigkeit und chemischer Verunreinigung	Epoksi Astar <i>Epoxy Primer Coat</i> Epoxy-Grundierung Akrilik Sonkat <i>Acrylic Top Coat</i> Akryl-Decklack	180 µm 40 µm
C5-I / C5-M	İç ortam ve atmosfere açık dış ortam Sürekli yüksek nem ve kimyasal madde ile temizlik yapılan çalışma ortamı <i>Indoor installation and outdoor installation subject to weathering</i> <i>Environments with permanent high humidity and chemical cleaning contamination</i> Innenaufstellung und Außenaufstellung im Freien unter Bewitterung Atmosphäre mit ständiger hoher Luftfeuchtigkeit und chemischer Verunreinigung (Nassreinigung mit Säuren/Laugen und auch mit chemischen Reinigungsmitteln).	Çinko Üklemeli Epoksi Astar <i>Epoxy Zinc Primer Coat</i> Epoxy-Zink-Grundierung Epoksi Astar Miox <i>Epoxy Miox Primer Coat</i> Epoxy-Miox-Grundierung Akrilik Sonkat <i>Acrylic Top Coat</i> Akryl-Decklack	70 µm 150 µm 40 µm

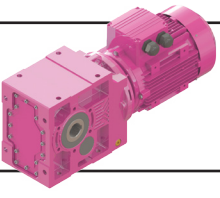

Genel Bilgiler
General Information
Einführung



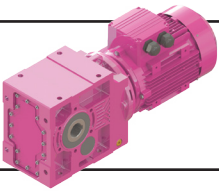

Genel Bilgiler General Information Einführung



Tip Tanımlaması / Unit Designation / Typenbezeichnung

K R 3 7 3 . 02 R - 3 E90S / 4C - L05

Fren / Brake / Bremse

L-220V Fanlı / With Fan / Mit Lüfter	00- 5 Nm	10- 100 Nm
P-24V Fanlı / With Fan / Mit Lüfter	01- 10 Nm	20- 200 Nm
S-220 V Fansız / Without Fan / Ohne Lüfter	02- 25 Nm	30- 300 Nm
Z-24 V Fansız / Without Fan / Ohne Lüfter	04- 40 Nm	40- 400 Nm
	05- 50 Nm	50- 500 Nm

Kutup sayısı / Number of Poles / Anzahl der Polen

Motor Büyüklüğü / Motor Size / Motorbaugröße

KV Tipleri için / For KV types / Für Typen KV

E90 S / 4

Kutup Sayısı / Pole Number /
Anzahl der polen

Gövde uzunluğu / Frame Length /
Gehäuselänge

Motor büyüklüğü / Motor size /
Motorbaugröße

Motor tipi / Motor type /
Motortyp

Motor verim sınıfı / Motor efficiency class / Motor-Effizienzklasse

KN tipleri için / For KN Types / Für Typen KN

A06 : 63 B5 A10 : 100 B5 A20 : 200 B5

B06 : 63 B14 B10 : 100 B14 A22 : 225 B5

A07 : 71 B5 A11 : 112 B5 A25 : 250 B5

A08 : 80 B5 A13 : 132 B5 A31 : 315 B5

B08 : 80 B14 B13 : 132 B14

A09 : 90 B5 A16 : 160 B5

B09 : 90 B14 A18 : 180 B5

Çıkış Mil - Flanş Yönü / Output Shaft - Flange Position / Ausgangswelle - Seite von dem Flansch

Çıkış Özelliği / Output Specification / Eigenschaft der Ausgang

00 :Standart delik milli / Hollow output shaft / Standarte Ausführung mit Hohlwelle

01 :Mil Çıkışlı / Solid output shaft / Vollwelle

02 :Flanşlı ve mil çıkışlı / Solid output shaft and with Flange / Mit Flansch und Abtriebsvollwelle

03 :Flanşlı ve delik milli çıkışlı / Flanged and hollow output shaft / Mit Flansch und Hohlaustragschwelle

04 :Çift çıkış milli / With double output shaft / Mit doppelter Abtriebswelle

05 :Çift flanşlı ve çift çıkış milli / Double flanged and double output shaft / Mit doppeltem Flansch und doppelter Abtriebswelle

08 :Çift flanşlı delik milli /Double flanged and hollow output shaft / Mit doppeltem Flansch und Aufsteckwelle

0S :Sıkma Bilezikli / Shrink disk output / Schrumpfscheibe

0E :Ekstruder Çıkışlı / Extruder output / Extruder-Ausgang

Kademe Sayısı / Stage / Anzahl der Stufen

2 kademe / 2 Stages / 2 Stufig

3 kademe / 3 Stages / 3 Stufig

4 kademe / 4 Stages / 4 Stufig

5 kademe / 5 Stages / 5 Stufig

6 kademe / 6 Stages / 6 Stufig

Revizyon Numarası / Revision Number / Änderungsnummer

Gövde Büyüklük / Housing Size / Größe von Gehäuse

0...9

Giriş Tipi / Input Type / Eingangstyp

R :Motorlu / With Motor / Mit Motor

N :Motorsuz ve IEC B5/B14 Flanş girişli / IEC B5 / B14 Flanged without Motor / Ohne Motor und mit IEC B5/B14 Eingangsflanşch

V :Motorlu ve IEC B5/B14 Flanş girişli / IEC B5 / B14 Flanged with Motor / Mit Motor und IEC B5/B14 Eingangsflanşch

T :Motorsuz / Without Motor / Eingang mit Vollwelle ohne Motor

Redüktör Tipi / Gearbox Type / Getriebe

K Serisi / K Serie / K Serie

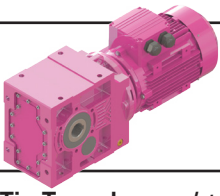

Genel Bilgiler

General Information

Einführung



Tip Tanımlaması / Unit Designation / Typenbezeichnung

KR..00..	Konik-Helisel tip redüktörler, motor bağlantılı, delik milli çıkış / Bevel-Helical type geared motors , Direct coupled motor, Hollow shaft output / Kegelradgetriebe, Verbunden mit Motor, Ausgang mit Hohlwelle.
KR..01..	Konik-Helisel tip redüktörler, motor bağlantılı, milli çıkış / Bevel-Helical type geared motors, Direct motor coupled, solid output shaft / Kegelradgetriebe, Verbunden mit Motor, Ausgang mit Vollwelle.
KR..02..	Konik-Helisel tip redüktörler, motor bağlantılı, mil ve flanş çıkışlı / Bevel-Helical type geared motors, Direct motor coupled, Solid output shaft and output flange / Kegelradgetriebe, Verbunden mit Motor, Ausgang mit Vollwelle und Flansch.
KR..03..	Konik-Helisel tip redüktörler, motor bağlantılı delik milli ve flanş çıkışlı / Bevel-Helical type geared motors, Direct motor coupled, Hollow output shaft and output flange / Kegelradgetriebe, Verbunden mit Motor, Ausgang mit Hohlwelle und Flansch.
KR..04..	Konik-Helisel tip redüktörler, motor bağlantılı, çift çıkış milli / Bevel-Helical type gerboxes, Direct motor coupled, double output shaft, / Kegelradgetriebe, Verbunden mit Motor, mit doppelter Ausgangswelle
KR..05..	Konik-Helisel tip redüktörler, motor bağlantılı çift milli ve çift flanş çıkışlı / Bevel-Helical type geared motors, Direct motor coupled, double hollow output shaft and double flange output. / Kegelradgetriebe, Verbunden mit Motor, Ausgang mit Hohlwelle und Flansch.
KR..08..	Konik-Helisel tip redüktörler, motor bağlantılı delik milli ve çift flanş çıkışlı / Bevel-Helical type geared motors, Direct motor coupled, double hollow output shaft and double flange output. / Kegelradgetriebe, Verbunden mit Motor, Ausgang mit Hohlwelle und Flansch.
KR..0S..	Konik-Helisel tip redüktörler, motor bağlantılı, sıkma bilezik çıkışlı / Bevel-Helical type geared motors Direct motor coupled , Shrink disk output / Kegelradgetriebe, Verbunden mit Motor, Ausgang mit Schrumpfscheibe
KR..0E..	Konik-Helisel tip motorlu redüktörler, motor bağlantılı, ekstruder çıkışlı / Bevel-Helical type geared motors Direct motor coupled , extruder output / Kegelradgetriebe, Verbunden mit Motor, Ausgang mit Extruder
KN..00..	Konik-Helisel tip redüktörler, IEC B5/B14 flanşlı motorsuz , delik milli çıkış / Bevel-Helical type gearboxes, IEC B5/B14 flanged input without motor, hollow output shaft / Kegelradgetriebe, ohne Motor mit IEC B5/B14 Flansch , Ausgang mit Hohlwelle.
KN..01..	Konik-Helisel tip redüktörler, IEC B5/B14 flanşlı motorsuz , mil çıkışlı / Bevel-Helical type gearboxes, IEC B5/B14 flanged input without motor, Solid output shaft / Kegelradgetriebe, ohne Motor mit IEC B5/B14 Flansch, Ausgang mit Vollwelle.
KN..02..	Konik-Helisel tip redüktörler, IEC B5/B14 flanşlı motorsuz, mil ve flanş çıkışlı / Bevel-Helical type gearboxes, IEC B5/B14 flanged input without motor, Solid output shaft and output flange / Kegelradgetriebe, ohne Motor mit IEC B5/B14 Flansch, Ausgang mit Vollwelle und Flansch.
KN..03..	Konik-Helisel redüktörler, IEC B5/B14 flanşlı motorsuz, delik milli ve flanş çıkışlı / Bevel-Helical type gearboxes, IEC B5/B14 flanged input without motor, Hollow output shaft and output flange / Kegelradgetriebe, ohne Motor mit IEC B5/B14, Ausgang mit Hohlwelle und Flansch.
KN..04..	Konik-Helisel tip redüktörler, IEC B5/B14 flanşlı motorsuz, çift çıkış milli / Bevel-Helical type gerboxes, IEC B5/B14 flanged without motor, double output shaft, / Kegelradgetriebe, ohne Motor mit IEC B5/B14, mit doppelter Ausgangswelle
KN..05..	Konik-Helisel tip redüktörler, IEC B5/B14 flanşlı motorsuz ,çift milli ve çift flanş çıkışlı / Bevel-Helical type geared motors, IEC B5/B14 flanged input without motor, double hollow output shaft and flange output. / Kegelradgetriebemotor, Verbunden mit Motor, Ausgang mit Hohlwelle und Flansch.
KN..08..	Konik-Helisel tip redüktörler, IEC B5/B14 flanşlı motorsuz ,delik milli ve çift flanş çıkışlı / Bevel-Helical type geared motors, IEC B5/B14 flanged input without motor ,double hollow output shaft and double flange output. / Kegelradgetriebemotor, Verbunden mit Motor, Ausgang mit Hohlwelle und Flansch.
KN..0S..	Konik-helisel tip helisel redüktörler, IEC B5/B14 flanşlı motorsuz, sıkma bilezik çıkışlı / Bevel-Helical type geared motors IEC B5/B14 flanged without motor, Shrink disk Output / Kegelradgetriebemotor, ohne Motor mit IEC B5/B14, Ausgang mit Schrumpfscheibe
KN..0E..	Konik-helisel tip helisel redüktörler, IEC B5/B14 flanşlı motorsuz, ekstruder çıkışlı / Bevel-Helical type geared motors IEC B5/B14 flanged without motor, extruder output / Kegelradgetriebemotor, ohne Motor mit IEC B5/B14, Ausgang mit Extruder.
KV..00..	Konik-Helisel tip helisel redüktörler, IEC B5/B14 flanşlı, motorlu, delik milli çıkış / Bevel-helical type gearboxes, IEC B5/B14 flanged input with coupled motor, hollow output shaft / Kegelradgetriebe, Verbunden mit IEC B5/B14 Motorverbindung, Ausgang mit Hohlwelle.
KV..01..	Konik-Helisel tip helisel redüktörler, IEC B5/B14 flanşlı, motorlu, mil çıkışlı / Bevel-helical type gearboxes, IEC B5/B14 flanged input with coupled motor, solid output shaft / Kegelradgetriebe, Verbunden mit IEC B5/B14 Motorverbindung, Ausgang mit Vollwelle.
KV..02..	Konik-Helisel tip helisel redüktörler, IEC B5/B14 flanşlı, motorlu, mil ve flanş çıkışlı / Bevel-helical type gearboxes, IEC B5/B14 flanged input with coupled motor, with solid output shaft and output flange / Kegelradgetriebe, Verbunden mit IEC B5/B14 Motorverbindung, Ausgang mit Vollwelle und Flansch.
KV..03..	Konik-Helisel tip helisel redüktörler, IEC B5/B14 flanşlı, motorlu, delik milli ve flanş çıkışlı / Bevel-helical type gearboxes, IEC B5/B14 flanged input with coupled motor, Hollow output shaft and output flange / Kegelradgetriebe, Verbunden mit IEC B5/B14 Motorverbindung, Ausgang mit Hohlwelle und Flansch.
KV..04..	Konik-Helisel tip redüktörler, motor bağlantılı, çift çıkış milli / Bevel-Helical type gerboxes, IEC B5/B14 flanged input with coupled motor, double output shaft, / Kegelradgetriebe, Verbunden mit IEC B5/B14 Motorverbindung, mit doppelter Ausgangswelle
KV..05..	Konik-Helisel tip helisel redüktörler, IEC B5/B14 flanşlı, motorlu, çift milli ve çift flanş çıkışlı / Bevel-helical type gearboxes, IEC B5/B14 flanged input with coupled motor, double output shaft and double output flange / Kegelradgetriebe, Verbunden mit IEC B5/B14 Motorverbindung, Ausgang mit Hohlwelle und Flansch.
KV..08..	Konik-Helisel tip redüktörler, IEC B5/B14 flanşlı, motorlu, delik milli ve çift flanş çıkışlı / Bevel-Helical type geared motors, IEC B5/B14 flanged input with direct coupled motor, double hollow output shaft and double flange output. / Kegelradgetriebemotor, Verbunden mit Motor, Ausgang mit Hohlwelle und Flansch.
KV..0S..	Konik-Helisel tip redüktörler, IEC B5/B14 flanşlı motorlu, sıkma bilezik çıkışlı / Bevel-Helical geared motors IEC B5/B14 flanged with direct coupled motor, Shrink disk output / Kegelradgetriebemotor, Verbunden mit IEC B5/B14 Motorverbindung, Ausgang mit Schrumpfscheibe
KV..0E..	Konik-Helisel tip helisel redüktörler, IEC B5/B14 flanşlı motorlu, ekstruder çıkışlı / Bevel-Helical geared motors IEC B5/B14 flanged with direct coupled motor, Extruder Output / Kegelradgetriebemotor, Verbunden mit IEC B5/B14 Motorverbindung, Ausgang mit ekstruder.
KT..00..	Konik-Helisel tip helisel redüktörler, motorsuz ve mil girişli, delik milli çıkış / Bevel-Helical geared unit, Solid shaft input without motor, Hollow output shaft / Kegelradgetriebe, Eingang mit Vollwelle ohne Motor, Ausgang mit Hohlwelle.
KT..01..	Konik-Helisel tip helisel redüktörler, motorsuz ve mil girişli, mil çıkışlı / Bevel-Helical geared units, Solid shaft input without motor, Solid output shaft / Kegelradgetriebe, Eingang mit Vollwelle ohne Motor, Ausgang mit Vollwelle.
KT..02..	Konik-Helisel tip helisel redüktörler, motorsuz ve mil girişli, mil ve flanş çıkışlı / Bevel-Helical gear units, Solid shaft input without motor, Solid output shaft and flange output / Kegelradgetriebe, Eingang mit Vollwelle ohne Motor, Ausgang mit Vollwelle und Flansch.
KT..03..	Konik-Helisel tip helisel redüktörler, motorsuz ve mil girişli, delik milli ve flanş çıkışlı / Bevel-Helical gear units, solid shaft input without motor, Hollow output shaft and output flange / Kegelradgetriebe, Eingang mit Vollwelle ohne Motor, Ausgang mit Hohlwelle und Flansch.
KT..04..	Konik-Helisel tip redüktörler, motor bağlantılı, çift çıkış milli / Bevel-Helical type gerboxes, solid input shaft, double output shaft, / Kegelradgetriebe, Eingang mit Vollwelle, mit doppelter Ausgangswelle
KT..05..	Konik-Helisel tip helisel redüktörler, IEC B5/B14 flanşlı, motorsuz, çift milli ve çift flanş çıkışlı / Bevel-helical type gearboxes, IEC B5/B14 flanged input without motor, double output shaft and double output flange / Kegelradgetriebe, Verbunden mit IEC B5/B14 Motorverbindung, Ausgang mit Hohlwelle und Flansch.
KT..08..	Konik-Helisel tip redüktörler, IEC B5/B14 flanşlı, motorlu, delik milli ve çift flanş çıkışlı / Bevel-Helical type geared motors, IEC B5/B14 flanged input with without motor, double hollow output shaft and double flange output. / Kegelradgetriebemotor, Verbunden mit Motor, Ausgang mit Hohlwelle und Flansch.
KT..0S..	Konik-Helisel tip helisel redüktörler, motorsuz, sıkma bilezik çıkışlı / Bevel-Helical gear motors, Solid shaft input without motor, Shrink Disk Output / Kegelradgetriebe, ohne Motor, Ausgang mit Schrumpfscheibe
KT..0E..	Konik-Helisel tip helisel redüktörler, motorsuz, ekstruder çıkışlı / Bevel-Helical gear motors, Solid shaft input without motor, Extruder Output / Kegelradgetriebe, ohne Motor, Ausgang mit Extruder.

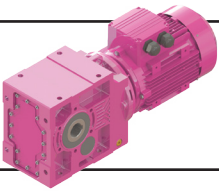

Genel Bilgiler

General Information

Einführung

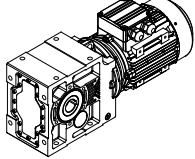
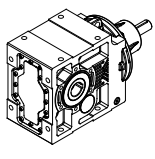
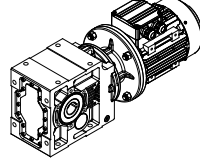
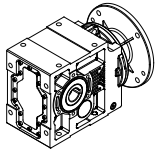
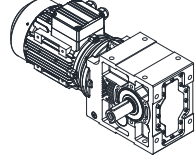
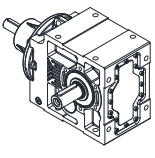
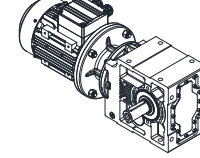
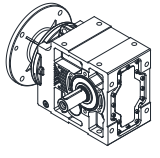
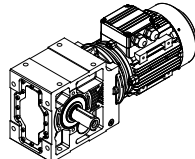
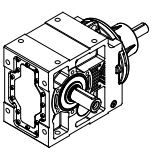
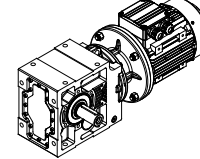
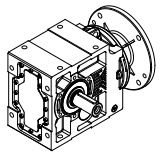
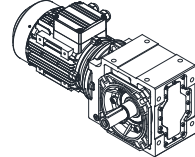
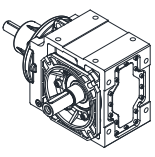
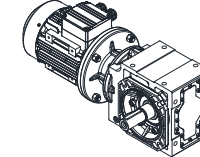
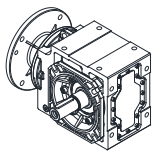
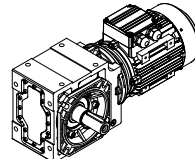
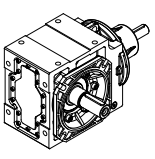
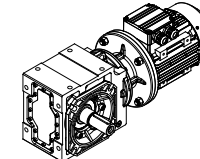
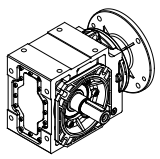
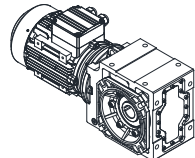
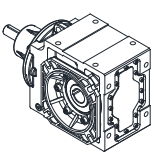
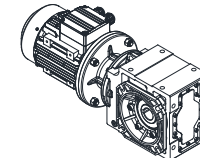
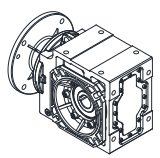
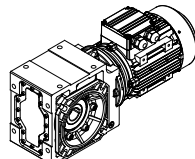
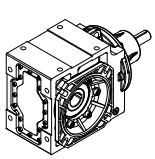
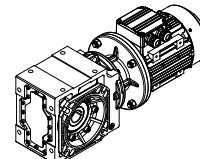
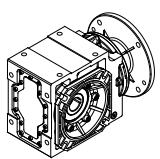
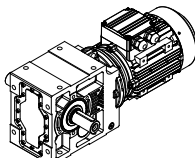
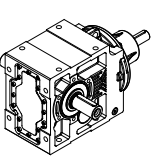
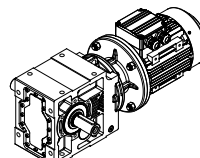
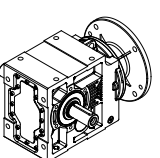
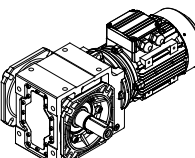
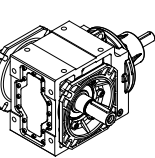
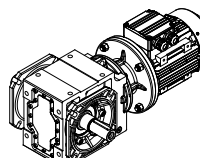
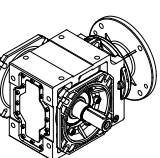
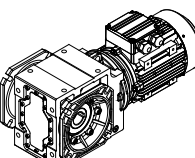
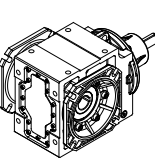
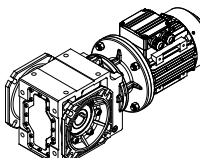
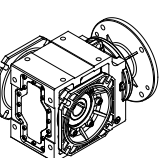

Tip Tanımlaması / Unit Designation / Typenbezeichnungen

KR..00 	KT..00 	KV..00 	KN..00 
KR..01R 	KT..01R 	KV..01R 	KN..01R 
KR..01L 	KT..01L 	KV..01L 	KN..01L 
KR..02R 	KT..02R 	KV..02R 	KN..02R 
KR..02L 	KT..02L 	KV..02L 	KN..02L 
KR..03R 	KT..03R 	KV..03R 	KN..03R 
KR..03L 	KT..03L 	KV..03L 	KN..03L 
KR..04 	KT..04 	KV..04 	KN..04 
KR..05 	KT..05 	KV..05 	KN..05 
KR..08 	KT..08 	KV..08 	KN..08 

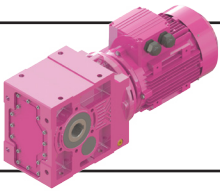

Genel Bilgiler

General Information

Einführung



KR..0SR 	KT..0SR 	KV..0SR 	KN..0SR
KR..0SL 	KT..0SL 	KV..0SL 	KN..0SL
KR..0ER 	KT..0ER 	KV..0ER 	KN..0ER
KR..0EL 	KT..0EL 	KV..0EL 	KN..0EL

Örnek Tip Tanımlamaları

KR273.00-3E90S/4-L05

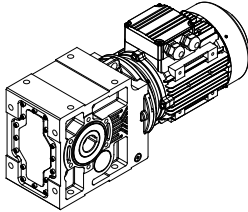

K.....: K serisi redüktör
R.....: Motor bağlantılı
2.....: Gövde büyüklük
7.....: Revizyon numarası
3.....: Kademe sayısı
00.....: Delik mil çıkışlı
3.....: Verim Sınıfı IE3
E.....: Motor tipi
90S/4.....: Motor büyüklüğü
L05.....: Fren Tipi

KT373.01L

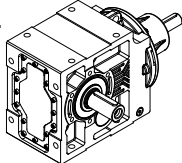

K.....: K serisi redüktör
T.....: Motorsuz giriş mili
3.....: Gövde büyüklüğü
7.....: Revizyon numarası
3.....: Kademe sayısı
01.....: Mil çıkışlı
L.....: Sol mil çıkışlı
R.....: Sağ mil çıkışlı

Sample Designations

KR273.00-3E90S/4-L05

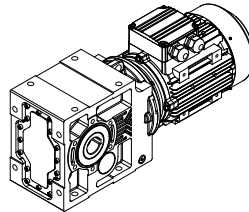

K.....: K serie of gearbox
R.....: Direct motor coupled
2.....: Gear unit size
7.....: Revision number
3.....: Stage number
00.....: Hollow shaft output
3.....: Efficiency class IE3
E.....: Motor type
90S/4.....: Motor frame size
L05.....: Brake type

KT373.01L

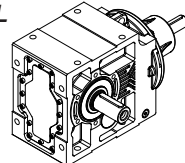

K.....: K series of gearbox
T.....: Solid input shaft
3.....: Gear unit size
7.....: Revision number
3.....: Stage number
01.....: Solid output shaft
L.....: Left side output shaft
R.....: Right side output shaft

Typenbezeichnungsbeispiele

KR273.00-3E90S/4-L05

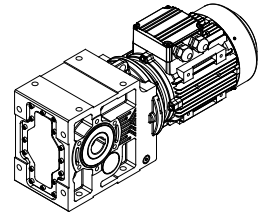

K.....: K Serie Getriebe
R.....: Motorverbindung
2.....: Größe von Gehäuse
7.....: Änderungsnummer
3.....: Stufenanzahl (2 stufig)
00.....: Hohlansgangswelle
3.....: Effizienzklasse IE3
E.....: Motortyp
90S/4.....: Motorbaugröße
L05.....: Bremse

KT373.01L

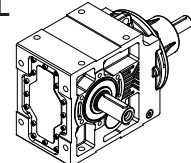

K.....: K Serie Getriebe
T.....: Vollwelleneingang ohne Motor
3.....: Größe der Gehäuse
7.....: Änderungsnummer
3.....: Stufenanzahl
01.....: Vollwelle
L.....: Ausgangswelle-links
R.....: Ausgangswelle-rechts

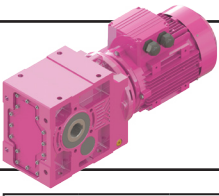

Genel Bilgiler

General Information

Einführung



Motor Büyüklüğüne Göre Geometrik Mümkün Çevrim Oranları

Geometrically Possible Combinations of Ratios According to Motor Size

Geometrisch mögliche Kombinationen von Übersetzungen nach Motorbaugröße

Motor Büyüklüğü / Motor Size / Motorbaugröße

Tip Type Typ	Kademe Stages Stufen	63	71	80	90	100	112	132
KR002..	2	7,46-19,88	7,46-19,88	7,46-19,88	7,46-13,26	-	-	-
KR003..	3	23,79-120,91	23,79-120,91	23,79-29,95 45,41-57,16	23,79-29,95 45,41-57,15	-	-	-
KR102..	2	6,28-25,50	6,28-25,50	6,28-25,50	6,28-17,30	-	-	-
KR103..	3	20,03-129,27	20,03-129,27	20,03-76,13 116,34-129,27	20,03-76,13	-	-	-
KR202..	2	6,38-23,79	6,38-23,79	6,38-23,79	6,38-23,79	6,38-15,26	6,38-10,57	-
KR203..	3	26,31-138,53	26,31-138,53	26,31-119,62	26,31-119,62	26,31-104,49	26,31-72,37	-
KR273..	3	6,94-113,65	6,94-113,65	6,94-113,65	6,94-83,48	6,94-72,92	6,94-50,51	6,94-9,92; 13,34-19,08; 25,55-36,55
KR275..	5	54,40-719,79	54,40-719,79	54,40-719,79	54,40-719,79	-	-	-
KR276..	6	735,5-1759,48	735,5-1759,48	735,5-1759,48	735,5-1759,48	-	-	-
KR283..	3	6,70-10,16; 14,12-21,42; 32,35-143,00	6,70-10,16; 14,12-21,42; 32,35-143,00	6,70-10,16; 14,12-21,42; 32,35-106,33	6,70-10,16; 14,12-21,42; 32,35-106,33	4,92-93,50	4,92-66,00	4,92-49,08
KR284..	4	122,22-353,22	122,22-353,22	122,22-353,22	122,22-353,22	-	-	-
KR285..	5	300,42-1052,64	300,42-1052,64	300,42-1052,64	300,42-1052,64	-	-	-
KR286..	6	820,35-3333,36	820,35-3333,36	820,35-3333,36	820,35-3333,36	-	-	-
KR373..	3	-	7,73-9,97 14,44-21,90 33,65-148,75	7,73-9,97 14,44-21,90 33,65-148,75	7,73-9,97 14,44-21,90 33,65-110,61	5,68-97,26	5,68-68,65	5,68-51,05
KR374..	4	127,14-367,43	127,14-367,43	127,14-367,43	127,14-367,43	-	-	-
KR375..	5	312,5-1094,97	312,5-1094,97	312,5-1094,97	312,5-1094,97	-	-	-
KR376..	6	853,34-3467,39	853,34-3467,39	853,34-3467,39	853,34-3467,39	-	-	-
KR473..	3	-	-	23,76-30,11 60,63-153,47	23,76-30,11 60,63-153,47	7,48-110,95	6,21-97,79	6,21-76,83
KR474..	4	-	160,79-472,63	160,79-472,63	160,79-472,63	160,75-207,41	160,79-181,88	-
KR475..	5	509,34-1767,9	509,34-1767,9	509,34-1767,9	509,34-1767,9	509,34-1142,99	509,34-844,06	-
KR476..	6	2183,54-5226,85	2183,54-5226,85	2183,54-5226,85	2183,54-5226,85	2183,54-3602,83	2183,54-3379,28	-
KR573..	3	-	-	-	-	20,24-25,78 44,73-125,51	20,24-25,78 38,16-109,86	6,91-97,19
KR574..	4	-	117,96-469,74	117,96-469,74	117,96-469,74	117,96-328,56	117,96-158,64 246,42	117,96
KR575..	5	507,09-2236,28	507,09-2236,28	507,09-2236,28	507,09-2236,28	-	-	-
KR576..	6	2328,84-6611,61	2328,84-6611,61	2328,84-6611,61	2328,84-6611,61	-	-	-
KR673..	3	-	-	-	-	80,38-128,24	80,38-128,24	8,31-14,49 18,74-128,24
KR674..	4	-	-	123,38-363,81	123,38-363,81	123,38-363,81	123,38-321,51	123,38
KR675..	5	-	531,08-1875,03	531,08-1875,03	531,08-1875,03	423,90-1875,03	423,90-809,27	423,90-724,08
KR676..	6	-	1884,33-12680,66	1884,33-12680,66	1884,33-12680,66	1884,33-5445,72	1884,33-3844,04	1884,33-2858,39
KR773..	3	-	-	-	-	-	-	11,44-12,89 23,52-26,52 45,36-111,63
KR774..	4	-	-	127,11-396,00	127,11-396,00	127,11-396,00	127,11-396,00	127,11-311,14
KR775..	5	-	547,17-2066,04	547,17-2066,04	547,17-2066,04	436,74-2066,04	436,74-833,78	436,74-655,11
KR776..	6	-	1941,39-15618,73	1941,39-15618,73	1941,39-15618,73	1941,39-5610,63	1941,39-3960,44	1941,39-2944,95
KR873..	3	-	-	-	-	-	-	49,75-115,87
KR874..	4	-	-	-	-	86,63-438,70	86,63-383,99	86,63-339,7
KR875..	5	-	463,83-1891,08	463,83-1891,08	463,83-1891,08	463,83-1891,08	463,83-1671,18	463,83-1313,07
KR876..	6	-	2074,42-12789,19	2074,42-12789,19	2074,42-12789,19	2074,42-11245,67	2074,42-7938,12	2074,42-5902,70
KR973..	3	-	-	-	-	-	-	-
KR974..	4	-	-	-	-	134,57-398,92	134,57-398,92	134,57-398,92
KR975..	5	-	-	715,34-1585,92	715,34-1585,92	460,51-1585,92	460,51-1585,92	361,44-1585,92
KR976..	6	-	-	1985,89-15680,79	1985,89-15680,79	1985,89-8652,97	1985,89-6741,12	1985,89-4189,63

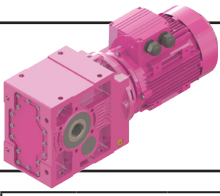

Genel Bilgiler

General Information

Einführung



Motor Büyüklüğüne Göre Geometrik Mümkün Çevrim Oranları

Geometrically Possible Combinations of Ratios According to Motor Size
Geometrisch mögliche Kombinationen von Übersetzungen nach Motorbaugröße

Motor Büyüklüğü / Motor Size / Motorbaugröße

Tip Type Typ	Kademe Stages Stufen	160	180	200	225	250	280	315
KR002..	2	-	-	-	-	-	-	-
KR003..	3	-	-	-	-	-	-	-
KR102..	2	-	-	-	-	-	-	-
KR103..	3	-	-	-	-	-	-	-
KR202..	2	-	-	-	-	-	-	-
KR203..	3	-	-	-	-	-	-	-
KR273..	3	-	-	-	-	-	-	-
KR275..	5	-	-	-	-	-	-	-
KR276..	6	-	-	-	-	-	-	-
KR283..	3	4,92-5,74; 10,37-12,10; 23,76-27,74	4,92-5,74; 10,37-12,10; 23,76-27,74	-	-	-	-	-
KR284..	4	-	-	-	-	-	-	-
KR285..	5	-	-	-	-	-	-	-
KR286..	6	-	-	-	-	-	-	-
KR373..	3	-	-	-	-	-	-	-
KR374..	4	-	-	-	-	-	-	-
KR375..	5	-	-	-	-	-	-	-
KR376..	6	-	-	-	-	-	-	-
KR473..	3	6,21-23,19 ; 25,15 39,11-59,19 ; 64,17	6,21-20,07 39,11-51,22	-	-	-	-	-
KR474..	4	-	-	-	-	-	-	-
KR475..	5	-	-	-	-	-	-	-
KR476..	6	-	-	-	-	-	-	-
KR573..	3	6,91-82,14	6,91-67,37	6,91-18,80 30,25-35,34	-	-	-	-
KR574..	4	-	-	-	-	-	-	-
KR575..	5	-	-	-	-	-	-	-
KR576..	6	-	-	-	-	-	-	-
KR673..	3	8,31-100,90	8,31-90,21	8,31-68,47	8,31-9,45 16,54-21,32 39,26-44,65	-	-	-
KR674..	4	-	-	-	-	-	-	-
KR675..	5	423,9-489,82	423,9	-	-	-	-	-
KR676..	6	-	-	-	-	-	-	-
KR773..	3	7,41-111,63	7,41-99,00	7,41-76,59	7,41-51,13	7,41-51,13	-	-
KR774..	4	-	-	-	-	-	-	-
KR775..	5	-	-	-	-	-	-	-
KR776..	6	-	-	-	-	-	-	-
KR873..	3	11,05-13,93 19,26-24,28 34,28-115,87	11,05-13,93 19,26-24,28 34,28-103,24	9,63-81,06	9,63-55,53	9,63-55,53	9,63-43,22	-
KR874..	4	86,63-235,47	86,63-235,47	-	-	-	-	-
KR875..	5	-	-	-	-	-	-	-
KR876..	6	-	-	-	-	-	-	-
KR973..	3	14,65-18,73 24,73-31,63 42,86-146,20	14,65-18,73 24,73-31,63 42,86-130,38	11,69-103,87	11,69-71,60	11,69-71,60	11,69-54,80	11,69-54,80
KR974..	4	134,57-181,51	134,57-151,03	-	-	-	-	-
KR975..	5	361,44-715,34	361,44-586,70	-	-	-	-	-
KR976..	6	2348,01	-	-	-	-	-	-

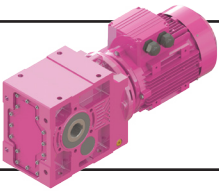

Genel Bilgiler

General Information

Einführung



Servis Faktörü

Servis faktörü (fs) redüktörün çalıştığı şartlar ile uyumlu olması için gerekli olan emniyet katsayısıdır. "fs =1" Düzgün ve sakin yüklerde, günlük sekiz saat ve saatte yüz start çalışmayı karşılar.

Aşağıdaki etkenlere bağlıdır:

- Günlük çalışma süresi
- Yük sınıfı
- Bir saatteki start sayısı
- Redüktör tahrik tipi
- Diğer gözlemler

Bu etkenleri göz önüne aldığımızda, gerekli servis faktörünü belirlemek için:

1. Makinanın günlük çalışma süresini tespit ediniz.
2. Makinanın ne türde yükler verdiğini tespit ediniz (Sayfa 17-18).

- U - Düzgün ve sabit yükler
- M - Orta darbeli yükler
- H - Ağır darbeli yükler

Yük sınıfının daha teknik seçimi için rotora indirgenmiş toplam atalet momenti formülünden faydalanabilirsiniz (Sayfa 18).

3. Saatteki start sayısını tespit ediniz.
4. İlk üç maddeye bağlı servis faktörünü aşağıdaki tablodan seçiniz.

5. fs Redüktörümüzün tahrik tipine bağlı olarak "k" katsayısı ile çarpılarak artırılır.

- k=1 :Elektrik motoru veya hidromotor
k=1.25 :İçten yanmalı çok silindirli motor
k=1.5 :İçten yanmalı tek silindirli motor

Service Factor

Service Factor (fs) is a safety coefficient, which takes into account the different running conditions of the driven machine. "fs=1" is used for uniform loads 8 hours working per day and up to 100 starts per hour.

Service factor depends on:

- Running time
- Nature of load
- Frequency of starting
- Driver type
- Other considerations

For the right selection of the needed service factor for your machine;

1. Determine the running time of driven machine.
2. Select the nature of load of driven machine (Page 17-18).

- U - Uniform loads
- M - Moderate loads
- H - Heavy shock loads

For a better selection, the nature of load can be calculated from the formulas given (page 18).

3. Determine frequency of starting.
4. After determining the above mentioned factors, the service factor can be easily selected from the table given below.
5. The selected service factor multiplied with the factor "k" according to the driver type;

- k=1 :Electric motor or Hydrolicmotor
k=1.25 :Multicylinder internal combustion engine
k=1.5 :Single cylinder internal combustion engine

Betriebsfaktor

Der Betriebsfaktor (fs) ist ein Sicherheitsfaktor für die Getriebe, damit sie unter den Betriebsbedingungen sicher arbeiten. "fs =1" steht für gleichförmige Belastung, 8 Stunden pro Tag und bis zu 100 Schaltungen pro Stunde.

Betriebsfaktor ist abhängig von:

- Betriebsdauer
- Belastungsart
- Schalthäufigkeit
- Antriebsart
- Andere Faktoren

Um die richtigen Betriebsfaktor festzulegen;

1. Betriebsdauer der angetriebenen Maschine bestimmen.
2. Belastungsart der angetriebenen Maschine auswählen.

- U - Gleichförmige Belastung
- M - Ungleichförmige Belastung
- H - Stark Ungleichförmige Belastung

Um eine bessere Auswahl zu treffen, können die Belastungsarten mit den angegebenen Formeln (Seite 18) errechnet werden.

3. Schalthäufigkeit bestimmen.
4. Nach Bestimmen der oben angegebenen Werte, können die Betriebsfaktoren von der unten stehenden Tabelle entnommen werden.
5. Der ausgewählte Betriebsfaktor muß mit dem Faktor "k" abhängig von der Antriebsart multipliziert werden

- k=1 :Elektromotor oder Hydraulikmotor
k=1.25 :Vielzylindermotor
k=1.5 :Einzyldermotor

Günlük Çalışma Süresi
Operating Time hour / Day
Laufzeit Std. / Tag

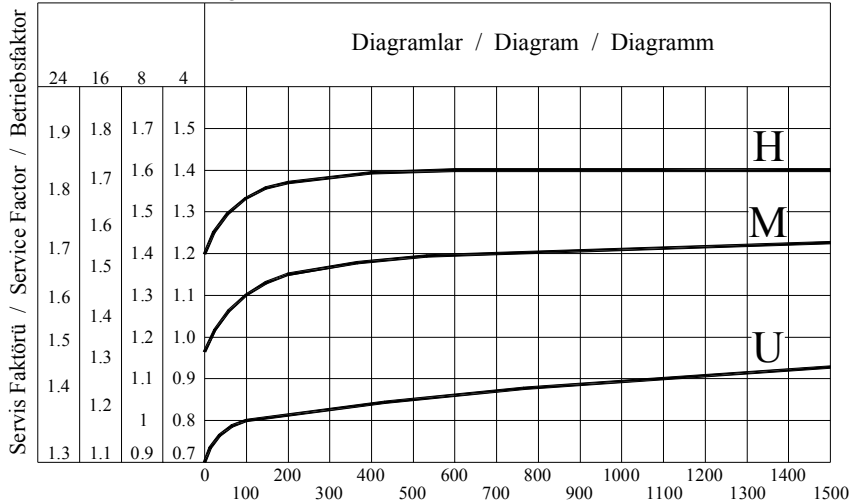

Start sayısı / Saat
Cycle / Hour
Schaltungen / Std.

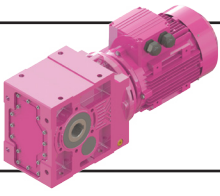

Genel Bilgiler

General Information

Einführung



Yük Sınıflandırması

Krenler:

- U - Kaldırma Dişlileri
- Palanga Dişlileri
- M - Bomlu Vinç Dişlileri
- Yana Döndürme Dişlileri
- H - Yürütme Dişlileri

Pompalar:

- U - Santrifuj Pompalar (ince sıvı)
- M - Santrifuj Pompalar (yarı sıvı)
- H - Basınçlı Pompalar
- Dalgiç Pompalar

Taş ve Kil İşleme Makinaları:

- H - Çekiçli Değirmenler
- Döner Fırınlr
- Dövücü Değirmenler
- Kırıcılar
- Küreli Değirmenler
- Tuğla Presi
- Tüp Değirmenler

Tekstil Makinaları:

- M - Basma ve Boyama Makinaları
- Dokuma Tezgahları
- Hallac Makinaları
- Harman Makinaları
- Taneleme (Debegat)Tekneleri

Yağ Sanayi:

- M - Besleme Pompaları
- Döner Delme Teçizatları

Yiyecek Sanayi:

- M - Kutu Bıçaklar
- Kutu Kaplama
- Mayalama Tekneleri
- H - Kenar Açma

Çamaşır Yıkama Makinaları:

- M - Döner Kurutucular
- Yıkama Makinaları

Hadde Makinaları:

- M - Hız Ayarlı Silindirler
- Sabit Silindirler
- Sarma Makaraları
- Tel Çekme
- H - Çubuk Kesme Makinaları
- Döner Tablalar (büyük)
- Kabuk Sıyırma Makinaları
- Plaka Haddeleme
- Silindir Haddeleme
- Soğuk Haddeleme

Load Classification

Cranes:

- U - Hoist Gears
- Lifting Gears
- M - Defrocking jib Gears
- Slowing Gears
- H - Travelling Gears

Pumps:

- U - Centrifugal Pumps (light liquids)
- M - Centrifugal Pumps (semi liquid)
- H - Pressure Pumps
- Plunger Pumps

Stone and Clay Working Machines:

- H - Hammer Mills
- Rotary Kilns
- Beater Mills
- Breakers
- Ball Mills
- Brick Presses
- Tup Mills

Textile Machines:

- M - Printing and Dyeing Machines
- Looms
- Willow
- Batchers
- Tanning Vats

Oil Industry:

- M - Pipeline Pumps
- Rotary Drilling Equipment

Food Industry:

- M - Cane Knives
- Cane Crushers
- Mach Tubs
- H - Cane Mills

Laundries:

- M - Tumblers
- Washing Machines

Metal Rolling Mills:

- M - Roller Adjustment Drives
- Roller Straightened
- Winding Machines
- Wire Drawing Benches
- H - Billet Shears
- Rotary Tables (heavy)
- Descaling Machines,
- Sheet Mills
- Manipulators
- Cold Rolling Mills

Belastungsart

Krananlagen:

- U - Einziehwerke
- Hubwerke
- M - Schwenkwerke
- Wippwerke
- H - Fahrwerke

Pumpen:

- U - Kreiselpumpen (leichte Flüssigkeit)
- M - Kreiselpumpen (zahe Flüssigkeit)
- H - Prebpumpen
- Plungerpumpen

Stein- und Erdebearbeitende Maschine

- H - Hammermühlen
- Drehofen
- Schlagmühlen
- Brecher
- Kugelmühlen
- Ziegelpressen
- Rohrmühlen

Textilmaschinen:

- M - Drukerei
- Farbereimachinen
- Aufwickler
- Webstuhle
- Gerbfasser
- Reibwolfe

Erdölgewinnung:

- M - Pipeline Pumpen
- Rotative Bohranlagen

Nahrungsmittelmachinen:

- M - Rohrschneiden
- Knetmaschinen
- Maichen
- H - Rohrmühlen

Waschereimaschinen:

- M - Trommeltrockner
- Waschmaschinen

Wälzwerke:

- M - Rollenrichtmaschinen
- Walzenantriebe
- Drahtzuge
- Haspeln
- H - Blechscheren
- Rollgänge (schwer)
- Knüppelscheren
- Schöpfscheren
- Stranggubanlagen
- Kaltwälzwerke

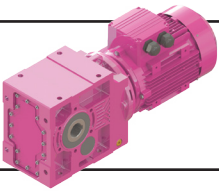

Genel Bilgiler

General Information

Einführung



İnşaat Makinaları:

- M - Beton Mikserleri
- Ağır Yük Asansörleri

Kağıt Makinaları:

- H - Islak Presler
- Kağıt Hamur Makinaları
- Kurutma Silindirleri
- Perdahlama Silindirleri

Kauçuk Makinaları:

- M - Kalenderler
- Mikserler
H - Extruderler
- Hamur Karma
- Silindirler

Kimya Sanayi:

- M - Agidatörler (yarı sıvı)
- Kurutma Merdaneleri
- Mikserler ve Silindirleri

Konveyörler:

- M - Bant Cepeli Konveyörler
- Çelik Bantlı Konveyörler
- Dökme Yüklü Kayışlı Konv.
H - Yük Asansörleri
- Parça Yüklü Kayışlı Konv.

Building Machines:

- M - Concrete Mixers
- Hoist

Paper Machines:

- H - Wet Presses
- Pulpers
- Drying Cylinders
- Glazing Cylinders

Rubber Machinery:

- M - Calenders
- Mixers
H - Extruders
- Pug Mills
- Rolling Mills

Chemical Ind.:

- M - Aggidators (semi-liquid)
- Drying Drums.
- Mixers and Rolling Mills

Conveyors:

- M - Band Pocket Conveyors
- Steel Belt Conveyors
- Belt Conveyors
H - Hoists
- Bulk Belt Conveyors

Baumaschinen:

- M - Betonmischermaschinen
- Bauaufzüge

Papiermaschinen:

- H - Naßpressen
- Gautschen
- Trockenzyylinder
- Glattzyylinder

Kunststoffmaschinen:

- M - Kalender
- Mischer
H - Extruder
- Knetwerke
- Wälzwerke

Chemische Industrie:

- M - Rührwerke (leichte Flüssig.)
- Trockentrommeln
- Mischer und Wälzwerke

Förderanlagen:

- M - Gurtaschenbecherwerke
- Stahlbandförderer
- Gurtbandförderer (Schüttgut)
H - Schrägaufzüge
- Gurtbandförderer (Stückgut)

U	Uniform Yük Uniform Loads Gleichförmige Last	$F_i < 0,25$
M	Orta Darbeli Yük Moderate Loads Ungleichförmige Last	$F_i < 3$
H	Darbeli Yük Heavy Shock Loads Stark Ungleichförmige Last	$F_i < 10$

$$J'_{ext} = \frac{J_{ext}}{i^2}$$

$$F_i = \frac{J'_{ext}}{J_{rotor}}$$

J'_{ext} : **Motor miline indirgenmiş toplam dış atalet momenti**
External moments of inertia reduced to the motor shaft
Externe Massenträgheitsmomente reduziert auf Motorwelle

i : **Tahvil oranı**
Transmission ratio
Übersetzung

J_{rotor} : **Motorun atalet momenti**
Moments of inertia to the motor
Massenträgheitsmoment

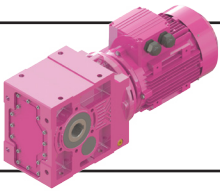

Genel Bilgiler

General Information

Einführung



Redüktör Dönüş Yönleri

K Serisi ürünlerimiz için kullanılan yön tanımlaması aşağıdaki gibidir. Aşağıdaki tanımlama kilitli redüktörler için de geçerlidir.

Direction of Rotation

K Series direction of rotation of Yılmaz products are defined as follows. The definitions are also valid for gear units with backstop.

Getriebedrehrichtungen

Die Drehrichtungen für K Serie Getriebe sind wie folgt definiert. Die Definition ist auch bei Getrieben mit Rücklaufsperre gültig.

	3-5 Kademe / 3-5 Stages / 3-5 Stufig	2-4-6 Kademe / 2-4-6 Stages / 2-4-6 Stufig
Saat Yönünde Clockwise Rechtslauf CW		
Saat Tersi Yönünde Counter Clockwise Linkslauf CCW		

Giriş mili dönüş yönüne göre çıkış mili dönüş yönleri aşağıdaki gibidir.

Output shaft rotation directions according to the input shaft rotation directions are as follows.

Drehrichtungen der Abtriebswelle im Abhängigkeit von der Antriebswellen sind wie folgendes;

3-5 kademe / 3-5 Stages / 3-5 Stufig	2-4-6 Kademe / 2-4-6 Stages / 2-4-6 Stufig

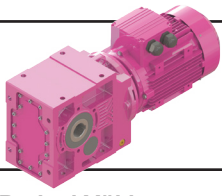

Genel Bilgiler

General Information

Einführung



Radyal Yükler

Çıkış miline gelebilecek radyal yükler yatak ömrüne göre belirlenmiş ve tablo halinde verilmiştir. Bu tabloda verilen F_{qam} güvenilir radyal yükü $f_s=1$ şartı ve yükün mil ortasını yüklediği durum için verilmiştir. Darbeli yüklerin olması durumunda daha önce verilmiş olan servis faktörü tablosundaki değerler dikkate alınmalıdır. Güvenilir aksiyal yük (F_{ama} veya F_{ame}) verilen güvenilir radyal yükün (F_{qam} veya F_{qem}) %25'i kadar alınır. Verilen radyal ve eksenel yükler kuvvetin en kötü açı şartında etki ettiği durum için verilmiştir. Mil ortasına gelen kuvvetin açısına göre daha yüksek radyal yükler mümkündür (Firmamıza danışınız). Bağlantı şekline göre oluşan radyal yük F_q sayfa 21 de verilen formüller yardımı ile hesaplanır. Redüktör seçiminde ;

$$\begin{aligned} F_{qa} &\leq F_{qam} \\ F_{qe} &\leq F_{qem} \end{aligned}$$

şartı göz önünde tutulmalı. Eğer etkiyen radyal kuvvet milin orta noktasında değil ise verilen güvenilir değer in aşağıda verilen formül ile düzeltilmesi gerekir.

$$\begin{aligned} F_{qam}' &= F_{qam} \frac{t}{y+u} \\ F_{qem}' &= F_{qem} \frac{t}{y+u} \end{aligned}$$

"t", "y" Değerleri aşağıda verilmiştir. "u" Değeri görüldüğü gibi kuvvetin uygulama noktasıdır.

Overhung Loads

The permissible overhung loads are calculated by considering working life and is listed on the tables. The given permissible overhung loads F_{qam} are based on $f_s=1$ and are valid for forces which are applied to the midpoint of the shaft. For shock loading applications the service factor given on the table must take into consideration. The permissible axial load (F_{ama} or F_{ame}) is %25 x (F_{qam} or F_{qem}). The listed permissible overhung loads are based on the worst loading direction. Higher overhung loads can be applied for different loading directions (Please ask if requested). The effective overhung load at the gear box shaft F_q will be determined with the given formulas on page 21. In Selection ;

$$\begin{aligned} F_{qa} &\leq F_{qam} \\ F_{qe} &\leq F_{qem} \end{aligned}$$

these formulas must be taken into consideration. If the load is not applied at the midpoint of the shaft; the given permissible load must be corrected with the following formulas.

$$\begin{aligned} F_{qam}' &= F_{qam} \frac{t}{y+u} \\ F_{qem}' &= F_{qem} \frac{t}{y+u} \end{aligned}$$

The values "t", "y" can be taken from the below table. The value "u" is the length of the application point as shown below.

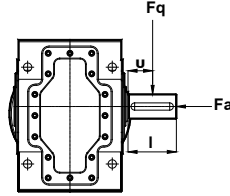

Querkräfte

Die in den nachfolgenden Tabellen angegebenen zulässigen Radialbelastungen F_{qam} gelten bei Kraftangriff auf die Mitte Wellenendes. Den Angaben liegt der Betriebsfaktor $f_s=1$ zu Grunde. Bei stoßartigen Belastungsfällen ist auch hier der entsprechende Betriebsfaktor zu berücksichtigen. Zulässige Axialkräfte F_{ama} oder F_{ame} können ohne weitere Nachrechnung bis zu einer Höhe von ca. 25% der zulässigen Radialbelastung F_{qam} oder F_{qem} aufgenommen werden. Bei der Ermittlung der zulässige Querkräfte sind höhere Werte möglich (Bitte Rückfragen). Die auftretende Querkraft F_q ab der Getriebewelle wird wie in der nachfolgenden Formel bestimmt.

Bei dieser Auswahl;

$$\begin{aligned} F_{qa} &\leq F_{qam} \\ F_{qe} &\leq F_{qem} \end{aligned}$$

müssen die oben angegebenen Bedingungen berücksichtigt werden. Ist der Kraftangriff nicht auf Wellenmitte, so kann die zulässige Querkraft mit Hilfe der unten stehenden Formel auf jede beliebige Stelle umgerechnet werden.

$$\begin{aligned} F_{qam}' &= F_{qam} \frac{t}{y+u} \\ F_{qem}' &= F_{qem} \frac{t}{y+u} \end{aligned}$$

Die Werte "t" und "y" sind in den nachfolgenden Tabellen angegeben. Der Wert "u" ist die Stelle des Kraftangriffs wie auf der nächsten Seite angegeben.

KR...01		Çıkış mili radyal kuvvet hesabı düzeltme katsayıları Overhung Load correcting values on output shaft Querkraft auf Ausgangswelle Korrigierungszahlen										
Tip Type Typ	KR..002 KR..003	KR..102 KR..103	KR..202 KR..203	KR..273	KR..283	KR..373	KR..473	KR..573	KR..673	KR..773	KR..873	KR..973
t	119	134	156	162	183	199	236	273	344	408	485	556
y	99	104	121	132	143	159	186	213	274	323	380	451
l	40	60	70	60	80	80	100	120	140	170	210	210

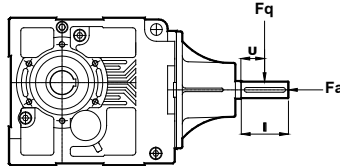

KT...		Giriş mili Radyal kuvvet hesabı düzeltme katsayıları Overhung load correcting values on input shaft Querkraft auf Eingangswelle korrigierungszahlen										
Tip Type Typ	KT..002 KT..003	KT..102 KT..103	KT..202 KT..203	KT..273	KT..283	KT..373	KT..473	KT..573	KT..673	KT..773	KT..873	KT..973
t	78	78	111	111	126	126	137	158	180	207	220	266.5
y	58	58	86	86	96	96	102	113	130	147	165	206.5
l	40	40	50	50	60	60	70	90	100	120	110	120

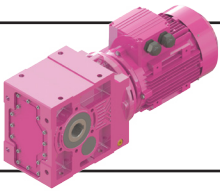

Genel Bilgiler

General Information

Einführung



Radyal Yüklerin Hesabı

Calc. Of Overhung Loads

Berechnung der Querkräfte

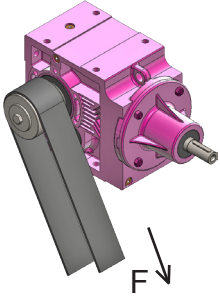

Radyal Yük F_q [N]'nin hesaplanması da, gerekli tahrik momenti M [Nm], kasnak veya dişli çapı D [mm] olmak üzere aşağıdaki formüller kullanılır.

Radial Load F_q [N] is calculated with the following equations where required moment M [Nm] and hoop or gear diameter D [mm] is used.

Der Fall der radialen Belastung F_q [N] kann mit den angegebenen Gleichungen berechnet werden. Antriebsmoment M [Nm] und Zahnrad- oder Riemenscheiben Durchmesser D [mm].

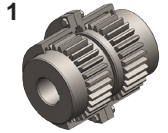

1. Elastik Kaplin

Çalışma sırasında oluşan sapmalar kaplinin güvenlik sınırları içinde ise kuvvetler ihmal edilebilir.

1. Elastic Coupling

If Elastic Coupling is working in its reliable working area, the overhung loads can be neglected.

1. Elastische Kupplung

Wenn die elastische Kupplung in ihrem zulässigen Arbeitsbereich arbeitet, können die radialen Belastungen vernachlässigt werden.

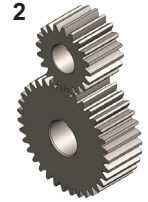

2. Düz Dişli (20° kavrama açısı)

$$F_q = \frac{2100 \times M_2}{D}$$

2. For Spur Gear (Pressure angle 20°)

$$F_q = \frac{2100 \times M_2}{D}$$

2. Stirnradgetriebe (Angriffswinkel 20°)

$$F_q = \frac{2100 \times M_2}{D}$$



3. Küçük Hızlarda Zincir Dişli ($z > 17$)

$$F_q = \frac{2100 \times M_2}{D}$$

3. For Chain Drive With Low Speed ($z > 17$)

$$F_q = \frac{2100 \times M_2}{D}$$

3. Kettenantrieb mit niedriger Geschwindigkeit ($z > 17$)

$$F_q = \frac{2100 \times M_2}{D}$$

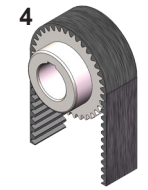

4. Triger Kayış

$$F_q = \frac{2500 \times M_2}{D}$$

4. For Triger Belt

$$F_q = \frac{2500 \times M_2}{D}$$

4. Zahnriemenantrieb

$$F_q = \frac{2500 \times M_2}{D}$$

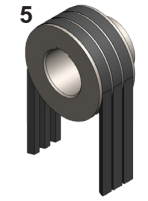

5. V Kayış

$$F_q = \frac{5000 \times M_2}{D}$$

5. For V Belt

$$F_q = \frac{5000 \times M_2}{D}$$

5. Keilriemenantrieb

$$F_q = \frac{5000 \times M_2}{D}$$



6. Gerdirme Makaralı Kayış

$$F_q = \frac{5000 \times M_2}{D}$$

6. Flat Belt With Spanning Pulley

$$F_q = \frac{5000 \times M_2}{D}$$

6. Flachriemenantrieb mit Spannungstrommel

$$F_q = \frac{5000 \times M_2}{D}$$

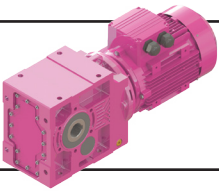

Genel Bilgiler

General Information

Einführung



Ekstruder Tiplerde Müsade Edilebilir Eksenal Yükler

Permissible Axial Loads for Extruder Types
Zulässige Axialkräfte für Extruder Typ Getriebe

KRE273				
n ₂	F _{ama} [kN]			
	Ömür / Lifetime / Lebensdauer Lh [saat] / [hour] / [Stunde]			
	40000	20000	10000	5000
20	27.0	33.3	41.0	50.5
30	23.9	29.5	36.3	44.7
40	22.0	27.0	33.3	41.0
50	20.5	25.3	31.1	38.4
65	19.0	23.4	28.8	35.5
80	17.8	22.0	27.0	33.3
100	16.7	20.5	25.3	31.1
120	15.8	19.4	23.9	29.5
140	15.1	18.6	22.9	28.2
160	14.5	17.8	22.0	27.0
180	14.0	17.2	21.2	26.1
200	13.5	16.7	20.5	25.3
220	13.2	16.2	20.0	24.6
240	12.8	15.8	19.4	23.9
260	12.5	15.4	19.0	23.4
280	12.2	15.1	18.6	22.9
300	12.0	14.8	18.2	22.4
320	11.8	14.5	17.8	22.0

n₂ : Çıkış Devri [d/dak]
Output Speed [rpm]
Abtriebsdrehzahl [U/min]

KRE283				
n ₂	F _{ama} [kN]			
	Ömür / Lifetime / Lebensdauer Lh [saat] / [hour] / [Stunde]			
	40000	20000	10000	5000
20	104.8	129.0	158.8	195.6
30	92.7	114.2	140.6	173.2
40	85.1	104.8	129.0	158.8
50	79.6	98.0	120.6	148.5
65	73.5	90.5	111.5	137.3
80	69.1	85.1	104.8	129.0
100	64.6	79.6	98.0	120.6
120	61.2	75.3	92.7	114.2
140	58.4	71.9	88.5	109.0
160	56.1	69.1	85.1	104.8
180	54.2	66.7	82.1	101.1
200	52.5	64.6	79.6	98.0
220	51.0	62.8	77.3	95.2
240	49.7	61.2	75.3	92.7
260	48.5	59.7	73.5	90.5
280	47.4	58.4	71.9	88.5
300	46.5	57.2	70.4	86.7
320	45.6	56.1	69.1	85.1

n₂ : Çıkış Devri [d/dak]
Output Speed [rpm]
Abtriebsdrehzahl [U/min]

KRE373				
n ₂	F _{ama} [kN]			
	Ömür / Lifetime / Lebensdauer Lh [saat] / [hour] / [Stunde]			
	40000	20000	10000	5000
20	104.8	129.0	158.8	195.6
30	92.7	114.2	140.6	173.2
40	85.1	104.8	129.0	158.8
50	79.6	98.0	120.6	148.5
65	73.5	90.5	111.5	137.3
80	69.1	85.1	104.8	129.0
100	64.6	79.6	98.0	120.6
120	61.2	75.3	92.7	114.2
140	58.4	71.9	88.5	109.0
160	56.1	69.1	85.1	104.8
180	54.2	66.7	82.1	101.1
200	52.5	64.6	79.6	98.0
220	51.0	62.8	77.3	95.2
240	49.7	61.2	75.3	92.7
260	48.5	59.7	73.5	90.5
280	47.4	58.4	71.9	88.5
300	46.5	57.2	70.4	86.7
320	45.6	56.1	69.1	85.1

n₂ : Çıkış Devri [d/dak]
Output Speed [rpm]
Abtriebsdrehzahl [U/min]

KRE473				
n ₂	F _{ama} [kN]			
	Ömür / Lifetime / Lebensdauer Lh [saat] / [hour] / [Stunde]			
	40000	20000	10000	5000
20	134.5	165.6	203.9	251.1
30	119.0	146.6	180.5	222.3
40	109.2	134.5	165.6	203.9
50	102.1	125.7	154.8	190.7
65	94.4	116.2	143.1	176.2
80	88.7	109.2	134.5	165.6
100	82.9	102.1	125.7	154.8
120	78.5	96.7	119.0	146.6
140	75.0	92.3	113.7	140.0
160	72.0	88.7	109.2	134.5
180	69.5	85.6	105.4	129.8
200	67.3	82.9	102.1	125.7
220	65.4	80.6	99.2	122.2
240	63.8	78.5	96.7	119.0
260	62.2	76.6	94.4	116.2
280	60.9	75.0	92.3	113.7
300	59.6	73.4	90.4	111.3
320	58.5	72.0	88.7	109.2

n₂ : Çıkış Devri [d/dak]
Output Speed [rpm]
Abtriebsdrehzahl [U/min]

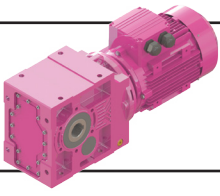

Genel Bilgiler

General Information

Einführung



Ekstruder Tiplerde Müsade Edilebilir Eksenal Yükler

Permissible Axial Loads for Extruder Types
Zulässige Axialkräfte für Extruder Typ Getrieben

KRE573				
n ₂	F _{ama} [kN]			
	Ömür / Lifetime / Lebensdauer Lh [saat] / [hour] / [Stunde]			
	40000	20000	10000	5000
20	172.0	211.8	260.8	779.6
30	152.3	187.5	230.9	715.9
40	139.7	172.0	211.8	673.9
50	130.6	160.8	198.1	643.1
65	120.7	148.7	183.0	608.6
80	113.4	139.7	172.0	582.6
100	106.1	130.6	160.8	555.9
120	100.4	123.7	152.3	535.0
140	95.9	118.1	145.4	518.0
160	92.1	113.4	139.7	503.6
180	88.9	109.5	134.8	491.3
200	86.1	106.1	130.6	480.6
220	83.7	103.1	126.9	471.0
240	81.5	100.4	123.7	462.5
260	79.6	98.0	120.7	454.8
280	77.9	95.9	118.1	447.8
300	76.3	93.9	115.6	441.3
320	74.8	92.1	113.4	435.4

n₂ : Çıkış Devri [d/dak]
Output Speed [rpm]
Abtriebsdrehzahl [U/min]

KRE673				
n ₂	F _{ama} [kN]			
	Ömür / Lifetime / Lebensdauer Lh [saat] / [hour] / [Stunde]			
	40000	20000	10000	5000
20	209.5	258.0	317.7	391.2
30	185.5	228.4	281.3	346.4
40	170.1	209.5	258.0	317.7
50	159.1	195.9	241.3	297.1
65	147.1	181.1	223.0	274.6
80	138.2	170.1	209.5	258.0
100	129.2	159.1	195.9	241.3
120	122.3	150.6	185.5	228.4
140	116.8	143.8	177.1	218.1
160	112.2	138.2	170.1	209.5
180	108.3	133.4	164.2	202.2
200	104.9	129.2	159.1	195.9
220	102.0	125.6	154.6	190.4
240	99.3	122.3	150.6	185.5
260	97.0	119.4	147.1	181.1
280	94.8	116.8	143.8	177.1
300	92.9	114.4	140.9	173.5
320	91.1	112.2	138.2	170.1

n₂ : Çıkış Devri [d/dak]
Output Speed [rpm]
Abtriebsdrehzahl [U/min]

KR773				
n ₂	F _{ama} [kN]			
	Ömür / Lifetime / Lebensdauer Lh [saat] / [hour] / [Stunde]			
	40000	20000	10000	5000
20	350.2	431.3	531.1	653.9
30	310.1	381.8	470.2	579.0
40	284.4	350.2	431.3	531.1
50	266.0	327.5	403.3	496.6
65	245.8	302.7	372.8	459.0
80	231.0	284.4	350.2	431.3
100	216.0	266.0	327.5	403.3
120	204.5	251.8	310.1	381.8
140	195.2	240.4	296.0	364.5
160	187.6	231.0	284.4	350.2
180	181.0	222.9	274.5	338.0
200	175.4	216.0	266.0	327.5
220	170.5	209.9	258.5	318.3
240	166.1	204.5	251.8	310.1
260	162.1	199.6	245.8	302.7
280	158.5	195.2	240.4	296.0
300	155.3	191.2	235.5	290.0
320	152.3	187.6	231.0	284.4

n₂ : Çıkış Devri [d/dak]
Output Speed [rpm]
Abtriebsdrehzahl [U/min]

KRE873				
n ₂	F _{ama} [kN]			
	Ömür / Lifetime / Lebensdauer Lh [saat] / [hour] / [Stunde]			
	40000	20000	10000	5000
20	403.4	496.7	611.7	753.2
30	357.1	439.8	541.5	666.9
40	327.6	403.4	496.7	611.7
50	306.3	377.2	464.5	572.0
65	283.1	348.7	429.3	528.7
80	266.0	327.6	403.4	496.7
100	248.8	306.3	377.2	464.5
120	235.5	290.0	357.1	439.8
140	224.9	276.9	341.0	419.9
160	216.0	266.0	327.6	403.4
180	208.5	256.8	316.2	389.4
200	202.0	248.8	306.3	377.2
220	196.3	241.8	297.7	366.6
240	191.3	235.5	290.0	357.1
260	186.7	229.9	283.1	348.7
280	182.6	224.9	276.9	341.0
300	178.9	220.3	271.2	334.0
320	175.4	216.0	266.0	327.6

n₂ : Çıkış Devri [d/dak]
Output Speed [rpm]
Abtriebsdrehzahl [U/min]

KRE973				
n ₂	F _{ama} [kN]			
	Ömür / Lifetime / Lebensdauer Lh [saat] / [hour] / [Stunde]			
	40000	20000	10000	5000
20	519.1	639.2	787.1	969.2
30	459.6	565.9	696.9	858.1
40	421.5	519.1	639.2	787.1
50	394.2	485.4	597.8	736.1
65	364.3	448.7	552.5	680.3
80	342.3	421.5	519.1	639.2
100	320.1	394.2	485.4	597.8
120	303.1	373.2	459.6	565.9
140	289.4	356.3	438.8	540.3
160	278.0	342.3	421.5	519.1
180	268.3	330.4	406.9	501.0
200	260.0	320.1	394.2	485.4
220	252.6	311.1	383.1	471.7
240	246.1	303.1	373.2	459.6
260	240.3	295.9	364.3	448.7
280	235.0	289.4	356.3	438.8
300	230.2	283.4	349.0	429.8
320	225.8	278.0	342.3	421.5

n₂ : Çıkış Devri [d/dak]
Output Speed [rpm]
Abtriebsdrehzahl [U/min]

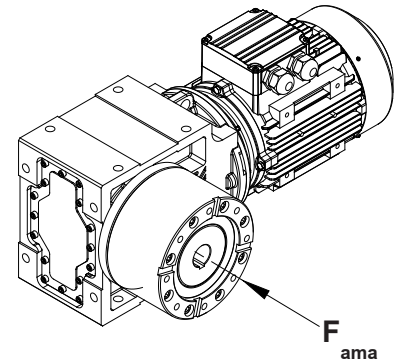

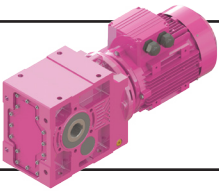

Genel Bilgiler

General Information

Einführung



Eşdeğer Güç Hesabı

Sabit devirde, ancak değişken momentlerde (güçlerde) çalışan redüktörler için eşdeğer tork altındaki, eşdeğer güç hesaplanabilir. Bu eşdeğer güç kullanılarak bilinen sabit güçteki redüktör seçim yöntemi kullanılarak seçim yapılabilir. Burada ağırlıklı torka göre eşdeğer anma torku belirlenmektedir. Hesaplanan bu güçte çalışan redüktör, teorik olarak, değişken yüklerde çalışan redüktör ile aynı emniyet değerine ve ömre sahiptir.

Bir çevrim boyunca oluşan değişken torklar, en yüksek torktan, en düşüğe doğru yatay zaman eksenini boyunca sıralanır (bakınız alttaki şekil). Bu şekile göre eşdeğer tork şu formül ile hesaplanır;

$$T_e = \left(\frac{\Delta t_1 \times T_1^{6.6} + \dots + \Delta t_n \times T_n^{6.6}}{t} \right)^{\frac{1}{6.6}}$$

Eğer T_n değerleri (en düşük tork), T_e 'nin 0,5 katının altında ise, bu tork dilimi yok sayılarak, işlem tekrarlanır;

Eğer $T_n < T_e \times 0.5$ ise

$$T_e = \left(\frac{\Delta t_1 \times T_1^{6.6} + \dots + \Delta t_{n-1} \times T_{n-1}^{6.6}}{t - \Delta t_n} \right)^{\frac{1}{6.6}}$$

Tüm T_n değerleri T_e 'nin 0,5 katının üzerinde ise, eşdeğer güç aşağıdaki gibi hesaplanır;

$$P_{eq} = P_N = \frac{T_e \times n}{9550}$$

Eşdeğer gücün bulunmasından sonra eşdeğer güç değeri kullanılarak, bu katalogta verilen redüktör seçimi bölümünde anlatılan adımlar uygulanarak redüktör seçimi tamamlanır.

Equivalent Power Rating Calculation

The equivalent power by an equivalent constant torque can be calculated for gearboxes working in constant speed but variable torques (or powers). Using this equivalent power it is possible to make a gearbox selection according to the usual gearbox selection method with constant torques. The equivalent torque will be determined according to the mean of dominating torques. The gearbox working in constant equivalent torque will theoretically have the same lifetime and safety compared to the variable torque one.

To calculate the equivalent torques, the variable torques in a cycle must be sorted from the maximal to the minimal on a horizontal time line (Check the graphic below). According to the graphic below the equivalent torque can be calculated with the following formula;

$$T_e = \left(\frac{\Delta t_1 \times T_1^{6.6} + \dots + \Delta t_n \times T_n^{6.6}}{t} \right)^{\frac{1}{6.6}}$$

If T_n (the lowest torque) is lower than 50 % of T_e , this torque part must be taken out of the torque graph and the calculation must be repeated;

If $T_n < T_e \times 0.5$ then

$$T_e = \left(\frac{\Delta t_1 \times T_1^{6.6} + \dots + \Delta t_{n-1} \times T_{n-1}^{6.6}}{t - \Delta t_n} \right)^{\frac{1}{6.6}}$$

If all T_n values are higher than 50% of T_e then the equivalent power can be calculated by the following formula;

$$P_{eq} = P_N = \frac{T_e \times n}{9550}$$

After the equivalent power is determined the selection of gearbox is made according to the selection procedures given on the gearbox selection part in this catalogue.

Berechnung äquivalenter Leistung

Die äquivalente Leistung bei äquivalenten Drehmoment kann für Getrieben mit konstanten Drehzahl und variablen Momente berechnet werden. Mit dieser Leistung kann das Getriebe ausgelegt werden, wie bei konstanten Leistung. Man bestimmt hiermit also die maßgebende Belastung. Das ausgelegte Getriebe erreicht theoretisch dem gleichen Lebensdauer und hat die gleiche Sicherheit.

Für die Berechnung der äquivalenten Drehmoment müssen die einzelnen Drehmomentanteile auf eine Zeitachse von größten bis zu kleinsten angeordnet werden (siehe unteres Bild). Das äquivalente Drehmoment wird nach folgender Formel berechnet;

$$T_e = \left(\frac{\Delta t_1 \times T_1^{6.6} + \dots + \Delta t_n \times T_n^{6.6}}{t} \right)^{\frac{1}{6.6}}$$

Wenn T_n (niedrigstes Drehmoment) kleiner als 50% von T_e ist, muss dieser Anteil vernachlässigt werden und die Berechnung soll neu durchgeführt werden;

Wenn $T_n < T_e \times 0.5$ dann

$$T_e = \left(\frac{\Delta t_1 \times T_1^{6.6} + \dots + \Delta t_{n-1} \times T_{n-1}^{6.6}}{t - \Delta t_n} \right)^{\frac{1}{6.6}}$$

Wenn alle T_n Werte höher als 50% von T_e sind, dann wird die äquivalente Leistung nach folgender Formel berechnet;

$$P_{eq} = P_N = \frac{T_e \times n}{9550}$$

Nach Bestimmung der äquivalenter Leistung, erfolgt die Getriebeauslegung wie bei konstanter Leistung. Die Auswahlverfahren für konstante Leistung ist in diesem Katalog angegeben.

(Moment / Torque / Moment)

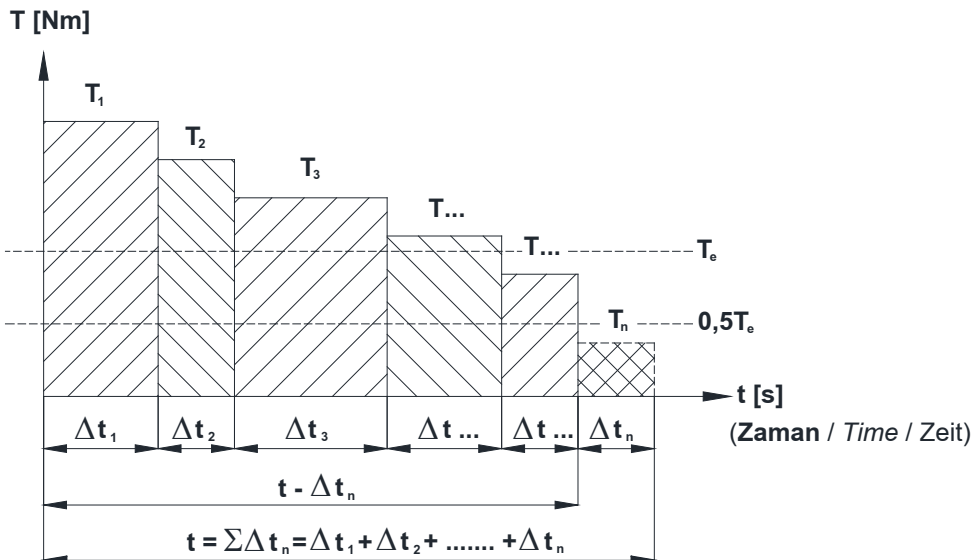

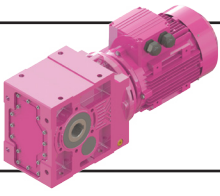

Genel Bilgiler

General Information

Einführung



Eşdeğer Güç Hesabı Örneği

Çift yönlü çalışan ham demir haddesi için aşağıdaki çalışma koşulları belirlenmiş;

Veriler:

Toplam bir iş çevrimi: 2 dak.

1. Yük kademesi: 48 kNm, 30 sn
2. Yük Kademesi: 32 kNm, 22 sn
3. Yük Kademesi: 28 kNm, 15 sn
4. Yük Kademesi: 16 kNm, 10 sn
5. Yük Kademesi: 5 kNm, 43sn

Makina sabit devri: 50 d/dak

Redüktör seçimine esas olacak eşdeğer yük aranmaktadır.

Çözüm:

Bir çevrimin toplam zamanı;

$$t = t_1 + t_2 + t_3 + t_4 + t_5 = 120 \text{ sn}$$

Eşdeğer Tork;

$$T_e = \left(\frac{30 \times 48^{6,6} + \dots + 43 \times 5^{6,6}}{120} \right)^{\frac{1}{6,6}}$$

$$= 39,2 \text{ kNm}$$

%50 eşdeğer tork;

$$0,5 \times T_e = 19,6 \text{ kNm}$$

Her bir tork dilimi bu değer üzerinde olmalı

$$T_{4,5} < 0,5 \times T_e$$

%50 torkun altındakileri çıkararak hesabı tekrarlayalım;

$$t' = t_1 - t_4 - t_5 = 120 - 43 - 10 = 67 \text{ s}$$

$$T_e = \left(\frac{30 \times 48^{6,6} + 22 \times 32^{6,6} + 15 \times 28^{6,6}}{67} \right)^{\frac{1}{6,6}}$$

$$= 42,9 \text{ kNm}$$

Moment ve devir değerlerini kullanarak eşdeğer gücümüzü hesaplayalım;

$$P_{eq} = \frac{T_e \times n}{9550} = \frac{42,9 \times 1000 \times 50}{9550} = 225 \text{ kW}$$

Yukarıdaki güç ve devir değeri kullanılarak bu katalogta anlatılan seçim prosedürü ile redüktör seçimi yapılabilir.

Equivalent Power Rating Sample

The following data is given for a reversing blooming mill;

Torque steps:

Total one cycle time: 2 min.

- 1st torque part: 48 kNm, 30 s
- 2nd torque part: 32 kNm, 22 s
- 3th torque part: 28 kNm, 15 s
- 4th torque part: 16 kNm, 10 s
- 5th torque part: 5 kNm, 43 s

Machine constant speed: 50 rpm

The equivalent power, which is required for gear unit selection, is to determine.

Solution:

Total time in a cycle;

$$t = t_1 + t_2 + t_3 + t_4 + t_5 = 120 \text{ sn}$$

Equivalent Torque;

$$T_e = \left(\frac{30 \times 48^{6,6} + \dots + 43 \times 5^{6,6}}{120} \right)^{\frac{1}{6,6}}$$

$$= 39,2 \text{ kNm}$$

50% of Equivalent torque;

$$0,5 \times T_e = 19,6 \text{ kNm}$$

Every torque part must be lower then this value;

$$T_{4,5} < 0,5 \times T_e$$

We are repeating the calculation by taking out the torque parts, which are below 50%;

$$t' = t_1 - t_4 - t_5 = 120 - 43 - 10 = 67 \text{ s}$$

$$T_e = \left(\frac{30 \times 48^{6,6} + 22 \times 32^{6,6} + 15 \times 28^{6,6}}{67} \right)^{\frac{1}{6,6}}$$

$$= 42,9 \text{ kNm}$$

By using the equivalent torque and constant speed we calculate the equivalent power;

$$P_{eq} = \frac{T_e \times n}{9550} = \frac{42,9 \times 1000 \times 50}{9550} = 225 \text{ kW}$$

Now by using the above calculated equivalent power and constant speed we camake the gear-box selection with the procedures described in this catalogue.

Beispiel für äquivalente Leistung

Die nachfolgenden Angaben sind für eine Blechreversierwalze;

Drehmoment stufen:

Gesamte Zeit für einem Arbeitszyklus: 2 min.

- Drehmomentanteil 1: 48 kNm 30 s
- Drehmomentanteil 2: 32 kNm 22 s
- Drehmomentanteil 3: 28 kNm 15 s
- Drehmomentanteil 4: 16 kNm 10 s
- Drehmomentanteil 5: 5 kNm 43 s

Maschine hat konstante Drehzahl: 50 U/min

Gesucht ist die äquivalente Leistung, die für die Getriebeauslegung nötig ist.

Lösung:

Gesamte Zeit für einem Arbeitszyklus;

$$t = t_1 + t_2 + t_3 + t_4 + t_5 = 120 \text{ sn}$$

Äquivalentes Drehmoment;

$$T_e = \left(\frac{30 \times 48^{6,6} + \dots + 43 \times 5^{6,6}}{120} \right)^{\frac{1}{6,6}}$$

$$= 39,2 \text{ kNm}$$

50% von äquivalenten Drehmoment;

$$0,5 \times T_e = 19,6 \text{ kNm}$$

Drehmomentanteile müssen größer als dieser Wert sein;

$$T_{4,5} < 0,5 \times T_e$$

Wir wiederholen die Berechnung nochmals ohne die kleine Drehmomentanteile;

$$t' = t_1 - t_4 - t_5 = 120 - 43 - 10 = 67 \text{ s}$$

$$T_e = \left(\frac{30 \times 48^{6,6} + 22 \times 32^{6,6} + 15 \times 28^{6,6}}{67} \right)^{\frac{1}{6,6}}$$

$$= 42,9 \text{ kNm}$$

Mit Hilfe von äquivalenten Drehmoment und konstanter Drehzahl berechnet man die äquivalente Leistung;

$$P_{eq} = \frac{T_e \times n}{9550} = \frac{42,9 \times 1000 \times 50}{9550} = 225 \text{ kW}$$

Nach Bestimmung der äquivalente Leistung und konstanter Drehzahl, erfolgt die Getriebeauslegung dann wie die Getriebeauswahl gemäß dem in diesem Katalog beschriebenen Verfahren für konstante Leistung.

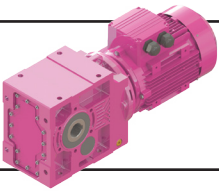

Genel Bilgiler

General Information

Einführung



Redüktör Seçimi

Bir redüktör seçiminde aşağıdaki yol izlenmelidir.

1. Çalışma şartlarına bağlı olarak servis faktörünü (fs) belirleyiniz. (Servis Faktörü Sayfa 16).

2. Makinanız için gerekli olan momenti belirleyiniz M_2 (redüktör gerekli çıkış momenti).

3. Makinanızın devrini belirleyiniz n_2 (redüktör gerekli çıkış devri).

4. Makinanızın güç ihtiyacını (Redüktör çıkış gücünü) " P_2 " hesaplayınız.

$$P_2 = \frac{M_2 \times n_2}{9550}$$

5. Redüktör ile makina arasında kullanılan bağlantı elemanına göre radyal yükü hesaplayınız. (Sayfa 20). Yukarıdaki verilere uygun olarak çıkış devri, değerlerine uyan servis faktörü ve radyal yükü bulduğunuzdan daha yüksek veya eşit olan redüktörü, güç-devir seçim tablolarından seçiniz. Helisel tip redüktörlerde verim yüksek olduğundan çıkış gücü verilmemiştir. Hesapladığınız güç değerini giriş gücü olarak kabul edip seçiminizi yapınız. Tablolarda verilen M_2 çıkış momentinin hesapladığınız M_2 den büyük olmasına dikkat ediniz. Eğer seçilen redüktörünki daha ufak ise bir üst motor gücüne geçiniz.

Örnek

1. Makina Cinsi:

Lastik bantlı konveyör , dökme yük taşıyor.

2. Makina için gerekli moment:

Makina için hesaplanan moment $M_2 = 470$ Nm.

3. Makina gerekli çıkış devri:

$n_2 = 50$ dev/dak.

4. Günlük çalışma süresi:

16 saat.

5. Saatte start sayısı:

Saatte 1 start

6. Makina ile bağlantı şekli:

Zincir dişli (çap -130 mm)

- Yük sınıflandırma tablosundan yük sınıfı M olarak seçilir (sayfa 17-18)

- Günlük çalışma süresi 16 saat Saatte start sayısı 1 ve yük sınıfı M'ye tekabül eden servis faktörü tablosundan, servis faktörü için $fs = 1.3$ değeri bulunur.(sayfa 16)

- Makinanızın güç ihtiyacı (Redüktör Çıkış Gücü) :

$$P_2 = \frac{M_2 \times n_2}{9550} = \frac{470 \times 50}{9550} = 2,46 \text{ kW}$$

Gearbox Selection

For the correct selection of the appropriate gear units follow this steps.

1.Determine service factor (fs) on the basis of running conditions (Page 16).

2. Determine the required Torque M_2 (required output torque of gearbox) for the driven machine.

3. Determine required speed (output speed of gearbox) for the driven machine.

4. Calculate the required power for your machine(Calculate power " P_2 " required at output side of gear reducer using the formula);

$$P_2 = \frac{M_2 \times n_2}{9550}$$

5. Calculate overhung load required at output shaft according to type of connection between gear unit and machine (Refer to directions and values given on page 20). After determining the above mentioned values, the gear reducer which corresponds to our requirements can be selected from the performance tables (the service factor and the permissible overhung load should be less than or equal to our requirement). For Helical gears the output power is not given on the performance tables because they have high efficiency and the output power can be taken as input power. The output torque should be checked if it meets to our requirements. If the output torque is low, search for a higher input power gearbox.

Example:

1. Machine Type:

Belt Conveyor (Bulk Load)

2. Required Torque:

Required Torque calculated for the driven machine is $M_2=470$ Nm.

3. Required speed:

$n_2 = 50$ rpm

4. Running time:

16 hours per day

5. Frequency of starting:

1 start per hour

6. Connection type between gear reducer

Chain drive (output dimension-130 mm)

- From the load classification table (on page 17-18), the load class M can be selected for the known application.

- The service factor can be selected as $fs = 1,3$ from the service factor table (page 16) by taking into consideration 16 hours running time, one start per hour, and load class M.

-Required power for your machine(Power at output side of gear reducer) :

$$P_2 = \frac{M_2 \times n_2}{9550} = \frac{470 \times 50}{9550} = 2,46 \text{ kW}$$

Getriebeauswahl

Für die korrekte Auswahl des Antriebes;

1. Den Betriebsfaktor(fs) in Abhängigkeit von den Betriebsbedingungen bestimmen.(Bezug auf Seite 16).

2. Die erforderte Drehmoment M_2 für die angetriebene Maschine (Abtriebsdrehmoment für die Getriebe) bestimmen.

3. Erforderte Drehzahl bestimmen (Abtriebsdrehzahl für die Getriebe).

4. Berechnen der erforderte Leistung der angetriebene Maschine (Die an der Abtriebswelle erforderte Leistung " P_2 ") mit der unten angegebenen Formel.

$$P_2 = \frac{M_2 \times n_2}{9550}$$

5. Die an der Getriebeabtriebswelle erforderte Querkraft in Abhängigkeit von Antriebsselement bestimmen (Bezug auf Seite 20). Nach Bestimmen der oben angegebenen Werte, die passende Getriebe kann von den angegebenen Leistungstabellen entnommen werden. Dabei soll darauf geachtet werden, dass der Betriebsfaktor und Querkraft stets unterhalb von angegebenen Werten liegt. Weil Stirnradgetrieben einen hohen Wirkungsgrad haben, sind die Abtriebsleistungen für Stirnradgetrieben nicht angegeben. Bei dieser Getrieben die erforderte Leistung kann als Antriebsleistung benutzt werden. Achten sie darauf, dass der Abtriebsmoment größer als die erforderte Drehmoment ist.

Beispiel:

1. Maschinentyp:

Gurtbandförderer (Schüttgut)

2. Erforderte Drehmoment:

Für die Maschine berechnete Drehmoment $M_2 = 470$ Nm.

3. Erforderte Drehzahl:

$n_2 = 50$ upm

4. Betriebsdauer:

16 stunden pro Tag

5. Schalthäufigkeit:

1 Start pro Stunde

6. Antriebselement für verbindung

Getriebe-Machine:Kettentrieb(Durchmesser-130 mm)

- Von den Belastungsart Tabellen(Seite 17-18) nimmt man Belastungsart M

- Für den Schaltungszahl 1 und die Laufzeit16 und für den passenden Belastungsart erhält man Betriebsfaktor $fs = 1,3$ von Tabelle auf Seite 16.

- Erforderte Leistung der angetriebe Maschine (Die an der Getriebeabtriebswelle erforderte Leistung)

$$P_2 = \frac{M_2 \times n_2}{9550} = \frac{470 \times 50}{9550} = 2,46 \text{ kW}$$

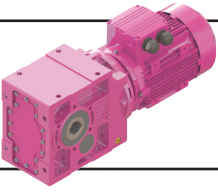

Genel Bilgiler General Information Einführung



- Zincir dişli uygulaması için (Sayfa 21) Fq değeri;

$$F_q = \frac{2100 \times M_2}{D} = \frac{2100 \times 470}{130} = 7592 \text{ N}$$

- Ortaya çıkan redüktör ihtiyacı

$$\begin{aligned} P_2 &\geq 2,46 \text{ kW} \\ M_2 &\geq 470 \text{ Nm} \\ fs &\geq 1.3 \\ n_2 &\approx 50 \text{ d/dak} \\ Fq &\geq 7592 \text{ N} \end{aligned}$$

Güç ve devir sayfalarından,

KR373-3E100L/4D seçilir (Sayfa 75).

$$\begin{aligned} P_2 &= 3 \text{ kW} > 2,46 \text{ kW} \\ M_2 &= 537 \text{ Nm} > 470 \text{ Nm} \\ fs &= 1,5 \\ n_2 &= 50 \text{ d/dak} \\ fq &= 14875 \text{ Nm} > 7592 \text{ Nm} \\ i &= 28,85 \end{aligned}$$

- For chain drive application the requested overhang load can be calculated from (page 21);

$$F_q = \frac{2100 \times M_2}{D} = \frac{2100 \times 470}{130} = 7592 \text{ N}$$

- The required gearbox is as follows:

$$\begin{aligned} P_2 &\geq 2,46 \text{ kW} \\ M_2 &\geq 470 \text{ Nm} \\ fs &\geq 1.3 \\ n_2 &\approx 50 \text{ rpm} \\ Fq &\geq 7592 \text{ N} \end{aligned}$$

From the performance table,

KR373-3E100L/4D selected (Page 75).

$$\begin{aligned} P_2 &= 3 \text{ kW} > 2,46 \text{ kW} \\ M_2 &= 537 \text{ Nm} > 470 \text{ Nm} \\ fs &= 1,5 \\ n_2 &= 50 \text{ d/dak} \\ fq &= 14875 \text{ Nm} > 7592 \text{ Nm} \\ i &= 28,85 \end{aligned}$$

- Für Kettentrieb die erforderte Querkraft (seite 21);

$$F_q = \frac{2100 \times M_2}{D} = \frac{2100 \times 470}{130} = 7592 \text{ N}$$

- Von den oben angegebenen Berechnungen die erforderte Getriebe ist wie folgt;

$$\begin{aligned} P_2 &\geq 2,46 \text{ kW} \\ M_2 &\geq 470 \text{ Nm} \\ fs &\geq 1.3 \\ n_2 &\approx 50 \text{ U/min} \\ Fq &\geq 7592 \text{ N} \end{aligned}$$

Von der Leistung- DrehzahlTabelle ,

wurde **KR373-3E100L/4D** gewählt (Seite 75).

$$\begin{aligned} P_2 &= 3 \text{ kW} > 2,46 \text{ kW} \\ M_2 &= 537 \text{ Nm} > 470 \text{ Nm} \\ fs &= 1,5 \\ n_2 &= 50 \text{ d/dak} \\ fq &= 14875 \text{ Nm} > 7592 \text{ Nm} \\ i &= 28,85 \end{aligned}$$

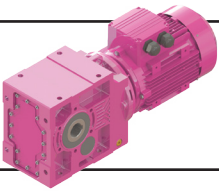

Genel Bilgiler

General Information

Einführung



Redüktör Seçim Formu

Kullanıldığı Sektör.....
Kullanıldığı Yer.....
Gerekli Ortalama Devir.....d/dak

Makina ihtiyaç gücü:

-Normal..... kW
-En çok..... kW
-En az..... kW

Tahrik Şekli:

AC Motor []
AC Motor + Invertör []
DC Motor []
Hidromotor []
1-3 silindri içten yanmalı []
2-4 silindri içten yanmalı []

Motor Bağlantı Şekli (Elektrik Motorları):

IEC B5 Flanşlı []
NEMA Flanşlı []

IEC veya NEMA flanş kodu.....

Motor Gücü:

-Nominal..... kW

Motor Devri:

-Normal..... d/dak
-En çok..... d/dak
-En az..... d/dak

Motor Torku:

-Normal..... Nm
-En çok..... Nm
-En az..... Nm

Dönüş şekli:

saat yönü [] saat yönüne ters [] değişken []

Günlük çalışma süresi:

<4 [] 4-8 [] 8-16 [] >16 []

Saatteki start sayısı:

0-50 [] 50-100 [] 100-200 []
200-300 [] 300-500 [] 500-700 []
700-1000 [] >1000 []

Motor Redüktör Arası Tahvil Oranı.....

Kalkış için gerekli moment.....Nm

Saatteki pik moment adedi:

1-5 [] 6-30 [] 31-100 [] >100 []

Bir çevrimde aktif çalışma oranı (ED):

%100 [] %80 [] %60 [] 40% [] %20 []

Deniz seviyesinden yükseklik:

<1000 [] <2000 [] <3000 []
<4000 [] <5000 []

Montaj yeri:

Küçük kapalı oda (w<1m/sn) []
Kapalı oda (w<3m/sn) []
Büyük oda ve holler (w>=3m/sn) []
Tamamen açık ortam []

Çevre Şartları:

Normal [] Tozlu [] Nemli []
Korozif [] Kuru []

Çevre Sıcaklığı:

Ortalama..... °C
En Yüksek..... °C
En Düşük..... °C

Kilit İhtiyacı:

Var [] Yok []

Redüktör Giriş Opsiyonu:

R.. [] V.. [] N.. [] T.. []

Redüktör Çıkış Opsiyonu:

00 [] 01 [] 02 [] 03 [] 04 [] 05 [] 08 []
0S [] 0E []

Montaj Pozisyonu:

M1 [] M2 [] M3 [] M4 [] M5 [] M6 []

Giriş mili bağlantı şekli:

Elastik kaplin []
Fıçı tipi kaplin []
Rijit kaplin []
Hidrolik Kaplin []
Kayış kasnak []
Zincir dişli []
Pinyon dişli []
Bağlantı elemanı çapı.....mm
Radyal yükü.....N
Radyal yük "u" mesafesi.....mm
Aksiyal yükü (mile doğru +).....N

Çıkış mili bağlantı şekli:

Elastik kaplin []
Fıçı tipi kaplin []
Rijit kaplin []
Kayış kasnak []
Zincir dişli []
Pinyon dişli []
Delik milli tork kolu []
Sıkma bilezikli tork kolu []
Bağlantı elemanı çapı.....mm
Radyal yükü.....N
Radyal yük "u" mesafesi.....mm
Aksiyal yükü (mile doğru +).....N

Çıkış Mili Özelliği:

Dolu Mil Kamalı []
Dolu Mil Kamasız []
Delik Milli Sıkma Bilezikli []
Delik Milli []
Özel Mil []

Giriş Mili Özelliği:

Kamalı []
Kamasız düz mil []
Özel Mil []
Tork kolu [] Var [] Yok []

Elektrik Gerilimi:

AC-Monofaze [] AC-Trifaze [] DC []
Voltaj..... Volt
Frekans..... Hz

Koruma Sınıfı:

IP55 [] IP65 [] Exproof []
Diğer IP.....

Ekler:

Yük diyagramı []
Proje []
İstenen ana boyutlar []
Teknik veriler []

Diğer Notlar:

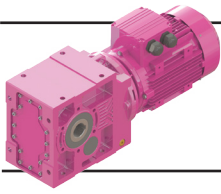

Genel Bilgiler

General Information

Einführung



Gearbox Selection Form

Field of Industry.....
 Application.....
 Required Average Speed..... rpm

Required Power on Driven Machine:

-Normal..... kW
 -Maximum..... kW
 -Minimum..... kW

Driving Machine:

AC Motor []
 AC Motor + Inverter []
 DC Motor []
 Hydraulic Motor []
 Piston Engine with 1-3 cylinder []
 Piston Engine with 4-24 cylinder []

Motor Connection Type (Electric Motors):

IEC B5 Flange []
 NEMA Flange []

IEC or NEMA Flange Code.....

Motor Power:

-Nominal.....kW

Motor Speed:

-Normal.....rpm
 -Maximum.....rpm
 -Minimum.....rpm

Motor Torque:

-Normal.....Nm
 -Maximum.....Nm
 -Minimum.....Nm

Direction of Rotation:

cw [] ccw [] variable []

Working hours per day:

<4 [] 4-8 [] 8-16 [] >16 []

Startings per cycle:

0-50 [] 50-100 [] 100-200 []
 200-300 [] 300-500 [] 500-700 []
 700-1000 [] >1000 []

Transmission ratio between motor and gear unit.....

Required Starting Torque.....Nm

Peak torques per hour:

1-5 [] 6-30 [] 31-100 [] >100 []

Effective working time in a cycle (ED):

%100 [] %80 [] %60 [] 40% []
 20% []

Altitude:

<1000 [] <2000 [] <3000 []
 <4000 [] <5000 []

Mounting Place:

Small closed room (w<1m/sn) []
 Closed room (w<3m/sn) []
 Big rooms and halls (w>=3m/sn) []
 Outdoor []

Ambient Conditions:

Normal [] Dusty [] Humid []
 Corrosive [] Dry []

Ambient Temperature:

Average.....°C
 Maximum.....°C
 Minimum.....°C

Backstop Required:

Yes [] No []

Gearbox input options:

R.. [] V.. [] N.. [] T.. []

Gearbox output options:

00 [] 01 [] 02 [] 03 [] 04 [] 05 [] 08 []
 0S [] 0E []

Mounting Position:

M1 [] M2 [] M3 [] M4 [] M5 [] M6 []

Input Shaft Connection Type:

Elastic Coupling []
 Barrel Type Coupling []
 Hydraulic Coupling []
 Rigid Flange Coupling []
 Pulley []
 Chain Sprocket []
 Pinion []
 Diameter of Connection element.....mm
 Radial Load.....N
 "u" Distance of Radial Load.....mm
 Axial Load (Towards Shaft)N

Output Shaft Connection Type:

Elastic Coupling []
 Barrel Type Coupling []
 Rigid Flange Coupling []
 Pulley []
 Chain Sprocket []
 Pinion []
 Hollow Shaft with Torque Arm []
 Shrinck disc with Torque Arm []
 Diameter of Connection Element.....mm
 Radial Load.....N
 "u" Distance of Radial Load.....mm
 Axial Load (Towards Shaft)N

Gearbox assembled by:

Foot [] Flange [] Torque Arm []

Output Shaft Specification:

Solid Shaft with Keyway []
 Solid Shaft without Keyway []
 Hollow Shaft with Shrinck Disc []
 Hollow Shaft []
 Special Shaft []

Input Shaft Specification:

Solid Shaft with Keyway []
 Solid Shaft without Keyway []
 Special Shaft []
 Torque arm required Yes [] No []

Electrical Supply:

AC-1 Phase [] AC-3 Phase [] DC []
 Voltage.....Volt
 Frequency..... Hz

Protection Class:

IP55 [] IP65 [] Exproof []
 Other IP.....

Attachments:

Load Diagram []
 Project []
 Required Dimensions []
 Technical Specifications []

Notes:

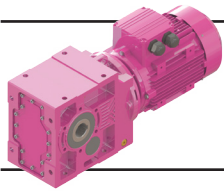

Genel Bilgiler

General Information

Einführung



Formular für Getriebeauswahl

Industriebereich.....
 Anwendung.....
 Erforderliche Drehzahl.....U/min

Erforderliche Leistung für die Maschine:

-Normal.....kW
 -Minimal.....kW
 -Maximal.....kW

Antriebsmaschine:

AC Motor []
 AC Motor mit Frequenzumrichter []
 DC Motor []
 Hydromotor []
 Kolbenmaschinen mit 1-3 Zylinder []
 Kolbenmaschinen mit 2-4 Zylinder []

Motorverbindungsart (Elektromotoren):

IEC B5 Flansch []
 NEMA Flansch []

IEC oder NEMA Flanschcode.....

Motorleistung:

-Nominal.....kW

Motordrehzahl:

-Normal.....U/min
 -Maximal.....U/min
 -Minimal.....U/min

Motordrehmoment:

-Normal.....Nm
 -Maximal.....Nm
 -Minimal.....Nm

Drehrichtung:

in Uhrzeigersinn [] gegen Uhrzeigersinn []
 veränderlich []

Betriebsdauer in Stunden pro Tag:

<4 [] 4-8 [] 8-16 [] >16 []

Anzahl der Anläufe pro Stunde:

0-50 [] 50-100 [] 100-200 []
 200-300 [] 300-500 [] 500-700 []
 700-1000 [] >1000 []

Übersetzung zwischen Motor und Antriebswelle.....

Erforderliches Anlaufmoment.....Nm

Häufigkeit von Lastspitzen pro Stunde:

1-5 [] 6-30 [] 31-100 [] >100 []

Einschaltdauer je Stunde (ED):

%100 [] %80 [] %60 [] 40% [] %20 []

Höhenlage über Meeresspiegel (m):

<1000 [] <2000 [] <3000 []
 <4000 [] <5000 []

Betriebsort:

Kleine geschlossene Räume (w<1m/sn) []
 Geschlossene Räume (w<3m/sn) []
 Große Räume und Hallen (w>=3m/sn) []
 im Freien []

Umgebungsbedingungen:

Normal [] Staubig [] Feucht []
 Korrodierend [] Trocken [] Verklebend []

Umgebungstemperatur:

Mittelwert.....°C
 Maximal.....°C
 Minimal.....°C

Rücklauf Sperre erforderlich:

Ja [] Nein []

Getriebeeingangsvarianten:

R.. [] V.. [] N.. [] T.. []

Getriebeausgangsvarianten:

00 [] 01 [] 02 [] 03 [] 04 [] 05 [] 08 []
 0S [] 0E []

Montageposition:

M1 [] M2 [] M3 [] M4 [] M5 [] M6 []

Antriebswellenanschluss:

Elastische Kupplung []
 Trommelkupplung []
 Hydrokupplung []
 Starre Flanschkupplung []
 Riementrieb []
 Kettenrad []
 Ritzel []
 Durchmesser von Anschlusselement.....mm
 Querkraft.....N
 "u" Abstand von der Wellenschulter.....mm
 Axialkraft (in Richtung der Welle +)N

Abtriebswellenanschluss:

Elastische Kupplung []
 Trommelkupplung []
 Starre Flanschkupplung []
 Riementrieb []
 Kettenrad []
 Ritzel []
 Hohlwelle mit Drehmomentstütze []
 Schrumpfscheibe mit Drehmomentstütze []
 Durchmesser von Anschlusselement.....mm
 Querkraft.....N
 "u" Abstand von der Wellenschulter.....mm
 Axialkraft (in Richtung der Welle +)N

Montage zur Getriebegehäuse mit:

Fuß [] Flansch [] Drehmomentstütze []

Eigenschaften der Abtriebswelle:

Vollwelle mit Passfeder []
 Vollwelle ohne Passfeder []
 Hohlwelle mit Schrumpfscheibe []
 Hohlwelle []
 Sonderwelle []

Eigenschaften der Antriebswelle:

Vollwelle mit Paßfeder []
 Vollwelle ohne Paßfeder []
 Sonderwelle []
 Drehmomentstütze erforderlich Ja [] Nein []

Spannungsversorgung:

AC-1 phasig [] AC-3 phasig [] DC []
 Spannung.....Volt
 Frequenz.....Hz

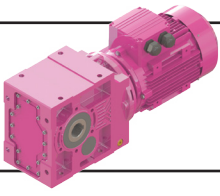

Genel Bilgiler

General Information

Einführung



Yağlama

Redüktörlerin uzun ömürlü olması ve iyi performansla çalışabilmesi için, kullanılan yağın seçimi doğru olmalı ve belirtilen zamanlarda değişimleri yapılmalıdır.

Yağın seçiminde devir, çevre sıcaklığı, redüktör yağ sıcaklığı, çalışma koşulları ve yağ ömrü önem taşımaktadır. Redüktörler yağlı doldurulmuş olarak sevkedilmektedir. Redüktörler uzun süre depolanacakları zaman veya çalışmaya başlanacağı zaman çalışma konumuna göre üstte kalan tapa sökülmesi ve redüktörün beraberinde verilen havalandırma tapası kullanılmalıdır. Bu redüktörün iç basıncından dolayı oluşacak yağ sızmalarını önleyecektir.

Redüktörlerde standart olarak kullanılan yağlar 33. sayfadaki tabloda verilmiştir. Miktarlar ve yağ tipi burada verilen değerlerden farklılık gösterebilir. Redüktörünüzde kullanılan yağın tipi ve miktarı için lütfen etiketine bakınız. Ayaklı redüktörler ve flanşlı redüktörler M1 pozisyonuna göre yağ ile doldurulmuştur. Bu pozisyonlar dışındaki çalışma durumlarında tablolarda verilen yağ miktarlarına göre ilave veya eksiltme yapılmalıdır. Özel çalışma koşullarında firmamıza danışmanız tavsiye edilir.

Mineral yağlar her 10.000 çalışma saatinde, sentetik yağlar ise her 20.000 çalışma saatinde değiştirilmelidir. Ağır çevre koşullarında (ani ısı değişiklikleri, yüksek nemlilik v.b) yağ değiştirme periyotlarının kısaltılması tavsiye edilir. Mineral yağlar ile sentetik yağlar birbirine kesinlikle karıştırılmamalıdır. Değiştirme işlemi bir çalışma periyodunun hemen peşinden ve yağ sıcakken yapılmalıdır. Bu şekilde bir değiştirme, redüktör içindeki partiküllerin yağa karışmış olarak bulunmasından dolayı iyi bir temizleme ve yağın rahat boşalması neticesini verecektir.

Lubrication

To work in perfect condition and to have long life for the gear box the lubricant must be chosen correctly and changed in time.

In selection of oil it is important to consider speed, ambient temperature, gear box oil temperature, working conditions and the life required from the lubricant. All units are filled with lubricant before shipping. Before the gearbox is stored for a long time or before starting up, the top plug (according to the working position) must be removed and the extra given vent plug must be replaced. This prevents excessive pressure which causes oil leakages.

The lubricant in the standard line is given for standard fillings on the table on page 33. Please look at your gear units label for filled oil type and quantity. The foot mounting type gear boxes and where the flange mounted gear boxes are filled for mounting position of M1. For other mounting positions please refer to the table given on the next pages. For special working conditions please contact us.

The mineral lubricant should be changed after every 10.000 service hours and the synthetic lubricant should be changed after every 20.000 working hours. If the operation conditions are very heavy (e.g. high temperature differences, high humidity) shorter intervals between changes are recommended. Mineral and synthetic oils must not be mixed up. By changing the lubricant complete cleaning is advised. The oil change should be done after a working period. Because oil is hot in this condition and impurities are mixed with it the changing of oil will be done in best result and the oil will drain easily.

Schmierung

Um eine lange Lebensdauer zu gewährleisten muss der Schmierstoff richtig ausgewählt werden.

Für die richtige Ölauswahl müssen Drehzahl, Umgebungstemperatur, Belastungsart und Lebensdauer des Öls berücksichtigt werden. Die mitgelieferte Entlüftungsschraube ist vor Inbetriebnahme oder längeren Lagern gegen die Einfüllschraube auszutauschen, um einen Überdruck im Getriebe und damit eine Undichtigkeit des Getriebes zu vermeiden. Getriebe und Getriebemotoren sind bei Auslieferung betriebsfertig gefüllt.

Ohne besondere Bestellangaben werden die Getriebe grundsätzlich mit den auf der Seite 33 in der grau unterlegten Spalte angegebenen Schmierstoffen gefüllt. Bitte im Getriebe verwendetes Öl und menge von dem Namensschild ablesen. Die fußbefestigten Getriebe sind befüllt für Bauform und die flanschbefestigten Getriebe für Bauform M1. Für andere Bauformen sind die auf der nächsten Seite angegebenen Füllmengen zu beachten.

Ein Schmierstoffwechsel sollte alle 10.000 Betriebsstunden durchgeführt werden. Für synthetische Produkte verdoppeln sich diese Fristen. Bei extremen Betriebsbedingungen, z.B. hohe Luftfeuchtigkeit, aggressiver Umgebung und hohen Temperaturschwankungen sind kürzere Schmierstoffintervalle vorteilhaft. Es ist empfehlenswert, dem Schmierstoffwechsel mit einer gründlichen Reinigung des Getriebes zu verbinden. Synthetische und mineralische Schmierstoffe dürfen nicht miteinander vermischt werden. Das Ablassen des Öls soll unmittelbar nach dem Stillsetzen erfolgen, solange das Öl noch warm ist. In dieser Zustand ist das Öl mit den Schmutzpartikeln vermischt, so dass eine Entfernung des Altöls eine gute Reinigung garantiert.

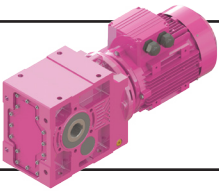

Genel Bilgiler General Information Einführung



M4 Montaj Pozisyonu için Genleşme Tankı / Expansion Tank for M4 Mounting Position / Ölausgleichsbehälter für M4 Bauform

Aşağıdaki teknik resimde gösterildiği gibi montaj pozisyonları **M4** (montaj pozisyonları syf.34) olan redüktörlerde düzgün bir yağlama sağlanabilmesi için yağ seviyesinin redüktörün üst dişlilerinin yağlanabileceği seviyede olması gerekmektedir. Buda düşük çevrim oranlı redüktörlerde köpürme ve genleşme nedeniyle havalandırma tapasından yağ atılmasına neden olabilmektedir.

Yılmaz redüktör; bunun önlenmesi için çevrim oranı (i) < 20 ve K47'den daha büyük olan bütün gövdelerde **M4** montaj pozisyonunda genleşme tankı kullanılmasını kesinlikle önermektedir. Önerilen genleşme tankı ölçüleri aşağıdaki tabloda gösterilmiştir.

Çevrim oranı (i) < 20 olup giriş motor devri 1800 d/d dan büyük olan bütün redüktörlerde **M4** montaj pozisyonunda genleşme tankı kullanılması redüktör büyüklüğüne bakılmaksızın önerilmektedir.

*As you can see at the technical drawing below, for gear units with **M4** (mounting positions p. 34) mounting position, oil level is very high for proper lubrication of upper pinion gear and this leads to oil leakage from venting plug, because of foaming and expansion of oil at geared motors with ratios below 20.*

*We ; Yılmaz Redüktör, strongly recommend using expansion tank for **M4** mounting position for gear units K57, K67, K77, K87 and K97 with total ratios (i) below 20, to prevent this. You can find the recommended dimensions of expansion tanks below.*

*If your gear units total ratio (i) is below 20 and input speed is higher than 1800 rpm we recommend using of expansion tank for all gear unit sizes for **M4** mounting position.*

Wie in der folgenden technischen Zeichnung dargestellt ist, sollte der Ölstand auf der gleichen Höhe der ersten Getriebestufe sein, um eine ausreichende Schmierung des oberen Zahnrads bei der **M4** Bauform (s. Seite 34) sicher zu stellen. Aufgrund dieses hohen Ölstands bildet sich Ölschaum aus, welcher aus der Entlüftungsschraube austritt.

Um das verhindern zu müssen, empfiehlt Yılmaz Redüktör bei allen K-Serie Getrieben ab Getriebebaugröße K57 mit niedrigen Übersetzungen (i<20) einen Ölausgleichsbehälter bei der **M4** Bauform einzusetzen. Die empfohlenen Dimensionen des Ölausgleichsbehälters sind in der unteren Tabelle angegeben.

Bei Getrieben mit Übersetzungen (i<20) und bei Motor-Eingangsdrehzahlen >1800 min⁻¹ empfiehlt Yılmaz Redüktör einen Ölausgleichsbehälter unabhängig von der Getriebebaugröße einzusetzen.

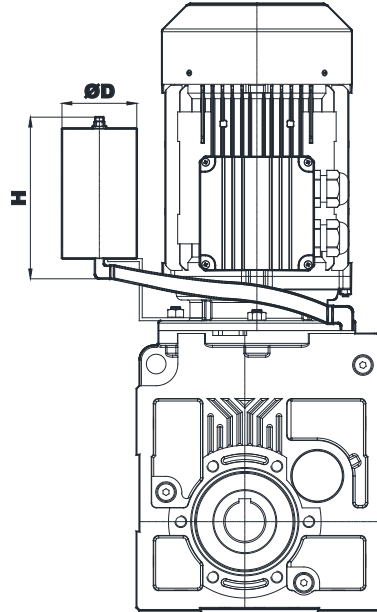

Gövde Büyüklüğü Housing Size Gehäusegröße	Genleşme Tankı Expansion Tank Ölausgleichsbehälter	D [mm]	H [mm]	Ağırlık Weight Gewicht [kg]
K57..	G1	100	150	4
K67.. , K77..	G2	150	250	5
K87.. , K97..	G3	180	400	9

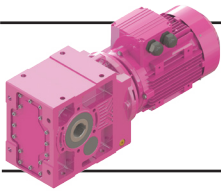

Genel Bilgiler

General Information

Einführung



Yağ Tipleri / Oil Types / Schmierstoffe

Yağ Cinsi Lubricant Art des Schmierers	DIN 51517-3	Çevre Sıcaklığı (°C) Ambient Temperature (°C) Umgebungstemperatur (°C)		ISO VG	Aral	Beyond Petroleum	Castrol	Klüber Lubrication	Mobil	Shell	Total
		Daldırma Yağlama Dip Lubrication Tauchschrmer.	Basınçlı Yağlama Forced Lubrication Druckschrmer.								
Mineral Yağlar Mineral Oil Mineralöl	CLP	0 ... +50	-	680	Degol BG 680	Energol GR-XP 680	Alpha SP 680	Klüberoil GEM 1-680 N	Mobilgear 600 XP 680	Omala S2 GX 680	Carter EP 680
		-5 ... +45	-	460	Degol BG 460	Energol GR-XP 460	Alpha SP 460	Klüberoil GEM 1-460 N	Mobilgear 600 XP 460	Omala S2 GX 460	Carter EP 460
		-10 ... +40	+15 ... +40	320	Degol BG 320	Energol GR-XP 320	Alpha SP 320	Klüberoil GEM 1-320 N	Mobilgear 600 XP 320	Omala S2 GX 320	Carter EP 320
		-15 ... +30	+10 ... +30	220	Degol BG 220	Energol GR-XP 220	Alpha SP 220	Klüberoil GEM 1-220 N	Mobilgear 600 XP 220	Omala S2 GX 220	Carter EP 220
		-20 ... +20	+5 ... +20	150	Degol BG 150	Energol GR-XP 150	Alpha SP 150	Klüberoil GEM 1-150 N	Mobilgear 600 XP 150	Omala S2 GX 150	Carter EP 150
		-25 ... +10	+3 ... +10	100	Degol BG 100	Energol GR-XP 100	Alpha SP 100	Klüberoil GEM 1-100 N	Mobilgear 600 XP 100	Omala S2 GX 100	Carter EP 100
Sentetik Yağlar Synthetic Oil Synthetisches Öl	CLP PG	-10 ... +60	-	680	Degol GS 680	Energol SG-XP 680	-	Klübersynth GH 6 -680	Mobil Glygoyle 680	Omala S4 WE 680	Carter SY 680
		-20 ... +50	-	460	Degol GS 460	Energol SG-XP 460	Aphasyn PG 460	Klübersynth GH 6 -460	Mobil Glygoyle 460	Omala S4 WE 460	Carter SY 460
		-25 ... +40	+5 ... +40	320	Degol GS 320	Energol SG-XP 320	Aphasyn PG 320	Klübersynth GH 6 -320	Mobil Glygoyle 320	Omala S4 WE 320	Carter SY 320
		-30 ... +30	0 ... +30	220	Degol GS 220	Energol SG-XP 220	Aphasyn PG 220	Klübersynth GH 6 -220	Mobil Glygoyle 30	Omala S4 WE 220	Carter SY 220
		-35 ... +20	-5 ... +20	150	Degol GS 150	Energol SG-XP 150	Aphasyn PG 150	Klübersynth GH 6 -150	Mobil Glygoyle 22	Omala S4 WE 150	Carter SY 150
		-40 ... +10	-8 ... +10	100	-	-	-	Klübersynth GH 6 -100	Mobil Glygoyle 100	-	-
	CLP HC	-10 ... +60	-	680	-	-	-	Klübersynth GEM 4-680 N	Mobil SHC Gear 680	Omala S4 GXV 680	Carter SH 680
		-20 ... +50	-	460	Degol PAS 460	Energol EP-XF 460	Alphasyn T 460	Klübersynth GEM 4-460 N	Mobil SHC Gear 460	Omala S4 GXV 460	Carter SH 460
		-30 ... +40	+5 ... +40	320	Degol PAS 320	Energol EP-XF 320	Alphasyn T 320	Klübersynth GEM 4-320 N	Mobil SHC Gear 320	Omala S4 GXV 320	Carter SH 320
		-40 ... +40	0 ... +30	220	Degol PAS 220	Energol EP-XF 220	Alphasyn T 220	Klübersynth GEM 4-220 N	Mobil SHC Gear 220	Omala S4 GXV 220	Carter SH 220
		-40 ... +40	-5 ... +20	150	Degol PAS 150	Energol EP-XF 150	Alphasyn T 150	Klübersynth GEM 4-150 N	Mobil SHC Gear 150	Omala S4 GXV 150	Carter SH 150
		-40 ... +40	-8 ... +10	100	-	-	-	Klübersynth GEM 4-100 N	Mobil SHC 627	Omala S4 GXV 100	-
Gıda Uyumlu Yağ Food Grade Oil Lebensmittelöl	CLP NSF H1	-30 ... +25	+5 ... +25	220	-	-	Optileb GT 220	Klüberoil 4 UH1-220 N	Mobil SHC Cibus 220	Cassida Fluid GL-220	Nevastane SL 220
Çevre Dostu Yağ Biodegradable Oil Biologisch abbaubares Öl	CLP E	-25 ... +40	+5 ... +40	320	-	-	Tribol BioTop 1418-320	Klübersynth GEM 2-320	-	-	Carter Bio 320
Mineral Gresler [-20 ... +120 °C Çalışma Sıcaklığı] Mineral Grease [-20 ... +120 °C Working Temperature] Mineral-Fett [-20 ... +120 °C Betriebstemperatur]					Aralub HL3	Energol LS 3	Speherol AP3	Centoplex 2 EP	Mobilux EP 3	Gadus S2 V100 3	Multis Complex EP 2
Sentetik Gresler [-30 ... +100 °C Çalışma Sıcaklığı] Synthetic Grease [-30 ... +100 °C Working Temperature] Synthetisches Fett [-30 ... +100 °C Betriebstemperatur]					-	Energol SY 2202	-	Petamo GHY 133 N	Mobiltemp SHC 100	Gadus S5 V100 2	Multis Complex SHD 220

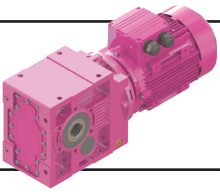

Genel Bilgiler

General Information

Einführung



Montaj Pozisyonları / Mounting Positions / Bauformen

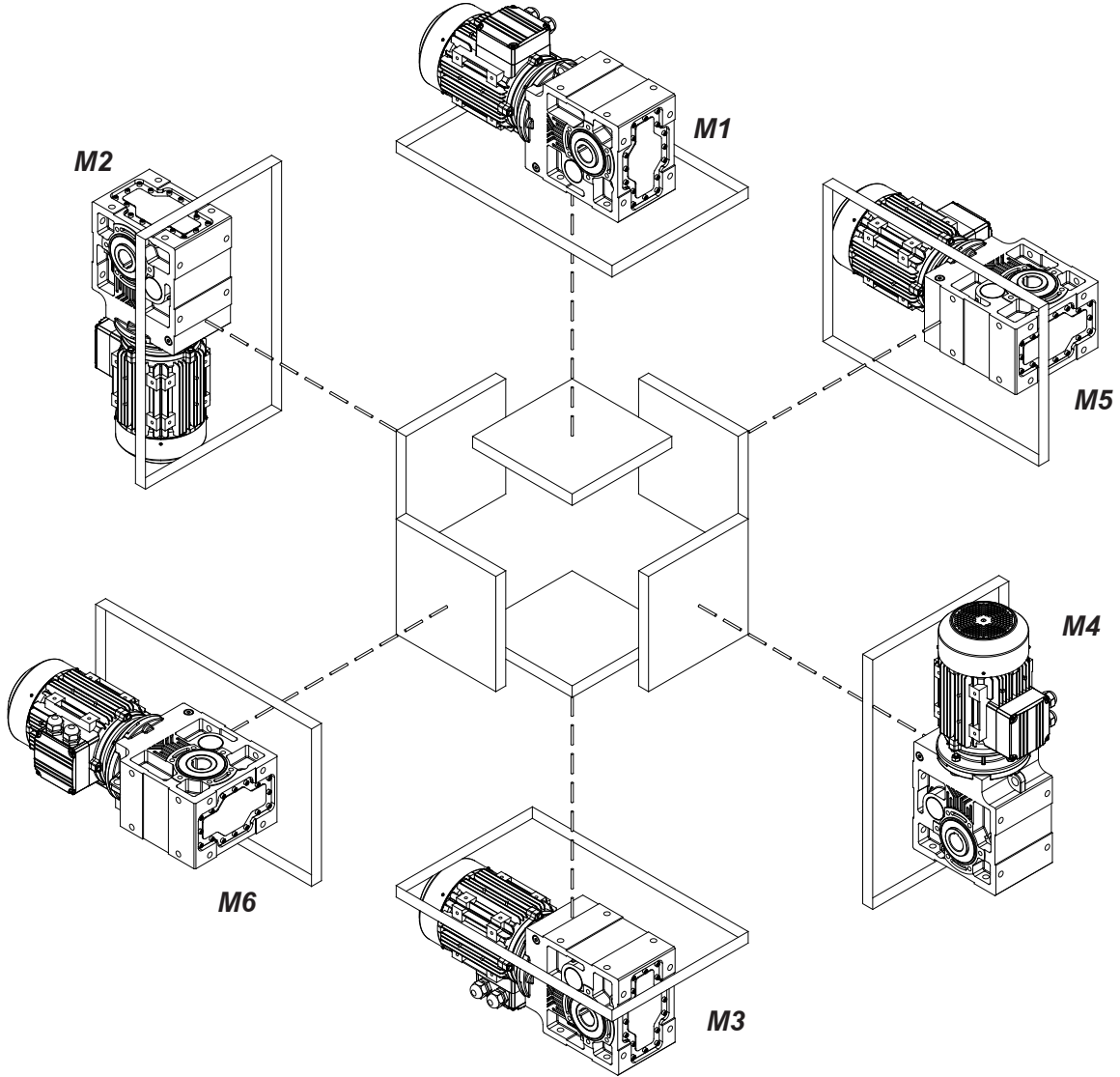

M1....M6 'ya kadar belirtilen montaj pozisyonları redüktörün duruş yönü referans alınarak belirlenmiştir. Montaj yüzeyleri bağlayıcı değildir.
Figured mounting positions of M1 to M6 are determined as reference of directional position of the gearbox. Mounting surfaces are not binding.
Dargestellte Montagepositionen M1 bis M6 wurden nach der Stehrichtung von Getriebe bestimmt. Montageoberflächen sind unverbindlich.

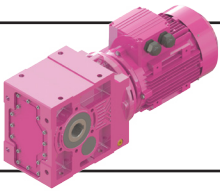

Genel Bilgiler

General Information

Einführung



K.00. - K.20. İki - Üç Kademeli Helisel-Konik Dişli Redüktörler Yağ Seviye Tapaları

K.00. - K.20. Two - Three Stage Helical-Bevel Geared Gearboxes Oil Level Plugs

K.00. - K.20. Zwei-Dreistufige Stirn-Kegelradgetriebe Ölverschlußschrauben

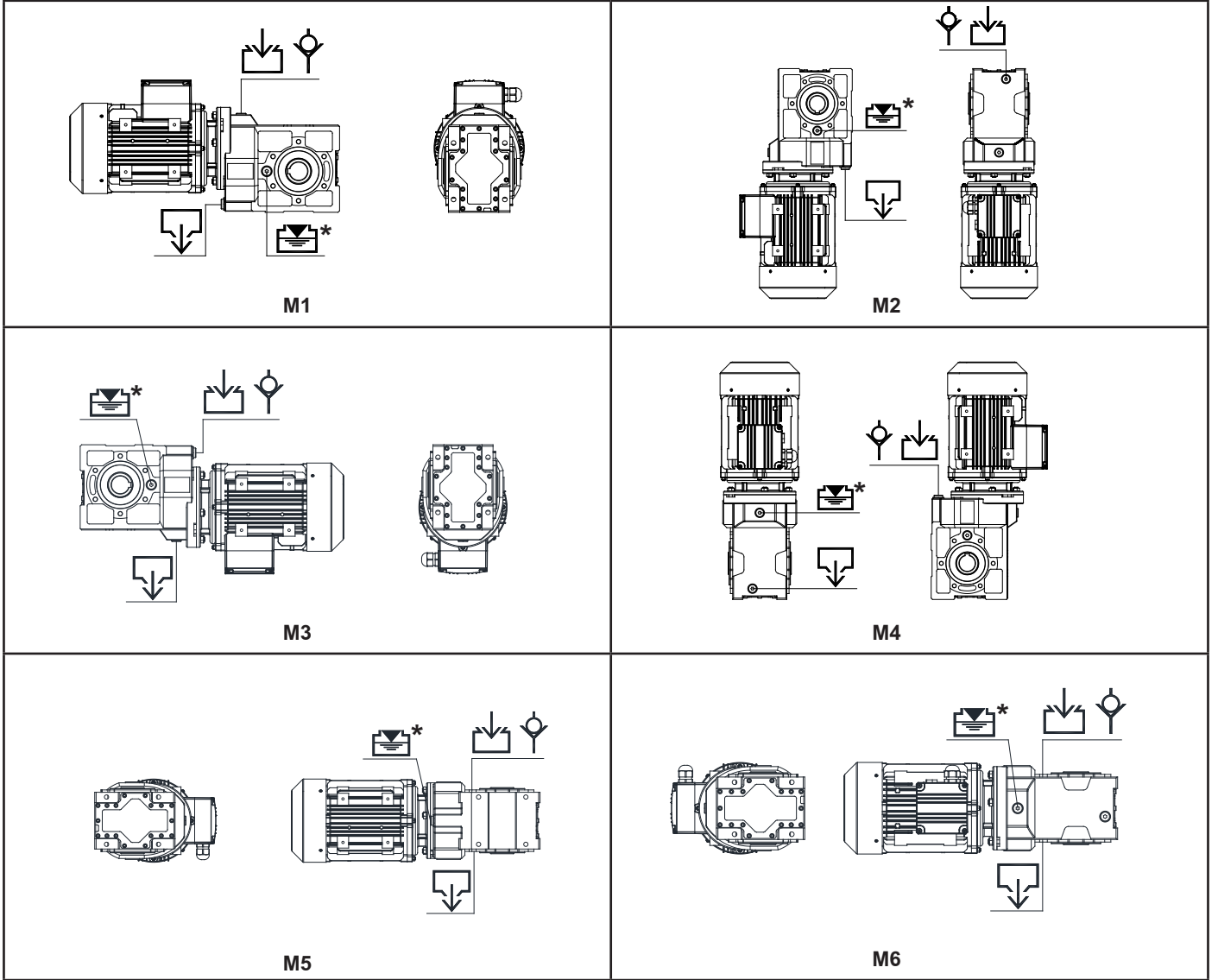

* : K002 ve K003'de bu tapa yoktur. Lütfen tablodaki yağ miktarına göre yağ koyunuz.

* : For K002 and K003 this plug doesn't exist. Please refer to oil quantities.

* : Bei K002 und K003 existiert diese Ölstands-schraube nicht. Bitte nach Ölmenge füllen.

Yağ Miktarları (lt) / Oil Quantities (lt) / Ölmengen (Liter)

Tip / Type / Typ	M1	M2	M3	M4	M5	M6
K.002	0,3	0,6	0,5	0,8	0,65	0,65
K.003	0,3	0,6	0,5	0,8	0,65	0,65
K.102	0,55	0,8	0,85	1,1	0,8	0,8
K.103	0,5	0,7	0,8	1,0	0,8	0,8
K.202	1,0	1,35	1,5	1,7	1,4	1,4
K.203	0,9	1,25	1,4	1,4	1,6	1,3

Semboller :

Symbols :

Symbole :

: Yağ boşaltma

: Drain plug

: Ölauslass

: Yağ doldurma

: Oil filling

: Ölfüllung

: Havalandırma

: Vent plug

: Entlüftungsschraube

: Yağ seviyesi

: Oil level

: Ölstand

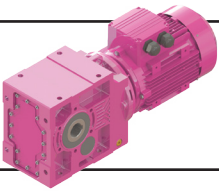

Genel Bilgiler

General Information

Einführung



K.273 - K.973 Üç Kademeli Helisel-Konik Dişli Redüktörler Yağ Seviye Tapaları
K.273 - K.973 Three Stage Helical-Bevel Geared Gearboxes Oil Level Plugs
K.273 - K.973 Dreistufig Stirn-Kegelradgetriebe Ölverschlußschrauben

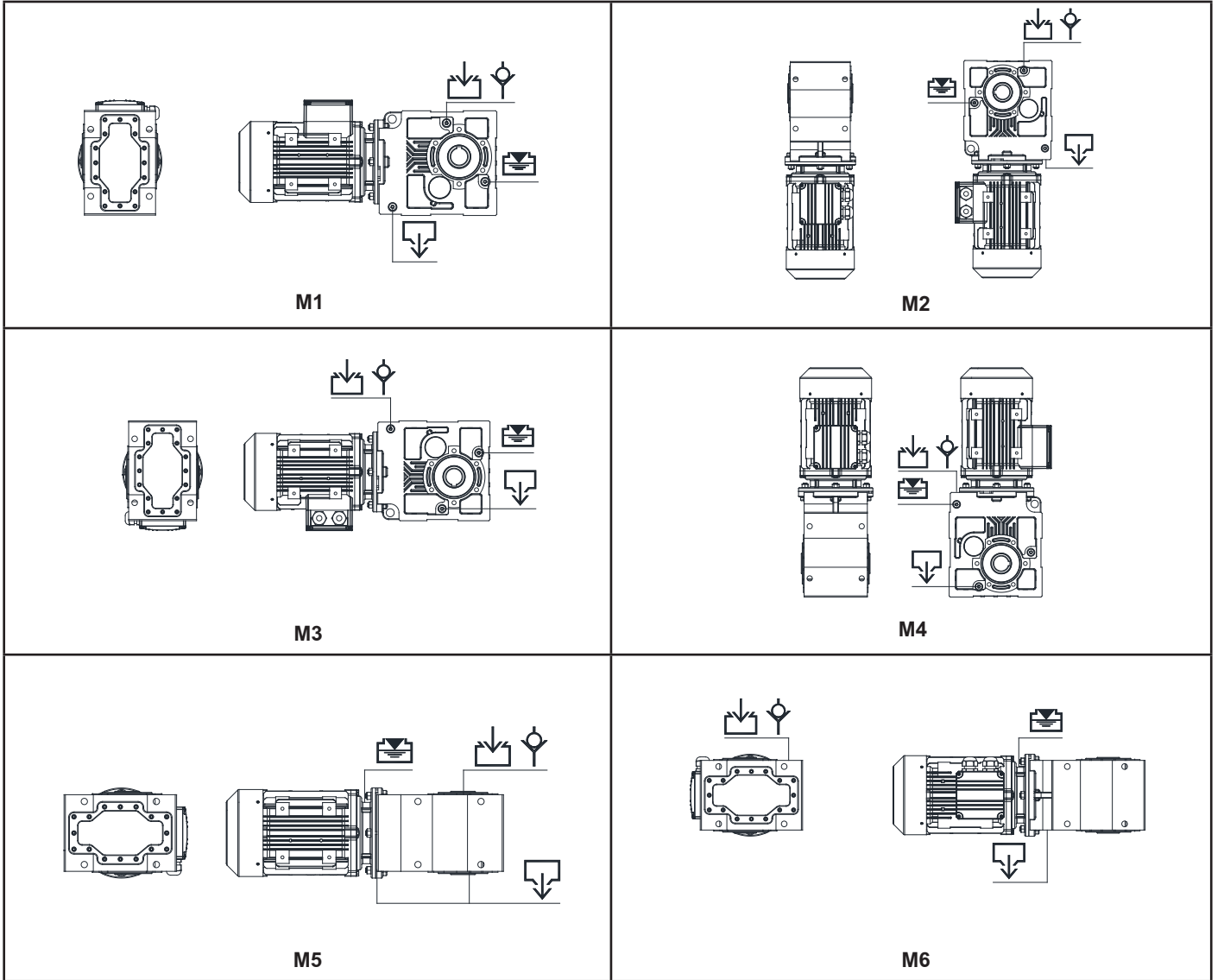

Yağ Miktarları (lt) / Oil Quantities (lt) / Ölmengen (Liter)

Tip / Type / Typ	M1	M2	M3	M4	M5	M6
K.273	0,8	1,8	2,2	2,3	1,4	1,5
K.283	1,2	2,4	2,5	2,9	1,9	1,9
K.373	1,4	3,3	3,4	4,0	1,9	2,2
K.473	2,7	5,9	6,5	7,8	4,0	4,5
K.573	4,1	9,0	9,7	11,5	5,5	6,6
K.673	8,7	16,3	18,0	22,5	11,7	13,2
K.773	13,0	28,0	30,0	35,0	18,0	20,0
K.873	28,0	50,0	46,0	63,0	45,0	36,0
K.973	47,0	85,0	85,0	117,0	77,0	64,0

Semboller :

Symbols :

Symbole :



: Yağ boşaltma

: Drain plug

: Ölauslass



: Yağ doldurma

: Oil filling

: Ölfüllung



: Havalandırma

: Vent plug

: Entlüftungsschraube



: Yağ seviyesi

: Oil level

: Ölstand

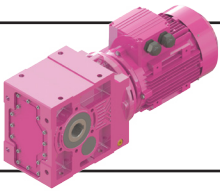

Genel Bilgiler

General Information

Einführung



K.374 - K.974 Dört Kademeli Helisel-Konik Dişli Redüktörler Yağ Seviye Tapaları
K.374 - K.974 Four Stage Reduction Helical-Bevel Geared Gearboxes Oil Level Plugs
K.374 - K.974 Vierstufig Stirn-Kegelradgetriebe Ölverschlußschrauben

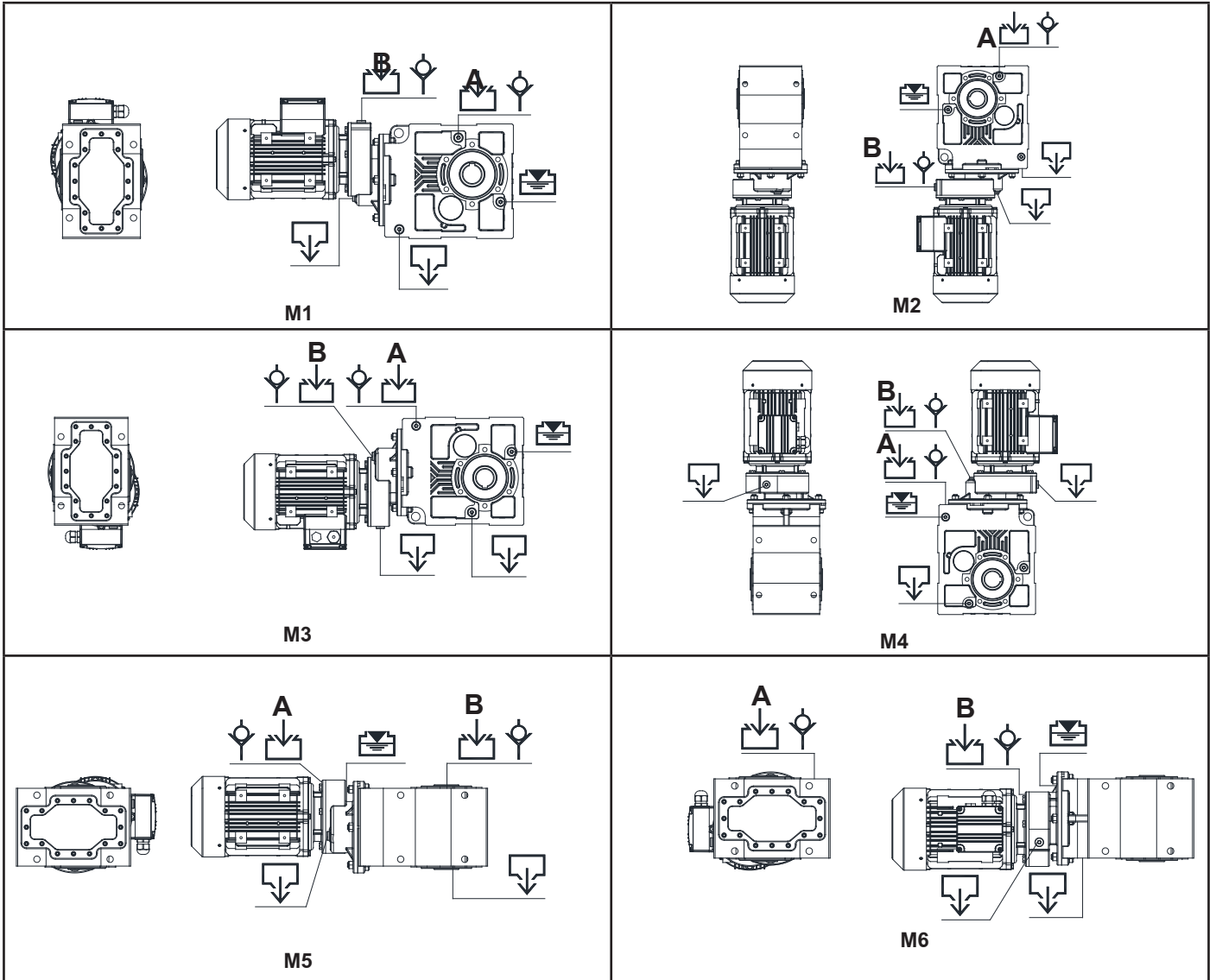

Yağ Miktarları (lt) / Oil Quantities (lt) / Ölmengen (Liter)

Tip / Type / Typ	M1 A / B	M2 A / B	M3 A / B	M4 A / B	M5 A / B	M6 A / B
K.284	1,2 / 0,20	2,4 / 0,20	2,5 / 0,20	2,9 / 0,20	1,9 / 0,20	1,9 / 0,20
K.374	1,4 / 0,25	3,3 / 0,25	3,4 / 0,25	4,0 / 0,25	1,9 / 0,25	2,2 / 0,25
K.474	2,7 / 0,4	5,9 / 0,4	6,5 / 0,4	7,8 / 0,4	4,0 / 0,4	4,5 / 0,4
K.574	4,1 / 0,5	9,0 / 0,5	9,7 / 0,5	11,5 / 0,5	5,5 / 0,5	6,6 / 0,5
K.674	8,7 / 0,9	16,3 / 0,9	18,0 / 0,9	22,5 / 0,9	11,7 / 0,9	13,2 / 0,9
K.774	13,0 / 1,0	28,0 / 1,0	30,0 / 1,0	35,0 / 1,0	18,0 / 1,0	20,0 / 1,0
K.874	28,0 / 2,2	50,0 / 2,2	46,0 / 2,2	63,0 / 2,2	45,0 / 2,2	36,0 / 2,2
K.974	47,0 / 7,0	85,0 / 7,0	85,0 / 7,0	117,0 / 7,0	77,0 / 7,0	64,0 / 7,0

Semboller :
Symbols :
Symbole :

: Yağ boşaltma
: Drain plug
: Ölauslass

: Yağ doldurma
: Oil filling
: Ölfüllung

: Havalandırma
: Vent plug
: Entlüftungsschraube

: Yağ seviyesi
: Oil level
: Ölstand

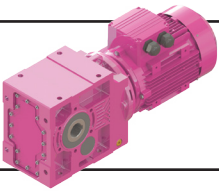

Genel Bilgiler

General Information

Einführung



K.27. - K.97. Beş-Altı Kademeli Helisel-Konik Dişli Redüktörler Yağ Seviye Tapaları
K.27. - K.97. Five-Six Stage Helical-Bevel Geared Gearboxes Oil Level Plugs
K.27. - K.97. Fünf-Sechststufig Stirn-Kegelradgetriebe Ölverschlußschrauben

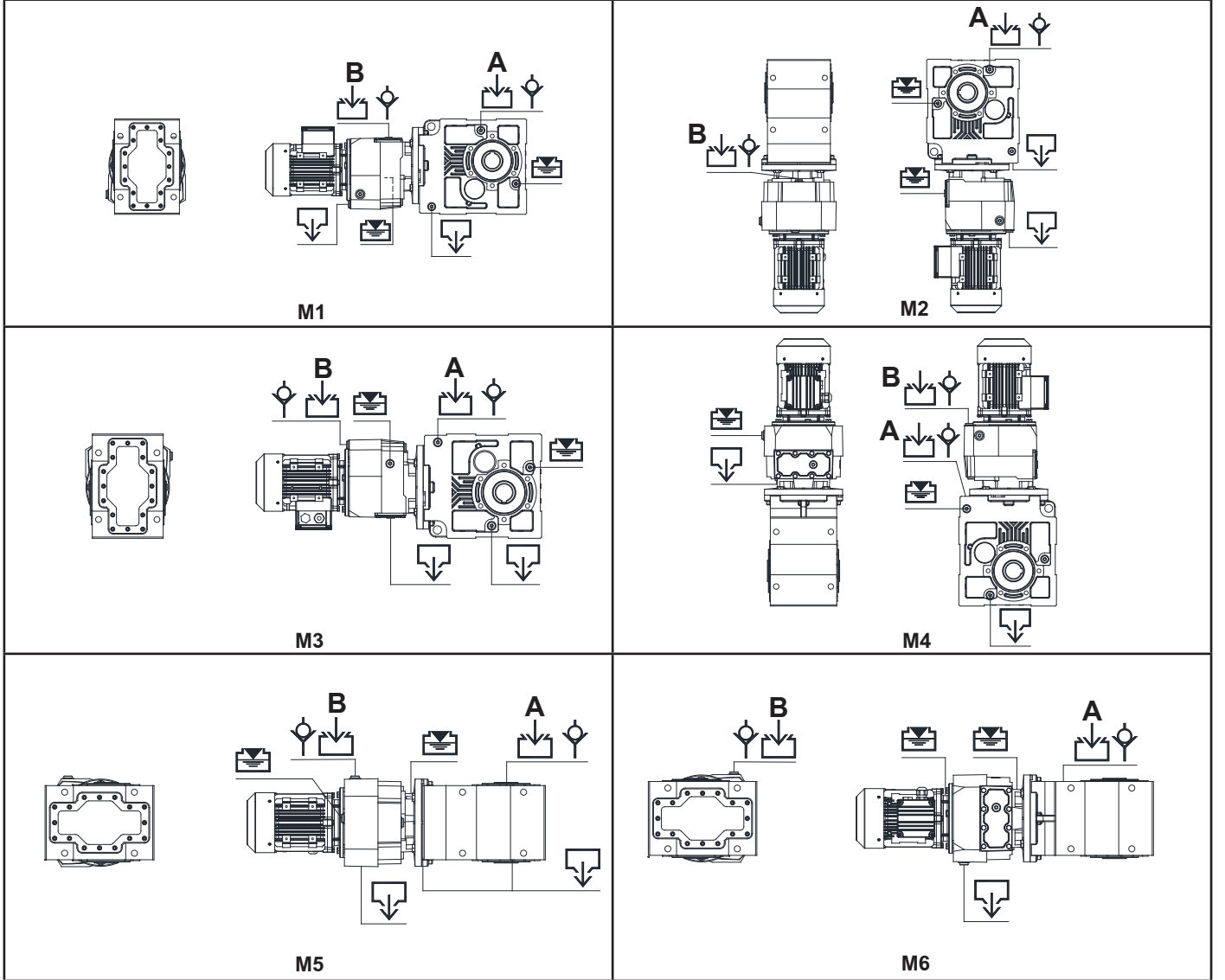



Yağ Miktarları (lt.) / Oil Quantities. (lt) / Ölmengen (Liter)

Tip / Type / Typ	M1 A / B	M2 A / B	M3 A / B	M4 A / B	M5 A / B	M6 A / B
K.275-276	0,8 / 0,4	1,8 / 0,6	2,2 / 0,5	2,3 / 0,6	1,4 / 0,5	1,5 / 0,5
K.285-286	1,2 / 0,54	2,4 / 0,8	2,5 / 0,6	2,9 / 0,8	1,9 / 0,6	1,9 / 0,6
K.375-376	1,4 / 0,65	3,3 / 0,95	3,4 / 0,7	4,0 / 0,95	1,9 / 0,7	2,2 / 0,7
K.475-476	2,7 / 1,2	5,9 / 2,1	6,5 / 2,0	7,8 / 2,1	4,0 / 1,4	4,5 / 1,4
K.575-576	4,1 / 1,2	9,0 / 2,1	9,7 / 2,0	11,5 / 2,1	5,5 / 1,4	6,6 / 1,4
K.675-676	8,7 / 2,0	16,3 / 3,4	18,0 / 3,1	22,5 / 3,4	11,7 / 2,8	13,2 / 2,8
K.775-776	13,0 / 2,0	28,0 / 3,4	30,0 / 3,1	35,0 / 3,4	18,0 / 2,8	20,0 / 2,8
K.875-876	28,0 / 2,0	50,0 / 3,4	46,0 / 3,1	63,0 / 3,4	45,0 / 2,8	36,0 / 2,8
K.975-976	47,0 / 4,0	85,0 / 7,6	85,0 / 7,0	117,0 / 7,6	77,0 / 5,0	64,0 / 5,0

Semboller :
Symbols :
Symbole :

 : Yağ boşaltma
: Drain plug
: Ölauslass

 : Yağ doldurma
: Oil filling
: Ölfüllung

 : Havalandırma
: Vent plug
: Entlüftungsschraube

 : Yağ seviyesi
: Oil level
: Ölstand

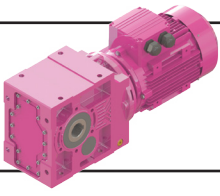

Genel Bilgiler

General Information

Einführung



MOTORLAR

AC Motorlar

a- Genel Özellikler:

Basit konstrüksiyonlu, bakım gerektirmez, güvenilirliği yüksek ve uygun fiyatlı olmaları nedeni ile trifaze asenkron motorlar en çok kullanılan motor cinsidir. Bu motorların çalışma karakteristikleri moment-hız eğrisi ile belirlenir. Aşağıda bu karakteristik eğrisine bir örnek verilmiştir.

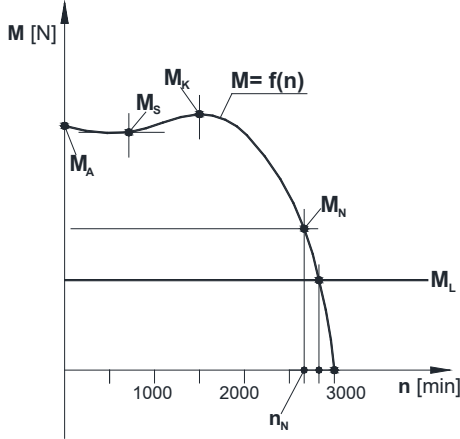

Motorun her start yapılmasında bu eğriye uygun hareket eder ve yük momenti M_L ile bu eğrinin çakıştığı nokta, motorun çalışma anındaki moment ve devirini verir.

Statorun manyetik alanı senkron hızla n_s döner. Kutuplar arasındaki faz kayması 3 fazlı motorlarda 120° 'dir.

$$n_s = 120 \times \frac{f}{p_s}$$

f.....: şebeke frekansı [Hz]
p_s.....: statorun kutup sayısı

Rotorun değişken manyetik alanı rotorun statorun manyetik alanının dönüşü yönünde dönmeye başlamasını sağlar. Rotor bu hareketinde statorun manyetik alanını takip eder ama hiçbir zaman yakalayamaz. Rotor statorun manyetik alanının hızından yavaş döner. Rotorun bu hızına baz hız n_N denir. Yükün azalması rotorun hızının artmasını sağlar, aynı zamanda sapma azalır. Sapma aşağıdaki gibi belirlenmiştir:

$$s = \frac{n_s - n_N}{n_s} \times 100$$

Sapmanın miktarına göre motorun nominal değerlerinde şu farklılıklar olabilir.

Sapma s: $\pm 20\%$
Kalkış Akımı.....: $\pm 20\%$
Kalkış Momenti.....: $-15/+25\%$
Kütle Atalet Momenti.....: $\pm 10\%$
Verim (37 kW'a kadar).....: $-0,15 (1-\eta)$

MOTORS

AC Motors

a- General Specifications:

On account of its simple and maintenance free construction, good reliability and price, the three phase squirrel cage motor is one of the most frequently employed electric motors. The run up behavior of a three phase squirrel cage motor is described by the torque-speed characteristic curve. An example is shown below.

M_A : Start momenti / Starting torque / Anlaufmoment

M_S : Demeraj momenti / Pull-up torque / Anziehungsmoment

M_K : Frenleme momenti / Pull-out torque / Bremsmoment

M_N : Motorun ilettiği moment / Motor rated torque / Treibmoment

M_L : Yük momenti / Load torque / Lastmoment

The motor follows this torque characteristics up to its stable operating point every time, when it is switched on. Operating point is that point, where the moment speed curve intersects with load torque M_L line.

The magnetic field in the stator rotates at a synchronous speed n_s . Phase shift of each pole is 120° at 3 phase motors.

$$n_s = 120 \times \frac{f}{p_s}$$

f.....: supply frequency [Hz]
p_s.....: number of stator poles

Because of the alternating magnetic field in the rotor, the rotor starts running in the same direction of the stator flux and tries to catch up with the rotating flux. The rotor never catches up the stator field. The rotor runs slower than the speed of the stator field. This speed is called the base speed n_N .

A decrease in load will cause the rotor to speed up or decrease slip. The slip is defined as follows:

$$s = \frac{n_s - n_N}{n_s} \times 100$$

According to the slip, the nominal values of the electric motor can alter as follows:

Slip s: $\pm 20\%$
Starting current: $\pm 20\%$
Starting torque: $-15/+25\%$
Moment of inertia.....: $\pm 10\%$
Efficiency (up to 37 kW).....: $-0,15 (1-\eta)$

MOTOREN

Drehstrommotoren:

a- Allgemeine Eigenschaften

Wegen die wartungsarme und leichte Konstruktion, hohe Sicherheit bei Nutzung und günstige Preise werden die asynchrone Drehstrommotoren am meisten benutzt. Motoranlaufverhalten wird mit Moment-Drehzahl-Kurve charakterisiert. Ein Beispiel ist unten angegeben.

Der Drehstrommotor läuft diese Kurve bei jedem Anlauf, bis dem stabilen Betriebspunkt erreicht wird. Betriebspunkt ist der Zustand, bei dem die Moment-Drehzahl-Kurve sich mit der Linie von erforderlichen Moment M_L schneidet.

Magnetisches Feld von Stator dreht sich mit synchroner Geschwindigkeit n_s . Phasenverschiebung von den Polen ist 120° bei 3phasigen Drehstrommotoren.

$$n_s = 120 \times \frac{f}{p_s}$$

f.....: Frequenz der Spannung [Hz]
p_s.....: Anzahl der Polen von Stator

Durch das magnetische Wechselfeld in den Rotor, beginnt der Rotor sich in der gleichen Richtung des Statorflusses zu drehen und versucht diese Bewegung aufzuholen. Der Rotor kann das Statorfeld nie aufholen. Die Rotorgeschwindigkeit nennt man Basisgeschwindigkeit n_N . Eine Abnahme der Belastung bewirkt, dass der Rotor sich beschleunigt und der Schlupf sich verringert. Der Schlupf wird wie folgt definiert:

$$s = \frac{n_s - n_N}{n_s} \times 100$$

Für die nominale Werte der Drehstrommotoren sind folgende Abweichungen zulässig:

Schlupf s: $\pm 20\%$
Anzugsstrom: $\pm 20\%$
Anzugsmoment: $-15/+25\%$
Massenträgheitsmoment: $\pm 10\%$
Wirkungsgrad (bis 37 kW).....: $-0,15 (1-\eta)$

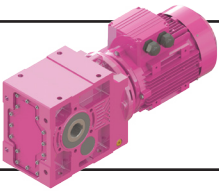

Genel Bilgiler

General Information

Einführung



b- Çalışma Türleri

Katalogta verilen tüm redüktörlerin motorları S1 çalışma türüne uygun verilmektedir. Diğer çalışma türleri aşağıdaki tabloda gösterilmiştir.

b-Modes of Operation

All motors of the catalogue have been laid out for duty S1 (continuous operation). Other duty types are given on the following table.

b-Betriebsarten

Die im Katalog angeführten Motoren sind für Betriebsart S1 (Dauerbetrieb) ausgelegt. Andere Betriebsarten sind unten angegeben.

Çalışma Türü Operation Betriebsarten	Açıklama Explanation Erläuterung	Yük Grafiği Load Graphic Lastverläufe
S1	Sabit yükte sürekli çalışma Continuous operation under constant load Dauerbetrieb mit konstanter Belastung	
S2	Sabit yükte kısa süreli çalışma Short-time duty under constant load Kurzbetrieb mit konstanter Belastung	
S3	Yolvermede sıcaklık artımı olmadan periyodik çalışma Periodic duty without influence of start-up on temperature Aussetzbetrieb ohne Einfluß des Anlaufens auf die Temperatur	
S4	Yolvermede sıcaklık artımı olan periyodik çalışma Periodic duty with influence of start up on temperature Aussetzbetrieb mit Einfluß des Anlaufens auf die Temperatur	
S5	Yolvermede ve frenlemede sıcaklık artımlı periyodik çalışma Periodic duty with influence of startup and braking on temp. Aussetzbetrieb mit Einfluß des Anlaufens / Bremsung auf die Temp.	
S6	Sürekli orta darbeleri çalışma Continuous operation with intermittent loading Durchlaufbetrieb mit Aussetzungsbelastung	
S7	Elektriksel frenlemeli sürekli orta darbeleri çalışma Continuous operation with intermittent loading and braking Ununterbrochener Betrieb mit Anlauf und Bremsung	
S8	Devir ve yük değişimli sürekli çalışma Continuous operation duty type with related load-speed changes Ununterbrochener periodischer Betrieb mit Drehzahländerung	

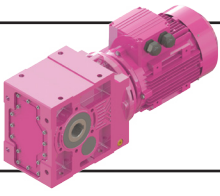

Genel Bilgiler

General Information

Einführung



c- Koruma Sınıfı:

Yılmaz Redüktörde standart olarak IP54 (IEC 34-5) koruma sınıfı motorlar kullanılmaktadır. Diğer koruma sınıfları istendiğinde firmamıza danışınız.

d- İzolasyon Sınıfı:

Yılmaz Redüktörde kullanılan standart izolasyon sınıfı F (IEC 317-8) dir. İstek üzerine H sınıfı yapılabilmektedir.

e- Verim Sınıfları:

Üç fazlı az gerilim asenkron motorların verim sınıfı ölçümü IEC 60034-2-1:2007 normu ile belirlenmiştir. Yeni IE verim sınıfı 0,75 kW'tan 375 kW'a kadar güç aralığında çalışan AC motorlar için geçerlidir. EFF verim sınıfından farklı olarak IE verim sınıfı 6 kutup sayılı motorlar içinde kullanılabilir. Aşağıda verim sınıfları sıralanmıştır. Bölgeler dışında verim sınıfı zorunlulukları ülkelere göre farklılık gösterebilir. Lütfen firmamıza danışınız. Başka ürünlere entegre olmuş ve bu nedenle motorun veriminin bağımsız belirlenmediği sistemlerde (redüktör pompa gibi) verim sınıflandırması geçerli değildir.

c- Protection Class:

Yılmaz Redüktör uses IP54 (IEC 34-5) protection class electric motors for standard products. If different kind of protection class is requested please contact us.

d- Insulation Class:

Yılmaz Redüktör uses F (IEC 317-8) insulation class electric motors for standard products. H insulation class is available upon request.

e- Efficiency Classes:

The method for measuring the efficiency of low voltage three-phase asynchronous motors was revised with the new IEC 60034-2-1:2007 standard. The new IE classes is valid for AC Motors in power range from 0,75 to 375 kW. Unlike the EFF classes IE classes can be used for 6-pole AC motors. Bellow is the table of efficiency classes. The instructions for efficiency classes can differ from country to country. Please contact with us for more information. For the motors, which are fully integrated into a product (for example gear, pump) so their energy efficiency can not be recognized independently, the requirements of efficiency are not valid in Europe.

c- Schutzarten:

Yılmaz Redüktör Getriebemotoren werden serienmäßig mit Schutzart IP54 (IEC34-5) ausgeführt. Für andere Schutzarten bitte rückfragen.

d- Isolationsklasse:

Yılmaz Redüktör Getriebemotoren werden serienmäßig in Wärmeklasse F (IEC317-8) ausgeführt. H Wärmeklasse ist möglich auf Kundenwunsch.

e- Energieeffizienzklassen:

Die Methode für Messung die Effizienz von drei phasigen gering Spannung Asynchronmotoren hat neu mit IEC 60034-2-1:2007 Norm festgestellt. Die neue IE-Klassen gelten für alle Drehstrommotoren im Leistungsbereich von 0,75 bis 375 kW. Anders als EFF-Klassen die IE-Klassen können auch für 6-polige Drehstrommotoren verwendet werden. Unten steht die Tabelle der Effizienzklassen. Die Richtlinien für Effizienzklassen können sich je nach dem Land unterscheiden. Bitte mit unserem Firma Kontakt aufnehmen. Für die Motoren, die vollständig in ein Produkt (zum Beispiel Getriebe, Pumpe) eingebaut sind und deren Energieeffizienz nicht unabhängig von diesem Produkt erfasst werden kann, gelten in Europa die Anforderungen der Effizienzklassen nicht.

Verim Sınıfları Efficiency Classes Energieeffizienzklassen			4 Kutuplu Motor Verim Değeri Hesabı Calculating Efficiency Values of Motors with 4 Poles Berechnung der Wirkungsgrade von Elektromotoren mit 4 Polen	
IE1	EFF 2	Standart Verim Standart Efficiency Standarte Energieeffizienz	A=0,5234 B=-5,0499 C=17,4180 D=74,3171	$\eta_{Mn} = A \times [\log_{10}(P_L)] + B \times [\log_{10}(P_L)]^2 + C \times \log_{10}(P_L) + D$ <p>P_L :Anma Yüğü [kW] / Nominal Load [kW] / Nennlast [kW]</p> <p>η_{Mn} :Nominal verim / Nominal Efficiency [kW] / Sollwirkungsgrad</p>
IE2	EFF 1	Yüksek Verim High Efficiency Hohe Energieeffizienz	A=0,0278 B=-1,9247 C=10,4395 D=80,9761	
IE3	-	Premium Verim Premium Efficiency Premium Energieeffizienz	A=0,0773 B=-1,8951 C=9,2984 D=83,7025	
IE4	-	Süper Premium Verim Super Premium Efficiency Super Premium Energieeffizienz	-	

4 Kutuplu Motor Verim Değerleri Efficiency Values of Motor with 4 poles Sollwirkungsgrad des Motors mit 4 Polen	Anma Yüğü [kW] Nominal Load [kW] Nennlast [kW]	Verim Sınıfı / Efficiency Class / Energieeffizienzklassen		
		IE1	IE2	IE3
	0,75	72,1 %	79,6 %	82,5 %
	1,5	77,2 %	82,8 %	85,3 %
	3	81,5 %	85,5 %	87,7 %
	7,5	86 %	88,7 %	90,4 %
	15	88,7 %	90,6 %	92,1 %
	22	89,9 %	91,6 %	93 %
	37	91,2 %	92,7 %	93,9 %
	45	91,7 %	93,1 %	94,2 %
	75	92,7 %	94 %	95 %
	90	93 %	94,2 %	95,2 %
	330	94 %	95,1 %	96 %

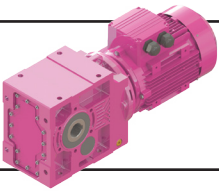

Genel Bilgiler General Information Einführung



f- AC Frekans Invertörler

Doğru Akımı (DC), alternatif akıma (AC) çeviren elektronik çeviricilere invertör denilmektedir. AC motorlar için elektronik hız kontrol cihazları genellikle AC giriş akımını doğrultucu diyotlarla DC akıma çevirir ve daha sonra çevirici diyotlar vasıtasıyla bu akımı tekrar AC akıma çevirir. Doğrultucu diyotlar ile çevirici diyotlar arasındaki bağlantı DC-bağ olarak tanımlanmaktadır. DC kontrol cihazının (genellikle invertör olarak isimlendirilir) elektriksel blok şeması aşağıda verilmiştir.

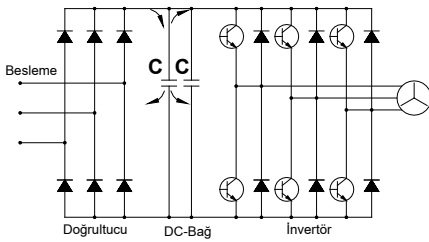

Tam dalga doğrultucuları besleyen üç faz besleme akımı DC-bağ kapasitörlerine iletilir. Kapasitörler voltajdaki dalgalanmaları azaltır ve kısa süreli ağıdaki akım kesintilerinde enerji sağlar. Kapasitörlerdeki voltaj kontrolsüzdür ve gelen AC akımın pik akım değerlerine bağlıdır. DC akım tekrar AC akıma, Puls genişliği modülasyonu (PWM) kullanılarak çevrilir. İstenen dalga formu, sabit bir frekansta (Puls frekansında), çıkış transistörlerinin (İzole edilmiş geçit Bipolar transistörleri; IGBT'ler) açılıp kapatılması ile oluşturulur. IGBT'lerin açma kapama zamanlarının değişimi ile istenen akım oluşturulabilir. Çıkış voltajı bir seri kare dalga pulslardır ve motor sargılarının indüktansı ile sinusoidal bir motor akımı oluşur. Puls genişliği modülasyonu aşağıda gösterilmiştir.

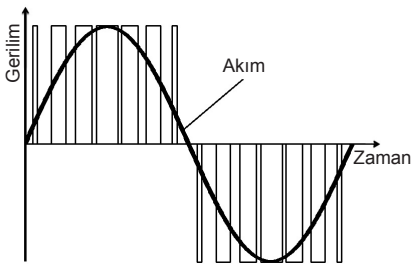

f- AC Frequency Inverters

An electronic converter is a device which converts Direct Current (DC) to Alternating Current (AC) is known as an inverter. Electronic speed controllers for AC motors usually convert the AC supply to DC using a rectifier, and then convert it back to a variable frequency, variable voltage AC supply using an inverter bridge. The connection between the rectifier and inverter is called the DC link. The block diagram of a speed controller (often called an inverter) is shown below.

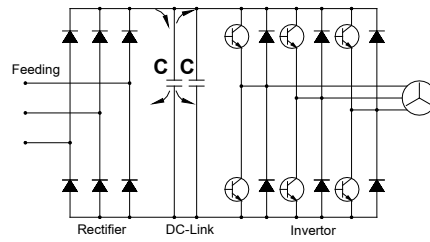

The three phase supply is fed into a full wave rectifier which supplies the DC link capacitors. The capacitors reduce the voltage ripple (especially on single supplies) and supply energy for short mains breaks. The voltage on the capacitors is uncontrolled and depends on the peak AC supply voltage. The DC voltage is converted back to AC using Pulse Width Modulation (PWM). The desired waveform is built up by switching the output transistors (Insulated Gate Bipolar Transistors; IGBTs) on and off at a fixed frequency (the switching frequency). By varying the on and off time of the IGBTs the desired current can be generated. The output voltage is still a series of square wave pulses and the inductance of the motor windings results in a sinusoidal motor current. Pulse Width Modulation is shown in the figure below.

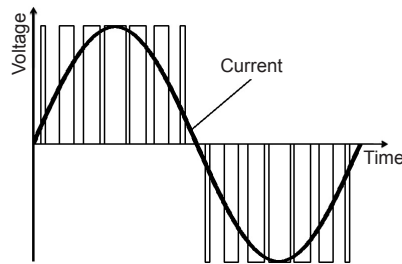

f- AC Frequenz Umrichter

Ein elektronischer Wandler, der den Gleichstrom (DC) in Wechselstrom (AC) umwandelt, wird als Umrichter bezeichnet. Ein Frequenzumrichter benutzt einen ungesteuerten Eingangsgleichrichter, um die Netzspannung in Gleichspannung umzuwandeln. Diese wird dann in den Zwischenkreiskondensatoren gespeichert. An diesem Gleichspannungszwischenkreis ist ein Wechselrichter angeschlossen. Dieser Wechselrichter erzeugt am Ausgang eine variable Frequenz und eine variable Spannung. Der Anschluss zwischen dem Gleichrichter und dem Wechselrichter nennt man Gleichstromverbindung. Das Blockschaltbild von diesem System wurde unten dargestellt:

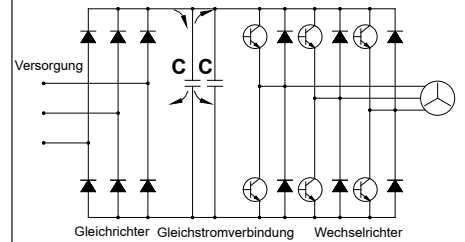

Auch bei dreiphasiger Versorgung wird die gleichrichtete Netzspannung den Zwischenkreiskondensatoren zugeführt. Die Kondensatoren reduzieren die Oberwelligkeit der Spannung (was besonders bei einphasiger Versorgung entscheidend ist) und liefern Energie, die kurze Unterbrechungen der Netzstromversorgung ermöglicht. Die Spannung der Kondensatoren ist vom Spitzenwert der Wechselspannung abhängig. Die Gleichspannung wird im Wechselrichter durch Pulsweitenmodulation (PWM) in Wechselspannung umgewandelt. Die gewünschte Wellenform wird durch Ein- und Ausschalten der Ausgangstransistoren (IGBT's Isolierte Gate Bipolar Transistoren) mit einer festen Frequenz (der Pulsfrequenz) erzeugt. Der gewünschte Strom kann durch die Variation der Ein- und Ausschaltzeit der Ausgangstransistoren generiert werden. Die Ausgangsspannung ist dadurch eine Reihe von Spannungsimpulsen, die in Verbindung mit der Induktivität der Motorspulen zu einem sinusförmigen Motorstrom führt. Die Pulsweitenmodulation wird wie folgt dargestellt

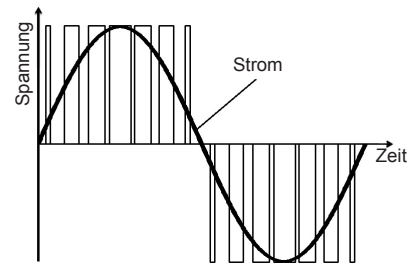

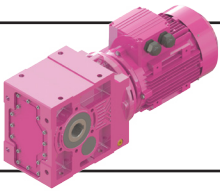

Genel Bilgiler

General Information

Einführung



DC MOTORLAR

a- Genel Özellikler

DC motorlar, elektronik parçalardaki gelişmeler nedeni ile yeni uygulama alanları bulmuştur. Daha önce çok pahalı olan ve ekonomik olmayan kontrol sistemlerinin yerini ucuz ve kompakt güç kontrol üniteleri almıştır. Yol vermenin kontrol altına alınabildiği, tork ve akım izlenebilirliği, aşırı yüklenmeye karşı elektronik koruma sağlanabilmesi ve daha birçok pahalı olmayan uygulamalar DC motorlarını cazip kılmaya başlamıştır.

b- DC Motorların Çalışma İlkeleri

DC motorlar için DC çıkış veren bir doğrultucuya ihtiyaç vardır. Motor armatür sargıları, alan sargıları, komutasyon sargıları ve kompanse sargılar olmak üzere rotorda ve statorda bulunan sargılardan oluşur. Rotora voltaj ve akım karbon fırçalar ve komutator sargılarla ulaştırılır. Bu karbon fırçalar aşındığından DC motorlar belirli periyotlarla bakıma alınmalıdır. İyi kontrol edilebilir özelliklerinden dolayı DC motorlar otomasyon teknolojisinde sıkça kullanılmaktadır.

c- DC Motor Çeşitleri

Temel olarak Şönt (Shunt) ve seri sargılı DC motorlar bulunmaktadır. Bu sargıların çeşidine göre moment eğrisi değişmektedir.

d- DC Motorlarda Hız Kontrolü

Bu motorlarda devir değişimi DC voltajın değiştirilmesi ile yapılır. Şönt sarımlı DC motorların sıfır yük ile maksimum yük arasındaki davranışı AC motorlara benzer. Devir artan yükte beraber düşer. Bu devir farkı ufak güçlü motorlarda büyük, büyük güçlü motorlarda ise ufaktır. Fakat bu hız farkı DC doğrultucu cihazda armatür voltajı ($I \times R$) ile oynanarak kompanse edilebilir. Hassas hız kontrol gereksinimi olduğunda, tako jeneratörler kullanılabilir. DC motorların gücü aşağıdaki formülden hesaplanır;

$$P_g = U \times I = \frac{P_c}{\eta}$$

P_g : Giriş gücü W
 P_c : Çıkış gücü W
 U : Armatür gerilimi V
 I : Armatür akımı A
 η : Motor verimi

DC MOTORS

a- General Specifications of DC Motors

DC drive systems have found new possible applications with the development of the electronic components sector. What was previously extremely expensive and in some cases not economically feasible is nowadays realized by miniaturised power converter technology. Additional functions such as guided startup after a predetermined time, torque and current monitoring with electronic protection against overloading, and many inexpensive special applications have made DC drive systems more attractive.

b- Operating principles of the DC Motors

The DC motor requires, a converter with DC output. The motor includes windings, such as armature, field, commutation and compensation windings, which are arranged in the stator as well as on rotor. Voltage and current are supplied to the rotor via the carbon brushes and the commutator. The carbon brushes are wearing parts therefore a DC motor requires maintenance at service intervals. While its good control properties, the DC motor is an essential item in automation technology.

c- Types of DC Motors

Depending on the wiring of the exciting winding or field winding, two basically different variants are regards torque speed characteristics may be distinguished.

d- Speed Control of DC motors

In DC motors the speed is adjusted by altering the DC voltage. DC shunt wounded motors behave similar to three phase induction motors between no load operation and maximum load. The speed drops with increasing loading of the motor. This difference is greater in small motors and smaller in larger motors. The speed difference can be compensated in the DC converter device by adjusting ($I \times R$). If great control accuracy is required, a speed control with measurement of the actual values by a tachogenerator can be used. The power of DC motor;

$$P_g = U \times I = \frac{P_c}{\eta}$$

P_g : Input Power W
 P_c : Output Power W
 U : Armature Voltage V
 I : Armature Current A
 η : Motor efficiency

DC MOTOREN

a- Eigenschaften von DC Motoren

Mit den Entwicklungen bei elektronischen Komponenten haben DC Motoren neue Anwendungsbereiche gefunden. Regelungssysteme, die früher sehr teuer und im manchen Anwendungsfällen ungünstig waren, sind jetzt kompakt und günstig. Bei den DC Motoren ist kontrolliertes Anlauf, Moment- und Stromüberwachung mit Überlastschutz möglich. Es gibt viele günstige Sonderanwendungen für diese Motoren. Wegen oben genannten Eigenschaften werden die DC Motoren immer mehr bei unterschiedlichen Anwendungen benutzt.

b- Funktionsprinzip der DC Motoren

Bei DC Motoren ist eine Kommutatorwicklung im Rotor angeordnet, während der magnetische Fluss vom Stator erzeugt wird. Dies kann wiederum mittels einer Erregerwicklung oder durch Permanentmagnete geschehen. Wie bei der Synchronmaschine wird durch das Erregerfeld in der Ankerwicklung eine Wechsellspannung, die bei der Gleichstrommaschine jedoch durch den mechanischen Kommutator und die darauf schleifenden Bürsten in eine Gleichspannung umgeformt wird, induziert.

c- Arten von DC Motoren

Es gibt zwei verschiedene Wicklungen, nämlich Shunt- und Serial-Wicklung. Das Drehmoment-Drehzahl-Verhältnis ist für beide Wicklungen unterschiedlich.

d- Drehzahl Kontrolle für DC Motoren

Drehzahl von DC Motoren kann man mit Steuerung der DC Spannung ändern. DC Motoren mit Shunt Wicklungen ist ähnlich zu drei phasen AC Motoren zwischen maximalen Last und ohne Last. Drehzahl wird mit der Last reduziert. Mit kleineren Motoren wird dieser Differenz höher mit größeren Motoren kleiner. Der Drehzahlunterschied kann geregelt werden mit ($I \times R$) Veränderung. Wenn eine genaue Kontrolle gebraucht, soll ein Tachogenerator benutzt werden. Leistung des DC Motors;

$$P_g = U \times I = \frac{P_c}{\eta}$$

P_g : Eingangsleistung W
 P_c : Ausgangsleistung W
 U : Ankerspannung V
 I : Ankerstrom A
 η : Wirkungsgrad des Motors

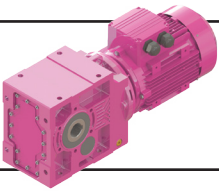

Genel Bilgiler

General Information

Einführung



Elektromanyetik Frenler

Bu tip frenlerin iki sürtünme yüzeyi vardır. Fren torku, voltaj uygulanmadığı zaman yayların kuvveti ile oluşturulur. Fren elektromanyetik alanın oluşumu ile serbest kalır. Bobinin beslenmesi ile mıknatıslanan balata baskı pulu, elektromıknatısa doğru çekilir. Bu hareket yayları baskı altına alır ve rotor mili üzerine takılan çoklu kama üzerinde aksiyal yönde serbest hareket edebilen balata serbest kalır. Akım kesildiğinde yayların baskısıyla, balata baskı pulu fren balatasına doğru itilir ve bu hareket rotoru frenler.

Fren Çeşitleri

a) Soğutmasız tip frenler

Motor fanı çıkarılıp motor kapağı arkasına akupile edilerek kullanılan frenler; genellikle sıkça açılıp kapanmayan ve kısa zaman aralıklarında çalışan sistemlerde tercih edilir.

b) Soğutmalı tip frenler

Motor fanı çıkarılıp motor kapağı arkasına akupile edilen ve motorun mili uzatılarak fren ve motorun arkasına alınan fan sayesinde daimi bir hava sirkülasyonu sağlanarak kullanılan frenlerdir. Genellikle uzun süreli çalışan ve kapalı mekanlarda kullanılan sistemlerde tercih edilir.

c) Manuel kol sistemli frenler

Çalışma sistemi olarak her iki fren tipinde de kullanılabilir (soğutmalı veya soğutmasız). Özel durumlarda (elektrik kesilmesi; mekanik problemler) üzerinde bulunan bir kol vasıtası ile sistemi yay baskısından kurtararak serbest kalmasını sağlayan frenlerdir. Genellikle manuel olarak sistemin açılması gereken yerlerde (otomatik giriş kapıları, dış cepe boyama asansörleri v.b.) tercih edilir.

Fren çalışma voltajları

Elektromanyetik frenler 230V AC veya 400V AC beslemeli olarak sipariş edilebilir. Frenler DC fren olmaları nedeni ile besleme ile fren bobini arasında fren tipine bağlı olarak, yarım dalga, tam dalga doğrultucular veya trafolar kullanılır. Özel olarak belirtilmedikçe 230V beslemeli ve yarım dalga doğrultuculu frenler kullanılmaktadır. Özel durumlar için YILMAZ Redüktöre danışınız.

a) 230V AC ile beslenen frenler

Motor klemens kutusundan alınan 230V'luk AC besleme fren tipine bağlı olarak yarım dalga veya tam dalga doğrultucu ile fren bobininin voltajına düşürülür. Fren bobin DC voltajı etiketi üzerinde belirtilmiştir.

b) 400V AC ile beslenen DC frenler

Motor klemens kutusundan alınan 400V'luk AC besleme, yarım dalga doğrultucu ile fren bobininin voltajına düşürülür. Fren bobininin DC voltajı etiket üzerinde belirtilmiştir.

c) 24V DC Frenler

Kullanılan fren momentinin büyüklüğüne göre besleme transformatörü seçilir. Şebekeden veya motorun klemens kutusundan alınan besleme voltajı transformatörde 29 V'a çevrilen gerilim tam dalga doğrultuculardan geçerek 24V DC'ye çevrilir ve fren bobini beslenir.

Electromagnetic Brakes

This type of brakes has two friction surfaces. Brake torque is generated by springs when no voltage is applied. The brake is electromagnetically released. On exciting the electromagnet means of the current, the armature plate is pulled towards the electromagnet itself, thrust loading the pressure spring and enabling the friction disc which is axially movable on the key, to turn freely. When current fails, the pressured springs drive the armature plate towards the disc, thus braking the motor shaft.

Brake Types

a) Brakes without cooling

This type of brakes are assembled on the back cover of the electric motor. There is no fan on the backside. This brake type is mostly preferred in short working times and short working cycles.

b) Fan cooled brakes

This type of brakes are assembled on the back cover of electric motor by removing the electric motor fan. A fan is coupled to the backside of the brake by extending the rotor shaft of the electric motor. Fan cooled brakes are preferred in long working times and closed places without airflow.

c) Brakes with hand release

This brakes can be released by help of an arm. It can be applied to both of the above mentioned brakes and used in special cases (fail of electric current, mechanical problems etc.) These brakes are mostly preferred if operation (re-lasing) without a current is needed (automatic controlled doors, gates, building wall painting elevators etc.).

Working Voltages

Electromagnetic brakes can be ordered with 230V AC or 400V AC supply voltage. The coil of brakes needs DC voltage and therefore depending on brake type a half wave, a full wave rectifier or transformer should be used between supply and coil voltage. As standard the brakes will be delivered with 230V supply voltage and half wave rectifier, if there is no special request. For special cases please contact YILMAZ Redüktor.

a) Brakes with 230V supply voltage

230V AC supply voltage from the motor terminal box will be reduced to the coil voltage depending on the brake type with half-wave or full-wave rectifier. DC brake coil voltage is indicated on the label.

b) Brakes with 400V supply voltage

400V AC supply voltage from the motor terminal box will be reduced to the coil voltage with half-wave rectifier. DC brake coil voltage indicated on the label.

c) 24V DC Brakes

The transformer's size is selected according to value of brake torque. The current is taken from the electric motor terminal box or from the electric panel and is transformed to 29V DC current. This current is transferred to 24V DC current with full-wave rectifier and supplies brake coil.

Elektromagnetische Bremsen

Die Bremse hat zwei Reibflächen und arbeitet nach dem Ruhestromprinzip. Im stromlosen Zustand wird das Bremsmoment durch den Druck der Feder erzeugt, während die Bremse beim Betrieb elektromagnetisch losgelassen wird. Durch die Erregung der Elektromagneten wird die Ankerscheibe zu den Elektromagneten gezogen und die Feder zusammagedrückt. Dadurch kann sich die Bremsenscheibe, die axial beweglich auf dem Mitnehmer angeordnet ist, frei drehen. Wird der Strom unterbrochen, drücken die Feder die Ankerscheibe gegen die Bremsenscheibe und halten die Motorwelle an.

Bremsearten:

a) Bremsen ohne Kühlung

Diese Bremsen sind für Kurzlaufzeiten geeignet. Die Lüfterhaube und Lüfter des Motors ist ausgebaut und die Bremse ist an dem Ende der Motorwelle befestigt.

b) Bremsen mit Kühlung

Diese Bremsen sind für lange Laufzeiten und kleine, abgedeckte Räume geeignet. Durch die Verlängerung der Motorwelle wurde Lüfter hinter dem Bremse und dem Motor verbunden. Somit wurde eine konstante Lüftung ermöglicht.

c) Bremsen mit Hebelarm

Diese Bremsenart kann mit oder ohne Kühlung verwendet werden. Diese Bremsen sind bei der speziellen Fälle, wie keine Spannung an der Leitung, mechanische Probleme usw., anwendbar. Die Bremse wird mit einem Hebelarm manuell betätigt. Diese Bremsen werden am meisten an den Stellen, wo die Lüftung ohne Spannung erfolgen soll, benutzt (automatische Türe, Wandaufzüge).

Betriebsspannungen

Elektromagnetische Bremsen können mit 230V AC oder 400V AC Versorgungsspannung bestellt werden. Die Wicklungen der Bremsen brauchen Gleichspannung und deswegen abhängig von Bremsenart zwischen Versorgungsspannung und Wicklungsspannung soll Halbwellen-, Vollweggleichrichter oder Transformator verwendet werden. Als Standard die Bremsen werden mit 230V Versorgungsspannung und Halbwellengleichrichter geliefert.

a) Bremsen mit 230V Versorgungsspannung

230V AC Versorgungsspannung von Klemmenkasten wird auf die Wicklungsspannung abhängig von der Bremsentyp mit Halbwellen-oder Vollweggleichrichter reduziert. Wicklungsspannung ist auf dem Etikett angegeben.

b) Bremsen mit 400V Versorgungsspannung

400V AC Versorgungsspannung von Klemmenkasten wird auf die Wicklungsspannung mit Halbwellengleichrichter reduziert. Wicklungsspannung ist auf dem Etikett angegeben.

c) 24 V DC Bremsen

Die Spannung wird von den Klemmkasten des Motors oder Elektrischrank entnommen. Diese Spannung wird zuerst mittels Transformator zu 24 V reduziert. Danach wird diese Spannung mit Hilfe von Gleichrichter zu Gleichstromspannung umgewandelt. Die Größe des Transformators ist abhängig von der Größe des Bremsmoments.

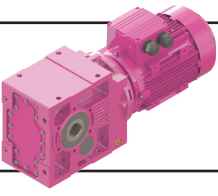

Genel Bilgiler General Information Einführung



d) Şok ikazlı trafolar

Büyük güçteki ve momentteki frenlerin manyetik doyuma ulaşmaları uzun zaman alır. Şok ikazlı trafolar frenin yay baskısını yenmede gecikmesini engellemek için kullanılır ve zaman rölesi yardımı ile çok kısa bir süre normal besleme voltajının iki katı ile (48V DC) beslenip sistemin ani açılmasını sağlar. Bu sayede gecikmeli açılımda ortaya çıkacak sürtünmeyi engellemeye yarayan bir trafo şeklindedir.

Fren bağlantı şekli

a) Gecikmeli frenleme

Genellikle sistemin yavaş ve kaydırılarak durması gereken yerlerde tercih edilen bağlantı şeklidir. Vinç yürütme motorlarındaki sarsıntıyı önlemek için gecikmeli bağlantı şekli kullanılır. Frenler fabrika çıkışında gecikmeli bağlantıya uygun ayarlanır.

b) Ani frenleme

Genellikle sistemin enerjisi kesildiği anda ani olarak durdurulması gereken sistemlerde kullanılan bağlantı şeklidir. Vinç kaldırma sistemleri, asansör motorlarında kullanılan bağlantı şeklidir.

d) Shock voltage supply transformer

Brakes which consist of high power and torques take long time to get in electromagnetic field. Shock voltage supply transformers with time relay are aiming to overcome spring pressure delaying for brakes. Also this transformers provide to open system suddenly by feeding double(48V DC) voltage in a short time and preventing to frictional losses occurring in delayed opening.

Connection Types

a) Delayed Braking

Generally this type of connection uses in slow and sliding brake intended systems. Delayed connection type using to prevent shock loadings in crane driving systems. Brakes are setting up to delayed connection if any other types are not specified by customer

b) Sudden Braking

This type of connections are mostly used in systems when short braking times are needed. The braking torque will be produced as soon as the current fails. These brakes are mostly used in hoisting of lifting units and elevators.

d) Trafos mit Schock-Spannung

Diese Transformatoren werden bei großen Bremsen mit hohen Momenten verwendet. Da die große Bremsen eine lange Zeit braucht, um die erforderliche magnetische Feld zu erzeugen, wird an der Bremse kurz 48V Gleichstromspannung angelegt, um die Zeit zur Bildung von magnetischem Feld zu kürzen. Dies ermöglicht kürzere Reibungszeiten beim Start.

Schaltungsarten:

a) Verspätetes Bremsen

Diese Schaltung wird benutzt, wenn ein langsames und gleitendes Bremsen erforderlich ist. Am meisten wird es bei Fahrtriebmotoren von Aufzügen verwendet. Wenn keine Angabe bei der Bestellung gegeben wird, werden die Bremsen mit verspäteter Schaltung geliefert.

b) Schnelles Bremsen:

Allgemein verwendet man diese Schaltung bei Bedarf an plötzlichen Bremsen in dem Augenblick, in dem das System keine Energie mehr erhält. Diese Schaltungsart wird meist bei Kräne und Motoren von Aufzüge verwendet.

Gecikmeli Frenleme / Delayed Running Brake / Verspätete Bremsung
(230 V)

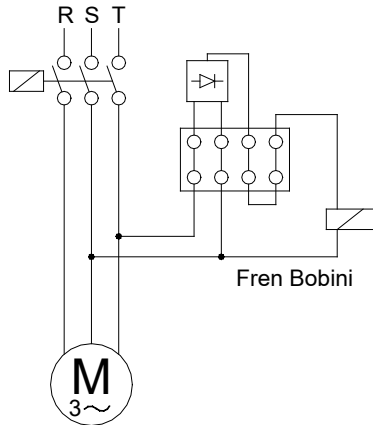

Ani Frenleme / Sudden Brake / Plötzliche Bremsung
(230 V)

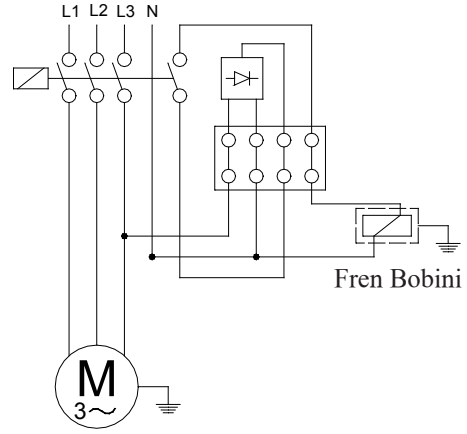

Gecikmeli Frenleme / Delayed Running Brake / Verspätete Bremsung
(24 V)

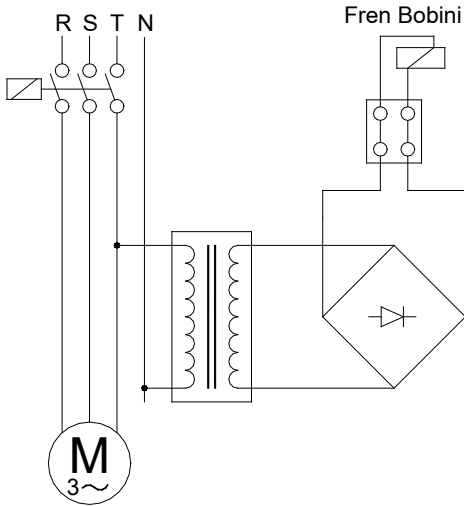

Ani Frenleme / Sudden Brake / Plötzliche Bremsung
(24 V)

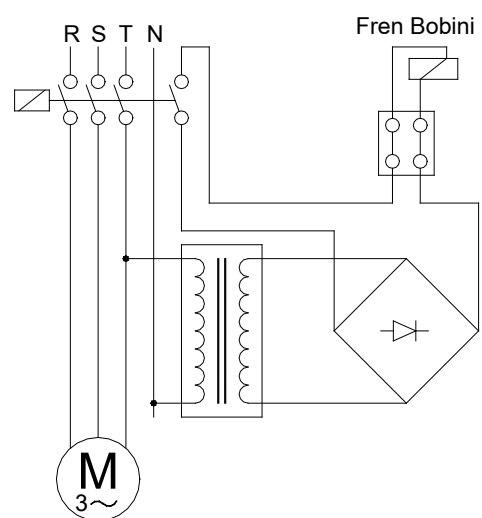

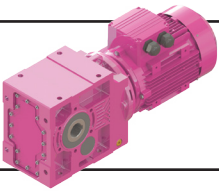

Genel Bilgiler

General Information

Einführung



Fren Seçimi:

Doğru bir fren seçimi için aşağıdaki parametreler bilinmelidir.

- $I_{tot} [kg \cdot m^2]$: Motor miline indirgenmiş toplam atalet momenti
- $n_0 [d/dak]$: Maksimum motor devir sayısı
- $t_f [s]$: İstenilen en uzun frenleme zamanı
- c_t : Anahtarın devreye girme zamanı katsayısı (ortalama 0,995).
- $M_L [Nm]$: Sistemin statik tork ihtiyacı.
- C_s : Emniyet katsayısı ($C_s \geq 2$ olmalı)

Gerekli fren momenti aşağıdaki şekilde hesaplanır:

a) M_L Statik yük torku, motor dönüş yönünde (motorun dönüşüne yardımcı olarak, yükün indirilmesi veya hızlandırıcı sabit yük momenti hali):

$$M_{fc} = \frac{(2 \pi \times n_0 \div 60) \times I_{tot}}{t_f \times c_t} + M_L$$

b) M_L Statik yük torku, motor aksi dönüş yönünde (motorun dönüşüne engel olarak, yükün yukarı kaldırılması veya frenleyici sabit yük/direnç momenti hali):

$$M_{fc} = \frac{(2 \pi \times n_0 \div 60) \times I_{tot}}{t_f \times c_t} - M_L$$

Yukarıda bulunan sonuç C_s katsayısı ile çarpılarak ($C_s \geq 2$), fren momenti seçilir;

$$M_f = M_{fc} \times C_s$$

Yaklaşım Yolu ile Fren Seçimi:

Eğer yalnızca motorun gücü ve en yüksek devri biliniyor ise :

W [Watt]: Motorun nominal gücü

$$M_f = \frac{W}{\left(\frac{2\pi \times n_0}{60}\right)} \times C_s \quad (C_s \geq 2)$$

Brake Selection:

To select a brake correctly the following data are necessary;

- $I_{tot} [kg \cdot m^2]$: The total inertia of rotating parts reduced at the motor shaft
- $n_0 [rpm]$: Maximum motor speed.
- $t_f [s]$: The maximum admitted time of the braking.
- c_t : Coefficient of switch on time (average 0,995).
- $M_L [Nm]$: Required static torque of system.
- C_s : Safety coefficient ($C_s \geq 2$)

The necessary braking torque calculates below;

a) The static load torque M_L , same direction of motor rotation (Descent of a load or steady resisting torque which favours the rotation of the motor)

$$M_{fc} = \frac{(2 \pi \times n_0 \div 60) \times I_{tot}}{t_f \times c_t} + M_L$$

b) The static load torque M_L , opposes the rotation of the motor (Lifting of a load or steady resisting torque which opposes the rotation of the motor)

$$M_{fc} = \frac{(2 \pi \times n_0 \div 60) \times I_{tot}}{t_f \times c_t} - M_L$$

The necessary braking torque will result from the following equation using C_s ($C_s \geq 2$);

$$M_f = M_{fc} \times C_s$$

Approximated Brake Selection

Its only the motor power and its maximum speed are known:

W [Watt]: Motor Nominal Power

$$M_f = \frac{W}{\left(\frac{2\pi \times n_0}{60}\right)} \times C_s \quad (C_s \geq 2)$$

Bremswahl:

Um die richtige Bremse auszuwählen, braucht man unten aufgelistete Variablen;

- $I_{tot} [kg \cdot m^2]$: Die Gesamtträgheit der rotierenden Teile (siehe Anwendungsbeispiele)
- $n_0 [U/min]$: Die höchste Drehzahl des Motors
- $t_f [s]$: Die längste zulässige Bremszeit
- c_t : Reduktionskoeffizient der Tätigkeitszeit (gemittelt 0,995).
- $M_L [Nm]$: Vom system benötigtes, statisches Drehmoment.
- C_s : Sicherheitskoeffizient ($C_s \geq 2$)

Die benötigte Bremskraft wird wie folgt berechnet:

a) konstantes Belastungsmoment M_L , das die Motordrehung fördert (konstante Erhöhung der Motorgeschwindigkeit oder Herunterlassen der Last)

$$M_{fc} = \frac{(2 \pi \times n_0 \div 60) \times I_{tot}}{t_f \times c_t} + M_L$$

b) konstantes Belastungsmoment M_L , das sich entgegen der Motordrehung widersetzt (konstante Verminderung der Motorgeschwindigkeit oder Aufheben der Last)

$$M_{fc} = \frac{(2 \pi \times n_0 \div 60) \times I_{tot}}{t_f \times c_t} - M_L$$

Wenn die Bremskraft mit dem Sicherheitskoeffizient C_s ($C_s \geq 2$) multipliziert wird, erhält man die erforderliche Bremskraft;

$$M_f = M_{fc} \times C_s$$

Abschätzung zur Bremswahl

Wenn man nur die Motorleistung und die höchste Drehzahl kennt, kann die Bremskraft mit der folgenden Formel annähernd berechnet werden:
W [Watt]: Nennleistung des Motors

$$M_f = \frac{W}{\left(\frac{2\pi \times n_0}{60}\right)} \times C_s \quad (C_s \geq 2)$$

Standart Frenler / Standard Brakes / Standart Bremsen

Fren statik momenti [Nm] Brake Static Torque [Nm] Statische Bremskraft [Nm]	4,5	8	12	16	35	60	80	150	200
Fren Dinamik Momenti [Nm] Brake Dynamic Torque [Nm] Dynamische Bremskraft [Nm]	3,6	6,4	9,6	12,8	28	48	64	120	160
Maksimum Motor Hızı [d/dak] Maximum Motor Speed [rpm] Maximale Motordrehzahl [U/min]	3000	3000	3000	3000	3000	3000	3000	1500	1500
Giriş Gücü [W] Input Power [W] Antriebsleistung [W]	15	20	25	30	45	50	55	60	65

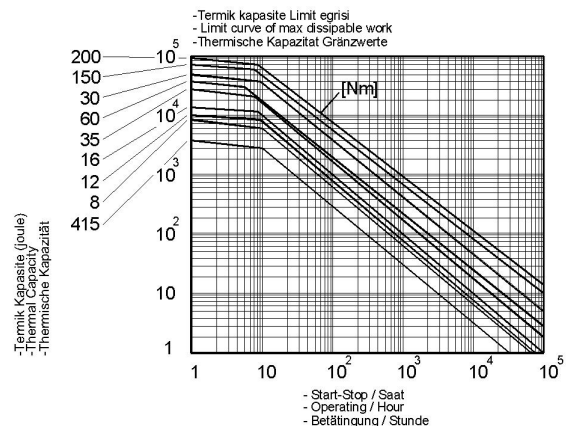

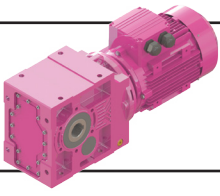

Genel Bilgiler

General Information

Einführung



Frenin Termik Kapasitesi

Yukarıdaki seçime ek olarak frenin termik kapasitesinin kontrol edilmesi gerekir. L (joule) olarak gerekli soğutma işi aşağıdaki formüller ile hesaplanır ve "Termik kapasite limit eğrisi" kullanılarak eğrinin altında kalıp kalmadığı kontrol edilir.

a) M_L Statik yük torku motor dönüş yönünde (motorun dönüşüne yardımcı olarak, yükün indirilmesi hali)

$$L = \frac{I_{tot} \times (2 \pi \times n_0 \div 60)^2}{2} \times \left(\frac{M_f}{M_f - M_L} \right)$$

b) M_L Statik yük torku motor aksi dönüş yönünde (motorun dönüşüne engel olarak, yükün kaldırılması hali):

$$L = \frac{I_{tot} \times (2 \pi \times n_0 \div 60)^2}{2} \times \frac{M_f}{M_f + M_L}$$

c) M_L Statik yük torku sabit, motor yönünde veya aksi yönde (kaldırma ve indirme harici hızlandırıcı veya frenleyici sabit bir yük momenti hali).

$$L = \frac{I_{tot} \times (2 \pi \times n_0 \div 60)^2}{2}$$

Fren Hava Boşluğunun Ayarı:

Frenden sürekli aynı performansın alınabilmesi için, fren balatasının aşınmasına bağlı olarak, fren hava boşluğu belirli zaman aralıklarında yeniden ayarlanmalıdır. Fren hava boşluğu ayar zaman aralığı ve ayarın yapılması için firmamıza danışınız.

Fren Seçim Örneği:

İstenilen en uzun frenleme zamanı: 0,5 sn.

Motor devri: 1400 d/dak

Motoru indirgenmiş toplam atalet momenti:

0,08 kgm²

Gerekli çalışma momenti: 50 Nm

Yük Durumu: Yük motor dönüş yönü ile aynı (Vinçten yük indirilmesi: Saatte dur-kalk sayısı:30)

$$M_{fc} = \frac{(2 \pi \times 1400 \div 60)}{0,5 \times 0,995} + 50 = 73,6 \text{ Nm}$$

$$M_f = 73,6 \times 2 = 147,2 \text{ Nm}$$

Standart frenler tablosundan 150 Nm lik fren seçilebilir.

Gerekli termik kapasite;

$$L = \frac{0,08 \times (2 \pi \times 1400 \div 60)^2}{2} \times \left(\frac{147,2}{147,2 - 50} \right)$$

=1302,0 < 18000 Joule (150 Nm eğrisinden)
150 Nm lik fren uygun görülüyor.

The Thermal Capacity of Brake

The thermal capacity of the brake must also be checked after the above mentioned calculations. The heat dissipation energy L (joule) can be calculated from the following equation and must be checked if the result is under the limit curve shown on "Limit curve of may dissipable work".

a) The static load torque M_L , favours the rotation of the motor (Descent of a load which favours the rotation of the motor)

$$L = \frac{I_{tot} \times (2 \pi \times n_0 \div 60)^2}{2} \times \left(\frac{M_f}{M_f - M_L} \right)$$

b) The static load torque M_L , opposes the rotation of the motor (Lifting of a load which opposes the rotation of the motor)

$$L = \frac{I_{tot} \times (2 \pi \times n_0 \div 60)^2}{2} \times \frac{M_f}{M_f + M_L}$$

c) The static load torque M_L , is constant and opposes or favours the rotation of the motor (except lifting of a load)

$$L = \frac{I_{tot} \times (2 \pi \times n_0 \div 60)^2}{2}$$

Adjustment of the air-gap:

In order to obtain the same performance from the brake during its lifetime, the air-gap of the brake must be re-adjusted after a limited time of operation. For the air-gap and the time interval of the adjustment please contact us.

Selection Example:

The maximum admitted time for braking 0,5 s

Motor speed: 1400 rpm

Total inertia reduced at motor shaft: 0,08 kgm²

Required operating torque: 50 Nm

Nature of load: Load direction is same as motor direction (Unloading process: Start-stop time per hour :30)

$$M_{fc} = \frac{(2 \pi \times 1400 \div 60)}{0,5 \times 0,995} + 50 = 73,6 \text{ Nm}$$

$$M_f = 73,6 \times 2 = 147,2 \text{ Nm}$$

From the brake selection table a standard brake of 150 Nm is selected.

Necessary thermal capacity

$$L = \frac{0,08 \times (2 \pi \times 1400 \div 60)^2}{2} \times \left(\frac{147,2}{147,2 - 50} \right)$$

=1302,0 < 18000 Joule (from 150 Nm curve)
The selected brake with 150 Nm is suitable.

Thermische Kapazität der Bremsen

Nach den oben genannten Berechnungen muss die Thermische Kapazität überprüft werden. Die Wärme, d.h. die gebrauchte Energie L, werden mit den folgenden Formeln berechnet. Die gerechnete Kapazitätswerte sollen unter dem Grenzkurve "Thermische Kapazität Grenzwerte" der gewählten Bremse liegen.

a) Konstantes Belastungsmoment M_L , das die Motordrehung fördert (Herunterlassen der Last)

$$L = \frac{I_{tot} \times (2 \pi \times n_0 \div 60)^2}{2} \times \left(\frac{M_f}{M_f - M_L} \right)$$

b) Konstantes Belastungsmoment M_L , das sich entgegen der Motordrehung widersetzt (Aufheben der Last)

$$L = \frac{I_{tot} \times (2 \pi \times n_0 \div 60)^2}{2} \times \frac{M_f}{M_f + M_L}$$

c) Konstantes Belastungsmoment M_L , das sich gegen der Motorbewegung widersetzt oder die Motorrotation fördert (Konstante Verminderung oder Erhöhung der Motorgeschwindigkeit, kein Herunterlassen oder Aufheben der Last)

$$L = \frac{I_{tot} \times (2 \pi \times n_0 \div 60)^2}{2}$$

Einstellung des Luftspaltes:

Um eine immer konstant bleibende Bremsfähigkeit zu erhalten, muss das Luftspalt nach einer bestimmten Arbeitszeit neu eingestellt werden. Für die Bestimmung des Luftspaltes und die Einstellzeiten bitten wir Sie um Rückfrage.

Beispiel für eine Auswahl:

Die höchste zulässige Bremszeit: 0,5 s

Motordrehzahl: 1400 U/min

Gesamträgheit der rotierenden Teile: 0,08 kgm²

Das auf das System wirkende Drehmoment: 50 Nm

Belastungsart: Drehmoment, das die Motorrotation fördert (Herunterlassen der Last) Betätigungen pro Stunde:30

$$M_{fc} = \frac{(2 \pi \times 1400 \div 60)}{0,5 \times 0,995} + 50 = 73,6 \text{ Nm}$$

$$M_f = 73,6 \times 2 = 147,2 \text{ Nm}$$

Eine Bremse von 150 Nm kann man auswählen.

Die thermische Kapazität;

$$L = \frac{0,08 \times (2 \pi \times 1400 \div 60)^2}{2} \times \left(\frac{147,2}{147,2 - 50} \right)$$

=1302,0 < 18000 Joule (von 150 Nm Kurve) Die ausgewählte 150 Nm Bremse ist ausreichend.

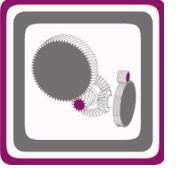
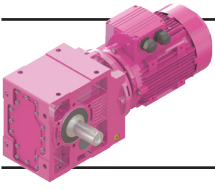

Güç ve Devir Tabloları

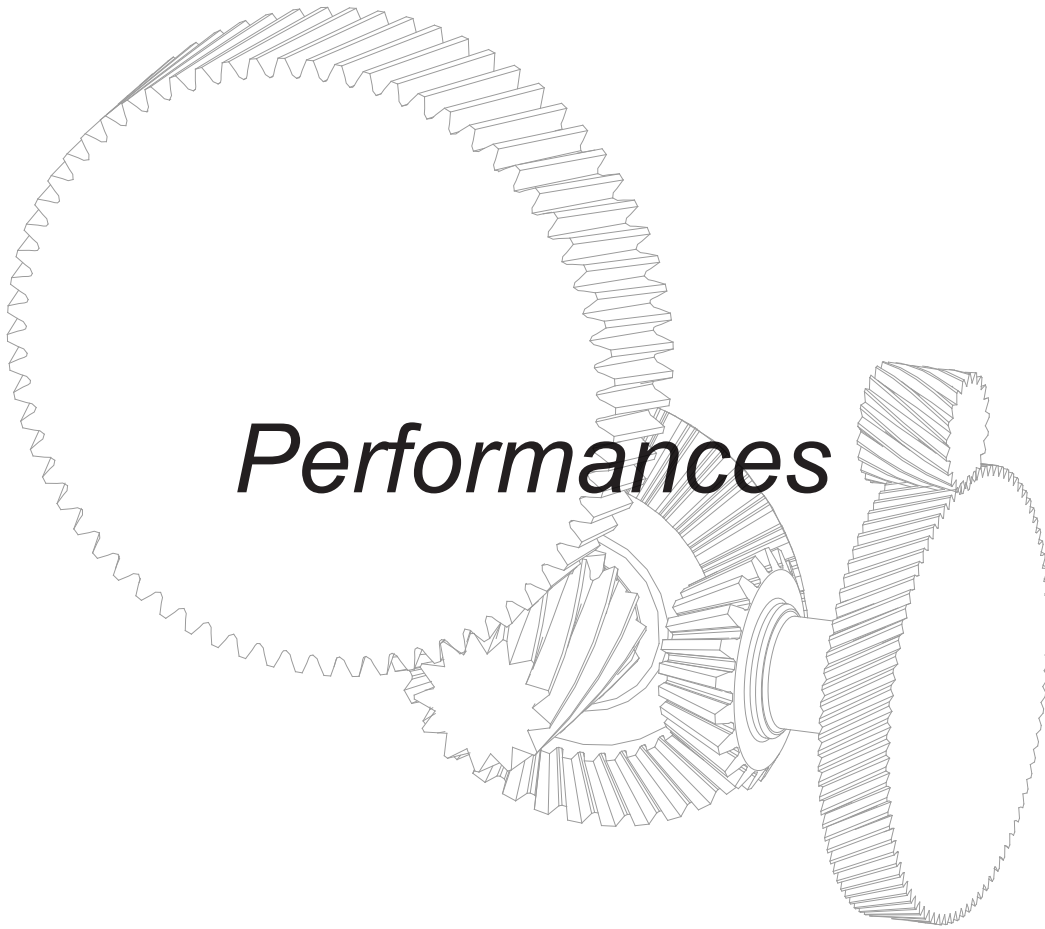

Leistung und Drehzahlübersicht

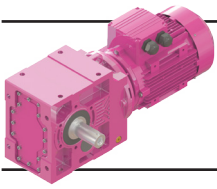

K Serisi Motorlu Güç Devir Sayfaları

K Series Geared Motors Performance Tables

K Serien Getriebemotoren Leistung und Drehzahlübersicht

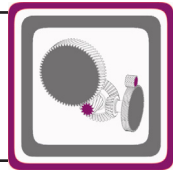

Güç	Çıkış Devri	Çıkış Momenti	Çevrim Oranı	Güv. Rad. Yük Çıkış	Servis Faktörü	Tipi	Anma Akımı	Ağırlık	Ölçü Sayfası	Motor Verim Snf.*
Power	Output Speeds	Output Torque	Ratio	Per.O. Loads (Output)	Service Factors	Type	Rated Current	Weight	Dim. Page	Motor Eff. Class
Leistung P _g [kW] P _g [HP]	Abtriebswelle Drehzahlen n ₂ [r.p.m]	Abtriebswelle Drehmomente M ₂ [Nm]	Übersetzung i	Zul.Querkräfte (Abtrieb) F _{qam} [N]	Betriebsfaktor f _s	Typ	Nennstrom [A]	Gewicht ~ [kg]	Maße Seite	Motor Effizienz-klasse
0,12 0,16	0,24	3625	5587,93	7240	0,7	KR576-G63/4a	0,41	156	160	IE1
	0,34	2626	4047,32	23398	1,0					
	0,38	2335	3597,31	26003	1,2					
	0,50	1792	2755,47	29938	1,5					
	0,59	1516	2328,84	31626	1,8					
	0,61	1484	2236,28	31807	1,8	KR575-G63/4a	0,41	151	160	IE1
	0,72	1255	1890,04	33033	2,2					
	1,0	909	1368,95	34685	3,0					
	0,48	1872	2873,07	13041	0,8	KR476-G63/4a	0,41	113	148	IE1
	0,51	1740	2663,91	14648	0,9					
	0,55	1629	2495,47	15826	1,0					
	0,63	1428	2183,54	17680	1,1					
0,77	1174	1767,90	19651	1,3	KR475-G63/4a	0,41	109	148	IE1	
0,92	981	1476,60	20883	1,6						
1,0	927	1395,04	21205	1,7						
1,1	811	1218,61	21859	1,9						
1,2	762	1142,99	22124	2,0						
1,4	648	971,77	22698	2,4						
1,5	602	901,03	22917	2,6						
1,6	564	844,06	23096	2,7						
0,80	1104	1699,70	7414	0,7	KR376-G63/4a	0,41	68	136	IE1	
0,91	977	1500,87	9855	0,8						
1,0	913	1401,91	10823	0,9						
1,2	773	1184,90	12605	1,1						
1,2	728	1094,97	13096	1,1	KR375-G63/4a	0,41	64	136	IE1	
1,4	644	968,01	13938	1,3						
1,7	542	814,20	14798	1,5						
2,0	461	692,22	15452	1,8						
2,3	395	593,11	15919	2,1						
2,5	358	536,75	16168	2,3						
2,9	317	473,96	16429	2,6						
3,1	296	442,71	16555	2,8						
1,0	877	1347,72	13774	0,7						KR286-G63/4a
1,2	742	1139,09	14977	0,8						
1,3	698	1052,64	15307	0,9	KR285-G63/4a	0,41	49	124	IE1	
1,5	618	930,59	15898	1,0						
1,7	520	782,73	16527	1,2						
2,1	442	665,46	16974	1,4						
2,4	379	570,18	17307	1,6						
2,6	343	516,00	17484	1,7						
3,0	304	455,64	17670	2,0						
3,2	284	425,60	17759	2,1						
3,8	240	359,71	17948	2,5						
1,5	574	881,79	11145	0,8	KR276-G63/4a	0,41	30	112	IE1	
1,9	479	735,42	11863	0,9						
1,9	479	719,79	11862	0,9	KR275-G63/4a	0,41	29	112	IE1	
2,0	449	675,13	12064	1,0						
2,4	382	573,99	12488	1,2						

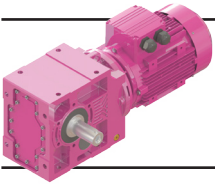

K Serisi Motorlu Güç Devir Sayfaları

K Series Geared Motors Performance Tables

K Serien Getriebemotoren Leistung und Drehzahlübersicht

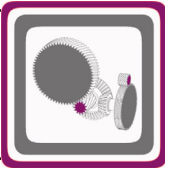

Güç	IE3 Çıkış Devri	IE3 Çıkış Momenti	Çevrim Oranı	IE3 Güv. Rad. Yük Çıkış	IE3 Servis Faktörü	Tipi	Anma Akımı	Ağırlık	Ölçü Sayfası	Motor Verim Snf.*						
Power	Output Speeds	Output Torque	Ratio	Per.O. Loads (Output)	Service Factors	Type	Rated Current	Weight	Dim. Page	Motor Eff. Class						
Leistung P _g [kW] P _g [HP]	Abtriebswelle Drehzahlen n ₂ [r.p.m]	Abtriebswelle Drehmomente M ₂ [Nm]	Übersetzung i	Zul.Querkräfte (Abtrieb) F _{qam} [N]	Betriebsfaktor f _s	Typ	Nennstrom [A]	Gewicht ~ [kg]	Maße Seite	Motor Effizienz-klasse						
0,12 0,16	2,7	332	498,55	12772	1,4	KR275-G63/4a	0,41	29	112	IE1						
	3,1	291	436,24	12990	1,5											
	3,8	241	360,73	13234	1,9											
	4,5	201	300,85	13412	2,2											
	5,4	168	252,20	13557	2,7											
	6,3	145	215,91	13646	3,1											
	6,8	134	200,35	13683	3,4											
	10	89	131,68	14145	4,0											
	9,9	106	138,53	10316	2,6											
	11	92	119,62	9906	3,0											
	11	99	129,27	6729	1,4	KR103-G63/4a	0,41	15	100	IE1						
	12	89	116,34	6883	1,6											
	13	81	105,26	7001	1,7											
	15	68	88,87	7157	2,1											
	18	59	76,13	7256	2,4											
	20	52	67,22	7315	2,7											
	22	48	62,79	7342	2,9											
	11	93	120,91	3531	0,9											
	14	75	98,44	4201	1,1											
	15	69	89,62	4408	1,2											
	17	62	80,66	4585	1,3	KR003-G63/4a	0,41	15	96	IE1						
	20	52	67,44	4810	1,5											
	24	44	57,16	4944	1,8											
	28	38	48,93	5038	2,1											
	30	35	45,41	5072	2,3											
	39	27	35,34	4972	2,9											
	46	23	29,95	4742	3,5											
	53	20	25,64	4532	4,0											
	57	18	23,79	4433	4,0											
		69	15	19,88	4199						4,0	KR002-G63/4a	0,41	14	96	IE1
84		13	16,18	3946	4,0											
93		11	14,73	3834	4,0											
103		10	13,26	3712	4,0											
123		8,6	11,09	3512	4,0											
145		7,3	9,40	3334	4,0											
170		6,3	8,04	3175	4,0											
183		5,8	7,46	3101	4,0											
0,18 0,25		0,12	12027	7938,12	96372	1,2	KR876-3E71M/6C	0,55	646	196	IE3					
		0,13	10648	7017,76	101842	1,4										
	0,16	8974	5902,70	107759	1,7											
	0,19	7644	5018,35	111973	2,0											
	0,22	6560	4299,81	115121	2,3											
	0,24	5943	3891,23	116636	2,5											
	0,27	5193	3396,71	118622	2,9											
	0,31	4585	2996,39	120155	3,3											
	0,35	4081	2665,68	121374	3,7											
	0,39	3658	2387,89	123281	4,0											
	0,45	3175	2074,42	128178	4,0	KR876-2E71M/6B	0,60	645	196	IE2						
	0,37	3766	3597,31	-	0,7											
	0,49	2890	2755,47	20604	0,9											
	0,58	2445	2328,84	25068	1,1											
	0,60 0,71	2393	2236,28	25513	1,1						KR575-G63/4b	0,60	152	160	IE1	
		2025	1890,04	28383	1,3											

*: IE2 ve IE3 motorlu redüktör fiyatları farklıdır. / Geared motor prices are different for IE2 and IE3 motors. / Preise von Getrieben mit IE2 und IE3 Motoren sind unterschiedlich.

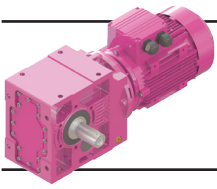

K Serisi Motorlu Güç Devir Sayfaları

K Series Geared Motors Performance Tables

K Serien Getriebemotoren Leistung und Drehzahlübersicht

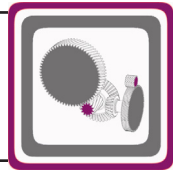

Güç	Çıkış Devri	Çıkış Momenti	Çevrim Oranı	Güv. Rad. Yük Çıkış	Servis Faktörü	Tipi	Anma Akımı	Ağırlık	Ölçü Sayfası	Motor Verim Snf.*
Power	Output Speeds	Output Torque	Ratio	Per.O. Loads (Output)	Service Factors	Type	Rated Current	Weight	Dim. Page	Motor Eff. Class
Leistung P _g [kW] P _g [HP]	Abtriebswelle Drehzahlen n ₂ [r.p.m]	Abtriebswelle Drehmomente M ₂ [Nm]	Übersetzung i	Zul.Querkräfte (Abtrieb) F _{qam} [N]	Betriebsfaktor f _s	Typ	Nennstrom [A]	Gewicht ~ [kg]	Maße Seite	Motor Effizienz-klasse
0,18 0,25	1,0	1467	1368,95	31902	1,8	KR575-G63/4b	0,60	152	160	IE1
	1,1	1304	1216,74	32739	2,1					
	1,4	1002	932,00	34264	2,7					
	1,7	848	787,70	34954	3,2					
0,76 0,91 1,0 1,1 1,2 1,4 1,5 1,6	0,76	1893	1767,90	12768	0,8	KR475-G63/4b	0,60	110	148	IE1
	0,91	1583	1476,60	16283	1,0					
	1,0	1496	1395,04	17091	1,0					
	1,1	1309	1218,61	18641	1,2					
	1,2	1228	1142,99	19241	1,3					
	1,4	1045	971,77	20486	1,5					
	1,5	971	901,03	20944	1,6					
	1,6	909	844,06	21342	1,7					
2,0 2,2 2,5 3,0 3,2	2,0	752	472,63	22172	2,1	KR474-3E71M/6C	0,55	100	144	IE3
	2,2	673	422,88	22575	2,3					
	2,5	592	371,35	22937	2,6	KR474-2E71M/6B	0,60	99	144	IE2
	3,0	495	310,16	23382	3,1					
	3,2	468	293,03	23501	3,3					
1,2 1,4 1,6 1,9 2,3	1,2	1174	1094,97	5584	0,7	KR375-G63/4b	0,60	70	136	IE1
	1,4	1038	968,01	8794	0,8					
	1,6	874	814,20	11365	0,9					
	1,9	744	692,22	12924	1,1					
	2,3	638	593,11	13987	1,3					
2,5 3,1 3,6	2,5	584	367,43	14465	1,4	KR374-3E71M/6C	0,55	62	132	IE3
	3,1	471	295,76	15381	1,7					
	3,6	413	259,36	15796	2,0	KR374-2E71M/6B	0,60	61	132	IE2
3,6	406	367,43	15848	2,0						
4,5	327	295,76	16367	2,5						
5,2	287	259,36	16610	2,9						
1,7 2,0 2,4	1,7	839	782,73	14151	0,7	KR285-G63/4b	0,60	49	124	IE1
	2,0	714	665,46	15200	0,8					
	2,4	612	570,18	15951	1,0					
2,6 3,3 3,7	2,6	561	353,22	16274	1,1	KR284-3E71M/6C	0,55	47	120	IE3
	3,3	452	284,33	16924	1,3					
	3,7	396	249,33	17220	1,5	KR284-2E71M/6B	0,60	44	120	IE2
3,8	389	353,22	17257	1,5						
4,7	313	284,33	17626	1,9						
5,4	275	249,33	17799	2,2						
6,1	243	220,43	17935	2,5						
2,3 2,7 3,1 3,7 4,5 5,3 6,2 6,7	2,3	616	573,99	10785	0,7	KR275-G63/4b	0,60	29	112	IE1
	2,7	535	498,55	11448	0,8					
	3,1	469	436,24	11945	1,0					
	3,7	388	360,73	12451	1,2					
	4,5	324	300,85	12816	1,4					
	5,3	272	252,20	13085	1,7					
	6,2	233	215,91	13268	1,9					
	6,7	217	200,35	13343	2,1					
8,2 9,6	8,2	184	113,65	13475	2,4	KR273-3E71M/6C	0,55	30	108	IE3
	9,6	157	96,68	13588	2,9					

: IE2 ve IE3 motorlu redüktör fiyatları farklıdır. / Geared motor prices are different for IE2 and IE3 motors. / Preise von Getrieben mit IE2 und IE3 Motoren sind unterschiedlich.

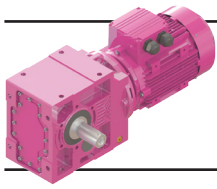

K Serisi Motorlu Güç Devir Sayfaları

K Series Geared Motors Performance Tables

K Serien Getriebemotoren Leistung und Drehzahlübersicht

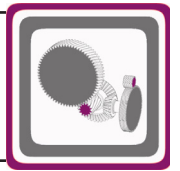

Güç	IE3 Çıkış Devri	IE3 Çıkış Momenti	Çevrim Oranı	IE3 Güv. Rad. Yük Çıkış	IE3 Servis Faktörü	Tipi	Anma Akımı	Ağırlık	Ölçü Sayfası	Motor Verim Snf.*
Power	Output Speeds	Output Torque	Ratio	Per.O. Loads (Output)	Service Factors	Type	Rated Current	Weight	Dim. Page	Motor Eff. Class
Leistung P _g [kW] P _g [HP]	Abtriebswelle Drehzahlen n ₂ [r.p.m]	Abtriebswelle Drehmomente M ₂ [Nm]	Übersetzung i	Zul.Querkräfte (Abtrieb) F _{qam} [N]	Betriebsfaktor f _s	Typ	Nennstrom [A]	Gewicht ~ [kg]	Maße Seite	Motor Effizienz-klasse
0,18 0,25	11	136	83,48	13672	3,3	KR273-3E71M/6C KR273-2E71M/6B	0,55	30	108	IE3
								0,60	29	
	12 14	127 109	113,65 96,68	13715 13835	3,5 4,0	KR273-G63/4b	0,60	28	108	IE1
	6,7 7,8 8,9 9,5	236 204 179 168	138,53 119,62 104,49 98,01	8627 9260 9670 9834	1,2 1,4 1,6 1,7	KR203-3E71M/6C KR203-2E71M/6B	0,55	19	104	IE3
								0,60	18	
	9,7 11 13 14 16	164 141 124 116 99	138,53 119,62 104,49 98,01 83,32	9866 9527 9212 9063 8687	1,7 2,0 2,3 2,4 2,8	KR203-G63/4b	0,60	26	104	IE1
	8,8 10	179 152	105,26 88,87	4409 5481	0,8 0,9	KR103-3E71M/6C KR103-2E71M/6B	0,55	15	100	IE3
								0,60	14	
	10 12 13 15 18 20 21 25 30 35	152 137 124 105 90 80 74 63 53 45	129,27 116,34 105,26 88,87 76,13 67,22 62,79 53,07 44,32 38,22	5455 5902 6228 6624 6873 7021 7086 6957 6622 6353	0,9 1,0 1,1 1,3 1,6 1,8 1,9 2,2 2,7 3,0	KR103-G63/4b	0,60	15	100	IE1
	15 17 20 23 27 30 38 45 52 56	106 95 80 68 58 54 42 36 30 28	89,62 80,66 67,44 57,16 48,93 45,41 35,34 29,95 25,64 23,79	2782 3405 4058 4437 4678 4765 4802 4602 4415 4326	0,8 0,8 1,0 1,2 1,4 1,5 1,9 2,3 2,6 2,8	KR003-G63/4b	0,60	15	96	IE1
	67 83 91 101 121 143 167 180	24 19 18 16 13 11 9,7 9,0	19,88 16,18 14,73 13,26 11,09 9,40 8,04 7,46	4113 3879 3775 3661 3471 3303 3150 3079	3,4 3,9 4,0 4,0 4,0 4,0 4,0 4,0	KR002-G63/4b	0,60	15	96	IE1
	213 254 300 351 378	7,5 6,2 5,3 4,5 4,2	13,26 11,09 9,40 8,04 7,46	2923 2764 2624 2498 2440	4,0 4,0 4,0 4,0 4,0	KR002-G63/2a	0,50	10	96	IE1

*: IE2 ve IE3 motorlu redüktör fiyatları farklıdır. / Geared motor prices are different for IE2 and IE3 motors. / Preise von Getrieben mit IE2 und IE3 Motoren sind unterschiedlich.

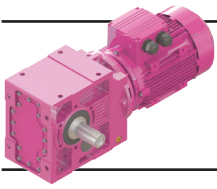

K Serisi Motorlu Güç Devir Sayfaları

K Series Geared Motors Performance Tables

K Serien Getriebemotoren Leistung und Drehzahlübersicht

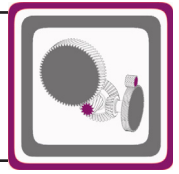

Güç	IE3 Çıkış Devri	IE3 Çıkış Momenti	Çevrim Oranı	IE3 Güv. Rad. Yük Çıkış	IE3 Servis Faktörü	Tipi	Anma Akımı	Ağırlık	Ölçü Sayfası	Motor Verim Snf.*
Power	Output Speeds	Output Torque	Ratio	Per. O. Loads (Output)	Service Factors	Type	Rated Current	Weight	Dim. Page	Motor Eff. Class
Leistung P _g [kW] P _g [HP]	Abtriebswelle Drehzahlen n ₂ [r.p.m]	Abtriebswelle Drehmomente M ₂ [Nm]	Übersetzung i	Zul.Querkräfte (Abtrieb) F _{qam} [N]	Betriebsfaktor f _s	Typ	Nennstrom [A]	Gewicht ~ [kg]	Maße Seite	Motor Effizienz- klasse
0,25 0,34	0,16	12585	9052,24	93983	1,2	KR876-3E71M/4C	0,67	648	196	IE3
	0,18	11054	7938,12	100294	1,4	KR876-2E71M/4B	0,71	647		IE2
	0,20	9787	7017,76	104980	1,5					
	0,24	8248	5902,70	109927	1,8					
	0,29	7025	5018,35	113658	2,1					
	0,33	6029	4299,81	116464	2,5					
	0,37	5462	3891,23	117976	2,7					
	0,42	4773	3396,71	119816	3,1					
	0,48	4214	2996,39	121167	3,6					
	0,54	3751	2665,68	122163	4,0					
0,60	3362	2387,89	126388	4,0						
0,20 0,22 0,26 0,32 0,36 0,41	9930	7156,22	41071	0,8	KR776-3E71M/4C	0,67	392	184	IE3	
	8858	6380,72	49391	0,9	KR776-2E71M/4B	0,71	391		IE2	
	7801	5610,63	55893	1,0						
	6287	4516,30	63529	1,3						
	5522	3960,44	66795	1,4						
	4889	3501,26	69254	1,6						
0,69 0,80	2961	2066,04	75548	2,7	KR775-3E71M/4C	0,67	392	184	IE3	
	2556	1786,65	76703	3,1	KR775-2E71M/4B	0,71	391		IE2	
0,37 0,42 0,50 0,59 0,69	5341	3844,04	13985	0,8	KR676-3E71M/4C	0,67	318	172	IE3	
	4729	3398,35	23714	0,9	KR676-2E71M/4B	0,71	317		IE2	
	3986	2858,39	31305	1,1						
	3395	2430,14	35760	1,3						
	2914	2082,19	38846	1,5						
0,77 0,90 1,0 1,2 1,4 1,6	2679	1875,03	40199	1,6	KR675-3E71M/4C	0,67	316	172	IE3	
	2278	1597,25	42315	1,9	KR675-2E71M/4B	0,71	315		IE2	
	1961	1373,07	43773	2,2						
	1703	1191,60	44927	2,5						
	1490	1041,68	45867	2,9						
	1311	915,75	46541	3,3						
0,64 0,76 1,0 1,2 1,5 1,8	3169	2236,28	16952	0,9	KR575-3E71M/4C	0,67	156	160	IE3	
	2681	1890,04	22886	1,0	KR575-2E71M/4B	0,71	155		IE2	
	1942	1368,95	28913	1,4						
	1727	1216,74	30365	1,6						
	1327	932,00	32610	2,0						
	1123	787,70	33654	2,4						
2,0 2,3	1060	469,74	33992	2,5	KR574-3E71M/6D	0,77	164	156	IE3	
	897	397,01	34694	3,0	KR574-2E71M/6C	0,78	163		IE2	
1,0 1,2 1,3 1,5 1,6 1,7	1981	1395,04	11495	0,8	KR475-3E71M/4C	0,67	113	148	IE3	
	1733	1218,61	14733	0,9	KR475-2E71M/4B	0,71	112		IE2	
	1627	1142,99	15892	1,0						
	1384	971,77	18047	1,1						
	1286	901,03	18816	1,2						
	1204	844,06	19393	1,3						
2,0 2,2 2,5	1067	472,63	20346	1,5	KR474-3E71M/6D	0,77	118	144	IE3	
	954	422,88	21045	1,6	KR474-2E71M/6C	0,78	117		IE2	
	839	371,35	21708	1,8						
3,0 3,4	691	472,63	22459	2,2	KR474-3E71M/4C	0,67	98	144	IE3	
	618	422,88	22819	2,5	KR474-2E71M/4B	0,71	97		IE2	

*: IE2 ve IE3 motorlu redüktör fiyatları farklıdır. / Geared motor prices are different for IE2 and IE3 motors. / Preise von Getrieben mit IE2 und IE3 Motoren sind unterschiedlich.

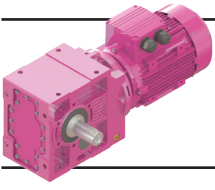

K Serisi Motorlu Güç Devir Sayfaları

K Series Geared Motors Performance Tables

K Serien Getriebemotoren Leistung und Drehzahlübersicht

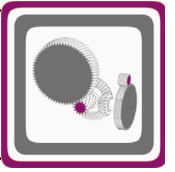

Güç	IE3 Çıkış Devri	IE3 Çıkış Momenti	Çevrim Oranı	IE3 Güv. Rad. Yük Çıkış	IE3 Servis Faktörü	Tipi	Anma Akımı	Ağırlık	Ölçü Sayfası	Motor Verim Snf.*
Power	Output Speeds	Output Torque	Ratio	Per.O. Loads (Output)	Service Factors	Type	Rated Current	Weight	Dim. Page	Motor Eff. Class
Leistung P _g [kW] P _g [HP]	Abtriebswelle Drehzahlen n ₂ [r.p.m]	Abtriebswelle Drehmomente M ₂ [Nm]	Übersetzung i	Zul.Querkräfte (Abtrieb) F _{qam} [N]	Betriebsfaktor f _s	Typ	Nennstrom [A]	Gewicht ~ [kg]	Maße Seite	Motor Effizienz-klasse
0,25 0,34	3,9	544	371,35	23170	2,9	KR474-3E71M/4C	0,67	98	144	IE3
	4,6	455	310,16	23565	3,4	KR474-2E71M/4B	0,71	97		IE2
	2,1	985	692,22	9709	0,8	KR375-3E71M/4C	0,67	72	136	IE3
	2,4	844	593,11	11751	1,0	KR375-2E71M/4B	0,71	71		IE2
	2,5	829	367,43	11952	1,0	KR374-3E71M/6D	0,77	64	132	IE3
	3,1	667	295,76	13705	1,2	KR374-2E71M/6C	0,78	63		IE2
	3,6	586	259,36	14452	1,4					
	3,9	537	367,43	14862	1,5	KR374-3E71M/4C	0,67	64	132	IE3
	4,9	432	295,76	15638	1,9	KR374-2E71M/4B	0,71	63		IE2
	5,5	380	259,36	16006	2,2					
	6,3	342	148,75	16244	2,4	KR373-3E71M/6D	0,77	59	128	IE3
	7,3	293	127,30	16551	2,8	KR373-2E71M/6C	0,78	58		IE2
	8,4	255	110,61	16778	3,2					
	3,3	641	284,33	15743	0,9	KR284-3E71M/6D	0,77	48	120	IE3
	3,7	563	249,33	16265	1,1	KR284-2E71M/6C	0,78	47		IE2
	4,1	516	353,22	16555	1,2	KR284-3E71M/4C	0,67	47	120	IE3
	5,0	415	284,33	17122	1,4	KR284-2E71M/4B	0,71	46		IE2
	5,8	365	249,33	17382	1,6					
	6,5	329	143,00	17555	1,8	KR283-3E71M/6D	0,77	37	116	IE3
	7,6	282	122,38	17770	2,1	KR283-2E71M/6C	0,78	36		IE2
	8,7	245	106,33	17928	2,4					
	4,0	514	360,73	11610	0,9	KR275-3E71M/4C	0,67	34	112	IE3
	4,8	429	300,85	12197	1,0	KR275-2E71M/4B	0,71	33		IE2
	5,7	360	252,20	12602	1,3					
	6,6	309	215,91	12885	1,5					
	7,2	287	200,35	12999	1,6					
	8,2	262	113,65	13120	1,7	KR273-3E71M/6D	0,77	24	108	IE3
	9,6	223	96,68	13304	2,0	KR273-2E71M/6C	0,78	23		IE2
	11	193	83,48	13438	2,3					
	13	169	113,65	13539	2,7	KR273-3E71M/4C	0,67	32	108	IE3
	15	144	96,68	13640	3,1	KR273-2E71M/4B	0,71	31		IE2
	17	125	83,48	13715	3,6					
	20	109	72,92	13811	4,0					
	6,7	329	138,53	5687	0,9	KR203-3E71M/6D	0,77	30	104	IE3
	7,8	284	119,62	7369	1,0	KR203-2E71M/6C	0,78	29		IE2
	8,9	249	104,49	8343	1,1					
	9,5	233	98,01	8691	1,2					
	10	213	138,53	9100	1,3	KR203-3E71M/4C	0,67	29	104	IE3
	12	184	119,62	8885	1,5	KR203-2E71M/4B	0,71	28		IE2
	14	161	104,49	8634	1,7					
	15	151	98,01	8512	1,9					
	17	129	83,32	8200	2,2					

*: IE2 ve IE3 motorlu redüktör fiyatları farklıdır. / Geared motor prices are different for IE2 and IE3 motors. / Preise von Getrieben mit IE2 und IE3 Motoren sind unterschiedlich.

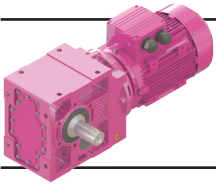

K Serisi Motorlu Güç Devir Sayfaları

K Series Geared Motors Performance Tables

K Serien Getriebemotoren Leistung und Drehzahlübersicht

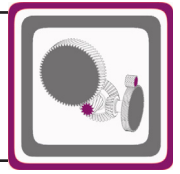

Güç	IE3 Çıkış Devri	IE3 Çıkış Momenti	Çevrim Oranı	IE3 Güv. Rad. Yük Çıkış	IE3 Servis Faktörü	Tipi	Anma Akımı	Ağırlık	Ölçü Sayfası	Motor Verim Snf.*
Power	Output Speeds	Output Torque	Ratio	Per. O. Loads (Output)	Service Factors	Type	Rated Current	Weight	Dim. Page	Motor Eff. Class
Leistung P _g [kW] P _g [HP]	Abtriebswelle Drehzahlen n ₂ [r.p.m]	Abtriebswelle Drehmomente M ₂ [Nm]	Übersetzung i	Zul.Querkräfte (Abtrieb) F _{qam} [N]	Betriebsfaktor f _s	Typ	Nennstrom [A]	Gewicht ~ [kg]	Maße Seite	Motor Effizienz-klasse
0,25 0,34	20	112	72,37	7923	2,5	KR203-3E71M/4C	0,67	29	104	IE3
	23	98	63,33	7660	2,9	KR203-2E71M/4B	0,71	28		IE2
	27	81	52,37	7287	3,5					
	12	179	116,34	4438	0,8	KR103-3E71M/4C	0,67	16	100	IE3
	14	162	105,26	5147	0,9	KR103-2E71M/4B	0,71	15		IE2
	16	137	88,87	5917	1,0					
	19	117	76,13	6381	1,2					
	21	104	67,22	6648	1,4					
	23	97	62,79	6765	1,4					
	27	82	53,07	6580	1,7					
	32	68	44,32	6290	2,0					
	38	59	38,22	6052	2,3					
	41	54	35,22	5922	2,5					
	44	51	32,90	5814	2,6					
	52	43	27,81	5551	2,9					
	56	40	25,50	6012	3,0	KR102-3E71M/4C	0,67	16	100	IE3
	68	33	21,25	5638	3,5	KR102-2E71M/4B	0,71	15		IE2
	75	30	19,13	5434	3,7					
21	104	67,44	2913	0,8	KR003-3E71M/4C	0,67	16	96	IE3	
25	88	57,16	3732	0,9	KR003-2E71M/4B	0,71	15		IE2	
29	75	48,93	4200	1,1						
32	70	45,41	4366	1,1						
41	55	35,34	4498	1,5						
48	46	29,95	4334	1,7						
56	40	25,64	4176	2,0						
60	37	23,79	4100	2,2						
72	31	19,88	3912	2,6	KR002-3E71M/4C	0,67	15	96	IE3	
89	25	16,18	3704	3,0	KR002-2E71M/4B	0,71	14		IE2	
97	23	14,73	3610	3,2						
108	21	13,26	3507	3,6						
129	17	11,09	3334	4,0						
153	15	9,40	3178	4,0						
178	13	8,04	3036	4,0						
192	12	7,46	2970	4,0						
193	12	14,73	2969	4,0	KR002-G63/2b	0,67	15	96	IE1	
214	10	13,26	2877	4,0						
256	8,7	11,09	2725	4,0						
302	7,4	9,40	2590	4,0						
353	6,3	8,04	2469	4,0						
380	5,8	7,46	2412	4,0						
0,37 0,50	0,14	22198	6741,12	68563	0,9	KR976-3E80M/6B	1,03	1100	208	IE3
	0,17	17632	5350,83	78718	1,1	KR976-2E80M/6A	1,08	1098		IE2
	0,22	13835	4189,63	85543	1,4					
	0,27	11582	3499,30	89007	1,7					
	0,28	10950	3306,00	89904	1,8					
	0,33	9323	2811,23	92132	2,1					
	0,40	7807	2348,01	93967	2,6					
	0,42	7381	2218,31	94484	2,7					
	0,47	6611	1985,89	95380	3,0					
	0,59	5383	1585,92	96726	3,7	KR975-3E80M/6B	1,03	1095	208	IE3
	0,65	4836	1423,89	97895	4,0	KR975-2E80M/6A	1,08	1093		IE2

*: IE2 ve IE3 motorlu redüktör fiyatları farklıdır. / Geared motor prices are different for IE2 and IE3 motors. / Preise von Getrieben mit IE2 und IE3 Motoren sind unterschiedlich.

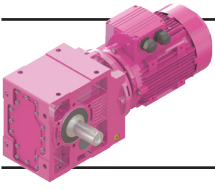

K Serisi Motorlu Güç Devir Sayfaları

K Series Geared Motors Performance Tables

K Serien Getriebemotoren Leistung und Drehzahlübersicht

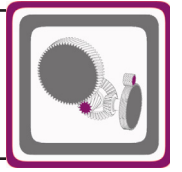

Güç	IE3 Çıkış Devri	IE3 Çıkış Momenti	Çevrim Oranı	IE3 Güv. Rad. Yük Çıkış	IE3 Servis Faktörü	Tipi	Anma Akımı	Ağırlık	Ölçü Sayfası	Motor Verim Snf.*
Power	Output Speeds	Output Torque	Ratio	Per.O. Loads (Output)	Service Factors	Type	Rated Current	Weight	Dim. Page	Motor Eff. Class
Leistung P _g [kW] P _g [HP]	Abtriebswelle Drehzahlen n ₂ [r.p.m]	Abtriebswelle Drehmomente M ₂ [Nm]	Übersetzung i	Zul.Querkräfte (Abtrieb) F _{qam} [N]	Betriebsfaktor f _s	Typ	Nennstrom [A]	Gewicht ~ [kg]	Maße Seite	Motor Effizienz-klasse
0,37 0,50	0,24	12585	5902,70	93986	1,2	KR876-3E71M/4D	0,97	648	196	IE3
	0,29	10719	5018,35	101578	1,4	KR876-2E71M/4C	1,00	647		IE2
	0,33	9199	4299,81	107005	1,6					
	0,37	8334	3891,23	109836	1,8					
	0,42	7282	3396,71	112900	2,1					
	0,48	6429	2996,39	115362	2,3					
	0,54	5723	2665,68	117288	2,6					
	0,60	5130	2387,89	118834	2,9					
	0,69	4453	2074,42	120596	3,4					
		0,76	4136	1891,08	121282	3,6	KR875-3E71M/4D	0,97	646	196
	0,86	3661	1671,18	123252	4,0	KR875-2E71M/4C	1,00	645		IE2
	0,96	3276	1495,27	127227	4,0					
	0,32	9593	4516,30	43792	0,8	KR776-3E71M/4D	0,97	390	184	IE3
	0,36	8426	3960,44	52309	0,9	KR776-2E71M/4C	1,00	389		IE2
	0,41	7460	3501,26	57772	1,1					
	0,69	4518	2066,04	70492	1,8	KR775-3E71M/4D	0,97	388	184	IE3
	0,80	3900	1786,65	72622	2,1	KR775-2E71M/4C	1,00	387		IE2
	0,93	3380	1547,01	74285	2,4					
	1,1	2959	1353,02	75554	2,7					
	1,2	2611	1192,77	76552	3,1					
	0,59	5180	2430,14	17163	0,8	KR676-3E71M/4D	0,97	251	172	IE3
	0,69	4446	2082,19	26845	1,0	KR676-2E71M/4C	1,00	250		IE2
	0,77	4088	1875,03	30390	1,1	KR675-3E71M/4D	0,97	247	172	IE3
	0,90	3476	1597,25	35191	1,2	KR675-2E71M/4C	1,00	246		IE2
	1,0	2991	1373,07	38300	1,4					
	1,2	2598	1191,60	40646	1,7					
	1,4	2273	1041,68	42341	1,9					
	1,6	2000	915,75	43590	2,2					
	1,8	1770	809,27	44633	2,4					
	2,0	1584	724,08	45432	2,7					
	2,3	1394	635,86	46212	3,1					
	1,0	2963	1368,95	19659	0,9	KR575-3E71M/4D	0,97	186	160	IE3
	1,2	2635	1216,74	23352	1,0	KR575-2E71M/4C	1,00	184		IE2
	1,5	2025	932,00	28381	1,3					
	1,8	1713	787,70	30450	1,6					
	2,0	1618	469,74	31010	1,7	KR574-3E80M/6B	1,03	161	156	IE3
	2,3	1369	397,01	32395	2,0	KR574-2E80M/6A	1,08	160		IE2
	2,8	1136	328,56	33599	2,4					
	3,1	1049	469,74	34013	2,6	KR574-3E71M/4D	0,97	153	156	IE3
	3,6	887	397,01	34755	3,0	KR574-2E71M/4C	1,00	152		IE2
	2,0	1628	472,63	15838	1,0	KR474-3E80M/6B	1,03	100	144	IE3
	2,2	1456	422,88	17441	1,1	KR474-2E80M/6A	1,08	99		IE2
	2,5	1280	371,35	18861	1,2					
	3,0	1055	472,63	20423	1,5	KR474-3E71M/4D	0,97	98	144	IE3
	3,4	944	422,88	21109	1,6	KR474-2E71M/4C	1,00	97		IE2
	3,9	830	371,35	21728	1,9					

*: IE2 ve IE3 motorlu redüktör fiyatları farklıdır. / Geared motor prices are different for IE2 and IE3 motors. / Preise von Getrieben mit IE2 und IE3 Motoren sind unterschiedlich.

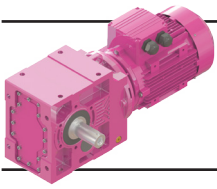

K Serisi Motorlu Güç Devir Sayfaları

K Series Geared Motors Performance Tables

K Serien Getriebemotoren Leistung und Drehzahlübersicht

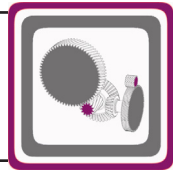

Güç	IE3 Çıkış Devri	IE3 Çıkış Momenti	Çevrim Oranı	IE3 Güv. Rad. Yük Çıkış	IE3 Servis Faktörü	Tipi	Anma Akımı	Ağırlık	Ölçü Sayfası	Motor Verim Snf.*	
Power	Output Speeds	Output Torque	Ratio	Per. O. Loads (Output)	Service Factors	Type	Rated Current	Weight	Dim. Page	Motor Eff. Class	
Leistung P _g [kW] P _g [HP]	Abtriebswelle Drehzahlen n ₂ [r.p.m]	Abtriebswelle Drehmomente M ₂ [Nm]	Übersetzung i	Zul.Querkräfte (Abtrieb) F _{qam} [N]	Betriebsfaktor f _s	Typ	Nennstrom [A]	Gewicht ~ [kg]	Maße Seite	Motor Effizienz- klasse	
0,37 0,50	4,6	694	310,16	22447	2,2	KR474-3E71M/4D	0,97	98	144	IE3	
	4,9	656	293,03	22637	2,4	KR474-2E71M/4C	1,00	97		IE2	
	6,1	540	153,47	23177	2,9	KR473-3E80M/6B	1,03	93	140	IE3	
	6,8	478	135,98	23477	3,2	KR473-2E80M/6A	1,08	92		IE2	
	8,4	390	110,65	23849	4,0						
	3,1	1018	295,76	9149	0,8	KR374-3E80M/6B	1,03	66	132	IE3	
	3,6	894	259,36	11098	0,9	KR374-2E80M/6A	1,08	65		IE2	
	3,9	819	367,43	12058	1,0						
	4,9	660	295,76	13757	1,2						
	5,5	579	259,36	14509	1,4						
	6,3	513	229,29	15058	1,6						
	7,3	447	127,30	15535	1,8	KR373-3E80M/6B	1,03	62	128	IE3	
	8,4	389	110,61	15946	2,1	KR373-2E80M/6A	1,08	61		IE2	
	9,6	339	148,75	16272	2,4	KR373-3E71M/4D	0,97	60	128	IE3	
	11	291	127,30	16574	2,8	KR373-2E71M/4C	1,00	59		IE2	
	13	253	110,61	16807	3,2						
	5,0	634	284,33	15791	0,9	KR284-3E71M/4D	0,97	48	120	IE3	
	5,8	556	249,33	16305	1,1	KR284-2E71M/4C	1,00	47		IE2	
	6,5	492	220,43	16694	1,2						
	7,7	415	185,40	17126	1,4						
	8,7	374	106,33	17337	1,6	KR283-3E80M/6B	1,03	40	116	IE3	
						KR283-2E80M/6A	1,08	39		IE2	
	10	326	143,00	17569	1,8	KR283-3E71M/4D	0,97	38	116	IE3	
	12	279	122,38	17781	2,1	KR283-2E71M/4C	1,00	37		IE2	
	14	243	106,33	17938	2,5						
	15	214	93,50	18036	2,8						
	19	172	75,26	18203	3,5						
	22	151	66,00	18284	4,0						
	4,8	654	300,85	10434	0,7	KR275-3E71M/4D	0,97	34	112	IE3	
	5,7	549	252,20	11342	0,8	KR275-2E71M/4C	1,00	33		IE2	
	6,6	471	215,91	11916	1,0						
	7,2	438	200,35	12141	1,0						
	9,6	340	96,68	12719	1,3	KR273-3E80M/6B	1,03	44	108	IE3	
	11	294	83,48	12966	1,5	KR273-2E80M/6A	1,08	43		IE2	
	13	259	113,65	13136	1,7	KR273-3E71M/4D	0,97	34	108	IE3	
	15	221	96,68	13317	2,0	KR273-2E71M/4C	1,00	33		IE2	
	17	191	83,48	13449	2,4						
	20	167	72,92	13549	2,7						
	21	157	68,40	13591	2,9						
	25	133	58,15	13683	3,4						
	28	116	50,51	13749	3,9						
	32	101	44,20	13953	4,0						
		9,5	345	98,01	4860	0,8	KR203-3E80M/6B	1,03	33	104	IE3
							KR203-2E80M/6A	1,08	32		IE2

*: IE2 ve IE3 motorlu redüktör fiyatları farklıdır. / Geared motor prices are different for IE2 and IE3 motors. / Preise von Getrieben mit IE2 und IE3 Motoren sind unterschiedlich.

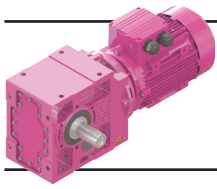

K Serisi Motorlu Güç Devir Sayfaları

K Series Geared Motors Performance Tables

K Serien Getriebemotoren Leistung und Drehzahlübersicht

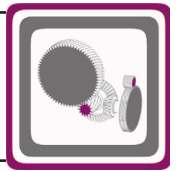

Güç	IE3 Çıkış Devri	IE3 Çıkış Momenti	Çevrim Oranı	IE3 Güv. Rad. Yük Çıkış	IE3 Servis Faktörü	Tipi	Anma Akımı	Ağırlık	Ölçü Sayfası	Motor Verim Snf.*
Power	Output Speeds	Output Torque	Ratio	Per.O. Loads (Output)	Service Factors	Type	Rated Current	Weight	Dim. Page	Motor Eff. Class
Leistung P _g [kW] P _g [HP]	Abtriebswelle Drehzahlen n ₂ [r.p.m]	Abtriebswelle Drehmomente M ₂ [Nm]	Übersetzung i	Zul.Querkräfte (Abtrieb) F _{qam} [N]	Betriebsfaktor f _s	Typ	Nennstrom [A]	Gewicht ~ [kg]	Maße Seite	Motor Effizienz-klasse
0,37 0,50	10	316	138,53	6243	0,9	KR203-3E71M/4D	0,97	30	104	IE3
	12	273	119,62	7697	1,0	KR203-2E71M/4C	1,00	29		IE2
	14	239	104,49	7890	1,2					
	15	224	98,01	7817	1,2					
	17	191	83,32	7616	1,5					
	20	166	72,37	7420	1,7					
	23	145	63,33	7223	1,9					
	27	120	52,37	6929	2,3					
	33	100	43,67	6640	2,8					
	38	88	38,16	6424	3,2					
	19	174	76,13	4642	0,8	KR103-3E71M/4D	0,97	17	100	IE3
	21	154	67,22	5410	0,9	KR103-2E71M/4C	1,00	16		IE2
	23	144	62,79	5721	1,0					
	27	121	53,07	6138	1,2					
	32	102	44,32	5925	1,4					
	38	88	38,22	5740	1,5					
	41	81	35,22	5636	1,7					
	44	76	32,90	5548	1,7					
	52	64	27,81	5328	2,0					
		56	59	25,50	6095	2,0	KR102-3E71M/4D	0,97	17	100
68		49	21,25	5709	2,3	KR102-2E71M/4C	1,00	16		IE2
75		44	19,13	5498	2,5					
83		40	17,30	5306	2,7					
98		34	14,61	4997	3,2					
	32	104	45,41	2897	0,8	KR003-3E71M/4D	0,97	16	96	IE3
	41	81	35,34	4010	1,0	KR003-2E71M/4C	1,00	15		IE2
	48	69	29,95	4004	1,2					
	56	59	25,64	3897	1,4					
	60	55	23,79	3842	1,5					
	72	46	19,88	3696	1,7	KR002-3E71M/4D	0,97	16	96	IE3
	89	38	16,18	3530	2,0	KR002-2E71M/4C	1,00	15		IE2
	97	34	14,73	3453	2,2					
	108	31	13,26	3366	2,4					
	129	26	11,09	3217	2,9					
	153	22	9,40	3080	3,2					
	178	19	8,04	2952	3,5					
	192	17	7,46	2892	3,7					
	192	17	14,73	2894	3,5	KR002-3E71M/2B	0,86	15	96	IE3
	213	16	13,26	2810	3,9	KR002-2E71M/2A	0,90	14		IE2
	255	13	11,09	2670	4,0					
	301	11	9,40	2544	4,0					
	352	9,5	8,04	2430	4,0					
	379	8,8	7,46	2376	4,0					
0,55 0,75	0,22	21164	6741,12	71126	0,9	KR976-3E80M/4C	1,34	1105	208	IE3
	0,27	16810	5350,83	80281	1,2	KR976-2E80M/4B	1,45	1103		IE2
	0,35	13191	4189,63	86503	1,5					
	0,41	11042	3499,30	89577	1,8					
	0,44	10439	3306,00	90570	1,9					
	0,52	8889	2811,23	92516	2,3					
	0,62	7443	2348,01	94410	2,7					
	0,65	7037	2218,31	94891	2,8					
	0,73	6303	1985,89	95727	3,2					

*: IE2 ve IE3 motorlu redüktör fiyatları farklıdır. / Geared motor prices are different for IE2 and IE3 motors. / Preise von Getrieben mit IE2 und IE3 Motoren sind unterschiedlich.

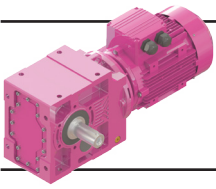

K Serisi Motorlu Güç Devir Sayfaları

K Series Geared Motors Performance Tables

K Serien Getriebemotoren Leistung und Drehzahlübersicht

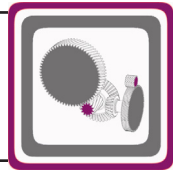

Güç	IE3 Çıkış Devri	IE3 Çıkış Momenti	Çevrim Oranı	IE3 Güv. Rad. Yük Çıkış	IE3 Servis Faktörü	Tipi	Anma Akımı	Ağırlık	Ölçü Sayfası	Motor Verim Sınıfı*	
Power	Output Speeds	Output Torque	Ratio	Per. O. Loads (Output)	Service Factors	Type	Rated Current	Weight	Dim. Page	Motor Eff. Class	
Leistung P _g [kW] P _g [HP]	Abtriebswelle Drehzahlen n ₂ [r.p.m]	Abtriebswelle Drehmomente M ₂ [Nm]	Übersetzung i	Zul. Querkräfte (Abtrieb) F _{qam} [N]	Betriebsfaktor f _s	Typ	Nennstrom [A]	Gewicht ~ [kg]	Maße Seite	Motor Effizienz-klasse	
0,55 0,75	0,91	5132	1585,92	96993	3,9	KR975-3E80M/4C	1,34	1100	208	IE3	
	1,0	4611	1423,89	99024	4,0	KR975-2E80M/4B	1,45	1098		IE2	
0,43 0,48 0,54 0,61 0,70	0,43	10713	3396,71	101600	1,4	KR876-3E80M/4C	1,34	655	196	IE3	
	0,48	9458	2996,39	106126	1,6	KR876-2E80M/4B	1,45	654		IE2	
	0,54	8419	2665,68	109566	1,8						
	0,61	7546	2387,89	112266	2,0						
	0,70	6550	2074,42	115149	2,3						
0,77 0,87 0,97 1,1 1,3 1,5	0,77	6084	1891,08	116259	2,5	KR875-3E80M/4C	1,34	651	196	IE3	
	0,87	5385	1671,18	118129	2,8	KR875-2E80M/4B	1,45	650		IE2	
	0,97	4820	1495,27	119576	3,1						
	1,1	4240	1313,07	121000	3,5						
	1,3	3549	1096,71	124461	4,0						
	1,5	3102	957,34	128847	4,0						
0,70 0,81 0,94 1,1 1,2 1,4 1,5 1,7 1,9	0,70	6646	2066,04	61869	1,2	KR775-3E80M/4C	1,34	393	184	IE3	
	0,81	5737	1786,65	65911	1,4	KR775-2E80M/4B	1,45	392		IE2	
	0,94	4973	1547,01	68941	1,6						
	1,1	4353	1353,02	71183	1,8						
	1,2	3840	1192,77	72906	2,1						
	1,4	3409	1058,16	74160	2,3						
	1,5	3042	943,49	75280	2,6						
	1,7	2693	833,78	76295	3,0						
	1,9	2410	746,01	77083	3,3						
0,91 1,1 1,2 1,4 1,6 1,8 2,0 2,3	0,91	5114	1597,25	18299	0,8	KR675-3E80M/4C	1,34	320	172	IE3	
	1,1	4401	1373,07	27374	1,0	KR675-2E80M/4B	1,45	319		IE2	
	1,2	3822	1191,60	32584	1,1						
	1,4	3344	1041,68	36109	1,3						
	1,6	2942	915,75	38680	1,5						
	1,8	2604	809,27	40614	1,7						
	2,0	2331	724,08	42051	1,8						
	2,3	2051	635,86	43418	2,1						
2,6 2,9 3,4 4,0	2,6	1867	363,81	44261	2,3	KR674-3E80M/6C	1,47	206	168	IE3	
	2,9	1652	321,51	45193	2,6	KR674-2E80M/6B	1,50	205		IE2	
	3,4	1406	273,88	46204	3,1						
	4,0	1210	235,44	46959	3,6						
1,6 1,8	1,6	2979	932,00	19523	0,9	KR575-3E80M/4C	1,34	154	160	IE3	
	1,8	2521	787,70	24386	1,1	KR575-2E80M/4B	1,45	153		IE2	
2,0 2,4 2,8	2,0	2392	469,74	25521	1,1	KR574-3E80M/6C	1,47	158	156	IE3	
	2,4	2025	397,01	28384	1,3	KR574-2E80M/6B	1,50	157		IE2	
	2,8	1680	328,56	30658	1,6						
3,1 3,7 4,4 5,2 5,9	3,1	1543	469,74	31472	1,8	KR574-3E80M/4C	1,34	155	156	IE3	
	3,7	1305	397,01	32773	2,1	KR574-2E80M/4B	1,45	154		IE2	
	4,4	1083	328,56	33884	2,5						
	5,2	927	281,00	34563	2,9						
	5,9	814	246,42	35063	3,3						
2,5	2,5	1893	371,35	12782	0,8	KR474-3E80M/6C	1,47	102	144	IE3	
						KR474-2E80M/6B	1,45	101		IE2	

*: IE2 ve IE3 motorlu redüktör fiyatları farklıdır. / Geared motor prices are different for IE2 and IE3 motors. / Preise von Getrieben mit IE2 und IE3 Motoren sind unterschiedlich.

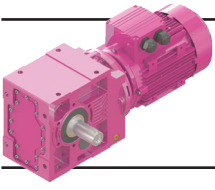

K Serisi Motorlu Güç Devir Sayfaları

K Series Geared Motors Performance Tables

K Serien Getriebemotoren Leistung und Drehzahlübersicht

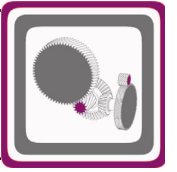

Güç	IE3 Çıkış Devri	IE3 Çıkış Momenti	Çevrim Oranı	IE3 Güv. Rad. Yük Çıkış	IE3 Servis Faktörü	Tipi	Anma Akımı	Ağırlık	Ölçü Sayfası	Motor Verim Snf.*
Power	Output Speeds	Output Torque	Ratio	Per.O. Loads (Output)	Service Factors	Type	Rated Current	Weight	Dim. Page	Motor Eff. Class
Leistung P _g [kW] P _g [HP]	Abtriebswelle Drehzahlen n ₂ [r.p.m]	Abtriebswelle Drehmomente M ₂ [Nm]	Übersetzung i	Zul.Querkräfte (Abtrieb) F _{qam} [N]	Betriebsfaktor f _s	Typ	Nennstrom [A]	Gewicht ~ [kg]	Maße Seite	Motor Effizienz-klasse
0,55 0,75	3,1	1552	472,63	16587	1,0	KR474-3E80M/4C	1,34	101	144	IE3
	3,4	1388	422,88	18011	1,1	KR474-2E80M/4B	1,45	100		IE2
	3,9	1220	371,35	19300	1,3					
	4,7	1021	310,16	20640	1,5					
	4,9	965	293,03	20983	1,6					
	6,1	800	153,47	21919	1,9	KR473-3E80M/6C	1,47	94	140	IE3
	6,9	709	135,98	22395	2,2	KR473-2E80M/6B	1,50	93		IE2
	8,4	578	110,65	23030	2,7					
	9,4	517	153,47	23280	3,0	KR473-3E80M/4C	1,34	94	140	IE3
	11	458	135,98	23565	3,4	KR473-2E80M/4B	1,45	93		IE2
	13	373	110,65	24142	4,0					
	4,9	971	295,76	9956	9956	0,8	KR374-3E80M/4C	1,34	67	132
5,6	852	259,36	11651	11651	1,0	KR374-2E80M/4B	1,45	66		IE2
6,3	754	229,29	12812	12812	1,1					
7,3	663	127,30	13748	13748	1,2	KR373-3E80M/6C	1,47	64	128	IE3
8,5	577	110,61	14514	14514	1,4	KR373-2E80M/6B	1,50	63		IE2
9,6	508	97,26	16830	16830	1,6					
11	428	127,30	15691	15691	1,9	KR373-3E80M/4C	1,34	63	128	IE3
13	372	110,61	16072	16072	2,2	KR373-2E80M/4B	1,45	62		IE2
15	328	97,26	16338	16338	2,5					
19	264	78,29	16727	16727	3,1					
6,6	724	220,43	15122	15122	0,8	KR284-3E80M/4C	1,34	51	120	IE3
7,8	610	185,40	15962	15962	1,0	KR284-2E80M/4B	1,45	50		IE2
8,8	554	106,33	16320	16320	1,1	KR283-3E80M/6C	1,47	41	116	IE3
10	488	93,50	16830	16830	1,2	KR283-2E80M/6B	1,50	40		IE2
12	393	75,26	17241	17241	1,5					
14	358	106,33	17416	17416	1,7	KR283-3E80M/4C	1,34	41	116	IE3
16	315	93,50	17620	17620	1,9	KR283-2E80M/4B	1,45	40		IE2
19	254	75,26	17892	17892	2,4					
22	223	66,00	18021	18021	2,7					
25	197	58,35	18124	18124	3,0					
30	166	49,08	18243	18243	3,6					
7,2	644	200,35	10534	10534	0,7	KR275-3E80M/4C	1,34	38	112	IE3
						KR275-2E80M/4B	1,45	37		IE2
9,7	504	96,68	11685	11685	0,9	KR273-3E80M/6C	1,47	35	108	IE3
11	435	83,48	12163	12163	1,0	KR273-2E80M/6B	1,50	34		IE2
13	381	72,92	12494	12494	1,2					
15	325	96,68	12809	12809	1,4	KR273-3E80M/4C	1,34	37	108	IE3
17	281	83,48	13023	13023	1,6	KR273-2E80M/4B	1,45	36		IE2
20	246	72,92	13197	13197	1,8					
21	231	68,40	13268	13268	1,9					
25	196	58,15	13423	13423	2,3					
29	171	50,51	13532	13532	2,6					

*: IE2 ve IE3 motorlu redüktör fiyatları farklıdır. / Geared motor prices are different for IE2 and IE3 motors. / Preise von Getrieben mit IE2 und IE3 Motoren sind unterschiedlich.

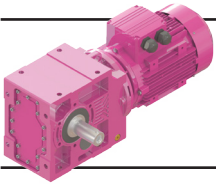

K Serisi Motorlu Güç Devir Sayfaları

K Series Geared Motors Performance Tables

K Serien Getriebemotoren Leistung und Drehzahlübersicht

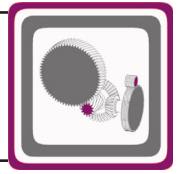

Güç	IE3 Çıkış Devri	IE3 Çıkış Momenti	Çevrim Oranı	IE3 Güv. Rad. Yük Çıkış	IE3 Servis Faktörü	Tipi	Anma Akımı	Ağırlık	Ölçü Sayfası	Motor Verim Snf.*	
Power	Output Speeds	Output Torque	Ratio	Per.O. Loads (Output)	Service Factors	Type	Rated Current	Weight	Dim. Page	Motor Eff. Class	
Leistung P _g [kW] P _g [HP]	Abtriebswelle Drehzahlen n ₂ [r.p.m]	Abtriebswelle Drehmomente M ₂ [Nm]	Übersetzung i	Zul.Querkräfte (Abtrieb) F _{qam} [N]	Betriebsfaktor f _s	Typ	Nennstrom [A]	Gewicht ~ [kg]	Maße Seite	Motor Effizienz- klasse	
0,55 0,75	33	149	44,20	13618	3,0	KR273-3E80M/4C	1,34	37	108	IE3	
	40	124	36,55	13718	3,6	KR273-2E80M/4B	1,45	36		IE2	
	48	103	30,48	13923	4,0						
	14	352	104,49	4449	0,8	KR203-3E80M/4C	1,34	33	104	IE3	
	15	330	98,01	5626	0,8	KR203-2E80M/4B	1,45	32		IE2	
	17	281	83,32	6693	1,0						
	20	244	72,37	6625	1,1						
	23	214	63,33	6533	1,3						
	28	177	52,37	6363	1,6						
	33	148	43,67	6170	1,9						
38	129	38,16	6014	2,2							
46	107	31,55	5779	2,6							
55	89	26,31	5545	3,0							
61	82	23,79	6415	3,4		KR202-3E80M/4C	1,34	33	104	IE3	
						KR202-2E80M/4B	1,45	32		IE2	
	27	179	53,07	4428	0,8	KR103-3E80M/4C	1,34	20	100	IE3	
	33	150	44,32	5348	0,9	KR103-2E80M/4B	1,45	19		IE2	
	38	129	38,22	5246	1,0						
	41	119	35,22	5182	1,1						
	44	111	32,90	5125	1,2						
	52	94	27,81	4972	1,3						
	57	87	25,50	6186	1,4	KR102-3E80M/4C	1,34	20	100	IE3	
	68	73	21,25	5786	1,6	KR102-2E80M/4B	1,45	19		IE2	
76	66	19,13	5567	1,7							
84	59	17,30	5368	1,9							
99	50	14,61	5050	2,2							
116	43	12,51	4776	2,4							
131	38	11,05	4568	2,6							
140	35	10,32	4458	2,8							
166	30	8,72	4200	3,2							
48	101	29,95	3075	0,8		KR003-3E80M/4C	1,34	19	96	IE3	
	57	87	25,64	3454	0,9	KR003-2E80M/4B	1,45	18		IE2	
	61	80	23,79	3433	1,0						
	73	68	19,88	3355	1,2	KR002-3E80M/4C	1,34	19	96	IE3	
	90	55	16,18	3255	1,4	KR002-2E80M/4B	1,45	18		IE2	
	98	51	14,73	3203	1,5						
	109	45	13,26	3141	1,7						
	131	38	11,09	3029	2,0						
	154	32	9,40	2921	2,2						
	180	28	8,04	2816	2,3						
194	26	7,46	2765	2,5							
192	26	14,73	2775	2,3		KR002-3E71M/2C	1,19	16	96	IE3	
	213	23	13,26	2703	2,6	KR002-2E71M/2B	1,25	15		IE2	
	255	19	11,09	2581	3,1						
	301	17	9,40	2469	3,3						
	352	14	8,04	2366	3,9						
	379	13	7,46	2316	4,0						
	0,75 1,0	0,27	22923	5350,83	66697	0,9	KR976-3E80M/4D	1,77	1106	208	IE3
		0,35	17987	4189,63	78083	1,1	KR976-2E80M/4C	1,89	1104		IE2
		0,41	15057	3499,30	83385	1,3					

*: IE2 ve IE3 motorlu redüktör fiyatları farklıdır. / Geared motor prices are different for IE2 and IE3 motors. / Preise von Getrieben mit IE2 und IE3 Motoren sind unterschiedlich.

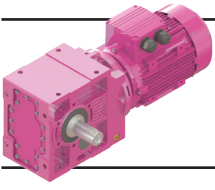

K Serisi Motorlu Güç Devir Sayfaları

K Series Geared Motors Performance Tables

K Serien Getriebemotoren Leistung und Drehzahlübersicht

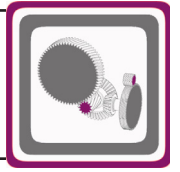

Güç	IE3 Çıkış Devri	IE3 Çıkış Momenti	Çevrim Oranı	IE3 Güv. Rad. Yük Çıkış	IE3 Servis Faktörü	Tipi	Anma Akımı	Ağırlık	Ölçü Sayfası	Motor Verim Snf.*
Power	Output Speeds	Output Torque	Ratio	Per.O. Loads (Output)	Service Factors	Type	Rated Current	Weight	Dim. Page	Motor Eff. Class
Leistung P _g [kW] P _g [HP]	Abtriebswelle Drehzahlen n ₂ [r.p.m]	Abtriebswelle Drehmomente M ₂ [Nm]	Übersetzung i	Zul.Querkräfte (Abtrieb) F _{qam} [N]	Betriebsfaktor f _s	Typ	Nennstrom [A]	Gewicht ~ [kg]	Maße Seite	Motor Effizienz-klasse
0,75 1,0	0,44	14236	3306,00	84954	1,4	KR976-3E80M/4D	1,77	1106	208	IE3
	0,52	12121	2811,23	88156	1,7	KR976-2E80M/4C	1,89	1104		IE2
	0,62	10149	2348,01	90949	2,0					
	0,65	9596	2218,31	91693	2,1					
	0,73	8595	1985,89	92986	2,3					
	0,91	6998	1585,92	94798	2,9	KR975-3E80M/4D	1,77	1101	208	IE3
	1,0	6287	1423,89	95673	3,2	KR975-2E80M/4C	1,89	1099		IE2
	1,2	5356	1213,78	96738	3,7					
	1,4	4726	1070,02	98524	4,0					
	0,48	12897	2996,39	92600	1,2	KR876-3E80M/4D	1,77	653	196	IE3
0,54	11481	2665,68	98610	1,3	KR876-2E80M/4C	1,89	651		IE2	
0,61	10290	2387,89	103170	1,5						
0,70	8932	2074,42	107899	1,7						
0,77 0,87 0,97 1,1 1,3 1,5 1,7 1,9	8296	1891,08	109774	1,8	KR875-3E80M/4D	1,77	651	196	IE3	
	7344	1671,18	112719	2,0	KR875-2E80M/4C	1,89	649		IE2	
	6572	1495,27	114961	2,3						
	5781	1313,07	117134	2,6						
	4840	1096,71	119567	3,1						
	4230	957,34	121059	3,5						
	3735	844,51	122416	4,0						
	3326	751,30	126745	4,0						
	0,70	9063	2066,04	47924	0,9	KR775-3E80M/4D	1,77	393	184	IE3
0,81	7823	1786,65	55767	1,0	KR775-2E80M/4C	1,89	391		IE2	
0,94	6781	1547,01	61224	1,2						
0,70	9108	1353,02	47716	0,9						
1,2	5237	1192,77	67929	1,5						
1,4	4649	1058,16	70135	1,7						
1,5	4148	943,49	71790	1,9						
1,7	3672	833,78	73367	2,2						
1,9	3286	746,01	74575	2,4						
2,2	2891	655,11	75752	2,8						
2,4 2,7 3,0	2751	396,00	76168	2,9	KR774-3E90S/6B	1,96	407	180	IE3	
	2462	354,32	76974	3,2	KR774-2E90S/6A	2,00	405		IE2	
	2166	311,14	77769	3,7						
1,2 1,4 1,6 1,8 2,0 2,3	5212	1191,60	16574	0,8	KR675-3E80M/4D	1,77	321	172	IE3	
	4560	1041,68	25595	0,9	KR675-2E80M/4C	1,89	319		IE2	
	4012	915,75	31082	1,1						
	3551	809,27	34652	1,2						
	3178	724,08	37206	1,4						
	2796	635,86	39536	1,5						
	2,6	2519	363,81	41003	1,7	KR674-3E90S/6B	1,96	301	168	IE3
2,9	2229	321,51	42498	1,9	KR674-2E90S/6A	2,00	209		IE2	
3,5	1897	273,88	44120	2,3						
4,0 4,5 5,3	1641	363,81	45192	2,6	KR674-3E80M/4D	1,77	296	168	IE3	
	1453	321,51	45975	3,0	KR674-2E80M/4C	1,89	294		IE2	
	1236	273,88	46829	3,5						

*: IE2 ve IE3 motorlu redüktör fiyatları farklıdır. / Geared motor prices are different for IE2 and IE3 motors. / Preise von Getrieben mit IE2 und IE3 Motoren sind unterschiedlich.

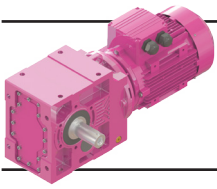

K Serisi Motorlu Güç Devir Sayfaları

K Series Geared Motors Performance Tables

K Serien Getriebemotoren Leistung und Drehzahlübersicht

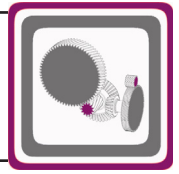

Güç	IE3 Çıkış Devri	IE3 Çıkış Momenti	Çevrim Oranı	IE3 Güv. Rad. Yük Çıkış	IE3 Servis Faktörü	Tipi	Anma Akımı	Ağırlık	Ölçü Sayfası	Motor Verim Snf.*
Power	Output Speeds	Output Torque	Ratio	Per. O. Loads (Output)	Service Factors	Type	Rated Current	Weight	Dim. Page	Motor Eff. Class
Leistung P _g [kW] P _g [HP]	Abtriebswelle Drehzahlen n ₂ [r.p.m]	Abtriebswelle Drehmomente M ₂ [Nm]	Übersetzung i	Zul.Querkräfte (Abtrieb) F _{qam} [N]	Betriebsfaktor f _s	Typ	Nennstrom [A]	Gewicht ~ [kg]	Maße Seite	Motor Effizienz- klasse
0,75 1,0	2,0	3228	469,74	15989	0,8	KR574-3E90S/6B	1,96	159	156	IE3
	2,4	2732	397,01	22409	1,0	KR574-2E90S/6A	2,00	157		IE2
	2,9	2266	328,56	26563	1,2					
	3,1	2104	469,74	27812	1,3	KR574-3E80M/4D	1,77	156	156	IE3
	3,7	1780	397,01	30031	1,5	KR574-2E80M/4C	1,89	154		IE2
	4,4	1477	328,56	31845	1,8					
	5,2	1264	281,00	32943	2,1					
	5,9	1110	246,42	33716	2,4					
	6,1	1071	237,97	33906	2,5					
	6,9	953	211,51	34460	2,8					
	3,4	1893	422,88	12714	0,8	KR474-3E80M/4D	1,77	103	144	IE3
	3,9	1664	371,35	15500	0,9	KR474-2E80M/4C	1,89	101		IE2
4,7	1392	310,16	17982	1,1						
4,9	1316	293,03	18590	1,2						
6,2	1079	153,47	20234	1,4	KR473-3E90S/6B	1,96	99	140	IE3	
6,9	956	135,98	21039	1,6	KR473-2E90S/6A	2,00	97		IE2	
8,5	779	110,65	22009	2,0						
9,4	706	153,47	22412	2,2	KR473-3E80M/4D	1,77	95	140	IE3	
11	625	135,98	22807	2,5	KR473-2E80M/4C	1,89	93		IE2	
13	510	110,65	23324	3,0						
15	451	97,79	23564	3,4						
6,3	1028	229,29	8932	0,8	KR374-3E80M/4D	1,77	68	132	IE3	
					KR374-2E80M/4C	1,89	66		IE2	
8,5	778	110,61	12550	1,1	KR373-3E90S/6B	1,96	68	128	IE3	
9,7	684	97,26	16200	1,2	KR373-2E90S/6A	2,00	66		IE2	
13	509	110,61	15090	1,6	KR373-3E80M/4D	1,77	64	128	IE3	
15	448	97,26	15527	1,8	KR373-2E80M/4C	1,89	62		IE2	
19	361	78,29	16133	2,3						
21	317	68,65	16415	2,6						
24	280	60,69	16637	2,9						
9,2	708	157,62	15248	0,8	KR284-3E80M/4D	1,77	52	120	IE3	
					KR284-2E80M/4C	1,89	51		IE2	
10	658	93,50	16200	0,9	KR283-3E90S/6B	1,96	45	116	IE3	
13	530	75,26	16472	1,1	KR283-2E90S/6A	2,00	44		IE2	
14	489	106,33	16717	1,2	KR283-3E80M/4D	1,77	42	116	IE3	
16	430	93,50	17044	1,4	KR283-2E80M/4C	1,89	41		IE2	
19	346	75,26	17471	1,7						
22	304	66,00	17670	2,0						
25	269	58,35	17826	2,2						
30	227	49,08	18005	2,6						
35	193	41,72	18140	3,1						
41	166	35,75	18245	3,6						

*: IE2 ve IE3 motorlu redüktör fiyatları farklıdır. / Geared motor prices are different for IE2 and IE3 motors. / Preise von Getrieben mit IE2 und IE3 Motoren sind unterschiedlich.

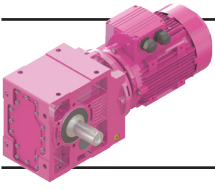

K Serisi Motorlu Güç Devir Sayfaları

K Series Geared Motors Performance Tables

K Serien Getriebemotoren Leistung und Drehzahlübersicht

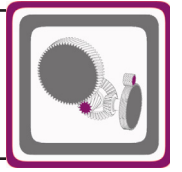

Güç	IE3 Çıkış Devri	IE3 Çıkış Momenti	Çevrim Oranı	IE3 Güv. Rad. Yük Çıkış	IE3 Servis Faktörü	Tipi	Anma Akımı	Ağırlık	Ölçü Sayfası	Motor Verim Snf.*	
Power	Output Speeds	Output Torque	Ratio	Per.O. Loads (Output)	Service Factors	Type	Rated Current	Weight	Dim. Page	Motor Eff. Class	
Leistung P _g [kW] P _g [HP]	Abtriebswelle Drehzahlen n ₂ [r.p.m]	Abtriebswelle Drehmomente M ₂ [Nm]	Übersetzung i	Zul.Querkräfte (Abtrieb) F _{qam} [N]	Betriebsfaktor f _s	Typ	Nennstrom [A]	Gewicht ~ [kg]	Maße Seite	Motor Effizienz-klasse	
0,75 1,0	11	587	83,48	11033	0,8	KR273-3E90S/6B	1,96	36	108	IE3	
	13	513	72,92	11614	0,9	KR273-2E90S/6A	2,00	38		IE2	
	15	444	96,68	12098	1,0	KR273-3E80M/4D	1,77	38	108	IE3	
	17	384	83,48	12459	1,2	KR273-2E80M/4C	1,89	36		IE2	
	20	336	72,92	12738	1,3						
	21	315	68,40	12851	1,4						
	25	268	58,15	13094	1,7						
	29	233	50,51	13261	1,9						
	33	204	44,20	13392	2,2						
	40	169	36,55	13541	2,7						
	48	141	30,48	13653	3,2						
	57	118	25,55	13799	3,6						
	63	107	23,08	13908	3,8						
	76	89	19,08	14143	4,0						
		20	334	72,37	5471	0,8	KR203-3E80M/4D	1,77	34	104	IE3
		23	292	63,33	5739	1,0	KR203-2E80M/4C	1,89	33		IE2
28		242	52,37	5719	1,2						
33		202	43,67	5643	1,4						
38		177	38,16	5559	1,6						
46		146	31,55	5408	1,9						
55		122	26,31	5239	2,2						
	61	111	23,79	6507	2,5	KR202-3E80M/4D	1,77	34	104	IE3	
	72	95	20,23	6133	3,0	KR202-2E80M/4C	1,89	33		IE2	
	83	82	17,47	5815	3,3						
	41	163	35,22	4667	0,8	KR103-3E80M/4D	1,77	21	100	IE3	
	44	152	32,90	4646	0,9	KR103-2E80M/4C	1,89	20		IE2	
	52	128	27,81	4574	1,0						
	57	119	25,50	6298	1,0	KR102-3E80M/4D	1,77	21	100	IE3	
	68	99	21,25	5884	1,2	KR102-2E80M/4C	1,89	20		IE2	
	76	90	19,13	5658	1,2						
	84	81	17,30	5452	1,4						
	99	69	14,61	5123	1,6						
	116	59	12,51	4841	1,8						
	131	52	11,05	4626	1,9						
	140	49	10,32	4513	2,1						
	166	41	8,72	4247	2,3						
	199	34	7,29	3981	2,6						
	231	30	6,28	3776	3,0						
	261	26	11,05	3616	3,3	KR102-3E80M/2B	1,59	21	100	IE3	
	279	24	10,32	3530	3,3	KR102-2E80M/2A	1,67	20		IE2	
	73	93	19,88	2961	0,9	KR002-3E80M/4D	1,77	20	96	IE3	
	90	76	16,18	2941	1,0	KR002-2E80M/4C	1,89	19		IE2	
	98	69	14,73	2920	1,1						
	109	62	13,26	2890	1,2						
	131	52	11,09	2822	1,4						
	154	44	9,40	2747	1,6						
	180	38	8,04	2669	1,7						
	194	35	7,46	2630	1,9						

*: IE2 ve IE3 motorlu redüktör fiyatları farklıdır. / Geared motor prices are different for IE2 and IE3 motors. / Preise von Getrieben mit IE2 und IE3 Motoren sind unterschiedlich.

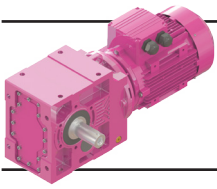

K Serisi Motorlu Güç Devir Sayfaları

K Series Geared Motors Performance Tables

K Serien Getriebemotoren Leistung und Drehzahlübersicht

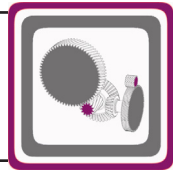

Güç	IE3 Çıkış Devri	IE3 Çıkış Momenti	Çevrim Oranı	IE3 Güv. Rad. Yük Çıkış	IE3 Servis Faktörü	Tipi	Anma Akımı	Ağırlık	Ölçü Sayfası	Motor Verim Snf.*
Power	Output Speeds	Output Torque	Ratio	Per. O. Loads (Output)	Service Factors	Type	Rated Current	Weight	Dim. Page	Motor Eff. Class
Leistung P _g [kW] P _g [HP]	Abtriebswelle Drehzahlen n ₂ [r.p.m]	Abtriebswelle Drehmomente M ₂ [Nm]	Übersetzung i	Zul.Querkräfte (Abtrieb) F _{qam} [N]	Betriebsfaktor f _s	Typ	Nennstrom [A]	Gewicht ~ [kg]	Maße Seite	Motor Effizienz- klasse
0,75 1,0	217	31	13,26	2573	1,9	KR002-3E80M/2B	1,59	18	96	IE3
	260	26	11,09	2471	2,3		KR002-2E80M/2A	1,67		17
	307	22	9,40	2375	2,5					
	358	19	8,04	2284	2,9					
	386	18	7,46	2240	3,1					
1,1 1,5	0,41	22084	3499,30	68850	0,9	KR976-3E90S/4C	2,46	1111	208	IE3
	0,44	20879	3306,00	71762	1,0		KR976-2E90S/4B	2,60		1108
	0,52	17778	2811,23	78410	1,1					
	0,62	14886	2348,01	83727	1,3					
	0,65	14074	2218,31	85054	1,4					
	0,73	12606	1985,89	87308	1,6					
	0,91	10264	1585,92	90719	1,9	KR975-3E90S/4C	2,46	1106	208	IE3
	1,0	9221	1423,89	92139	2,2		KR975-2E90S/4B	2,60		1104
	1,2	7856	1213,78	93883	2,5					
	1,4	6931	1070,02	94989	2,9					
	1,5	6154	949,26	95953	3,3					
	1,7	5491	846,39	96624	3,6					
	2,0	4652	715,34	98886	4,0					
	0,77	12168	1891,08	95780	1,2	KR875-3E90S/4C	2,46	657	196	IE3
	0,87	10771	1671,18	101381	1,4		KR875-2E90S/4B	2,60		655
0,97	9639	1495,27	105337	1,6						
1,1	8479	1313,07	109373	1,8						
1,3	7099	1096,71	113443	2,1						
1,5	6204	957,34	115988	2,4						
1,7	5478	844,51	117936	2,7						
1,9	4878	751,30	119473	3,1						
0,94	9946	1547,01	40762	0,8	KR775-3E90S/4C	2,46	399	184	IE3	
1,1	8706	1353,02	50450	0,9		KR775-2E90S/4B	2,60		397	IE2
1,2	7681	1192,77	56568	1,0						
1,4	6819	1058,16	61043	1,2						
1,5	6083	943,49	64432	1,3						
1,7	5385	833,78	67228	1,5						
1,9	4820	746,01	69510	1,7						
2,2	4241	655,11	71469	1,9						
2,4	4057	396,00	72289	2,0	KR774-3E90L/6C	2,75	348	180	IE3	
2,7	3631	354,32	73579	2,2		KR774-2E90L/6B	2,90		345	IE2
3,0	3194	311,14	74922	2,5						
3,4	2860	278,35	75898	2,8						
3,7	2630	396,00	76498	3,0	KR774-3E90S/4C	2,46	370	180	IE3	
4,1	2354	354,32	77259	3,4		KR774-2E90S/4B	2,60		368	IE2
1,8	5208	809,27	16646	0,8	KR675-3E90S/4C		2,46	257	172	IE3
2,0	4662	724,08	24408	0,9			KR675-2E90S/4B	2,60		255
2,3	4101	635,86	30274	1,0						
2,6	3714	363,81	33437	1,2	KR674-3E90L/6C	2,75		271	168	IE3
2,9	3287	321,51	36489	1,3		KR674-2E90L/6B	2,90	268		IE2
3,4	2797	273,88	39532	1,5						
4,0	2407	363,81	41618	1,8	KR674-3E90S/4C		2,46	270	168	IE3
4,5	2131	321,51	42965	2,0		KR674-2E90S/4B	2,60	268		IE2

*: IE2 ve IE3 motorlu redüktör fiyatları farklıdır. / Geared motor prices are different for IE2 and IE3 motors. / Preise von Getrieben mit IE2 und IE3 Motoren sind unterschiedlich.

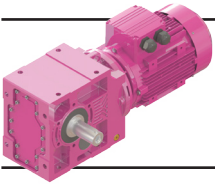

K Serisi Motorlu Güç Devir Sayfaları

K Series Geared Motors Performance Tables

K Serien Getriebemotoren Leistung und Drehzahlübersicht

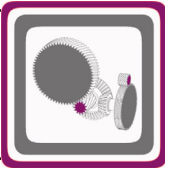

Güç	IE3 Çıkış Devri	IE3 Çıkış Momenti	Çevrim Oranı	IE3 Güv. Rad. Yük Çıkış	IE3 Servis Faktörü	Tipi	Anma Akımı	Ağırlık	Ölçü Sayfası	Motor * Verim Snf.
Power	Output Speeds	Output Torque	Ratio	Per.O. Loads (Output)	Service Factors	Type	Rated Current	Weight	Dim. Page	Motor Eff. Class
Leistung P _g [kW] P _g [HP]	Abtriebswelle Drehzahlen n ₂ [r.p.m]	Abtriebswelle Drehmomente M ₂ [Nm]	Übersetzung i	Zul.Querkräfte (Abtrieb) F _{qam} [N]	Betriebsfaktor f _s	Typ	Nennstrom [A]	Gewicht ~ [kg]	Maße Seite	Motor Effizienz- klasse
1,1 1,5	5,3	1813	273,88	44444	2,4	KR674-3E90S/4C KR674-2E90S/4B	2,46	270	168	IE3
	6,2	1561	235,44	45531	2,8		2,60	268	IE2	
	7,1	1357	204,32	46361	3,2					
	3,1	3085	469,74	18048	0,9	KR574-3E90S/4C KR574-2E90S/4B	2,46	159	156	IE3
	3,7	2611	397,01	23598	1,0		2,60	157	IE2	
	4,4	2166	328,56	27343	1,2					
	5,2	1854	281,00	29553	1,5					
	5,9	1629	246,42	30921	1,7					
	6,1	1571	237,97	31286	1,7					
	6,9	1397	211,51	32230	1,9					
	8,0	1196	180,90	33290	2,3					
	9,1	1051	158,64	34002	2,6					
	10	931	140,24	34561	2,9					
	12	785	117,96	35203	3,4					
	6,1	1594	153,47	16176	1,0	KR473-3E90L/6C KR473-2E90L/6B	2,75	102	140	IE3
	6,9	1412	135,98	17815	1,1		2,90	99	IE2	
	8,5	1151	110,65	19787	1,3					
	9,4	1036	153,47	20546	1,5	KR473-3E90S/4C KR473-2E90S/4B	2,46	101	140	IE3
	11	918	135,98	21262	1,7		2,60	99	IE2	
	13	748	110,65	22168	2,1					
	15	662	97,79	22607	2,3					
	17	592	87,49	22944	2,6					
	19	521	76,83	23291	3,0					
	23	436	64,17	23647	3,6					
	8,5	1148	110,61	6284	0,7	KR373-3E90L/6C KR373-2E90L/6B	2,75	70	128	IE3
	9,7	1011	97,26	9290	0,8		2,90	67	IE2	
	12	814	78,29	12120	1,0					
	13	746	110,61	12896	1,1	KR373-3E90S/4C KR373-2E90S/4B	2,46	70	128	IE3
	15	657	97,26	13804	1,2		2,60	68	IE2	
	19	529	78,29	14925	1,5					
	21	465	68,65	15401	1,8					
	24	411	60,69	15789	2,0					
	28	346	51,05	16226	2,4					
	33	295	43,40	16549	2,8					
	39	253	37,19	16797	3,2					
	14	717	106,33	15179	0,8	KR283-3E90S/4C KR283-2E90S/4B	2,46	47	116	IE3
	16	631	93,50	15808	1,0		2,60	45	IE2	
	19	508	75,26	16599	1,2					
	22	446	66,00	16955	1,3					
	25	395	58,35	17229	1,5					
	30	333	49,08	17537	1,8					
	35	283	41,72	17764	2,1					
	41	243	35,75	17938	2,5					
	45	220	32,35	18032	2,7					
	17	564	83,48	11227	0,8	KR273-3E90S/4C KR273-2E90S/4B	2,46	43	108	IE3
	20	493	72,92	11753	0,9		2,60	41	IE2	
	21	463	68,40	11975	1,0					
	25	393	58,15	12402	1,1					
	29	342	50,51	12703	1,3					
	33	300	44,20	12933	1,5					
	40	248	36,55	13190	1,8					

*: IE2 ve IE3 motorlu redüktör fiyatları farklıdır. / Geared motor prices are different for IE2 and IE3 motors. / Preise von Getrieben mit IE2 und IE3 Motoren sind unterschiedlich.

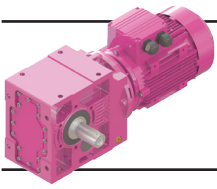

K Serisi Motorlu Güç Devir Sayfaları

K Series Geared Motors Performance Tables

K Serien Getriebemotoren Leistung und Drehzahlübersicht

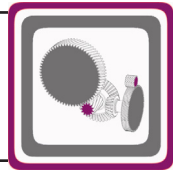

Güç	IE3 Çıkış Devri	IE3 Çıkış Momenti	Çevrim Oranı	IE3 Güv. Rad. Yük Çıkış	IE3 Servis Faktörü	Tipi	Anma Akımı	Ağırlık	Ölçü Sayfası	Motor Verim Snf.*	
Power	Output Speeds	Output Torque	Ratio	Per. O. Loads (Output)	Service Factors	Type	Rated Current	Weight	Dim. Page	Motor Eff. Class	
Leistung P _g [kW] P _g [HP]	Abtriebswelle Drehzahlen n ₂ [r.p.m]	Abtriebswelle Drehmomente M ₂ [Nm]	Übersetzung i	Zul.Querkräfte (Abtrieb) F _{qam} [N]	Betriebsfaktor f _s	Typ	Nennstrom [A]	Gewicht ~ [kg]	Maße Seite	Motor Effizienz- klasse	
1,1 1,5	48	207	30,48	13378	2,2	KR273-3E90S/4C	2,46	43	108	IE3	
	57	174	25,55	13602	2,5		KR273-2E90S/4B	2,60		41	IE2
	63	158	23,08	13741	2,6						
	76	131	19,08	13910	3,0						
	91	109	15,92	14034	3,4						
	109	92	13,34	14147	3,8						
	121	82	12,00	14158	3,1						
	146	68	9,92	13462	3,5						
	175	57	8,28	12819	4,0						
	209	48	6,94	12216	4,0						
	28	355	52,37	4248	0,8	KR203-3E90S/4C	2,46	39	104	IE3	
	33	297	43,67	4663	0,9	KR203-2E90S/4B	2,60	37		IE2	
	38	259	38,16	4718	1,1						
	46	215	31,55	4726	1,3						
	55	179	26,31	4680	1,5						
	61	163	23,79	6646	1,7	KR202-3E90S/4C	2,46	38	104	IE3	
	72	139	20,23	6258	2,0	KR202-2E90S/4B	2,60	36		IE2	
	83	120	17,47	5927	2,2						
	95	105	15,26	5639	2,5						
	101	99	14,32	5508	2,6						
	119	84	12,17	5189	2,9						
	137	73	10,57	4930	3,2						
	64	155	14,61	5374	0,8	KR102-3E90L/6C	2,75	29	100	IE3	
	75	133	12,51	5814	0,9	KR102-2E90L/6B	2,90	26		IE2	
	84	119	17,30	5580	0,9	KR102-3E90S/4C	2,46	25	100	IE3	
	99	101	14,61	5236	1,1	KR102-2E90S/4B	2,60	23		IE2	
	116	86	12,51	4942	1,2						
	131	76	11,05	4719	1,3						
	140	71	10,32	4601	1,4						
	166	60	8,72	4324	1,6						
	199	50	7,29	4047	1,8						
	231	43	6,28	3834	2,1						
		261	38	11,05	3668	2,2	KR102-3E80M/2C	2,26	21	100	IE3
		279	36	10,32	3579	2,2	KR102-2E80M/2B	2,36	19		IE2
330		30	8,72	3369	2,6						
395		25	7,29	3159	3,0						
458		22	6,28	2997	3,2						
	109	91	13,26	2421	0,8	KR002-3E90S/4C	2,46	25	96	IE3	
	131	76	11,09	2439	1,0	KR002-2E90S/4B	2,60	23		IE2	
	154	65	9,40	2428	1,1						
	180	56	8,04	2400	1,2						
	194	52	7,46	2382	1,3						
	217	46	13,26	2353	1,3	KR002-3E80M/2C	2,26	20	96	IE3	
	260	38	11,09	2290	1,6	KR002-2E80M/2B	2,36	18		IE2	
	307	33	9,40	2223	1,7						
	358	28	8,04	2155	2,0						
	386	26	7,46	2121	2,1						
1,5 2,0	0,52	24242	2811,23	63087	0,8	KR976-3E90L/4D	3,30	1113	208	IE3	
	0,62	20299	2348,01	73153	1,0	KR976-2E90L/4C	3,40	1110		IE2	
	0,65	19192	2218,31	75519	1,0						

*: IE2 ve IE3 motorlu redüktör fiyatları farklıdır. / Geared motor prices are different for IE2 and IE3 motors. / Preise von Getrieben mit IE2 und IE3 Motoren sind unterschiedlich.

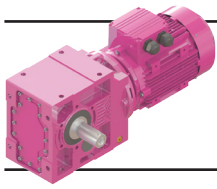

K Serisi Motorlu Güç Devir Sayfaları

K Series Geared Motors Performance Tables

K Serien Getriebemotoren Leistung und Drehzahlübersicht

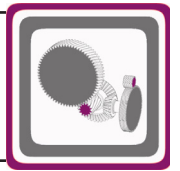

Güç	IE3 Çıkış Devri	IE3 Çıkış Momenti	Çevrim Oranı	IE3 Güv. Rad. Yük Çıkış	IE3 Servis Faktörü	Tipi	Anma Akımı	Ağırlık	Ölçü Sayfası	Motor Verim Snf.*
Power	Output Speeds	Output Torque	Ratio	Per.O. Loads (Output)	Service Factors	Type	Rated Current	Weight	Dim. Page	Motor Eff. Class
Leistung P _g [kW] P _g [HP]	Abtriebswelle Drehzahlen n ₂ [r.p.m]	Abtriebswelle Drehmomente M ₂ [Nm]	Übersetzung i	Zul.Querkräfte (Abtrieb) F _{qam} [N]	Betriebsfaktor f _s	Typ	Nennstrom [A]	Gewicht ~ [kg]	Maße Seite	Motor Effizienz-klasse
1,5 2,0	0,73	17190	1985,89	79582	1,2	KR976-3E90L/4D KR976-2E90L/4C	3,30 3,40	1113 1110	208	IE3 IE2
	0,91 1,0 1,2 1,4 1,5 1,7 2,0	13996 12575 10712 9452 8391 7487 6344	1585,92 1423,89 1213,78 1070,02 949,26 846,39 715,34	85179 87431 90163 91875 93313 94358 95683	1,4 1,6 1,9 2,1 2,4 2,7 3,2	KR975-3E90L/4D KR975-2E90L/4C	3,30 3,40	1108 1105	208	IE3 IE2
2,2 2,5 2,8	0,97 1,1 1,3 1,5 1,7 1,9	13144 11563 9680 8460 7470 6652	1495,27 1313,07 1096,71 957,34 844,51 751,30	91475 98281 100689 104678 107455 109747	1,1 1,3 1,5 1,8 2,0 2,3	KR875-3E90L/4D KR875-2E90L/4C	3,30 3,40	659 658	196	IE3 IE2
	2,2 2,5 2,8	6023 5282 4681	438,70 383,99 339,70	111593 113316 114765	2,5 2,8 3,2	KR874-3E100L/6B KR874-2E100L/6A	3,50 3,72	895 892	192	IE3 IE2
	1,4 1,5 1,7 1,9 2,2	9298 8295 7344 6573 5783	1058,16 943,49 833,78 746,01 655,11	46159 52976 58389 62215 65720	0,9 1,0 1,1 1,2 1,4	KR775-3E90L/4D KR775-2E90L/4C	3,30 3,40	428 427	184	IE3 IE2
	2,4 2,7 3,1 3,4	5445 4873 4287 3839	396,00 354,32 311,14 278,35	66988 69216 71333 72930	1,5 1,6 1,9 2,1	KR774-3E100L/6B KR774-2E100L/6A	3,50 3,72	414 411	180	IE3 IE2
	3,7 4,1 4,7 5,2 6,0	3586 3210 2823 2529 2184	396,00 354,32 311,14 278,35 240,71	73641 74809 75948 76780 77712	2,2 2,5 2,8 3,2 3,7	KR774-3E90L/4D KR774-2E90L/4C	3,30 3,40	410 409	180	IE3 IE2
	2,6 3,0 3,5	4984 4412 3754	363,81 321,51 273,88	20305 27178 33125	0,9 1,0 1,1	KR674-3E100L/6B KR674-2E100L/6A	3,50 3,72	308 305	168	IE3 IE2
4,0 4,5 5,3 6,2 7,1 8,1 9,2	3283 2906 2472 2129 1850 1619 1425	363,81 321,51 273,88 235,44 204,32 178,62 157,02	36521 38894 41257 42977 44279 45286 46088	1,3 1,5 1,7 2,0 2,3 2,7 3,0	KR674-3E90L/4D KR674-2E90L/4C	3,30 3,40	303 302	168	IE3 IE2	
4,4 5,2 5,9 6,1 6,9	2954 2528 2221 2142 1906	328,56 281,00 246,42 237,97 211,51	19787 24321 26922 27526 29208	0,9 1,1 1,2 1,3 1,4	KR574-3E90L/4D KR574-2E90L/4C	3,30 3,40	163 162	156	IE3 IE2	

*: IE2 ve IE3 motorlu redüktör fiyatları farklıdır. / Geared motor prices are different for IE2 and IE3 motors. / Preise von Getrieben mit IE2 und IE3 Motoren sind unterschiedlich.

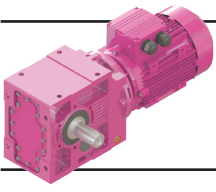

K Serisi Motorlu Güç Devir Sayfaları

K Series Geared Motors Performance Tables

K Serien Getriebemotoren Leistung und Drehzahlübersicht

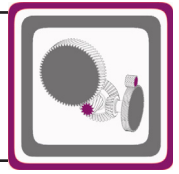

Güç	IE3 Çıkış Devri	IE3 Çıkış Momenti	Çevrim Oranı	IE3 Güv. Rad. Yük Çıkış	IE3 Servis Faktörü	Tipi	Anma Akımı	Ağırlık	Ölçü Sayfası	Motor Verim Snf.*
Power	Output Speeds	Output Torque	Ratio	Per. O. Loads (Output)	Service Factors	Type	Rated Current	Weight	Dim. Page	Motor Eff. Class
Leistung P _g [kW] P _g [HP]	Abtriebswelle Drehzahlen n ₂ [r.p.m]	Abtriebswelle Drehmomente M ₂ [Nm]	Übersetzung i	Zul.Querkräfte (Abtrieb) F _{qam} [N]	Betriebsfaktor f _s	Typ	Nennstrom [A]	Gewicht ~ [kg]	Maße Seite	Motor Effizienz- klasse
1,5 2,0	7,6	1751	125,51	30219	1,5	KR573-3E100L/6B	3,50	155	152	IE3
	8,7	1534	109,86	31473	1,8	KR573-2E100L/6A	3,72	152		IE2
	9,8	1359	97,19	32492	2,0					
	12	1150	82,14	33561	2,3					
	14	943	67,37	34510	2,9					
	16	834	59,49	34996	3,2					
	8,6	1545	110,65	16645	1,0	KR473-3E100L/6B KR473-2E100L/6A	3,50 3,72	109 106	140	IE3 IE2
	9,4	1414	153,47	17802	1,1	KR473-3E90L/4D	3,30	103	140	IE3
	11	1252	135,98	19067	1,2	KR473-2E90L/4C	3,40	102		IE2
	13	1021	110,65	20637	1,5					
15	903	97,79	21344	1,7						
17	808	87,49	21845	1,9						
19	711	76,83	22362	2,2						
23	595	64,17	22934	2,6						
24	562	60,63	23086	2,8						
13	1019	110,61	9109	0,8	KR373-3E90L/4D	3,30	72	128	IE3	
15	897	97,26	11080	0,9	KR373-2E90L/4C	3,40	71		IE2	
19	722	78,29	13151	1,1						
21	634	68,65	13994	1,3						
24	561	60,69	14661	1,5						
28	473	51,05	15340	1,7						
33	402	43,40	15850	2,0						
39	345	37,19	16233	2,4						
43	313	33,65	16440	2,6						
19	694	75,26	15355	0,9	KR283-3E90L/4D	3,30	48	116	IE3	
22	609	66,00	15969	1,0	KR283-2E90L/4C	3,40	47		IE2	
25	539	58,35	16413	1,1						
30	454	49,08	16912	1,3						
35	387	41,72	17272	1,6						
41	332	35,75	17542	1,8						
45	300	32,35	17687	2,0						
25	537	58,15	11437	0,8	KR273-3E90L/4D	3,30	45	108	IE3	
29	467	50,51	11945	1,0	KR273-2E90L/4C	3,40	44		IE2	
33	409	44,20	12305	1,1						
40	339	36,55	12722	1,3						
48	283	30,48	13019	1,6						
57	237	25,55	13332	1,8						
63	215	23,08	13515	1,9						
76	178	19,08	13742	2,2						
91	149	15,92	13907	2,5						
109	125	13,34	14050	2,8						
121	112	12,00	13884	2,2						
146	93	9,92	13235	2,6						
175	77	8,28	12630	3,0						
209	65	6,94	12057	3,4						
38	354	38,16	3679	0,8	KR203-3E90L/4D	3,30	41	104	IE3	
46	293	31,55	3892	1,0	KR203-2E90L/4C	3,40	40		IE2	
55	245	26,31	4001	1,1						
61	223	23,79	6772	1,3	KR202-3E90L/4D	3,30	40	104	IE3	
72	190	20,23	6376	1,5	KR202-2E90L/4C	3,40	39		IE2	
83	164	17,47	6036	1,6						

*: IE2 ve IE3 motorlu redüktör fiyatları farklıdır. / Geared motor prices are different for IE2 and IE3 motors. / Preise von Getrieben mit IE2 und IE3 Motoren sind unterschiedlich.

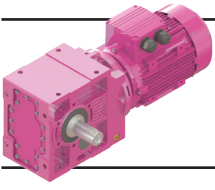

K Serisi Motorlu Güç Devir Sayfaları

K Series Geared Motors Performance Tables

K Serien Getriebemotoren Leistung und Drehzahlübersicht

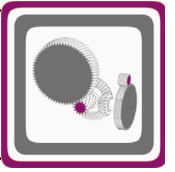

Güç	IE3 Çıkış Devri	IE3 Çıkış Momenti	Çevrim Oranı	IE3 Güv. Rad. Yük Çıkış Per.O. Loads (Output)	IE3 Servis Faktörü	Tipi	Anma Akımı	Ağırlık	Ölçü Sayfası	Motor Verim Snf.*
Power	Output Speeds	Output Torque	Ratio	Per.O. Loads (Output)	Service Factors	Type	Rated Current	Weight	Dim. Page	Motor Eff. Class
Leistung P _g [kW] P _g [HP]	Abtriebswelle Drehzahlen n ₂ [r.p.m]	Abtriebswelle Drehmomente M ₂ [Nm]	Übersetzung i	Zul.Querkräfte (Abtrieb) F _{qam} [N]	Betriebsfaktor f _s	Typ	Nennstrom [A]	Gewicht ~ [kg]	Maße Seite	Motor Effizienz-klasse
1,5 2,0	95	144	15,26	5739	1,8	KR202-3E90L/4D	3,30	40	104	IE3
	101	135	14,32	5604	1,9	KR202-2E90L/4C	3,40	39		IE2
	119	115	12,17	5276	2,1					
	137	100	10,57	5007	2,4					
	157	87	9,25	4767	2,6					
	190	72	7,65	4446	3,0					
	227	60	6,38	4162	3,4					
	99	137	14,61	5343	0,8	KR102-3E90L/4D	3,30	27	100	IE3
	116	118	12,51	5040	0,9	KR102-2E90L/4C	3,40	26		IE2
	131	104	11,05	4810	1,0					
	140	97	10,32	4688	1,0					
	166	82	8,72	4401	1,2					
	199	69	7,29	4115	1,3					
	231	59	6,28	3895	1,5					
	262	52	11,05	3714	1,6	KR102-3E90S/2B	2,97	25	100	IE3
	281	48	10,32	3622	1,6	KR102-2E90S/2A	3,19	23		IE2
	332	41	8,72	3405	2,0					
	398	34	7,29	3189	2,2					
	462	30	6,28	3023	2,4					
	154	88	9,40	2037	0,8	KR002-3E90L/4D	3,30	26	96	IE3
	180	76	8,04	2072	0,9	KR002-2E90L/4C	3,40	25		IE2
	194	70	7,46	2080	0,9					
	309	44	9,40	2042	1,2	KR002-3E90S/2B	2,97	24	96	IE3
	361	38	8,04	2002	1,5	KR002-2E90S/2A	3,19	22		IE2
389	35	7,46	1980	1,6						
2,2 3,0	0,73	25212	1985,89	60017	0,8	KR976-3E100L/4C	4,65	1120	208	IE3
						KR976-2E100L/4B	4,85	1118		IE2
	0,91	20527	1585,92	72502	1,0	KR975-3E100L/4C	4,65	1115	208	IE3
	1,0	18443	1423,89	77077	1,1	KR975-2E100L/4B	4,85	1113		IE2
	1,2	15711	1213,78	82281	1,3					
	1,4	13862	1070,02	85425	1,4					
	1,5	12307	949,26	87941	1,6					
	1,7	10981	846,39	89820	1,8					
	2,0	9304	715,34	92129	2,1					
	2,2	8567	659,09	93014	2,3					
	2,5	7641	586,70	94226	2,6					
	2,8	6761	518,12	95176	3,0					
	3,2	6020	460,51	95989	3,3					
	3,6	5321	398,92	96705	3,8	KR974-3E100L/4C	4,65	1100	204	IE3
						KR974-2E100L/4B	4,85	1098		IE2
	1,5	12408	957,34	90454	1,2	KR875-3E100L/4C	4,65	688	196	IE3
	1,7	10956	844,51	96153	1,4	KR875-2E100L/4B	4,85	686		IE2
	1,9	9756	751,30	100520	1,5					
	2,2	8746	673,01	103816	1,7					
	2,5	7667	383,99	106918	2,0	KR874-3E112M/6B	4,95	678	192	IE3
	2,8	6794	339,70	109386	2,2	KR874-2E112M/6A	5,32	675		IE2

*: IE2 ve IE3 motorlu redüktör fiyatları farklıdır. / Geared motor prices are different for IE2 and IE3 motors. / Preise von Getrieben mit IE2 und IE3 Motoren sind unterschiedlich.

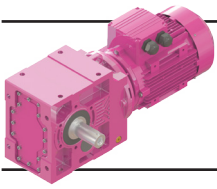

K Serisi Motorlu Güç Devir Sayfaları

K Series Geared Motors Performance Tables

K Serien Getriebemotoren Leistung und Drehzahlübersicht

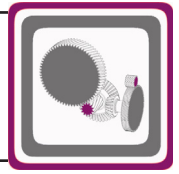

Güç	IE3 Çıkış Devri	IE3 Çıkış Momenti	Çevrim Oranı	IE3 Güv. Rad. Yük Çıkış	IE3 Servis Faktörü	Tipi	Anma Akımı	Ağırlık	Ölçü Sayfası	Motor Verim Snf.*
Power	Output Speeds	Output Torque	Ratio	Per.O. Loads (Output)	Service Factors	Type	Rated Current	Weight	Dim. Page	Motor Eff. Class
Leistung P _g [kW] P _g [HP]	Abtriebswelle Drehzahlen n ₂ [r.p.m]	Abtriebswelle Drehmomente M ₂ [Nm]	Übersetzung i	Zul.Querkräfte (Abtrieb) F _{qam} [N]	Betriebsfaktor f _s	Typ	Nennstrom [A]	Gewicht ~ [kg]	Maße Seite	Motor Effizienz-klasse
2,2 3,0	3,3	5818	438,70	111999	2,6	KR874-3E100L/4C	4,65	697	192	IE3
	3,8	5103	383,99	113778	2,9	KR874-2E100L/4B	4,85	695		IE2
	4,3	4522	339,70	115157	3,3					
	5,1	3831	287,10	116725	3,9					
	6,2	3145	235,47	122868	4,0					
	1,9	9640	746,01	43697	0,8	KR775-3E100L/4C	4,65	410	184	IE3
	2,2	8482	655,11	51811	0,9	KR775-2E100L/4B	4,85	408		IE2
	2,4	7903	396,00	55312	1,0	KR774-3E112M/6B	4,95	387	180	IE3
	2,7	7073	354,32	59782	1,1	KR774-2E112M/6A	5,32	3843		IE2
	3,1	6222	311,14	63818	1,3					
	3,5	5573	278,35	66590	1,4					
	3,7	5260	396,00	67765	1,5	KR774-3E100L/4C	4,65	383	180	IE3
	4,1	4707	354,32	69865	1,7	KR774-2E100L/4B	4,85	381		IE2
	4,7	4141	311,14	71861	1,9					
	5,2	3709	278,35	73290	2,2					
	6,0	3203	240,71	74861	2,5					
	7,0	2778	208,42	76105	2,9					
	8,0	2433	182,29	77065	3,3					
	4,0	4815	363,81	22700	0,9	KR674-3E100L/4C	4,65	280	168	IE3
	4,5	4262	321,51	28741	1,0	KR674-2E100L/4B	4,85	278		IE2
	5,3	3626	273,88	34100	1,2					
	6,2	3122	235,44	37497	1,4					
	7,1	2713	204,32	39957	1,6					
	7,5	2612	128,24	40492	1,6	KR673-3E112M/6B	4,95	228	164	IE3
	9,6	2057	100,90	43338	2,1	KR673-2E112M/6A	5,32	225		IE2
	11	1841	90,21	44333	2,3					
	11	1744	128,24	44776	2,5	KR673-3E100L/4C	4,65	323	164	IE3
	14	1373	100,90	46314	3,1	KR673-2E100L/4B	4,85	321		IE2
	16	1229	90,21	46873	3,5					
	5,9	3257	246,42	15565	0,8	KR574-3E100L/4C	4,65	171	156	IE3
	6,1	3142	237,97	17405	0,9	KR574-2E100L/4B	4,85	169		IE2
	6,9	2795	211,51	21659	1,0					
	8,0	2392	180,90	25521	1,1					
	8,8	2230	109,86	26853	1,2	KR573-3E112M/6B	4,95	159	152	IE3
	9,9	1975	97,19	28736	1,4	KR573-2E112M/6A	5,32	156		IE2
	12	1698	125,51	30509	1,6	KR573-3E100L/4C	4,65	156	152	IE3
	13	1488	109,86	31752	1,8	KR573-2E100L/4B	4,85	154		IE2
	15	1318	97,19	32683	2,0					
	18	1116	82,14	33708	2,4					
	22	916	67,37	34643	2,9					
	24	809	59,49	35108	3,3					
	13	1498	110,65	17069	1,0	KR473-3E100L/4C	4,65	111	140	IE3
	15	1326	97,79	18493	1,2	KR473-2E100L/4B	4,85	109		IE2
	17	1186	87,49	19515	1,3					
	19	1043	76,83	20477	1,5					
	23	872	64,17	21504	1,8					

*: IE2 ve IE3 motorlu redüktör fiyatları farklıdır. / Geared motor prices are different for IE2 and IE3 motors. / Preise von Getrieben mit IE2 und IE3 Motoren sind unterschiedlich.

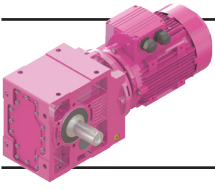

K Serisi Motorlu Güç Devir Sayfaları

K Series Geared Motors Performance Tables

K Serien Getriebemotoren Leistung und Drehzahlübersicht

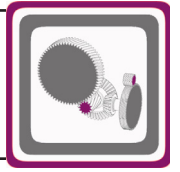

Güç	IE3 Çıkış Devri	IE3 Çıkış Momenti	Çevrim Oranı	IE3 Güv. Rad. Yük Çıkış	IE3 Servis Faktörü	Tipi	Anma Akımı	Ağırlık	Ölçü Sayfası	Motor Verim Snf.*
Power	Output Speeds	Output Torque	Ratio	Per.O. Loads (Output)	Service Factors	Type	Rated Current	Weight	Dim. Page	Motor Eff. Class
Leistung P _g [kW] P _g [HP]	Abtriebswelle Drehzahlen n ₂ [r.p.m]	Abtriebswelle Drehmomente M ₂ [Nm]	Übersetzung i	Zul.Querkräfte (Abtrieb) F _{qam} [N]	Betriebsfaktor f _s	Typ	Nennstrom [A]	Gewicht ~ [kg]	Maße Seite	Motor Effizienz-klasse
2,2 3,0	24	825	60,63	21771	1,9	KR473-3E100L/4C	4,65	111	140	IE3
	24	804	59,19	21883	1,9	KR473-2E100L/4B	4,85	109		IE2
	28	697	51,22	22444	2,2					
	32	608	44,64	22879	2,5					
	37	533	39,11	23212	2,9					
	48	413	30,11	23753	3,8					
	19	1060	78,29	8376	0,8	KR373-3E100L/4C	4,65	82	128	IE3
	21	931	68,65	10572	0,9	KR373-2E100L/4B	4,85	80		IE2
	24	824	60,69	12006	1,0					
	28	694	51,05	13419	1,2					
	33	591	43,40	14412	1,4					
	39	507	37,19	15090	1,6					
	43	459	33,65	15456	1,8					
	50	393	28,85	15923	2,1					
	59	337	24,72	16292	2,4					
	66	301	21,90	16519	2,7					
	78	256	18,62	16777	3,2					
	30	667	49,08	15537	0,9	KR283-3E100L/4C	4,65	55	116	IE3
	35	567	41,72	16235	1,1	KR283-2E100L/4B	4,85	53		IE2
	41	487	35,75	16727	1,2					
	45	441	32,35	16985	1,4					
	52	378	27,74	17317	1,6					
	61	324	23,76	17578	1,9					
	68	294	21,42	17717	2,0					
	80	250	18,21	17908	2,4					
	93	215	15,60	18054	2,8					
	103	194	14,12	17886	3,1					
		33	600	44,20	10904	0,7	KR273-3E100L/4C	4,65	53	108
40		497	36,55	11733	0,9	KR273-2E100L/4B	4,85	51		IE2
48		415	30,48	12275	1,1					
57		348	25,55	12785	1,2					
63		316	23,08	13060	1,3					
76		262	19,08	13409	1,5					
91		218	15,92	13658	1,7					
109		183	13,34	13861	1,9					
121		164	12,00	13403	1,5					
146		136	9,92	12838	1,8					
175		114	8,28	12299	2,0					
209	95	6,94	11780	2,3						
	217	92	13,34	13947	3,3	KR273-3E90L/2C	4,25	46	108	IE3
	242	82	12,00	13403	2,7	KR273-2E90L/2B	4,48	44		IE2
	292	68	9,92	12838	3,1					
	350	57	8,28	12299	3,5					
	418	48	6,94	11780	4,0					
	95	211	15,26	5873	1,2	KR202-3E100L/4C	4,65	47	104	IE3
	101	198	14,32	5735	1,3	KR202-2E100L/4B	4,85	45		IE2
	119	168	12,17	5398	1,5					
	137	146	10,57	5121	1,6					
	157	128	9,25	4872	1,8					
	190	106	7,65	4539	2,0					
	227	89	6,38	4243	2,3					
	314	64	9,25	3768	2,9	KR202-3E90L/2C	4,25	40	104	IE3
	379	53	7,65	3516	3,3	KR202-2E90L/2B	4,48	38		IE2

*: IE2 ve IE3 motorlu redüktör fiyatları farklıdır. / Geared motor prices are different for IE2 and IE3 motors. / Preise von Getrieben mit IE2 und IE3 Motoren sind unterschiedlich.

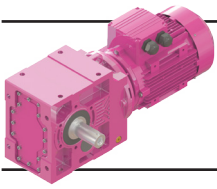

K Serisi Motorlu Güç Devir Sayfaları

K Series Geared Motors Performance Tables

K Serien Getriebemotoren Leistung und Drehzahlübersicht

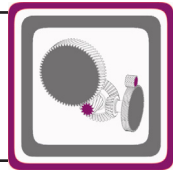

Güç	IE3 Çıkış Devri	IE3 Çıkış Momenti	Çevrim Oranı	IE3 Güv. Rad. Yük Çıkış	IE3 Servis Faktörü	Tipi	Anma Akımı	Ağırlık	Ölçü Sayfası	Motor Verim Snf.*
Power	Output Speeds	Output Torque	Ratio	Per.O. Loads (Output)	Service Factors	Type	Rated Current	Weight	Dim. Page	Motor Eff. Class
Leistung P _g [kW] P _g [HP]	Abtriebswelle Drehzahlen n ₂ [r.p.m]	Abtriebswelle Drehmomente M ₂ [Nm]	Übersetzung i	Zul.Querkräfte (Abtrieb) F _{qam} [N]	Betriebsfaktor f _s	Typ	Nennstrom [A]	Gewicht ~ [kg]	Maße Seite	Motor Effizienz- klasse
2,2 3,0	455	44	6,38	3292	3,7	KR202-3E90L/2C KR202-2E90L/2B	4,25 4,48	40 38	104	IE3 IE2
3,0 4,0	1,0 1,2 1,4 1,5 1,7 2,0 2,2 2,5 2,8 3,2	25149 21425 18903 16783 14974 12687 11683 10420 9220 8210	1423,89 1213,78 1070,02 949,26 846,39 715,34 659,09 586,70 518,12 460,51	60373 70469 76208 80397 83604 87284 88810 90594 92175 93438	0,8 0,9 1,1 1,2 1,3 1,6 1,7 1,9 2,2 2,4	KR975-3E100L/4D KR975-2E100L/4C	6,26 6,42	1095 1090	208	IE3 IE2
	3,6 4,1 4,8	7256 6521 5559	398,92 358,16 305,31	94556 95369 96535	2,8 3,1 3,6	KR974-3E100L/4D KR974-2E100L/4C	6,26 6,42	1080 1075	204	IE3 IE2
	2,2 2,5	11926 10355	673,01 584,66	92419 98329	1,3 1,4	KR875-3E100L/4D KR875-2E100L/4C	6,26 6,42	670 667	196	IE3 IE2
	2,9	9217	339,70	102283	1,6	KR874-3E132S/6B KR874-2E132S/6A	6,55 6,85	699 694	192	IE3 IE2
	3,3 3,8 4,3 5,1 6,2 7,0 7,8	7934 6958 6166 5223 4289 3794 3378	438,70 383,99 339,70 287,10 235,47 207,95 184,83	106177 108971 111100 113484 115693 116805 120594	1,9 2,2 2,4 2,9 3,5 4,0 4,0	KR874-3E100L/4D KR874-2E100L/4C	6,26 6,42	651 648	192	IE3 IE2
	3,1 3,5	8441 7560	311,14 278,35	52078 57218	0,9 1,1	KR774-3E132S/6B KR774-2E132S/6A	6,55 6,85	414 409	180	IE3 IE2
	3,7 4,1 4,7 5,2 6,0 7,0 8,0	7172 6419 5647 5057 4368 3789 3318	396,00 354,32 311,14 278,35 240,71 208,42 182,29	59150 62825 66285 68627 71078 73032 74513	1,1 1,2 1,4 1,6 1,8 2,1 2,4	KR774-3E100L/4D KR774-2E100L/4C	6,26 6,42	386 383	180	IE3 IE2
	8,7 9,8 11 13	3092 2745 2459 2124	111,63 99,00 88,57 76,59	75258 76225 77020 77906	2,6 2,9 3,3 3,8	KR773-3E132S/6B KR773-2E132S/6A	6,55 6,85	396 391	176	IE3 IE2
	5,3 6,2 7,1	4945 4257 3700	273,88 235,44 204,32	20850 28787 33544	0,9 1,0 1,2	KR674-3E100L/4D KR674-2E100L/4C	6,26 6,42	281 278	168	IE3 IE2
	7,6 9,6 11	3541 2788 2495	128,24 100,90 90,21	34722 39578 41195	1,2 1,5 1,7	KR673-3E132S/6B KR673-2E132S/6A	6,55 6,85	246 241	164	IE3 IE2

*: IE2 ve IE3 motorlu redüktör fiyatları farklıdır. / Geared motor prices are different for IE2 and IE3 motors. / Preise von Getrieben mit IE2 und IE3 Motoren sind unterschiedlich.

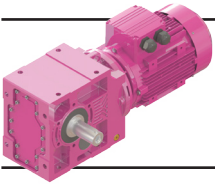

K Serisi Motorlu Güç Devir Sayfaları

K Series Geared Motors Performance Tables

K Serien Getriebemotoren Leistung und Drehzahlübersicht

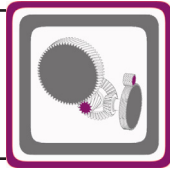

Güç	IE3 Çıkış Devri	IE3 Çıkış Momenti	Çevrim Oranı	IE3 Güv. Rad. Yük Çıkış	IE3 Servis Faktörü	Tipi	Anma Akımı	Ağırlık	Ölçü Sayfası	Motor Verim Snf.*
Power	Output Speeds	Output Torque	Ratio	Per.O. Loads (Output)	Service Factors	Type	Rated Current	Weight	Dim. Page	Motor Eff. Class
Leistung P _g [kW] P _g [HP]	Abtriebswelle Drehzahlen n ₂ [r.p.m]	Abtriebswelle Drehmomente M ₂ [Nm]	Übersetzung i	Zul.Querkräfte (Abtrieb) F _{qam} [N]	Betriebsfaktor f _s	Typ	Nennstrom [A]	Gewicht ~ [kg]	Maße Seite	Motor Effizienz-klasse
3,0 4,0	11	2379	128,24	41835	1,8	KR673-3E100L/4D	6,26	223	164	IE3
	14	1874	100,90	44201	2,3	KR673-2E100L/4C	6,42	220		IE2
	16	1677	90,21	45064	2,6					
	18	1496	80,38	45821	2,9					
8,0		3262	180,90	15479	0,8	KR574-3E100L/4D KR574-2E100L/4C	6,26 6,42	172 169	156	IE3 IE2
	10	2677	97,19	22912	1,0	KR573-3E132S/6B KR573-2E132S/6A	6,55 6,85	192 187	152	IE3 IE2
12 13 15 18 22 24 27	12	2317	125,51	26087	1,2	KR573-3E100L/4D	6,26	157	152	IE3
	13	2031	109,86	28341	1,3	KR573-2E100L/4C	6,42	154		IE2
	15	1799	97,19	29906	1,5					
	18	1522	82,14	31557	1,8					
	22	1249	67,37	33041	2,2					
	24	1105	59,49	33763	2,4					
	27	983	52,88	34338	2,7					
	30 35	895 757	97,19 82,14	34748 35668	3,0 3,4	KR573-3E100L/2C KR573-2E100L/2B	5,58 5,80	155 152	152	IE3 IE2
15 17 19 23 24 24 28 32 37 48 58	15	1809	97,79	13841	0,9	KR473-3E100L/4D	6,26	113	140	IE3
	17	1618	87,49	15934	1,0	KR473-2E100L/4C	6,42	110		IE2
	19	1423	76,83	17682	1,1					
	23	1190	64,17	19514	1,3					
	24	1125	60,63	19936	1,4					
	24	1097	59,19	20157	1,4					
	28	951	51,22	21047	1,6					
	32	830	44,64	21743	1,9					
	37	728	39,11	22295	2,1					
	48	563	30,11	23068	2,8					
	58	471	25,15	23327	3,3					
	28 33 39 43 50 59 66 78 91	28	947	51,05	10331	0,9	KR373-3E100L/4D	6,26	83	128
33		806	43,40	12220	1,0	KR373-2E100L/4C	6,42	80		IE2
39		691	37,19	13443	1,2					
43		626	33,65	14092	1,3					
50		537	28,85	14875	1,5					
59		460	24,72	15446	1,8					
66		411	21,90	15803	2,0					
78		350	18,62	16219	2,3					
91		300	15,96	16528	2,7					
100		272	14,44	16687	3,0	KR373-3E100L/4D KR373-2E100L/4C	6,26 6,42	83 80	128	IE3 IE2
41 45 52 61 68 80 93 103 120 140	41	664	35,75	15556	0,9	KR283-3E100L/4D	6,26	57	116	IE3
	45	602	32,35	16025	1,0	KR283-2E100L/4C	6,42	55		IE2
	52	516	27,74	16557	1,2					
	61	442	23,76	16979	1,4					
	68	401	21,42	17199	1,5					
	80	341	18,21	17496	1,8					
	93	293	15,60	17721	2,0					
	103	265	14,12	17452	2,3					
	120	227	12,10	16824	2,5					
	140	195	10,37	16197	2,8					

*: IE2 ve IE3 motorlu redüktör fiyatları farklıdır. / Geared motor prices are different for IE2 and IE3 motors. / Preise von Getrieben mit IE2 und IE3 Motoren sind unterschiedlich.

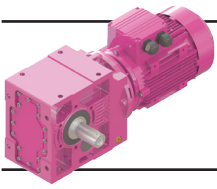

K Serisi Motorlu Güç Devir Sayfaları

K Series Geared Motors Performance Tables

K Serien Getriebemotoren Leistung und Drehzahlübersicht

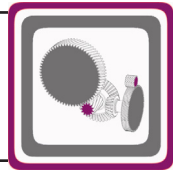

Güç	IE3 Çıkış Devri	IE3 Çıkış Momenti	Çevrim Oranı	IE3 Güv. Rad. Yük Çıkış	IE3 Servis Faktörü	Tipi	Anma Akımı	Ağırlık	Ölçü Sayfası	Motor Verim Snf.*
Power	Output Speeds	Output Torque	Ratio	Per.O. Loads (Output)	Service Factors	Type	Rated Current	Weight	Dim. Page	Motor Eff. Class
Leistung P _g [kW] P _g [HP]	Abtriebswelle Drehzahlen n ₂ [r.p.m]	Abtriebswelle Drehmomente M ₂ [Nm]	Übersetzung i	Zul.Querkräfte (Abtrieb) F _{qam} [N]	Betriebsfaktor f _s	Typ	Nennstrom [A]	Gewicht ~ [kg]	Maße Seite	Motor Effizienz- klasse
3,0 4,0	143	191	10,16	15847	1,9	KR283-3E100L/4D	6,26	57	116	IE3
	168	162	8,63	15241	2,2	KR283-2E100L/4C	6,42	55		IE2
	196	139	7,40	14670	2,5					
	217	126	6,70	14305	2,7					
	253	108	5,74	13752	3,1					
	48	566	30,48	11203	0,8	KR273-3E100L/4D	6,26	55	108	IE3
	57	475	25,55	12026	0,9	KR273-2E100L/4C	6,42	52		IE2
	63	431	23,08	12426	1,0					
	76	357	19,08	12947	1,1					
	91	298	15,92	13328	1,2					
	109	250	13,34	13420	1,4					
	121	224	12,00	12855	1,1					
	146	186	9,92	12384	1,3					
	175	155	8,28	11920	1,5					
	209	130	6,94	11462	1,7					
	218	125	13,34	13420	2,4	KR273-3E100L/2C	5,58	51	108	IE3
	243	112	12,00	12855	2,0	KR273-2E100L/2B	5,80	48		IE2
	294	92	9,92	12384	2,3					
	352	77	8,28	11920	2,6					
	420	65	6,94	11462	2,9					
95	288	15,26	5955	0,9	KR202-3E100L/4D	6,26	49	104	IE3	
101	270	14,32	5822	0,9	KR202-2E100L/4C	6,42	46		IE2	
119	230	12,17	5491	1,1						
137	200	10,57	5215	1,2						
157	175	9,25	4964	1,3						
190	145	7,65	4625	1,5						
227	121	6,38	4322	1,7						
315	87	9,25	3825	2,1	KR202-3E100L/2C	5,58	46	104	IE3	
381	72	7,65	3565	2,4	KR202-2E100L/2B	5,80	43		IE2	
457	60	6,38	3334	2,7						
4,0 5,5	1,4	25031	1070,02	60768	0,8	KR975-3E112M/4D	8,05	1108	208	IE3
	1,5	22224	949,26	68501	0,9	KR975-2E112M/4C	8,20	1105		IE2
	1,7	19829	846,39	74160	1,0					
	2,0	16801	715,34	80302	1,2					
	2,2	15470	659,09	82814	1,3					
	2,5	13798	586,70	85532	1,4					
	2,8	12209	518,12	88072	1,6					
	3,2	10871	460,51	89940	1,8					
	3,7	9608	398,92	91640	2,1	KR974-3E112M/4D	8,05	1090	204	IE3
	4,1	8635	358,16	92868	2,3	KR974-2E112M/4C	8,20	1087		IE2
	4,8	7361	305,31	94373	2,7					
	5,4	6497	269,15	95493	3,1					
	6,1	5771	238,77	96305	3,5					
	8,0	4403	181,51	100058	4,0					
	2,8	12068	514,05	92017	1,2	KR875-3E112M/4D	8,05	677	196	IE3
	3,1	10899	463,83	96505	1,4	KR875-2E112M/4C	8,20	675		IE2
	3,8	9214	383,99	102306	1,6	KR874-3E112M/4D	8,05	661	192	IE3
	4,3	8165	339,70	105549	1,8	KR874-2E112M/4C	8,20	659		IE2
	5,1	6917	287,10	109020	2,2					
	6,2	5680	235,47	112301	2,6					

*: IE2 ve IE3 motorlu redüktör fiyatları farklıdır. / Geared motor prices are different for IE2 and IE3 motors. / Preise von Getrieben mit IE2 und IE3 Motoren sind unterschiedlich.

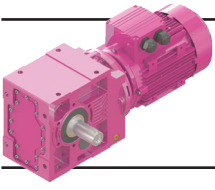

K Serisi Motorlu Güç Devir Sayfaları

K Series Geared Motors Performance Tables

K Serien Getriebemotoren Leistung und Drehzahlübersicht

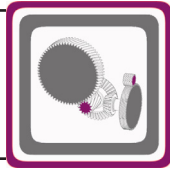

Güç	IE3 Çıkış Devri	IE3 Çıkış Momenti	Çevrim Oranı	IE3 Güv. Rad. Yük Çıkış	IE3 Servis Faktörü	Tipi	Anma Akımı	Ağırlık	Ölçü Sayfası	Motor Verim Snf.*
Power	Output Speeds	Output Torque	Ratio	Per.O. Loads (Output)	Service Factors	Type	Rated Current	Weight	Dim. Page	Motor Eff. Class
Leistung P _g [kW] P _g [HP]	Abtriebswelle Drehzahlen n ₂ [r.p.m]	Abtriebswelle Drehmomente M ₂ [Nm]	Übersetzung i	Zul.Querkräfte (Abtrieb) F _{qam} [N]	Betriebsfaktor f _s	Typ	Nennstrom [A]	Gewicht ~ [kg]	Maße Seite	Motor Effizienz-klasse
4,0 5,5	7,0	5024	207,95	113926	3,0	KR874-3E112M/4D KR874-2E112M/4C	8,05 8,20	661 659	192	IE3 IE2
	3,7 4,1 4,7 5,2 6,1 7,0 8,0	9497 8500 7478 6697 5785 5017 4394	396,00 354,32 311,14 278,35 240,71 208,42 182,29	44605 51831 57677 61629 65713 68775 70935	0,8 0,9 1,1 1,2 1,4 1,6 1,8	KR774-3E112M/4D KR774-2E112M/4C	8,05 8,20	394 392	180	IE3 IE2
4,0 5,5	8,7 9,8 11 13 15 17	4127 3664 3281 2835 2459 2153	111,63 99,00 88,57 76,59 66,32 58,00	71956 73471 74615 75970 76931 77814	1,9 2,2 2,4 2,8 3,3 3,7	KR773-3E132M/6C KR773-2E132M/6B	8,52 8,80	408 403	176	IE3 IE2
	7,6 9,6 11	4726 3721 3330	128,24 100,90 90,21	23751 33383 36197	0,9 1,2 1,3	KR673-3E132M/6C KR673-2E132M/6B	8,52 8,80	239 234	164	IE3 IE2
	11 14 16 18	3152 2482 2222 1982	128,24 100,90 90,21 80,38	37375 41219 42596 43675	1,4 1,7 1,9 2,2	KR673-3E112M/4D KR673-2E112M/4C	8,05 8,20	234 232	164	IE3 IE2
	13 15 18 22 25 28 33 38	2690 2383 2017 1655 1463 1302 1103 942	109,86 97,19 82,14 67,37 59,49 52,88 44,73 38,16	22797 25605 28440 30808 31921 32744 34132 35377	1,0 1,1 1,3 1,6 1,8 2,1 2,4 2,7	KR573-3E112M/4D KR573-2E112M/4C	8,05 8,20	165 163	152	IE3 IE2
	43 49	830 734	67,37 59,49	36050 36784	3,0 3,2	KR573-3E112M/2C KR573-2E112M/2A	7,28 7,50	161 157	152	IE3 IE2
	23 24 25 29 33 37 48 58 61 63 73 83	1577 1491 1454 1260 1099 964 746 625 590 576 499 436	64,17 60,63 59,19 51,22 44,64 39,11 30,11 25,15 23,76 23,19 20,07 17,49	16339 17138 17463 19013 20136 20986 22200 22635 22358 22241 21532 20857	1,0 1,0 1,1 1,2 1,4 1,6 2,1 2,5 2,6 2,7 3,0 3,3	KR473-3E112M/4D KR473-2E112M/4C	8,05 8,20	121 119	140	IE3 IE2
	34 39 43 51 59	1068 916 830 711 610	43,40 37,19 33,65 28,85 24,72	8204 10802 11934 13270 14241	0,8 0,9 1,0 1,2 1,3	KR373-3E112M/4D KR373-2E112M/4C	8,05 8,20	90 88	128	IE3 IE2

*: IE2 ve IE3 motorlu redüktör fiyatları farklıdır. / Geared motor prices are different for IE2 and IE3 motors. / Preise von Getrieben mit IE2 und IE3 Motoren sind unterschiedlich.

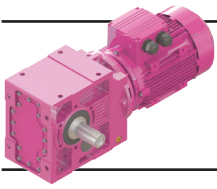

K Serisi Motorlu Güç Devir Sayfaları

K Series Geared Motors Performance Tables

K Serien Getriebemotoren Leistung und Drehzahlübersicht

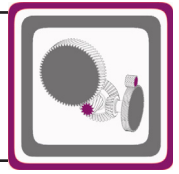

Güç	IE3 Çıkış Devri	IE3 Çıkış Momenti	Çevrim Oranı	IE3 Güv. Rad. Yük Çıkış	IE3 Servis Faktörü	Tipi	Anma Akımı	Ağırlık	Ölçü Sayfası	Motor Verim Snf.*
Power	Output Speeds	Output Torque	Ratio	Per.O. Loads (Output)	Service Factors	Type	Rated Current	Weight	Dim. Page	Motor Eff. Class
Leistung P _g [kW] P _g [HP]	Abtriebswelle Drehzahlen n ₂ [r.p.m]	Abtriebswelle Drehmomente M ₂ [Nm]	Übersetzung i	Zul.Querkräfte (Abtrieb) F _{qam} [N]	Betriebsfaktor f _s	Typ	Nennstrom [A]	Gewicht ~ [kg]	Maße Seite	Motor Effizienz-klasse
4,0 5,5	67	544	21,90	14785	1,5	KR373-3E112M/4D	8,05	90	128	IE3
	78	463	18,62	15412	1,8	KR373-2E112M/4C	8,20	88		IE2
	92	398	15,96	15882	2,1					
	101	360	14,44	16150	2,3					
	118	309	12,38	16476	2,7					
	138	265	10,60	16163	3,0					
	53	683	27,74	15437	0,9	KR283-3E112M/4D	8,05	64	116	IE3
	61	586	23,76	16110	1,0	KR283-2E112M/4C	8,20	63		IE2
	68	531	21,42	16463	1,1					
	80	452	18,21	16923	1,3					
	94	388	15,60	17258	1,5					
	103	351	14,12	16907	1,7					
	121	301	12,10	16357	1,9					
	141	258	10,37	15798	2,1					
	144	253	10,16	15368	1,5					
	169	215	8,63	14834	1,7					
	197	185	7,40	14321	1,9					
	218	167	6,70	13990	2,0					
	254	143	5,74	13482	2,3					
	297	123	4,92	12976	2,6					
5,5 7,5	63	571	23,08	11483	0,7	KR273-3E112M/4D	8,05	63	108	IE3
	77	473	19,08	12297	0,8	KR273-2E112M/4C	8,20	61		IE2
	92	395	15,92	12863	0,9					
	109	332	13,34	12762	1,1					
	122	297	12,00	12168	0,8					
	147	246	9,92	11817	1,0					
	176	206	8,28	11447	1,1					
	210	173	6,94	11066	1,3					
	218	166	13,34	12762	1,8	KR273-3E112M/2C	7,28	58	108	IE3
	243	149	12,00	12168	1,5	KR273-2E112M/2A	7,50	54		IE2
	294	124	9,92	11817	1,7					
	352	103	8,28	11447	1,9					
420	87	6,94	11066	2,2						
5,5 7,5	138	265	10,57	5261	0,9	KR202-3E112M/4D	8,05	56	104	IE3
	158	232	9,25	5021	1,0	KR202-2E112M/4C	8,20	54		IE2
	191	192	7,65	4688	1,1					
	229	160	6,38	4385	1,3					
	315	116	9,25	3892	1,6	KR202-3E112M/2C	7,28	53	104	IE3
	381	96	7,65	3625	1,8	KR202-2E112M/2A	7,50	48		IE2
457	80	6,38	3388	2,1						
5,5 7,5	2,0	23101	715,34	66223	0,9	KR975-3E132S/4C	10,65	1128	208	IE3
	2,2	21272	659,09	70837	0,9	KR975-2E132S/4B	11,05	1120		IE2
	2,5	18973	586,70	76058	1,1					
	2,8	16787	518,12	80320	1,2					
	3,2	14948	460,51	83679	1,3					
	3,4	13861	427,72	85556	1,4					
	4,0	11746	361,44	88672	1,7					
	3,7	13211	398,92	86458	1,5	KR974-3E132S/4C	10,65	1113	204	IE3
	4,1	11874	358,16	88481	1,7	KR974-2E132S/4B	11,05	1108		IE2
	4,8	10121	305,31	90923	2,0					
	5,4	8933	269,15	92450	2,2					
	6,1	7934	238,77	93799	2,5					

*: IE2 ve IE3 motorlu redüktör fiyatları farklıdır. / Geared motor prices are different for IE2 and IE3 motors. / Preise von Getrieben mit IE2 und IE3 Motoren sind unterschiedlich.

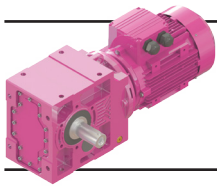

K Serisi Motorlu Güç Devir Sayfaları

K Series Geared Motors Performance Tables

K Serien Getriebemotoren Leistung und Drehzahlübersicht

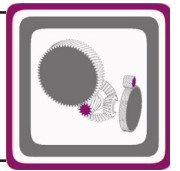

Güç	IE3 Çıkış Devri	IE3 Çıkış Momenti	Çevrim Oranı	IE3 Güv. Rad. Yük Çıkış	IE3 Servis Faktörü	Tipi	Anma Akımı	Ağırlık	Ölçü Sayfası	Motor Verim Snf.*	
Power	Output Speeds	Output Torque	Ratio	Per.O. Loads (Output)	Service Factors	Type	Rated Current	Weight	Dim. Page	Motor Eff. Class	
Leistung P _g [kW] P _g [HP]	Abtriebswelle Drehzahlen n ₂ [r.p.m]	Abtriebswelle Drehmomente M ₂ [Nm]	Übersetzung i	Zul.Querkräfte (Abtrieb) F _{qam} [N]	Betriebsfaktor f _s	Typ	Nennstrom [A]	Gewicht ~ [kg]	Maße Seite	Motor Effizienz-klasse	
5,5 7,5	8,0	6054	181,51	95993	3,3	KR974-3E132S/4C	10,65	1113	204	IE3	
	8,6 9,7	5631 5044	168,94 151,03	96458 97086	3,6 4,0	KR974-2E132S/4B	11,05	1108		IE2	
	4,3	11227	339,70	95138	1,3	KR874-3E132S/4C	10,65	660	192	IE3	
	5,1	9511	287,10	101336	1,6	KR874-2E132S/4B	11,05	654		IE2	
	6,2	7809	235,47	106545	1,9						
	7,0	6909	207,95	109108	2,2						
	8,4	5905	115,87	111829	2,5	KR873-3E132M/6D	11,55	652	188	IE3	
	9,4	5267	103,24	113495	2,8	KR873-2E132M/6C	12,00	647		IE2	
	10	4740	92,80	114627	3,2						
	12	4137	81,06	116023	3,6						
	5,2	9208	278,35	46845	0,9	KR774-3E132S/4C	10,65	429	180	IE3	
	6,1	7954	240,71	55019	1,0	KR774-2E132S/4B	11,05	423		IE2	
	7,0	6898	208,42	60535	1,2						
	8,0	6042	182,29	64522	1,3						
	8,7	5678	111,63	66155	1,4	KR773-3E132M/6D	11,55	407	176	IE3	
	9,8	5042	99,00	68574	1,6	KR773-2E132M/6C	12,00	402		IE2	
	11	4515	88,57	70527	1,8						
	13	3902	76,59	72638	2,1						
	13	3786	111,63	73041	2,1	KR773-3E132S/4C	10,65	399	176	IE3	
	15	3362	99,00	74380	2,4	KR773-2E132S/4B	11,05	393		IE2	
	16	3011	88,57	75433	2,7						
	19	2602	76,59	76614	3,1						
	22	2256	66,32	77554	3,5						
	11	4582	90,21	25491	0,9	KR673-3E132M/6D KR673-2E132M/6C	11,55 12,00	239 234	164	IE3 IE2	
	11	4334	128,24	28038	1,0	KR673-3E132S/4C	10,65	249	164	IE3	
	14	3413	100,90	35551	1,3	KR673-2E132S/4B	11,05	243		IE2	
	16	3055	90,21	37921	1,4						
	18	2725	80,38	39887	1,6						
	21	2320	68,47	42076	1,9						
	25	1998	58,86	43633	2,2						
	29	1736	51,08	44809	2,5						
	33	1520	44,65	45724	2,8						
		15	3276	97,19	15243	0,8	KR573-3E132S/4C	10,65	180	152	IE3
		18	2773	82,14	21892	1,0	KR573-2E132S/4B	11,05	174		IE2
22		2276	67,37	26421	1,2						
25		2012	59,49	28423	1,3						
28		1790	52,88	29925	1,5						
33		1517	44,73	32067	1,7						
38		1296	38,16	33803	1,9						
41		1199	35,34	34580	2,0						
	48	1028	30,25	35853	2,2						
	57	882	25,78	36406	2,6						
	64	780	22,77	37145	2,8						
	29	1732	51,22	14734	0,9	KR473-3E132S/4C	10,65	138	140	IE3	
33	1512	44,64	16950	1,0	KR473-2E132S/4B	11,05	132		IE2		

*: IE2 ve IE3 motorlu redüktör fiyatları farklıdır. / Geared motor prices are different for IE2 and IE3 motors. / Preise von Getrieben mit IE2 und IE3 Motoren sind unterschiedlich.

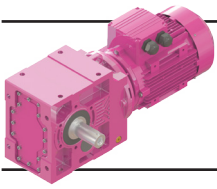

K Serisi Motorlu Güç Devir Sayfaları

K Series Geared Motors Performance Tables

K Serien Getriebemotoren Leistung und Drehzahlübersicht

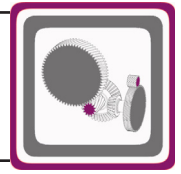

Güç	IE3 Çıkış Devri	IE3 Çıkış Momenti	Çevrim Oranı	IE3 Güv. Rad. Yük Çıkış	IE3 Servis Faktörü	Tipi	Anma Akımı	Ağırlık	Ölçü Sayfası	Motor Verim Sınıfı*	
Power	Output Speeds	Output Torque	Ratio	Per.O. Loads (Output)	Service Factors	Type	Rated Current	Weight	Dim. Page	Motor Eff. Class	
Leistung P _g [kW] P _g [HP]	Abtriebswelle Drehzahlen n ₂ [r.p.m]	Abtriebswelle Drehmomente M ₂ [Nm]	Übersetzung i	Zul.Querkräfte (Abtrieb) F _{qam} [N]	Betriebsfaktor f _s	Typ	Nennstrom [A]	Gewicht ~ [kg]	Maße Seite	Motor Effizienz- klasse	
5,5 7,5	37	1326	39,11	18473	1,2	KR473-3E132S/4C	10,65	138	140	IE3	
	48	1026	30,11	20584	1,5	KR473-2E132S/4B	11,05	132		IE2	
	58	859	25,15	21596	1,8						
	61	812	23,76	21378	1,9						
	63	792	23,19	21284	2,0						
	73	686	20,07	20704	2,2						
	83	599	17,49	20135	2,4						
	95	526	15,33	19577	2,6						
	106	469	13,71	18525	2,1						
	123	406	11,87	17983	2,4						
	141	355	10,34	17459	2,6						
	161	311	9,06	16950	2,9						
	195	258	7,48	16212	3,4						
		51	978	28,85	9843	0,8	KR373-3E132S/4C	10,65	103	128	IE3
		59	839	24,72	11823	1,0	KR373-2E132S/4B	11,05	97		IE2
67		748	21,90	12848	1,1						
78		637	18,62	13971	1,3						
92		547	15,96	14782	1,5						
101		495	14,44	15173	1,7						
118		424	12,38	15716	1,9						
138		364	10,60	15570	2,2						
146		342	9,97	15027	1,9						
171		293	8,54	14580	2,1						
189		266	7,73	14284	2,3						
220		228	6,63	13821	2,6						
257		195	5,68	13349	3,0						
		68	730	21,42	15076	0,8	KR283-3E132S/4C	10,65	84	116	IE3
		80	622	18,21	15873	1,0	KR283-2E132S/4B	11,05	82		IE2
	94	534	15,60	16345	1,1						
	103	483	14,12	16083	1,2						
	121	414	12,10	15653	1,4						
	141	355	10,37	15196	1,5						
	144	347	10,16	14644	1,1						
	169	296	8,63	14220	1,2						
	197	254	7,40	13797	1,4						
	218	230	6,70	13516	1,5						
	254	197	5,74	13076	1,7						
	297	169	4,92	12629	1,9						
		176	283	8,28	10737	0,8	KR273-3E132S/4C	10,65	82	108	IE3
		210	237	6,94	10471	0,9	KR273-2E132S/4B	11,05	77		IE2
		221	226	13,34	11775	1,3	KR273-3E132S/2B	9,90	73	108	IE3
297		168	9,92	10966	1,3	KR273-2E132S/2A	10,20	71		IE2	
356		140	8,28	10737	1,4						
425		118	6,94	10471	1,6						
7,5 10	2,7	24109	361,44	63458	0,8	KR975-3E160M/6D KR975-2E160M/6B	15,00 15,00	1210 1190	208	IE3 IE2	
	2,8	22813	518,12	67024	0,9	KR975-3E132M/4D	14,40	1135	208	IE3	
	3,2	20314	460,51	73062	1,0	KR975-2E132M/4C	15,00	1130		IE2	
	3,4	18836	427,72	76267	1,1						
	4,1	15963	361,44	81980	1,3						

*: IE2 ve IE3 motorlu redüktör fiyatları farklıdır. / Geared motor prices are different for IE2 and IE3 motors. / Preise von Getrieben mit IE2 und IE3 Motoren sind unterschiedlich.

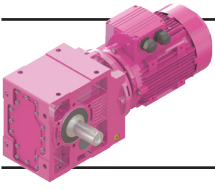

K Serisi Motorlu Güç Devir Sayfaları

K Series Geared Motors Performance Tables

K Serien Getriebemotoren Leistung und Drehzahlübersicht

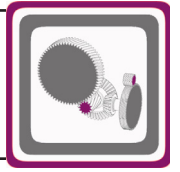

Güç	IE3 Çıkış Devri	IE3 Çıkış Momenti	Çevrim Oranı	IE3 Güv. Rad. Yük Çıkış	IE3 Servis Faktörü	Tipi	Anma Akımı	Ağırlık	Ölçü Sayfası	Motor Verim Snf.*
Power	Output Speeds	Output Torque	Ratio	Per.O. Loads (Output)	Service Factors	Type	Rated Current	Weight	Dim. Page	Motor Eff. Class
Leistung P _g [kW] P _g [HP]	Abtriebswelle Drehzahlen n ₂ [r.p.m]	Abtriebswelle Drehmomente M ₂ [Nm]	Übersetzung i	Zul.Querkräfte (Abtrieb) F _{qam} [N]	Betriebsfaktor f _s	Typ	Nennstrom [A]	Gewicht ~ [kg]	Maße Seite	Motor Effizienz-klasse
7,5 10	3,7	17954	398,92	78103	1,1	KR974-3E132M/4D	14,40	1120	204	IE3
	4,1	16136	358,16	81518	1,2	KR974-2E132M/4C	15,00	1112		IE2
	4,8	13754	305,31	85582	1,5					
	5,4	12140	269,15	88066	1,6					
	6,1	10783	238,77	90001	1,9					
	8,1	8227	181,51	93440	2,4					
	8,7	7653	168,94	94141	2,6					
	9,7	6855	151,03	94979	2,9					
	11	6119	134,57	95862	3,3					
		5,1	12925	287,10	88255	1,2	KR874-3E132M/4D	14,40	694	192
	6,2	10613	235,47	97408	1,4	KR874-2E132M/4B	15,00	689		IE2
	7,0	9389	207,95	101630	1,6					
	7,9	8358	184,83	104835	1,8					
	9,1	7308	161,34	107991	2,1					
	10	6457	142,32	110333	2,3					
	8,4	8054	115,87	105903	1,9	KR873-3E160M/6D	15,00	750	188	IE3
	9,4	7184	103,24	108410	2,1	KR873-2E160M/6B	15,00	750		IE2
	10	6465	92,80	110370	2,3					
	12	5643	81,06	112482	2,7					
	14	4933	70,76	114174	3,0					
	16	4358	62,42	115539	3,4					
	13	5352	115,87	113168	2,8	KR873-3E132M/4D	14,40	678	188	IE3
	14	4775	103,24	114564	3,1	KR873-2E132M/4C	15,00	673		IE2
	16	4297	92,80	115676	3,5					
	18	3751	81,06	116901	4,0					
	8,7	7745	111,63	56304	1,0	KR773-3E160M/6D	15,00	485	176	IE3
	9,8	6877	99,00	60758	1,2	KR773-2E160M/6B	15,00	485		IE2
	11	6159	88,57	64101	1,3					
	13	5322	76,59	67596	1,5					
	13	5147	111,63	68279	1,6	KR773-3E132M/4D	14,40	413	176	IE3
	15	4570	99,00	70363	1,8	KR773-2E132M/4C	15,00	408		IE2
	17	4093	88,57	72024	2,0					
	19	3537	76,59	73873	2,3					
	22	3068	66,32	75293	2,6					
	25	2687	58,00	76366	3,0					
	29	2372	51,13	77246	3,4					
	15	4640	100,90	24872	0,9	KR673-3E132M/4D	14,40	262	164	IE3
	16	4153	90,21	29758	1,0	KR673-2E132M/4C	15,00	257		IE2
	18	3705	80,38	33503	1,2					
	21	3154	68,47	37291	1,4					
	25	2716	58,86	39941	1,6					
	29	2360	51,08	41901	1,8					
	33	2066	44,65	43357	2,1					
	45	1519	32,68	45726	2,8					
	52	1308	28,10	46568	3,3					
	22	3094	67,37	18091	0,9	KR573-3E132M/4D	14,40	193	152	IE3
	25	2735	59,49	22291	1,0	KR573-2E132M/4C	15,00	188		IE2
	28	2434	52,88	25162	1,1					
	33	2062	44,73	28634	1,3					
	38	1761	38,16	31327	1,4					
	41	1630	35,34	32457	1,5					

*: IE2 ve IE3 motorlu redüktör fiyatları farklıdır. / Geared motor prices are different for IE2 and IE3 motors. / Preise von Getrieben mit IE2 und IE3 Motoren sind unterschiedlich.

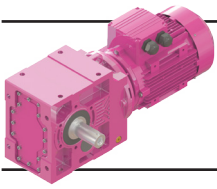

K Serisi Motorlu Güç Devir Sayfaları

K Series Geared Motors Performance Tables

K Serien Getriebemotoren Leistung und Drehzahlübersicht

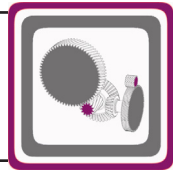

Güç	IE3 Çıkış Devri	IE3 Çıkış Momenti	Çevrim Oranı	IE3 Güv. Rad. Yük Çıkış	IE3 Servis Faktörü	Tipi	Anma Akımı	Ağırlık	Ölçü Sayfası	Motor Verim Sınıfı*	
Power	Output Speeds	Output Torque	Ratio	Per.O. Loads (Output)	Service Factors	Type	Rated Current	Weight	Dim. Page	Motor Eff. Class	
Leistung P _g [kW] P _g [HP]	Abtriebswelle Drehzahlen n ₂ [r.p.m]	Abtriebswelle Drehmomente M ₂ [Nm]	Übersetzung i	Zul.Querkräfte (Abtrieb) F _{qam} [N]	Betriebsfaktor f _s	Typ	Nennstrom [A]	Gewicht ~ [kg]	Maße Seite	Motor Effizienz-kategorie	
7,5 10	48	1397	30,25	34261	1,6	KR573-3E132M/4D	14,40	193	152	IE3	
	57	1199	25,78	35160	1,9	KR573-2E132M/4C	15,00	188		IE2	
	64	1060	22,77	36129	2,1						
	72	943	20,24	36931	2,2						
	78	875	18,80	37332	2,3						
	92	741	15,88	36353	2,6						
	108	632	13,53	34997	2,9						
	127	542	11,58	33696	3,1						
		37	1803	39,11	13919	0,9	KR473-3E132M/4D	14,40	151	140	IE3
		49	1395	30,11	17939	1,1	KR473-2E132M/4C	15,00	146		IE2
	58	1168	25,15	19645	1,3						
	62	1104	23,76	20070	1,4						
	63	1076	23,19	20007	1,4						
	73	933	20,07	19599	1,6						
	84	814	17,49	19172	1,7						
	96	715	15,33	18733	1,9						
	107	637	13,71	17560	1,6						
	123	553	11,87	17148	1,8						
	142	482	10,34	16731	1,9						
	162	423	9,06	16312	2,1						
	196	350	7,48	15685	2,5						
	236	291	6,21	15061	2,9						
	248	275	11,87	17148	2,8	KR473-3E132S/2C	13,20	134	140	IE3	
	285	240	10,34	16731	3,2	KR473-2E132S/2B	13,60	127		IE2	
	325	211	9,06	16312	3,5						
	67	1017	21,90	9185	0,8	KR373-3E132M/4D	14,40	118	128	IE3	
	79	866	18,62	11470	0,9	KR373-2E132M/4C	15,00	113		IE2	
	92	743	15,96	12926	1,1						
	101	673	14,44	13644	1,2						
	118	577	12,38	14526	1,4						
	138	495	10,60	14773	1,6						
	147	465	9,97	14152	1,4						
	172	399	8,54	13833	1,6						
	190	361	7,73	13609	1,7						
	221	310	6,63	13242	1,9						
	258	266	5,68	12854	2,2						
	278	247	10,60	14773	2,6	KR373-3E132S/2C	13,20	111	128	IE3	
	295	232	9,97	14152	2,3	KR373-2E132S/2B	13,60	104		IE2	
	345	199	8,54	13833	2,6						
	381	180	7,73	13609	2,8						
	444	154	6,63	13242	3,1						
	94	725	15,60	15113	0,8	KR283-3E132M/4D	14,40	90	116	IE3	
	104	657	14,12	14973	0,9	KR283-2E132M/4C	15,00	85		IE2	
	121	563	12,10	14705	1,0						
	141	483	10,37	14387	1,1						
	170	402	8,63	13397	0,9						
	198	345	7,40	13093	1,0						
	219	313	6,70	12880	1,1						
	255	268	5,74	12532	1,2						
	298	230	4,92	12163	1,4						
	341	201	8,63	13397	1,4	KR283-3E132S/2C	13,20	82	116	IE3	
	398	172	7,40	13093	1,6	KR283-2E132S/2B	13,60	77		IE2	
	440	156	6,70	12880	1,8						

*: IE2 ve IE3 motorlu redüktör fiyatları farklıdır. / Geared motor prices are different for IE2 and IE3 motors. / Preise von Getrieben mit IE2 und IE3 Motoren sind unterschiedlich.

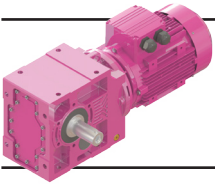

K Serisi Motorlu Güç Devir Sayfaları

K Series Geared Motors Performance Tables

K Serien Getriebemotoren Leistung und Drehzahlübersicht

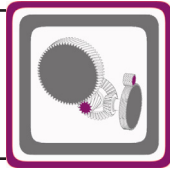

Güç	IE3 Çıkış Devri	IE3 Çıkış Momenti	Çevrim Oranı	IE3 Güv. Rad. Yük Çıkış	IE3 Servis Faktörü	Tipi	Anma Akımı	Ağırlık	Ölçü Sayfası	Motor Verim Snf.*
Power	Output Speeds	Output Torque	Ratio	Per.O. Loads (Output)	Service Factors	Type	Rated Current	Weight	Dim. Page	Motor Eff. Class
Leistung P _g [kW] P _g [HP]	Abtriebswelle Drehzahlen n ₂ [r.p.m]	Abtriebswelle Drehmomente M ₂ [Nm]	Übersetzung i	Zul.Querkräfte (Abtrieb) F _{qam} [N]	Betriebsfaktor f _s	Typ	Nennstrom [A]	Gewicht ~ [kg]	Maße Seite	Motor Effizienz-klasse
7,5 10	185	368	15,92	10344	0,8	KR273-3E132S/2C	13,20	77	108	IE3
	221	309	13,34	10459	1,0	KR273-2E132S/2B	13,60	71		IE2
	297	229	9,92	9831	0,9					
	356	192	8,28	9791	1,0					
	425	161	6,94	9677	1,2					
11 15	5,3	18223	181,51	77521	1,1	KR974-3E160L/6E	21,50	1211	204	IE3
	5,7	16952	168,94	80002	1,2	KR974-2E160L/6D	22,00	1195		IE2
	6,4	15184	151,03	83191	1,3					
	7,2	13555	134,57	85901	1,5					
	8,1	12025	181,51	88228	1,7	KR974-3E160M/4C	21,00	1196	204	IE3
	8,7	11186	168,94	89439	1,8	KR974-2E160M/4B	21,00	1186		IE2
	9,7	10020	151,03	91079	2,0					
	11	8945	134,57	92510	2,2					
	10	9873	146,20	91267	2,0	KR973-3E160M/4C	21,00	1176	200	IE3
	11	8817	130,38	92669	2,3	KR973-2E160M/4B	21,00	1170		IE2
	13	7943	117,32	93772	2,5					
	14	7027	103,87	94873	2,8					
	16	6156	90,85	95873	3,2					
	18	5450	80,31	96733	3,7					
	21	4865	71,60	97866	4,0					
	8,0	12217	184,83	91409	1,2	KR874-3E160M/4C	21,00	762	192	IE3
	9,1	10683	161,34	97286	1,4	KR874-2E160M/4B	21,00	772		IE2
	10	9438	142,32	101572	1,6					
	8,4	11819	115,87	93008	1,3	KR873-3E160L/6E	21,50	766	188	IE3
9,4	10543	103,24	97791	1,4	KR873-2E160L/6D	22,00	766		IE2	
10	9488	92,80	101239	1,6						
12	8282	81,06	105084	1,8						
12	8213	115,87	105498	1,8	KR873-3E160M/4C	21,00	741	188	IE3	
14	7327	103,24	108095	2,0	KR873-2E160M/4B	21,00	751		IE2	
15	6593	92,80	110090	2,3						
17	5756	81,06	112392	2,6						
20	5032	70,76	114064	3,0						
22	4445	62,42	115398	3,4						
11	9038	88,57	48219	0,9	KR773-3E160L/6E	21,50	450	176	IE3	
13	7810	76,59	55843	1,0	KR773-2E160L/6D	22,00	450		IE2	
13	7525	111,63	57419	1,1	KR773-3E160M/4C	21,00	476	176	IE3	
15	6682	99,00	61698	1,2	KR773-2E160M/4B	21,00	486		IE2	
17	5984	88,57	64860	1,3						
19	5172	76,59	68181	1,5						
22	4485	66,32	70695	1,8						
25	3928	58,00	72610	2,0						
29	3468	51,13	74086	2,3						
32	3080	45,36	73382	2,6						
36	2749	40,44	71725	2,9						
38	2649	39,00	71192	3,0						
44	2298	33,78	69061	3,5						

*: IE2 ve IE3 motorlu redüktör fiyatları farklıdır. / Geared motor prices are different for IE2 and IE3 motors. / Preise von Getrieben mit IE2 und IE3 Motoren sind unterschiedlich.

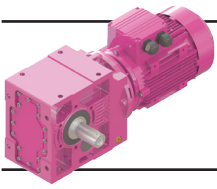

K Serisi Motorlu Güç Devir Sayfaları

K Series Geared Motors Performance Tables

K Serien Getriebemotoren Leistung und Drehzahlübersicht

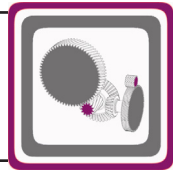

Güç	IE3 Çıkış Devri	IE3 Çıkış Momenti	Çevrim Oranı	IE3 Güv. Rad. Yük Çıkış	IE3 Servis Faktörü	Tipi	Anma Akımı	Ağırlık	Ölçü Sayfası	Motor Verim Snf.*	
Power	Output Speeds	Output Torque	Ratio	Per.O. Loads (Output)	Service Factors	Type	Rated Current	Weight	Dim. Page	Motor Eff. Class	
Leistung P _g [kW] P _g [HP]	Abtriebswelle Drehzahlen n ₂ [r.p.m]	Abtriebswelle Drehmomente M ₂ [Nm]	Übersetzung i	Zul.Querkräfte (Abtrieb) F _{qam} [N]	Betriebsfaktor f _s	Typ	Nennstrom [A]	Gewicht ~ [kg]	Maße Seite	Motor Effizienz- klasse	
11 15	21	4612	68,47	25154	0,9	KR673-3E160M/4C KR673-2E160M/4B	21,00	322	164	IE3	
	25	3971	58,86	31365	1,1		21,00	332		IE2	
	29	3451	51,08	35367	1,2						
	33	3021	44,65	38196	1,4						
	37	2659	39,26	40310	1,6						
	45	2221	32,68	42597	1,9						
	52	1913	28,10	44063	2,2						
	60	1663	24,38	45097	2,6						
	69	1456	21,32	45997	3,0						
	78	1281	18,74	46687	3,4						
	33	3015	44,73	20090	0,9	KR573-3E160M/4C KR573-2E160M/4B	21,00	257	152	IE3	
	39	2575	38,16	25664	1,0		21,00	267		IE2	
	42	2383	35,34	27743	1,0						
	49	2042	30,25	30881	1,1						
	57	1752	25,78	32523	1,3						
	65	1550	22,77	34000	1,4						
	73	1379	20,24	35220	1,5						
	78	1279	18,80	35839	1,6						
	93	1083	15,88	34717	1,8						
	109	924	13,53	33604	2,0						
127	792	11,58	32503	2,1							
131	764	11,22	31906	1,9							
155	647	9,48	30758	2,1							
182	552	8,07	29654	2,4							
213	473	6,91	28586	2,6							
63 73 84 96 107 124 142 162 196 237	1574	23,19	16370	1,0	KR473-3E160M/4C KR473-2E160M/4B	21,00	214	140	IE3		
	1364	20,07	17666	1,1		21,00	224		IE2		
	1191	17,49	17487	1,2							
	1045	15,33	17257	1,3							
	932	13,71	15872	1,1							
	808	11,87	15688	1,2							
	705	10,34	15458	1,3							
	619	9,06	15197	1,5							
	512	7,48	14764	1,7							
	426	6,21	14296	1,9							
	15 20	6,5	20600	151,03	72487	1,0	KR974-3E180L/6E KR974-2E180L/6D	29,00	1255	204	IE3
		7,3	18389	134,57	77184	1,1		29,00	1243		IE2
		8,1	16397	181,51	81033	1,2	KR974-3E160L/4D KR974-2E160L/4C	29,00	1205	204	IE3
8,7		15253	168,94	83074	1,3	29,30		1195	IE2		
9,7		13663	151,03	85735	1,5						
11		12197	134,57	88015	1,6						
10		13466	146,20	86045	1,5	KR973-3E160L/4D KR973-2E160L/4C	29,00	1187	200	IE3	
11		12025	130,38	88268	1,7		29,30	1182		IE2	
13		10833	117,32	89994	1,8						
14		9585	103,87	91699	2,1						
16	8396	90,85	93346	2,4							
18	7433	80,31	94462	2,7							
21	6635	71,60	95361	3,0							
23	5964	64,28	96166	3,3							
27	5086	54,80	97370	3,9							
9,4	14306	103,24	82207	1,0	KR873-3E180L/6E KR873-2E180L/6D	29,00	809	188	IE3		
11	12874	92,80	88673	1,2		29,00	789		IE2		
12	11237	81,06	95249	1,3							

*: IE2 ve IE3 motorlu redüktör fiyatları farklıdır. / Geared motor prices are different for IE2 and IE3 motors. / Preise von Getrieben mit IE2 und IE3 Motoren sind unterschiedlich.

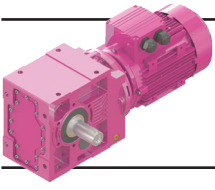

K Serisi Motorlu Güç Devir Sayfaları

K Series Geared Motors Performance Tables

K Serien Getriebemotoren Leistung und Drehzahlübersicht

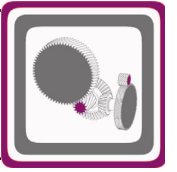

Güç	IE3 Çıkış Devri	IE3 Çıkış Momenti	Çevrim Oranı	IE3 Güv. Rad. Yük Çıkış	IE3 Servis Faktörü	Tipi	Anma Akımı	Ağırlık	Ölçü Sayfası	Motor* Verim Snf.	
Power	Output Speeds	Output Torque	Ratio	Per.O. Loads (Output)	Service Factors	Type	Rated Current	Weight	Dim. Page	Motor Eff. Class	
Leistung P _g [kW] P _g [HP]	Abtriebswelle Drehzahlen n ₂ [r.p.m]	Abtriebswelle Drehmomente M ₂ [Nm]	Übersetzung i	Zul.Querkräfte (Abtrieb) F _{qam} [N]	Betriebsfaktor f _s	Typ	Nennstrom [A]	Gewicht ~ [kg]	Maße Seite	Motor Effizienz- klasse	
15 20	13	10673	115,87	97450	1,4	KR873-3E160L/4D	29,00	766	188	IE3	
	14	9522	103,24	101404	1,6	KR873-2E160L/4C	29,30	763		IE2	
	16	8569	92,80	104431	1,8						
	18	7480	81,06	107574	2,0						
	21	6540	70,76	110229	2,3						
	24	5778	62,42	112156	2,6						
	26	5147	55,53	113745	2,9						
30	4616	49,75	114934	3,2							
15 17 19 22 25 29 32 36 38 44 50 55 62	15	9113	99,00	47536	0,9	KR773-3E160L/4D	29,00	501	176	IE3	
	17	8162	88,57	53663	1,0	KR773-2E160L/4C	29,30	498		IE2	
	19	7054	76,59	59800	1,1						
	22	6117	66,32	64248	1,3						
	25	5358	58,00	67449	1,5						
	29	4730	51,13	69758	1,7						
	32	4201	45,36	69360	1,9						
	36	3750	40,44	68138	2,1						
	38	3613	39,00	67733	2,2						
	44	3134	33,78	66065	2,6						
	50	2731	29,40	64367	2,9						
	55	2468	26,52	63065	3,2						
	62	2193	23,52	61523	3,6						
	29 33 37 45 52 60 69 78 89 101 118 136 156 177	29	4707	51,08	23948	0,9	KR673-3E160L/4D	29,00	363	164	IE3
33		4120	44,65	30057	1,0	KR673-2E160L/4C	29,30	360		IE2	
37		3627	39,26	34185	1,2						
45		3030	32,68	38205	1,4						
52		2609	28,10	40633	1,6						
60		2268	24,38	42359	1,9						
69		1986	21,32	43740	2,2						
78		1748	18,74	44807	2,5						
89		1545	16,54	45641	2,8						
101		1347	14,49	50991	2,2						
118		1161	12,46	50192	2,4						
136		1009	10,81	48599	2,7						
156		883	9,45	47088	2,9						
177		778	8,31	45648	3,2						
57 65 73 78 93 109 127 131 155 182 213	57	2390	25,78	28613	1,0	KR573-3E160L/4D	29,00	281	152	IE3	
	65	2114	22,77	31047	1,0	KR573-2E160L/4C	29,30	278		IE2	
	73	1881	20,24	32895	1,1						
	78	1745	18,80	33626	1,2						
	93	1477	15,88	32847	1,3						
	109	1260	13,53	32012	1,4						
	127	1080	11,58	31140	1,6						
	131	1043	11,22	30448	1,4						
	155	883	9,48	29526	1,6						
	182	753	8,07	28605	1,7						
	213	646	6,91	27688	1,9						
	84 96 107 124 142 162 196 237	84	1624	17,49	15562	0,9	KR473-3E160L/4D	29,00	240	140	IE3
		96	1425	15,33	15570	1,0	KR473-2E160L/4C	29,30	237		IE2
		107	1271	13,71	13943	0,8					
124		1102	11,87	14018	0,9						
142		962	10,34	14003	1,0						
162		844	9,06	13922	1,1						
196		699	7,48	13711	1,2						
237		581	6,21	13422	1,4						

*: IE2 ve IE3 motorlu redüktör fiyatları farklıdır. / Geared motor prices are different for IE2 and IE3 motors. / Preise von Getrieben mit IE2 und IE3 Motoren sind unterschiedlich.

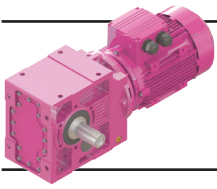

K Serisi Motorlu Güç Devir Sayfaları

K Series Geared Motors Performance Tables

K Serien Getriebemotoren Leistung und Drehzahlübersicht

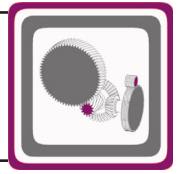

Güç	IE3 Çıkış Devri	IE3 Çıkış Momenti	Çevrim Oranı	IE3 Güv. Rad. Yük Çıkış	IE3 Servis Faktörü	Tipi	Anma Akımı	Ağırlık	Ölçü Sayfası	Motor Verim Snf.*
Power	Output Speeds	Output Torque	Ratio	Per.O. Loads (Output)	Service Factors	Type	Rated Current	Weight	Dim. Page	Motor Eff. Class
Leistung P _g [kW] P _g [HP]	Abtriebswelle Drehzahlen n ₂ [r.p.m.]	Abtriebswelle Drehmomente M ₂ [Nm]	Übersetzung i	Zul.Querkräfte (Abtrieb) F _{qam} [N]	Betriebsfaktor f _s	Typ	Nennstrom [A]	Gewicht ~ [kg]	Maße Seite	Motor Effizienz- klasse
18,5 25	9,4	17756	103,87	78589	1,1	KR973-3E200L/6C KR973-2E200L/6B	36,40 36,50	1276 1256	200	IE3 IE2
	9,8 11	16794 14992	151,03 134,57	80303 83537	1,2 1,3	KR974-3E180M/4C KR974-2E180M/4B	34,50 34,50	1242 1232	204	IE3 IE2
	11 13 14 16 18 21 23 27 31 34	14782 13317 11782 10321 9137 8156 7332 6252 5519 4902	130,38 117,32 103,87 90,85 80,31 71,60 64,28 54,80 48,31 42,86	83894 86297 88638 90798 92332 93547 94602 96091 96916 97720	1,4 1,5 1,7 1,9 2,2 2,5 2,7 3,2 3,6 4,0	KR973-3E180M/4C KR973-2E180M/4B	34,50 34,50	1224 1214	200	IE3 IE2
	13 15	12640 10983	113,42 98,53	89656 96189	1,2 1,4	KR874-3E180M/4C KR874-2E180M/4B	34,50 34,50	821 821	192	IE3 IE2
	12 14	13858 12115	81,06 70,76	84247 91801	1,1 1,2	KR873-3E200L/6C KR873-2E200L/6B	36,40 36,50	807 807	188	IE3 IE2
	14 16 18 21 24 27 30 34 39	11704 10533 9195 8040 7102 6327 5674 4930 4341	103,24 92,80 81,06 70,76 62,42 55,53 49,75 43,22 38,00	93451 97821 102364 105817 108630 110730 112387 114806 112515	1,3 1,4 1,6 1,9 2,1 2,4 2,6 3,0 3,3	KR873-3E180M/4C KR873-2E180M/4B	34,50 34,50	804 804	188	IE3 IE2
	19 22 25 29 33 36 38 44 50 56 63 70 73	8671 7520 6586 5814 5164 4610 4441 3853 3358 3034 2695 2406 2318	76,59 66,32 58,00 51,13 45,36 40,44 39,00 33,78 29,40 26,52 23,52 20,97 20,23	50588 57472 62026 65570 65841 65000 64707 63444 62085 61007 59698 58398 57978	0,9 1,1 1,2 1,4 1,5 1,7 1,8 2,1 2,4 2,6 3,0 3,3 3,4	KR773-3E180M/4C KR773-2E180M/4B	34,50 34,50	537 537	176	IE3 IE2
	33 38 45 52 60 69 79 89 102 118 136 156	5065 4458 3724 3207 2788 2441 2149 1899 1656 1427 1240 1086	44,65 39,26 32,68 28,10 24,38 21,32 18,74 16,54 14,49 12,46 10,81 9,45	19115 26817 33355 37015 39559 41471 42949 44104 50128 48913 47488 46117	0,8 1,0 1,2 1,3 1,5 1,8 2,0 2,3 1,8 2,0 2,2 2,4	KR673-3E180M/4C KR673-2E180M/4B	34,50 34,50	399 399	164	IE3 IE2

*: IE2 ve IE3 motorlu redüktör fiyatları farklıdır. / Geared motor prices are different for IE2 and IE3 motors. / Preise von Getrieben mit IE2 und IE3 Motoren sind unterschiedlich.

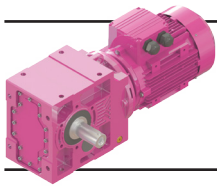

K Serisi Motorlu Güç Devir Sayfaları

K Series Geared Motors Performance Tables

K Serien Getriebemotoren Leistung und Drehzahlübersicht

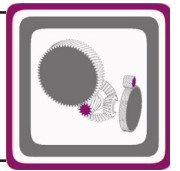

Güç	IE3 Çıkış Devri	IE3 Çıkış Momenti	Çevrim Oranı	IE3 Güv. Rad. Yük Çıkış	IE3 Servis Faktörü	Tipi	Anma Akımı	Ağırlık	Ölçü Sayfası	Motor Verim Snf.*						
Power	Output Speeds	Output Torque	Ratio	Per.O. Loads (Output)	Service Factors	Type	Rated Current	Weight	Dim. Page	Motor Eff. Class						
Leistung P _g [kW] P _g [HP]	Abtriebswelle Drehzahlen n ₂ [r.p.m]	Abtriebswelle Drehmomente M ₂ [Nm]	Übersetzung i	Zul.Querkräfte (Abtrieb) F _{qam} [N]	Betriebsfaktor f _s	Typ	Nennstrom [A]	Gewicht ~ [kg]	Maße Seite	Motor Effizienz-klasse						
18,5 25	178	956	8,31	44795	2,6	KR673-3E180M/4C KR673-2E180M/4B	34,50 34,50	399 399	164	IE3 IE2						
	65	2598	22,77	27790	0,8	KR573-3E180M/4C KR573-2E180M/4B	34,50 34,50	321 321	152	IE3 IE2						
	73	2313	20,24	30454	0,9											
	78	2145	18,80	31689	1,0											
	93	1816	15,88	31210	1,1											
	109	1549	13,53	30618	1,2											
	127	1328	11,58	29948	1,3											
	131	1282	11,22	29173	1,1											
	156	1085	9,48	28449	1,3											
	183	926	8,07	27687	1,4											
	213	794	6,91	26903	1,5											
	22 30	163	1038	9,06	12807	0,9	KR473-3E180M/4C KR473-2E180M/4B	34,50 34,50	279 279	140	IE3 IE2					
		197	859	7,48	12790	1,0	KR974-3E180L/4D KR974-2E180L/4C	42,50 42,50	1257 1237	204	IE3 IE2					
		11	17828	134,57	78422	1,1										
		11	17580	130,38	78801	1,1										
13		15837	117,32	82203	1,3											
14		14012	103,87	85289	1,4											
16		12275	90,85	87970	1,6											
18		10866	80,31	89989	1,8											
21		9700	71,60	91565	2,1											
23		8719	64,28	92904	2,3											
27		7436	54,80	94720	2,7											
31		6564	48,31	95768	3,0											
34		5830	42,86	96672	3,4											
47		4314	31,63	100450	4,0											
22 30		12	16483	81,06	70303	0,9						KR873-3E200L/6D KR873-2E200L/6C	42,50 43,00	827 827	188	IE3 IE2
	14	14410	70,76	81609	1,0	KR873-3E180L/4D KR873-2E180L/4C	42,50 42,50	844 844	188	IE3 IE2						
	14	13920	103,24	83967	1,1											
	16	12527	92,80	90131	1,2											
	18	10936	81,06	96365	1,4											
	21	9561	70,76	101165	1,6											
	24	8447	62,42	104716	1,8											
	27	7524	55,53	107357	2,0											
	30	6748	49,75	109595	2,2											
	34	5864	43,22	112553	2,5											
	39	5163	38,00	110238	2,8											
	43	4664	34,28	107854	3,0											
	22 30	22	8943	66,32	48734						0,9	KR773-3E180L/4D KR773-2E180L/4C	42,50 42,50	578 578	176	IE3 IE2
		25	7833	58,00	55713						1,0	KR773-3E180L/4D KR773-2E180L/4C	42,50 42,50	578 578	176	IE3 IE2
		29	6915	51,13	60547						1,2					
33		6142	45,36	62321	1,3											
36		5482	40,44	61862	1,5											
38		5282	39,00	61681	1,5											
44		4582	33,78	60823	1,7											
50		3993	29,40	59804	2,0											
56		3609	26,52	58950	2,2											
63		3206	23,52	57873	2,5											
70		2862	20,97	56770	2,8											

*: IE2 ve IE3 motorlu redüktör fiyatları farklıdır. / Geared motor prices are different for IE2 and IE3 motors. / Preise von Getrieben mit IE2 und IE3 Motoren sind unterschiedlich.

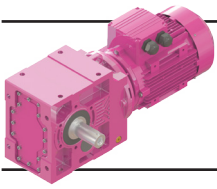

K Serisi Motorlu Güç Devir Sayfaları

K Series Geared Motors Performance Tables

K Serien Getriebemotoren Leistung und Drehzahlübersicht

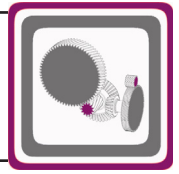

Güç	IE3 Çıkış Devri	IE3 Çıkış Momenti	Çevrim Oranı	IE3 Güv. Rad. Yük Çıkış	IE3 Servis Faktörü	Tipi	Anma Akımı	Ağırlık	Ölçü Sayfası	Motor Verim Snf.*	
Power	Output Speeds	Output Torque	Ratio	Per.O. Loads (Output)	Service Factors	Type	Rated Current	Weight	Dim. Page	Motor Eff. Class	
Leistung P _g [kW] P _g [HP]	Abtriebswelle Drehzahlen n ₂ [r.p.m]	Abtriebswelle Drehmomente M ₂ [Nm]	Übersetzung i	Zul.Querkräfte (Abtrieb) F _{qam} [N]	Betriebsfaktor f _s	Typ	Nennstrom [A]	Gewicht ~ [kg]	Maße Seite	Motor Effizienz-klasse	
22 30	73	2757	20,23	56409	2,9	KR773-3E180L/4D	42,50	578	176	IE3	
	84	2392	17,52	54934	3,2	KR773-2E180L/4C	42,50	578		IE2	
	97	2085	15,25	53450	3,5						
	45	4429	32,68	27119	1,0	KR673-3E180L/4D	42,50	439	164	IE3	
	52	3815	28,10	32647	1,1	KR673-2E180L/4C	42,50	439		IE2	
	60	3316	24,38	36295	1,3						
	69	2903	21,32	38906	1,5						
	79	2556	18,74	40876	1,7						
	89	2259	16,54	42403	1,9						
	102	1970	14,49	48904	1,5						
	118	1697	12,46	47633	1,7						
	136	1475	10,81	46378	1,8						
	156	1291	9,45	45147	2,0						
	178	1137	8,31	43941	2,2						
	30 40	93	2160	15,88	29574	0,9	KR573-3E180L/4D	42,50	361	152	IE3
		109	1842	13,53	29225	1,0	KR573-2E180L/4C	42,50	361		IE2
		127	1580	11,58	28755	1,1					
		131	1525	11,22	27898	1,0					
156		1291	9,48	27371	1,1						
183		1101	8,07	26769	1,2						
213		944	6,91	26117	1,3						
197		1021	7,48	11869	0,8	KR473-3E180L/4D	42,50	319	140	IE3	
237		849	6,21	11893	1,0	KR473-2E180L/4C	42,50	319		IE2	
30 40		14	19734	71,60	74360	1,0	KR973-3E225S/6C	57,60	1378	200	IE3
							KR973-2E225S/6B	57,60	1353		IE2
		14	19108	103,87	75727	1,0	KR973-3E200L/4D	54,50	1306	200	IE3
		16	16740	90,85	80436	1,2	KR973-2E200L/4C	55,50	1281		IE2
		18	14819	80,31	83854	1,3					
		21	13229	71,60	86448	1,5					
		23	11891	64,28	88571	1,7					
		27	10140	54,80	91289	2,0					
		31	8952	48,31	92916	2,2					
	34	7951	42,86	94262	2,5						
	39	7098	38,21	95385	2,7						
	47	5883	31,63	96858	3,3						
	53	5194	27,88	97679	3,7						
	30 40	18	14913	81,06	79086	1,0	KR873-3E200L/4D	54,50	868	188	IE3
		21	13039	70,76	87943	1,2	KR873-2E200L/4C	55,50	855		IE2
		24	11519	62,42	94173	1,3					
		27	10261	55,53	98787	1,5					
		30	9203	49,75	102239	1,6					
34		7997	43,22	106655	1,8						
39		7041	38,00	105031	2,0						
43		6361	34,28	103156	2,2						
49		5550	29,88	100537	2,4						
61		4516	24,28	96417	3,1						
30 40		33	8376	45,36	52467	1,0	KR773-3E200L/4D	54,50	601	176	IE3
		36	7477	40,44	54688	1,1	KR773-2E200L/4C	55,50	588		IE2
		38	7204	39,00	54764	1,1					
		44	6249	33,78	54831	1,3					
		50	5446	29,40	54590	1,5					
		56	4922	26,52	54247	1,6					

*: IE2 ve IE3 motorlu redüktör fiyatları farklıdır. / Geared motor prices are different for IE2 and IE3 motors. / Preise von Getrieben mit IE2 und IE3 Motoren sind unterschiedlich.

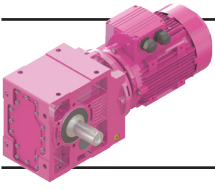

K Serisi Motorlu Güç Devir Sayfaları

K Series Geared Motors Performance Tables

K Serien Getriebemotoren Leistung und Drehzahlübersicht

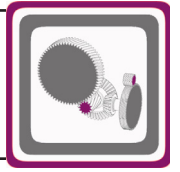

Güç	IE3 Çıkış Devri	IE3 Çıkış Momenti	Çevrim Oranı	IE3 Güv. Rad. Yük Çıkış	IE3 Servis Faktörü	Tipi	Anma Akımı	Ağırlık	Ölçü Sayfası	Motor Verim Snf.*	
Power	Output Speeds	Output Torque	Ratio	Per.O. Loads (Output)	Service Factors	Type	Rated Current	Weight	Dim. Page	Motor Eff. Class	
Leistung P _g [kW] P _g [HP]	Abtriebswelle Drehzahlen n ₂ [r.p.m]	Abtriebswelle Drehmomente M ₂ [Nm]	Übersetzung i	Zul.Querkräfte (Abtrieb) F _{qam} [N]	Betriebsfaktor f _s	Typ	Nennstrom [A]	Gewicht ~ [kg]	Maße Seite	Motor Effizienz-klasse	
30 40	63	4372	23,52	53701	1,8	KR773-3E200L/4D	54,50	601	176	IE3	
	70	3903	20,97	53050	2,0	KR773-2E200L/4C	55,50	588		IE2	
	73	3760	20,23	52822	2,1						
	84	3262	17,52	51826	2,3						
	97	2843	15,25	50746	2,6						
	114	2398	12,89	47780	1,9						
	129	2130	11,44	46879	2,1						
	145	1902	10,20	45962	2,2						
	150	1832	9,83	45662	2,3						
	173	1590	8,52	44444	2,5						
	199	1385	7,41	43223	2,8						
	60 69 79 89 102 118 136 156 178	60	4522	24,38	26181	1,0	KR673-3E200L/4D	54,50	460	164	IE3
		69	3959	21,32	31466	1,1	KR673-2E200L/4C	55,50	447		IE2
		79	3485	18,74	35118	1,2					
		89	3081	16,54	37819	1,4					
		102	2687	14,49	45501	1,1					
		118	2314	12,46	44708	1,2					
		136	2012	10,81	43839	1,3					
		156	1761	9,45	42927	1,5					
178		1551	8,31	41990	1,6						
37 50		18	18616	54,80	76726	1,1	KR973-3E250M/6C	68,80	1498	200	IE3
		20	16433	48,31	81083	1,2	KR973-2E250M/6B	69,60	1438		IE2
21 23 27 31 34 39 47 53 60 67 79 89 101 113 126		21	16316	71,60	81198	1,2	KR973-3E225S/4C	65,70	1368	200	IE3
		23	14666	64,28	84198	1,4	KR973-2E225S/4B	66,00	1343		IE2
	27	12507	54,80	87908	1,6						
	31	11041	48,31	90137	1,8						
	34	9807	42,86	91937	2,0						
	39	8755	38,21	93411	2,2						
	47	7257	31,63	95336	2,7						
	53	6406	27,88	96509	3,0						
	60	5691	24,73	97284	3,4						
	67	5080	22,05	97963	3,8						
	79	4306	18,73	103765	2,9						
	89	3802	16,51	104464	3,2						
	101	3377	14,65	101735	3,5						
	113	3015	13,06	98859	3,8						
	126	2702	11,69	96118	4,0						
	27 30 34 39 43 49 61 69 77 88 106 120 133	27	12656	55,53	89463	1,2	KR873-3E225S/4C	65,70	970	188	IE3
		30	11351	49,75	94671	1,3	KR873-2E225S/4B	66,00	954		IE2
34		9864	43,22	100882	1,5						
39		8685	38,00	100472	1,6						
43		7845	34,28	99043	1,8						
49		6846	29,88	96954	1,9						
61		5570	24,28	93506	2,5						
69		4904	21,34	91240	2,8						
77		4430	19,26	89380	3,0						
88		3866	16,78	86841	3,3						
106		3203	13,93	82152	2,7						
120		2820	12,25	79871	3,0						
133		2547	11,05	78039	3,2						
44 50 56 63 70	44	7708	33,78	49588	1,0	KR773-3E225S/4C	65,70	693	176	IE3	
	50	6717	29,40	50027	1,2	KR773-2E225S/4B	66,00	677		IE2	
	56	6071	26,52	50131	1,3						
	63	5393	23,52	50050	1,5						
	70	4814	20,97	49795	1,7						

*: IE2 ve IE3 motorlu redüktör fiyatları farklıdır. / Geared motor prices are different for IE2 and IE3 motors. / Preise von Getrieben mit IE2 und IE3 Motoren sind unterschiedlich.

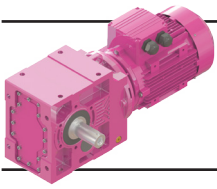

K Serisi Motorlu Güç Devir Sayfaları

K Series Geared Motors Performance Tables

K Serien Getriebemotoren Leistung und Drehzahlübersicht

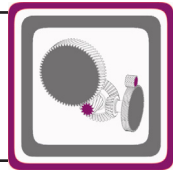

Güç	IE3 Çıkış Devri	IE3 Çıkış Momenti	Çevrim Oranı	IE3 Güv. Rad. Yük Çıkış	IE3 Servis Faktörü	Tipi	Anma Akımı	Ağırlık	Ölçü Sayfası	Motor Verim Snf.*	
Power	Output Speeds	Output Torque	Ratio	Per.O. Loads (Output)	Service Factors	Type	Rated Current	Weight	Dim. Page	Motor Eff. Class	
Leistung P _g [kW] P _g [HP]	Abtriebswelle Drehzahlen n ₂ [r.p.m]	Abtriebswelle Drehmomente M ₂ [Nm]	Übersetzung i	Zul.Querkräfte (Abtrieb) F _{qam} [N]	Betriebsfaktor f _s	Typ	Nennstrom [A]	Gewicht ~ [kg]	Maße Seite	Motor Effizienz- klasse	
37 50	73	4638	20,23	49683	1,7	KR773-3E225S/4C	65,70	693	176	IE3	
	84	4024	17,52	49108	1,9	KR773-2E225S/4B	66,00	677		IE2	
	97	3507	15,25	48380	2,1						
	114	2958	12,89	45420	1,5						
	129	2628	11,44	44785	1,7						
	145	2346	10,20	44095	1,8						
	150	2260	9,83	43862	1,9						
	173	1961	8,52	42884	2,1						
	199	1709	7,41	41866	2,3						
		79	4299	18,74	28379	1,0	KR673-3E225S/4C	65,70	552	164	IE3
		89	3800	16,54	32786	1,1	KR673-2E225S/4B	66,00	536		IE2
		156	2173	9,45	40986	1,2					
		178	1913	8,31	40283	1,3					
	45 60	20	19927	48,31	74032	1,0	KR973-3G280S/6	88,00	1600	200	IE3
						KR973-2G280S/6	92,00	1550		IE2	
21		19845	71,60	74107	1,0	KR973-3E225M/4D	80,00	1400	200	IE3	
23		17839	64,28	78554	1,1	KR973-2E225M/4C	80,00	1360		IE2	
27		15212	54,80	83548	1,3						
31		13429	48,31	86601	1,5						
34		11929	42,86	89011	1,6						
39		10648	38,21	90945	1,8						
47		8826	31,63	93467	2,2						
53		7792	27,88	94911	2,5						
60		6922	24,73	95939	2,8						
67		6179	22,05	96816	3,1						
79		5238	18,73	103184	2,4						
89		4624	16,51	102912	2,7						
101		4108	14,65	100091	2,9						
113		3667	13,06	97395	3,2						
126		3286	11,69	94808	3,4						
		27	15394	55,53	76594	1,0	KR873-3E225M/4D	80,00	1002	188	IE3
		30	13806	49,75	84676	1,1	KR873-2E225M/4C	80,00	1002		IE2
		34	11997	43,22	93288	1,2					
		39	10563	38,00	95261	1,3					
		43	9542	34,28	94342	1,4					
		49	8327	29,88	92857	1,6					
		61	6775	24,28	90179	2,1					
		69	5965	21,34	88315	2,3					
		77	5389	19,26	86741	2,4					
		88	4702	16,78	84541	2,7					
		106	3895	13,93	79985	2,2					
		120	3430	12,25	77966	2,4					
		133	3099	11,05	76320	2,6					
		153	2704	9,63	74086	2,9					
		50	8170	29,40	44812	1,0	KR773-3E225M/4D	80,00	728	176	IE3
	56	7384	26,52	45428	1,1	KR773-2E225M/4C	80,00	728		IE2	
	63	6559	23,52	45877	1,2						
	70	5855	20,97	46075	1,4						
	73	5642	20,23	46095	1,4						
	84	4894	17,52	46000	1,5						
	97	4265	15,25	45676	1,7						
	114	3598	12,89	42722	1,3						
	129	3196	11,44	42392	1,4						
	145	2853	10,20	41961	1,5						
	150	2749	9,83	41805	1,5						
	173	2385	8,52	41102	1,7						

*: IE2 ve IE3 motorlu redüktör fiyatları farklıdır. / Geared motor prices are different for IE2 and IE3 motors. / Preise von Getrieben mit IE2 und IE3 Motoren sind unterschiedlich.

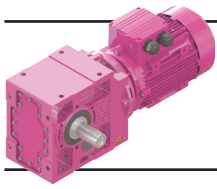

K Serisi Motorlu Güç Devir Sayfaları

K Series Geared Motors Performance Tables

K Serien Getriebemotoren Leistung und Drehzahlübersicht

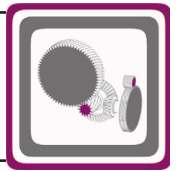

Güç	IE3 Çıkış Devri	IE3 Çıkış Momenti	Çevrim Oranı	IE3 Güv. Rad. Yük Çıkış	IE3 Servis Faktörü	Tipi	Anma Akımı	Ağırlık	Ölçü Sayfası	Motor Verim Snf.*	
Power	Output Speeds	Output Torque	Ratio	Per.O. Loads (Output)	Service Factors	Type	Rated Current	Weight	Dim. Page	Motor Eff. Class	
Leistung P _g [kW] P _g [HP]	Abtriebswelle Drehzahlen n ₂ [r.p.m]	Abtriebswelle Drehmomente M ₂ [Nm]	Übersetzung i	Zul.Querkräfte (Abtrieb) F _{qam} [N]	Betriebsfaktor f _s	Typ	Nennstrom [A]	Gewicht ~ [kg]	Maße Seite	Motor Effizienz-klasse	
45 60	199	2079	7,41	40315	1,9	KR773-3E225M/4D	80,00	728	176	IE3	
						KR773-2E225M/4C	80,00	728		IE2	
	156	2643	9,45	38766	1,0	KR673-3E225M/4D	80,00	587	164	IE3	
	178	2327	8,31	38332	1,1	KR673-2E225M/4C	80,00	587		IE2	
55 75	27	18530	54,80	77344	1,1	KR973-3E250M/4D	95,30	1480	200	IE3	
	31	16358	48,31	81668	1,2	KR973-2E250M/4C	95,50	1420		IE2	
	35	14530	42,86	84989	1,3						
	39	12971	38,21	87602	1,5						
	47	10752	31,63	90971	1,8						
	53	9492	27,88	92810	2,0						
	60	8431	24,73	94179	2,3						
	67	7526	22,05	95219	2,5						
	79	6381	18,73	102370	2,0						
	90	5633	16,51	100587	2,2						
	101	5004	14,65	98030	2,4						
	113	4467	13,06	95560	2,6						
	127	4003	11,69	93167	2,8						
		34	14614	43,22	81836	1,0	KR873-3E250M/4D	95,30	1093	188	IE3
39		12867	38,00	88743	1,1	KR873-2E250M/4C	95,50	1093		IE2	
43		11624	34,28	88461	1,2						
50		10143	29,88	87734	1,3						
61		8252	24,28	86018	1,7						
69		7266	21,34	84657	1,9						
77		6564	19,26	83440	2,0						
88		5728	16,78	81666	2,2						
106		4745	13,93	77275	1,8						
121		4178	12,25	75584	2,0						
134		3775	11,05	74170	2,1						
154		3294	9,63	72213	2,4						
		63	7990	23,52	40661	1,0	KR773-3E250M/4D	95,30	818	176	IE3
		71	7133	20,97	41424	1,1	KR773-2E250M/4C	95,50	818		IE2
	73	6872	20,23	41611	1,1						
	84	5962	17,52	42116	1,3						
	97	5196	15,25	42296	1,4						
	115	4383	12,89	39350	1,0						
	129	3894	11,44	39400	1,1						
	145	3476	10,20	39294	1,2						
	151	3349	9,83	39232	1,3						
	174	2906	8,52	38874	1,4						
	200	2532	7,41	38376	1,5						
	75 97	35	19749	42,86	75105	1,0	KR973-3G280S/4	133,00	1615	200	IE3
		39	17629	38,21	79655	1,1	KR973-2G280S/4	133,00	1585		IE2
		47	14613	31,63	85282	1,3					
53		12901	27,88	88072	1,5						
60		11460	24,73	90248	1,7						
67		10230	22,05	92036	1,9						
79		8673	18,73	97926	1,5						
90		7657	16,51	95915	1,6						
101		6801	14,65	93892	1,8						
114		6071	13,06	91875	1,9						
127		5441	11,69	89873	2,1						

*: IE2 ve IE3 motorlu redüktör fiyatları farklıdır. / Geared motor prices are different for IE2 and IE3 motors. / Preise von Getrieben mit IE2 und IE3 Motoren sind unterschiedlich.

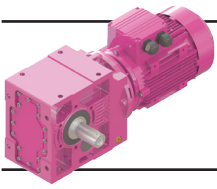

K Serisi Motorlu Güç Devir Sayfaları

K Series Geared Motors Performance Tables

K Serien Getriebemotoren Leistung und Drehzahlübersicht

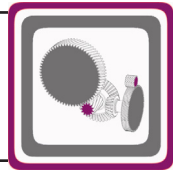

Güç	IE3 Çıkış Devri	IE3 Çıkış Momenti	Çevrim Oranı	IE3 Güv. Rad. Yük Çıkış	IE3 Servis Faktörü	Tipi	Anma Akımı	Ağırlık	Ölçü Sayfası	Motor Verim Snf.*	
Power	Output Speeds	Output Torque	Ratio	Per.O. Loads (Output)	Service Factors	Type	Rated Current	Weight	Dim. Page	Motor Eff. Class	
Leistung P _g [kW] P _g [HP]	Abtriebswelle Drehzahlen n ₂ [r.p.m]	Abtriebswelle Drehmomente M ₂ [Nm]	Übersetzung i	Zul.Querkräfte (Abtrieb) F _{qam} [N]	Betriebsfaktor f _s	Typ	Nennstrom [A]	Gewicht ~ [kg]	Maße Seite	Motor Effizienz- klasse	
75 97	50	13786	29,88	77481	1,0	KR873-3G280S/4	133,00	1280	188	IE3	
	61	11216	24,28	77690	1,3	KR873-2G280S/4	133,00	1280		IE2	
	70	9876	21,34	77337	1,4						
	77	8922	19,26	76837	1,5						
	88	7785	16,78	75912	1,6						
	107	6450	13,93	71851	1,3						
	121	5679	12,25	70816	1,5						
	134	5130	11,05	69869	1,6						
	154	4477	9,63	68466	1,8						
90 117	47	17536	31,63	80119	1,1	KR973-3G280M/4	158,00	1675	200	IE3	
	53	15481	27,88	83948	1,2	KR973-2G280M/4	158,00	1625		IE2	
	60	13752	24,73	86873	1,4						
	67	12276	22,05	89224	1,6						
	79	10408	18,73	93920	1,2						
	90	9188	16,51	92391	1,3						
	101	8162	14,65	90773	1,5						
	114	7286	13,06	89099	1,6						
	127	6530	11,69	87392	1,7						
		61	13460	24,28	71440	1,0	KR873-3G280M/4	158,00	1350	188	IE3
		70	11852	21,34	71843	1,1	KR873-2G280M/4	158,00	1350		IE2
		77	10707	19,26	71881	1,2					
		88	9343	16,78	71594	1,3					
		107	7740	13,93	67780	1,1					
		121	6815	12,25	67238	1,2					
		134	6157	11,05	66642	1,3					
		154	5373	9,63	65653	1,5					
	110 148	53	18897	27,88	77626	1,0	KR973-3G315S/4	194,00	1870	200	IE3
60		16786	24,73	81717	1,1	KR973-2G315S/4	195,00	1800		IE2	
67		14985	22,05	85041	1,3						
79		12704	18,73	88546	1,0						
90		11216	16,51	87668	1,1						
102		9963	14,65	86593	1,2						
114		8894	13,06	85380	1,3						
127		7970	11,69	84069	1,4						
132 177	60	20144	24,73	75130	1,0	KR973-3G315M/4a	230,00	1890	200	IE3	
	67	17982	22,05	79729	1,1	KR973-2G315M/4a	230,00	1820		IE2	
	102	11956	14,65	81968	1,0						
	114	10673	13,06	81267	1,1						
	127	9565	11,69	80396	1,2						
160 215	127	11587	11,69	75692	1,0	KR973-3G315M/4b	280,00	1940	200	IE3	
						KR973-2G315M/4b	275,00	1900		IE2	

*: IE2 ve IE3 motorlu redüktör fiyatları farklıdır. / Geared motor prices are different for IE2 and IE3 motors. / Preise von Getrieben mit IE2 und IE3 Motoren sind unterschiedlich.

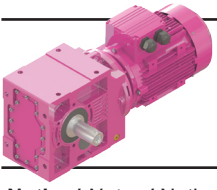

K Serisi Motorlu Güç Devir Sayfaları
K Series Geared Motors Performance Tables
K Serien Getriebemotoren Leistung und Drehzahlübersicht

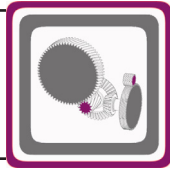

Notlar / Notes / Notizen

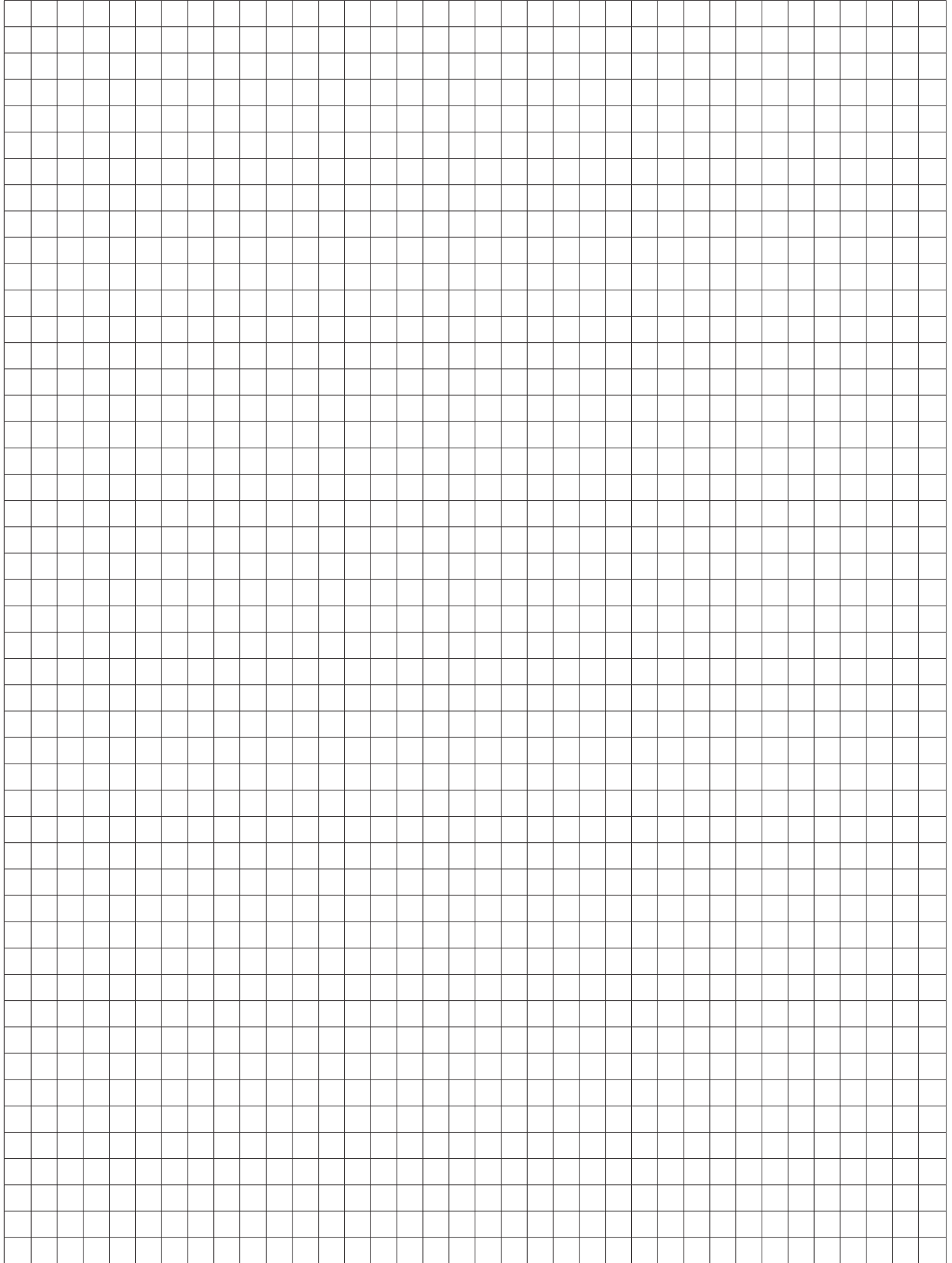

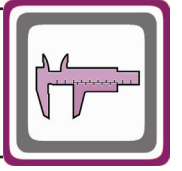
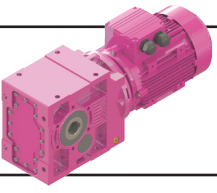

Ölçü Sayfaları

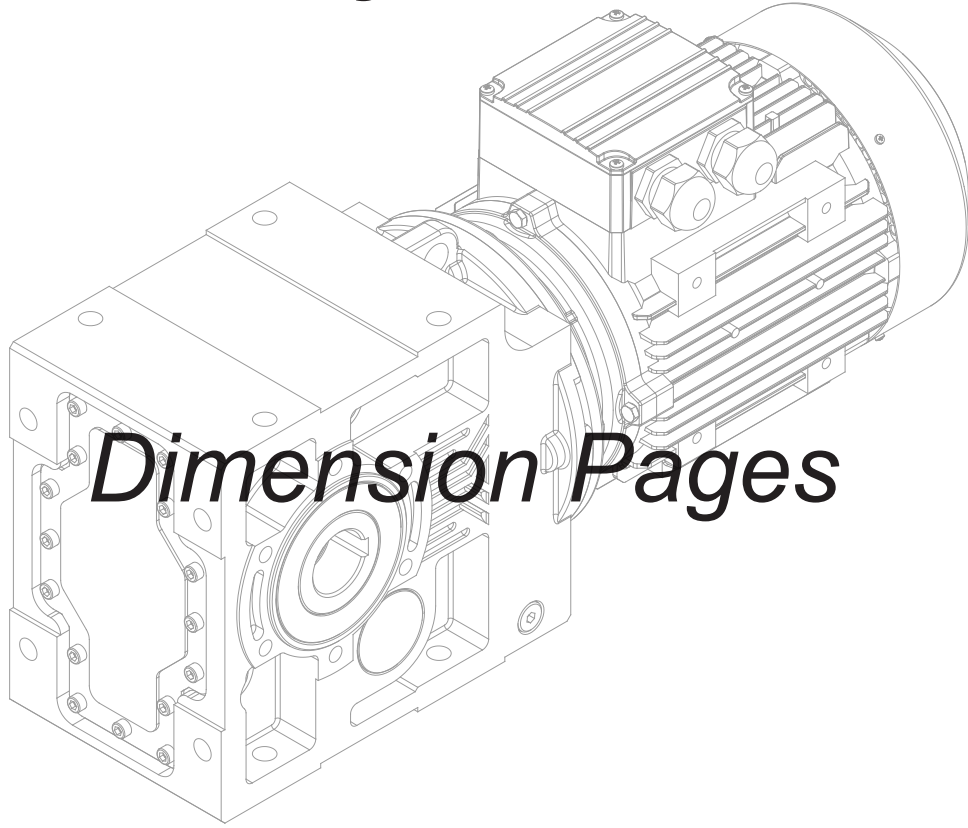

Dimension Pages

Abmessungenseiten

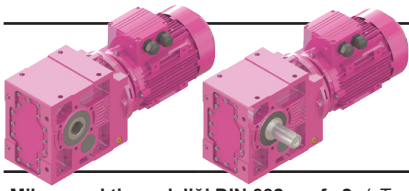

Ölçü Sayfaları

Dimension Pages

Abmessungsseiten

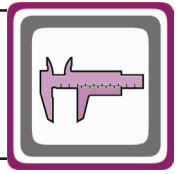

-Mil ucu çekirme deliği DIN 332 sayfa 2 / Tapped center hole to DIN 332, sheet 2 / Zentrierung mit Gewinde DIN 332, Blatt 2

KR002.00
KR003.00

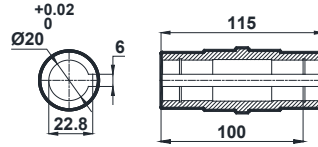
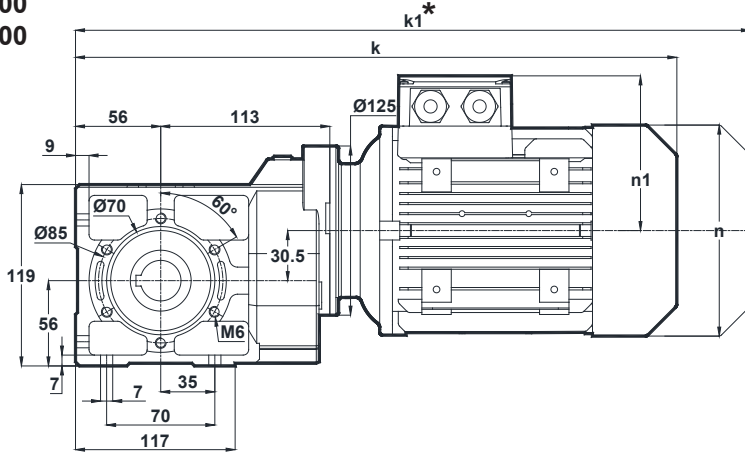

	63	71	80	90S	90L
k	366.5	395	429	468	468
k1	427.5	486	522	571.5	571.5
n	121	137	155	176	176
n1	97	112	123	132	132

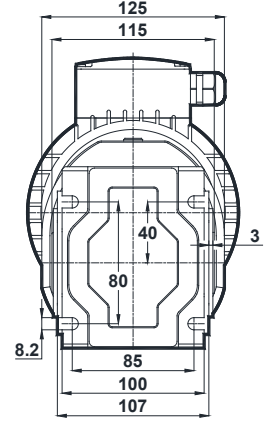

Klemens Pozisyonları
Terminal Box Positions
Klemmenkasten Positionen

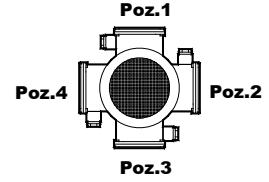

63-71-80-90
Tip / Type / Typ

KR002.01
KR003.01

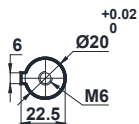
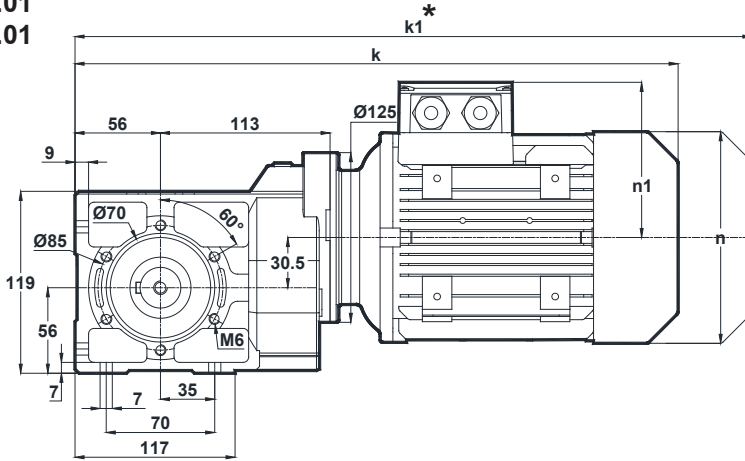

	63	71	80	90S	90L
k	366.5	395	429	468	468
k1	427.5	486	522	571.5	571.5
n	121	137	155	176	176
n1	97	112	123	132	132

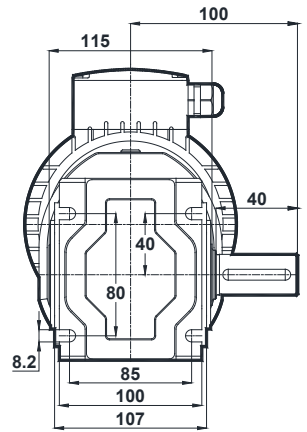

* "k1" Ölçüsü frenli redüktörlere aittir.
Dimension "k1" is for motors with brake.
Maße "k1" ist für Bremsenmotoren.

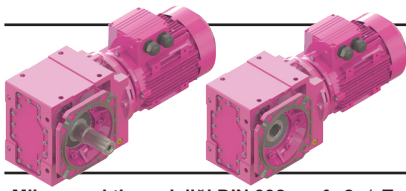

Ölçü Sayfaları

Dimension Pages

Abmessungsseiten

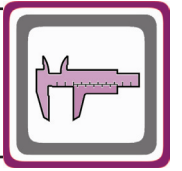

-Mil ucu çektirme deliği DIN 332 sayfa 2 / Tapped center hole to DIN 332, sheet 2 / Zentrierung mit Gewinde DIN 332, Blatt 2

KR002.02
KR003.02

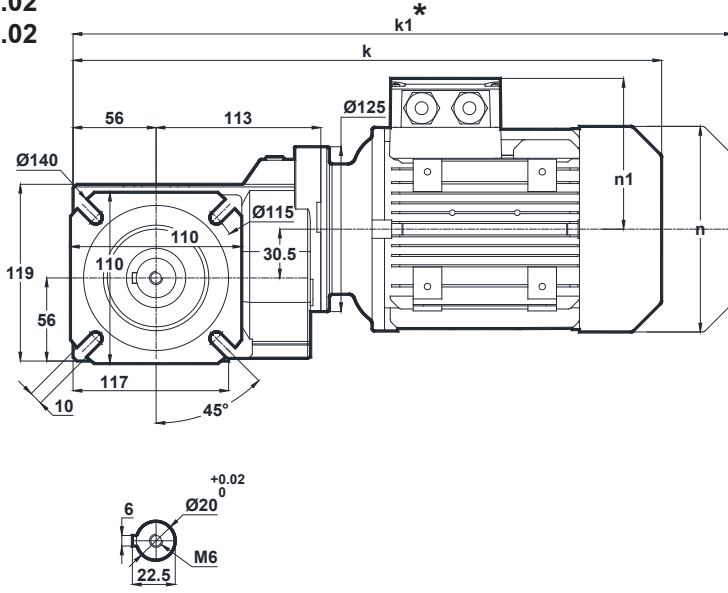

	63	71	80	90S	90L
k	366.5	395	429	468	468
k1	427.5	486	522	571.5	571.5
n	121	137	155	176	176
n1	97	112	123	132	132

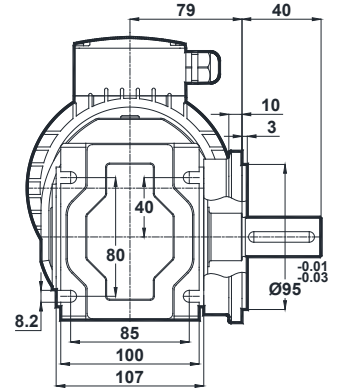

Klemens Pozisyonları
Terminal Box Positions
Klemmenkasten Positionen

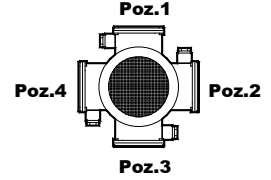

63-71-80-90
Tip / Type / Typ

Opsiyonel flanş ölçüleri için sayfa 587'ye bakınız.
Please see on page 587 for optional flange dimensions
Siehe Seite 587 für auswählbare Flanschabmessungen

KR002.03
KR003.03

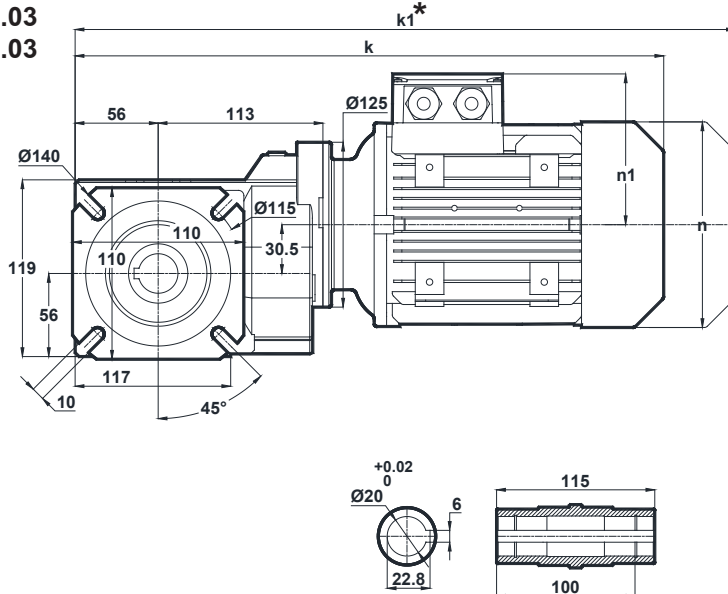

	63	71	80	90S	90L
k	366.5	395	429	468	468
k1	427.5	486	522	571.5	571.5
n	121	137	155	176	176
n1	97	112	123	132	132

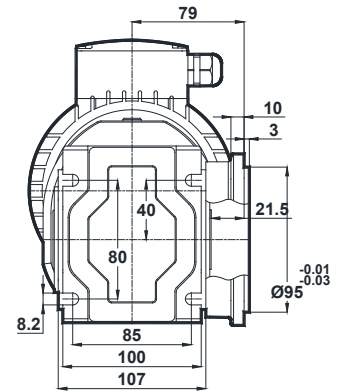

Opsiyonel flanş ölçüleri için sayfa 587'ye bakınız.
Please see on page 587 for optional flange dimensions
Siehe Seite 587 für auswählbare Flanschabmessungen

* "k1" Ölçüsü frenli redüktörlere aittir.
Dimension "k1" is for motors with brake.
Maße "k1" ist für Bremsenmotoren.

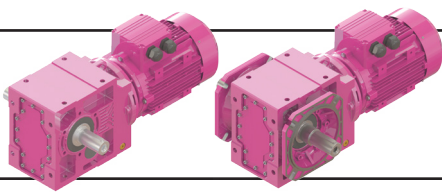

Ölçü Sayfaları

Dimension Pages

Abmessungsseiten

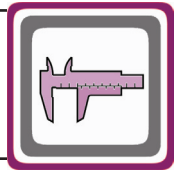

-Mil ucu çektirme deliği DIN 332 sayfa 2 / Tapped center hole to DIN 332, sheet 2 / Zentrierung mit Gewinde DIN 332, Blatt 2

KR002.04
KR003.04

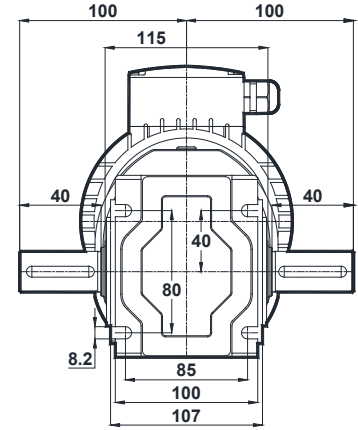
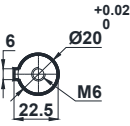
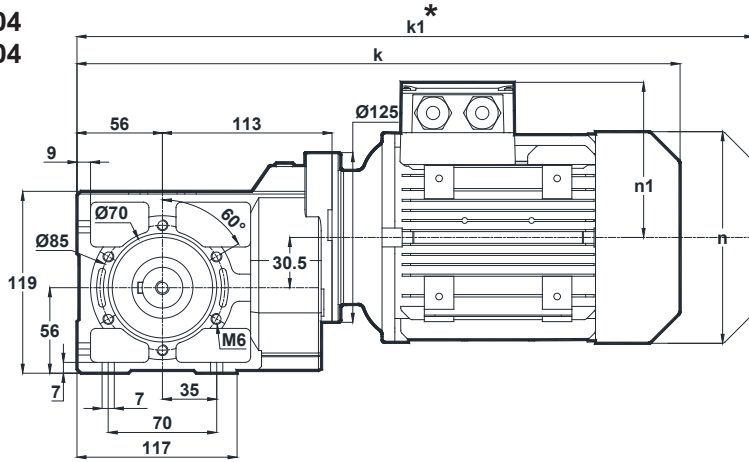

Klemens Pozisyonları
Terminal Box Positions
Klemmenkasten Positionen

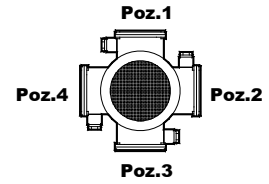

63-71-80-90
Tip / Type / Typ

	63	71	80	90S	90L
k	366.5	395	429	468	468
k1	427.5	486	522	571.5	571.5
n	121	137	155	176	176
n1	97	112	123	132	132

KR002.05
KR003.05

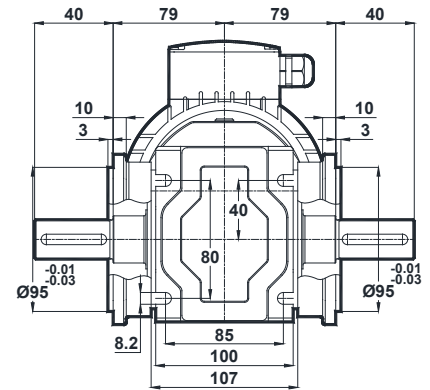
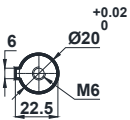
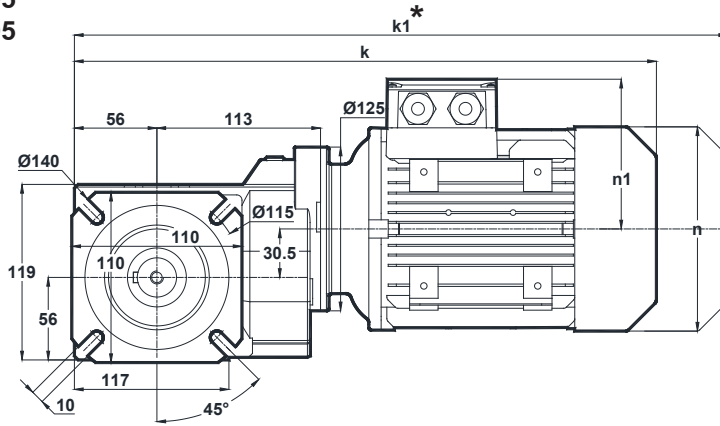

	63	71	80	90S	90L
k	366.5	395	429	468	468
k1	427.5	486	522	571.5	571.5
n	121	137	155	176	176
n1	97	112	123	132	132

Opsiyonel flanş ölçüleri için sayfa 587'ye bakınız.
Please see on page 587 for optional flange dimensions
Siehe Seite 587 für auswählbare Flanschabmessungen

* "k1" Ölçüsü frenli redüktörlere aittir.
Dimension "k1" is for motors with brake.
Maße "k1" ist für Bremsenmotoren.

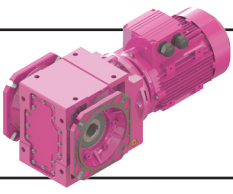

Ölçü Sayfaları Dimension Pages Abmessungsseiten

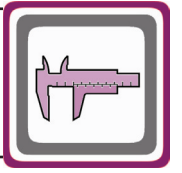

-Mil ucu çektirme deliği DIN 332 sayfa 2 / Tapped center hole to DIN 332, sheet 2 / Zentrierung mit Gewinde DIN 332, Blatt 2

KR002.08
KR003.08

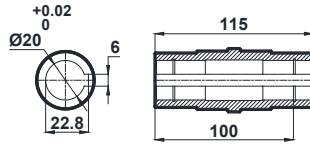
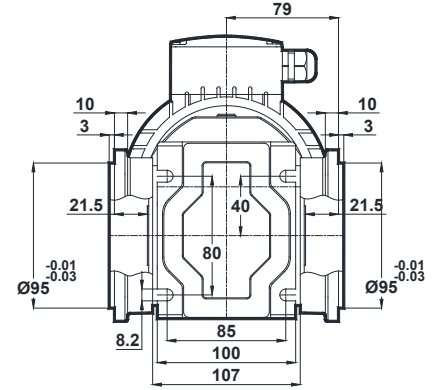
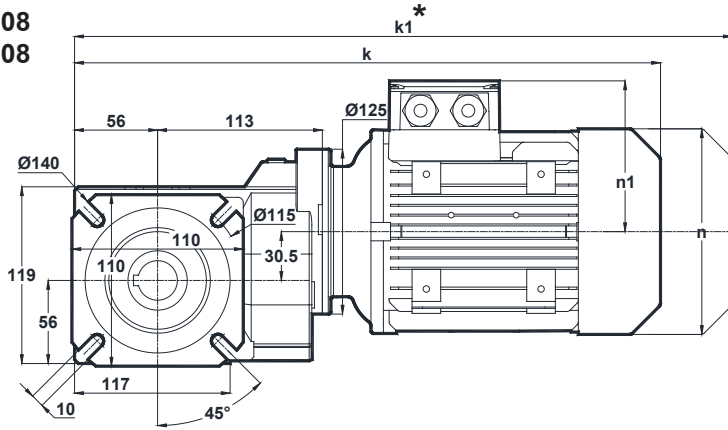

Klemens Pozisyonları
Terminal Box Positions
Klemmenkasten Positionen

	63	71	80	90S	90L
k	366.5	395	429	468	468
k1	427.5	486	522	571.5	571.5
n	121	137	155	176	176
n1	97	112	123	132	132

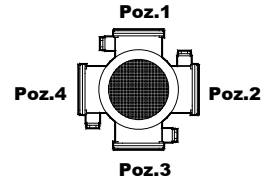

63-71-80-90
Tip / Type / Typ

Opsiyonel flanş ölçüleri için sayfa 587'ye bakınız.
Please see on page 587 for optional flange dimensions
Siehe Seite 587 für auswählbare Flanschabmessungen

* "k1" Ölçüsü frenli redüktörlere aittir.
Dimension "k1" is for motors with brake.
Maße "k1" ist für Bremsenmotoren.

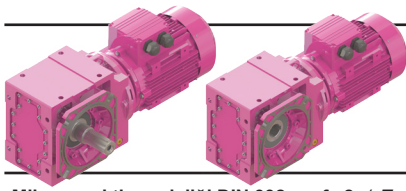

Ölçü Sayfaları

Dimension Pages

Abmessungsseiten

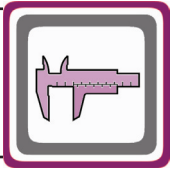

-Mil ucu çektirme deliği DIN 332 sayfa 2 / Tapped center hole to DIN 332, sheet 2 / Zentrierung mit Gewinde DIN 332, Blatt 2

KR102.02
KR103.02

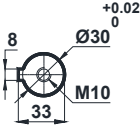
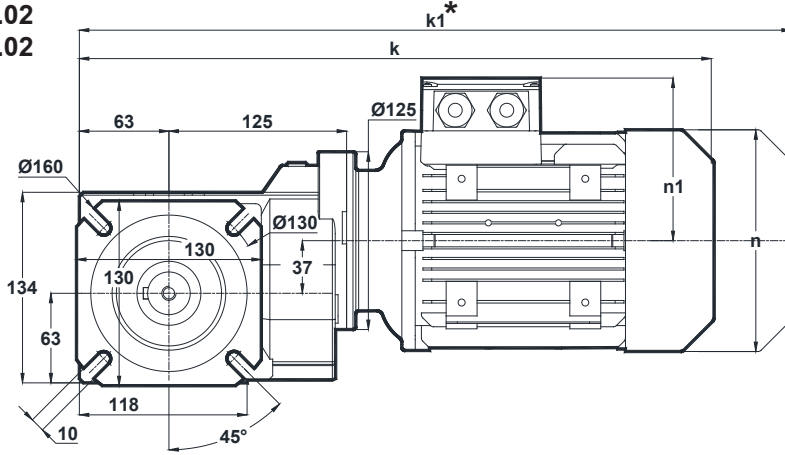

	63	71	80	90S	90L
k	385.5	414	448	487	487
k1	446.5	505	541	590.5	590.5
n	121	137	155	176	176
n1	97	112	123	132	132

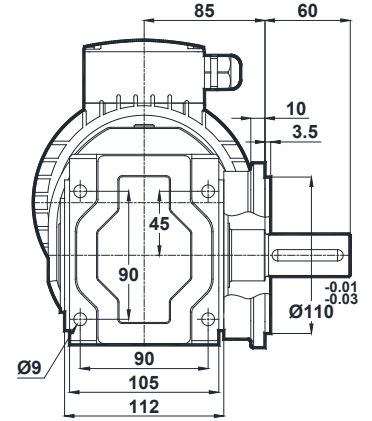

Klemens Pozisyonları
Terminal Box Positions
Klemmenkasten Positionen

Poz.1

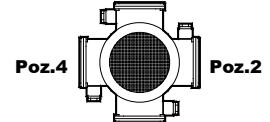

Poz.3

63-71-80-90
Tip / Type / Typ

Opsiyonel flanş ölçüleri için sayfa 587'ye bakınız.
Please see on page 587 for optional flange dimensions
Siehe Seite 587 für auswählbare Flanschabmessungen

KR102.03
KR103.03

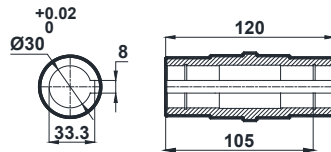
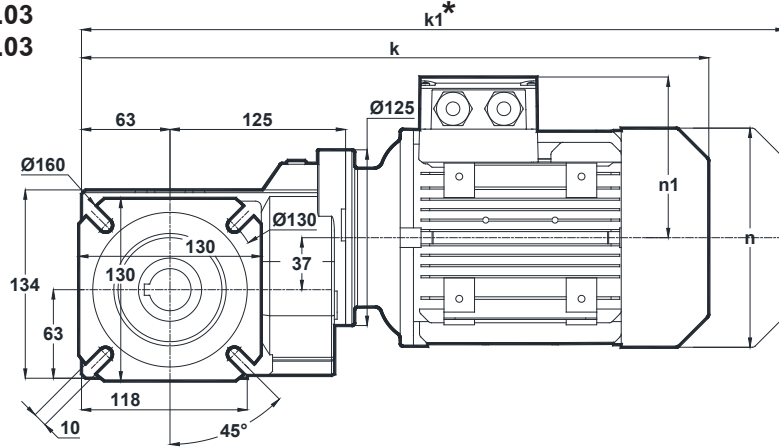

	63	71	80	90S	90L
k	385.5	414	448	487	487
k1	446.5	505	541	590.5	590.5
n	121	137	155	176	176
n1	97	112	123	132	132

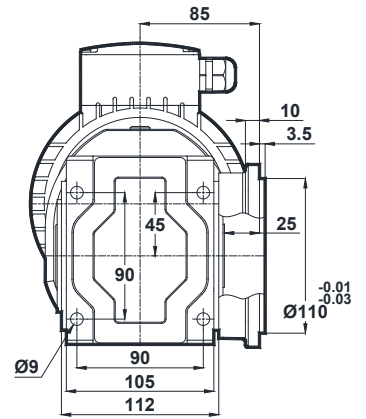

Opsiyonel flanş ölçüleri için sayfa 587'ye bakınız.
Please see on page 587 for optional flange dimensions
Siehe Seite 587 für auswählbare Flanschabmessungen

* " k1 " Ölçüsü frenli redüktörlere aittir.
Dimension " k1 " is for motors with brake.
Maße " k1 " ist für Bremsenmotoren.

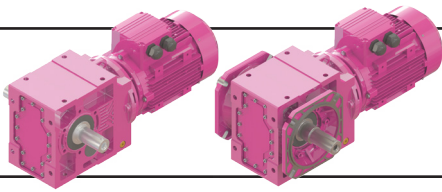

Ölçü Sayfaları

Dimension Pages

Abmessungsseiten

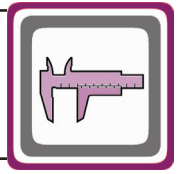

-Mil ucu çektirme deliği DIN 332 sayfa 2 / Tapped center hole to DIN 332, sheet 2 / Zentrierung mit Gewinde DIN 332, Blatt 2

KR102.04
KR103.04

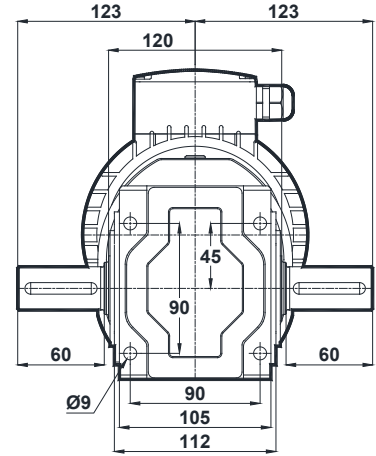
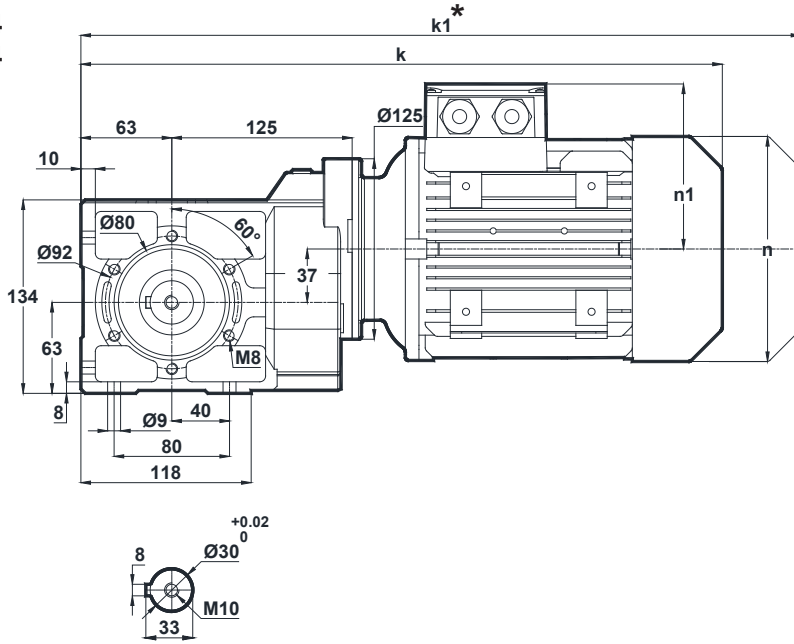

Klemens Pozisyonları
Terminal Box Positions
Klemmenkasten Positionen

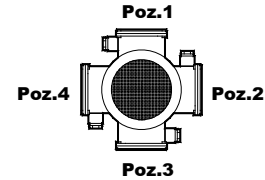

63-71-80-90
Tip / Type / Typ

	63	71	80	90S	90L
k	385.5	414	448	487	487
k1	446.5	505	541	590.5	590.5
n	121	137	155	176	176
n1	97	112	123	132	132

KR102.05
KR103.05

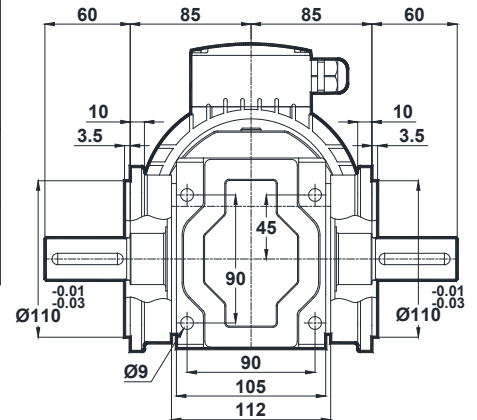
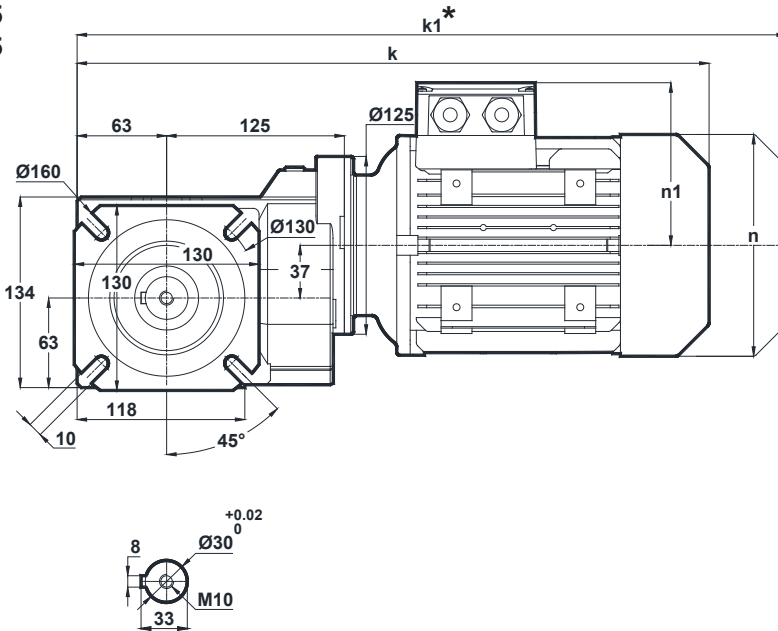

	63	71	80	90S	90L
k	385.5	414	448	487	487
k1	446.5	505	541	590.5	590.5
n	121	137	155	176	176
n1	97	112	123	132	132

Opsiyonel flanş ölçüleri için sayfa 587'ye bakınız.
Please see on page 587 for optional flange dimensions
Siehe Seite 587 für auswählbare Flanschabmessungen

* "k1" Ölçüsü frenli redüktörlere aittir.
Dimension "k1" is for motors with brake.
Maße "k1" ist für Bremsenmotoren.

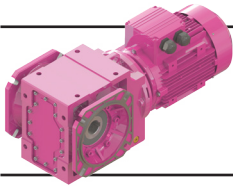

Ölçü Sayfaları Dimension Pages Abmessungsseiten

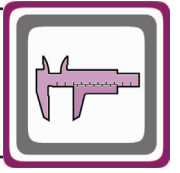

-Mil ucu çektirme deliği DIN 332 sayfa 2 / Tapped center hole to DIN 332, sheet 2 / Zentrierung mit Gewinde DIN 332, Blatt 2

KR102.08
KR103.08

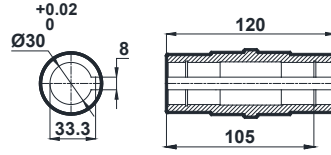
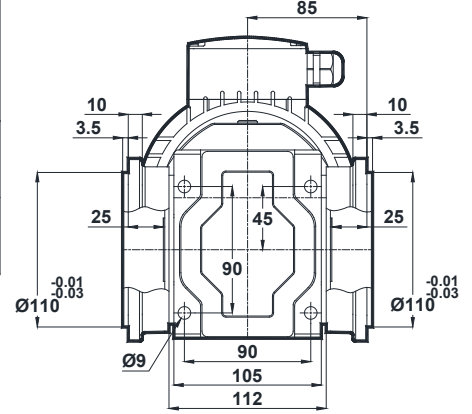
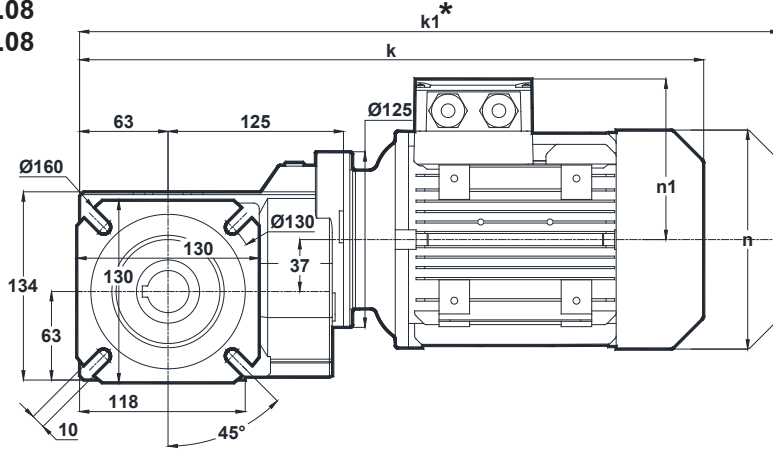

	63	71	80	90S	90L
k	385.5	414	448	487	487
k1	446.5	505	541	590.5	590.5
n	121	137	155	176	176
n1	97	112	123	132	132

Klemens Pozisyonları
Terminal Box Positions
Klemmenkasten Positionen

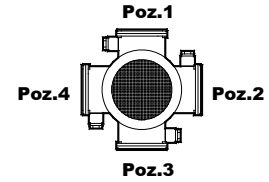

63-71-80-90
Tip / Type / Typ

Opsiyonel flanş ölçüleri için sayfa 587'ye bakınız.
Please see on page 587 for optional flange dimensions
Siehe Seite 587 für auswählbare Flanschabmessungen

* "k1" Ölçüsü frenli redüktörlere aittir.
Dimension "k1" is for motors with brake.
Maße "k1" ist für Bremsenmotoren.

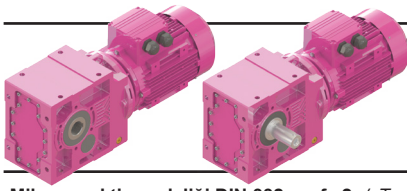

Ölçü Sayfaları

Dimension Pages

Abmessungsseiten

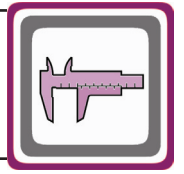

-Mil ucu çektirme deliği DIN 332 sayfa 2 / Tapped center hole to DIN 332, sheet 2 / Zentrierung mit Gewinde DIN 332, Blatt 2

KR202.00
KR203.00

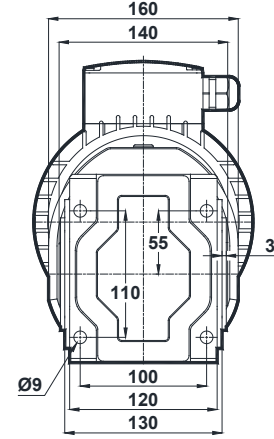
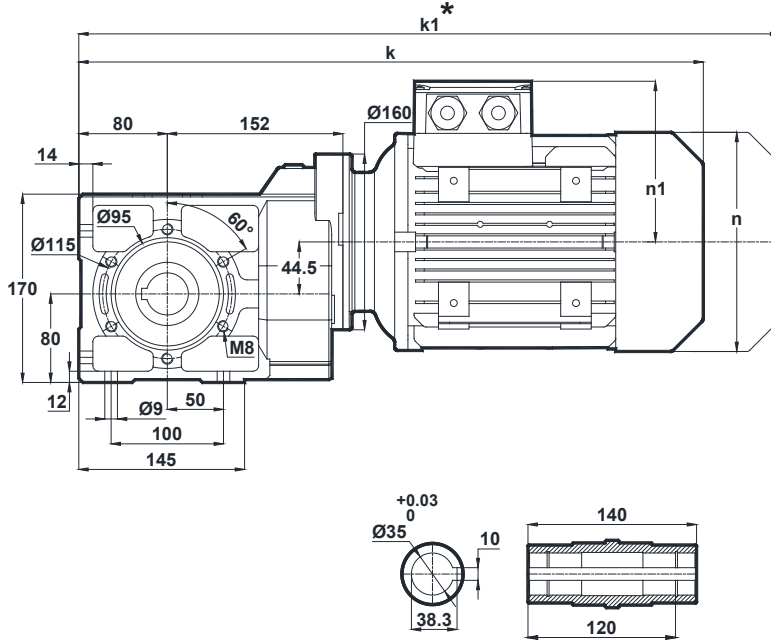

Klemens Pozisyonları
Terminal Box Positions
Klemmenkasten Positionen

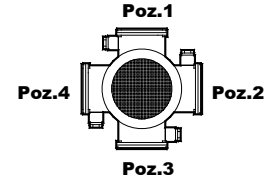

63-71-80-90-100-112
Tip / Type / Typ

	63	71	80	90S	90L	100L	112M
k	426	453	487	526	526	574	598
k1	487	544	580	629.5	629.5	682.5	702.5
n	121	137	155	176	176	193	215
n1	97	112	123	132	132	149	161

KR202.01
KR203.01

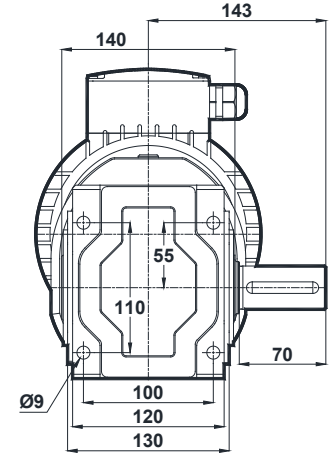
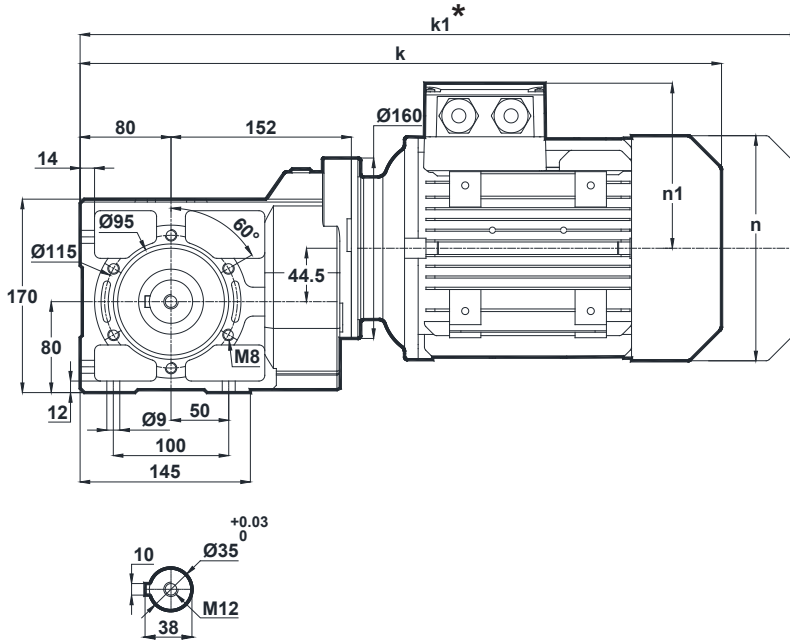

	63	71	80	90S	90L	100L	112M
k	426	453	487	526	526	574	598
k1	487	544	580	629.5	629.5	682.5	702.5
n	121	137	155	176	176	193	215
n1	97	112	123	132	132	149	161

* "k1" Ölçüsü frenli redüktörlere aittir.
Dimension "k1" is for motors with brake.
Maße "k1" ist für Bremsenmotoren.

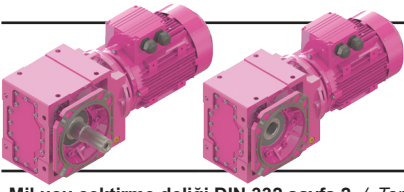

Ölçü Sayfaları

Dimension Pages

Abmessungsseiten

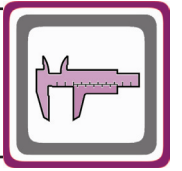

-Mil ucu çektirme deliği DIN 332 sayfa 2 / Tapped center hole to DIN 332, sheet 2 / Zentrierung mit Gewinde DIN 332, Blatt 2

KR202.02
KR203.02

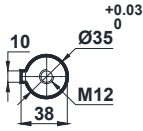
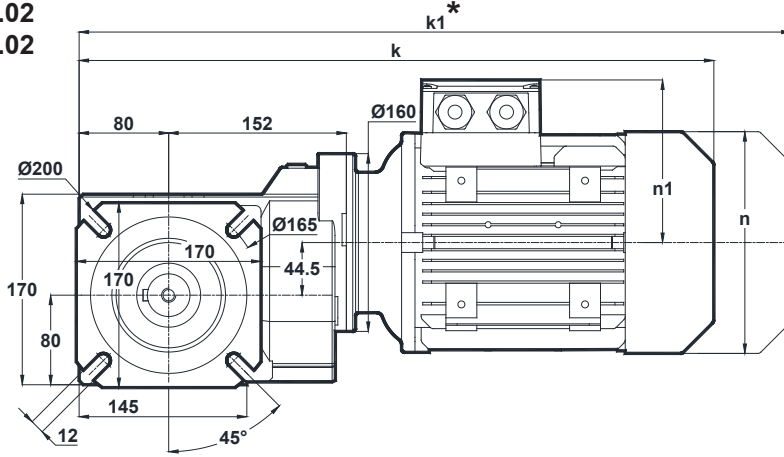

	63	71	80	90S	90L	100L	112M
k	426	453	487	526	526	574	598
k1	487	544	580	629.5	629.5	682.5	702.5
n	121	137	155	176	176	193	215
n1	97	112	123	132	132	149	161

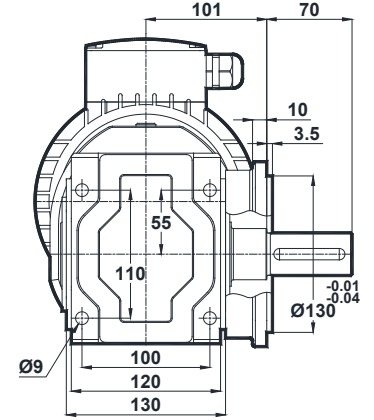

Klemens Pozisyonları
Terminal Box Positions
Klemmenkasten Positionen

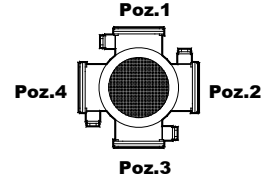

63-71-80-90-100-112
Tip / Type / Typ

Opsiyonel flanş ölçüleri için sayfa 587'ye bakınız.
Please see on page 587 for optional flange dimensions
Siehe Seite 587 für auswählbare Flanschabmessungen

KR202.03
KR203.03

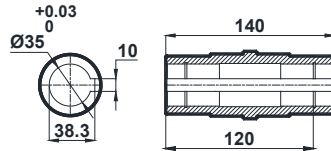
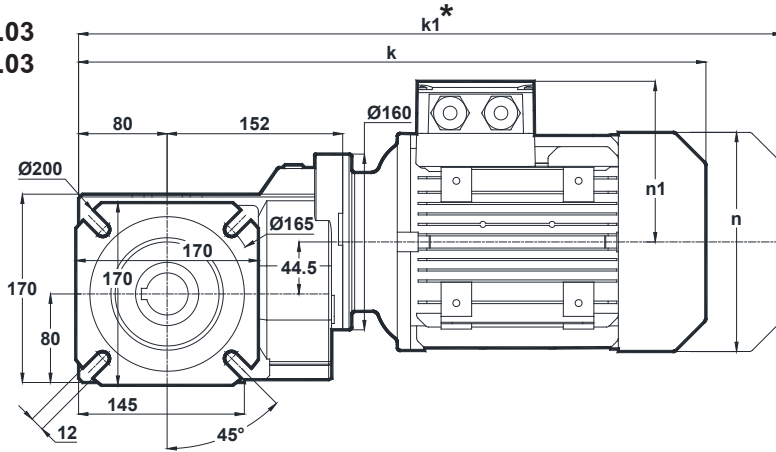

	63	71	80	90S	90L	100L	112M
k	426	453	487	526	526	574	598
k1	487	544	580	629.5	629.5	682.5	702.5
n	121	137	155	176	176	193	215
n1	97	112	123	132	132	149	161

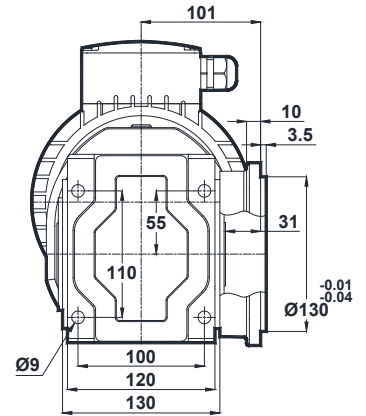

Opsiyonel flanş ölçüleri için sayfa 587'ye bakınız.
Please see on page 587 for optional flange dimensions
Siehe Seite 587 für auswählbare Flanschabmessungen

* "k1" Ölçüsü frenli redüktörlere aittir.
Dimension "k1" is for motors with brake.
Maße "k1" ist für Bremsenmotoren.

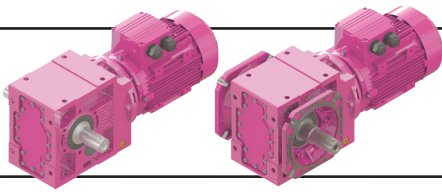

Ölçü Sayfaları

Dimension Pages

Abmessungsseiten

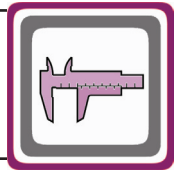

-Mil ucu çektirme deliği DIN 332 sayfa 2 / Tapped center hole to DIN 332, sheet 2 / Zentrierung mit Gewinde DIN 332, Blatt 2

KR202.04
KR203.04

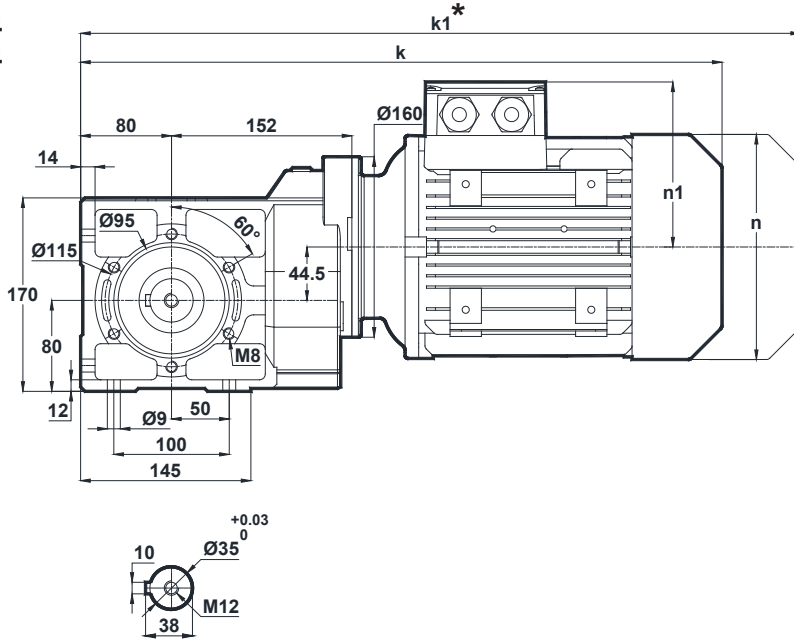

	63	71	80	90S	90L	100L	112M
k	426	453	487	526	526	574	598
k1	487	544	580	629.5	629.5	682.5	702.5
n	121	137	155	176	176	193	215
n1	97	112	123	132	132	149	161

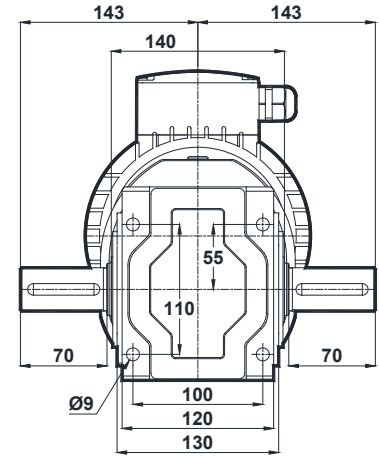

Klemens Pozisyonları
Terminal Box Positions
Klemmenkasten Positionen

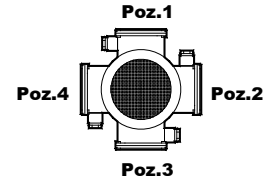

63-71-80-90-100-112
Tip / Type / Typ

KR202.05
KR203.05

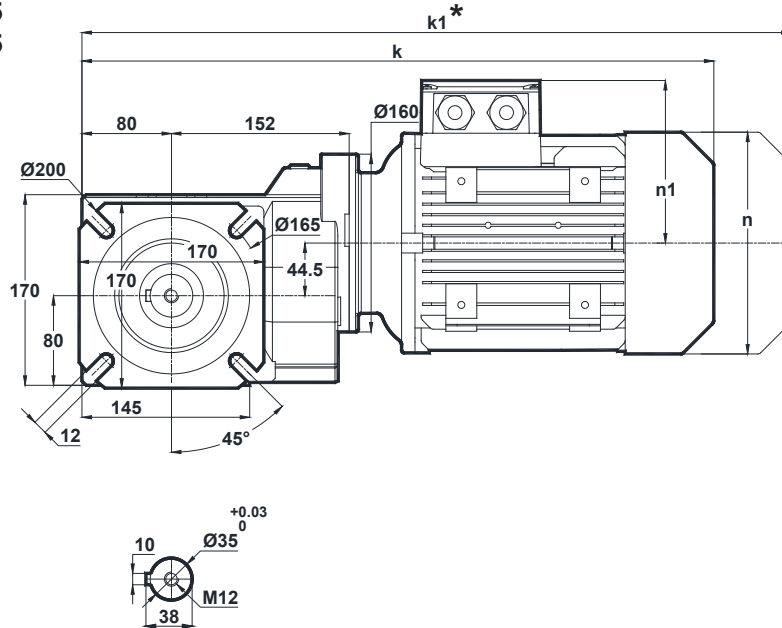

	63	71	80	90S	90L	100L	112M
k	426	453	487	526	526	574	598
k1	487	544	580	629.5	629.5	682.5	702.5
n	121	137	155	176	176	193	215
n1	97	112	123	132	132	149	161

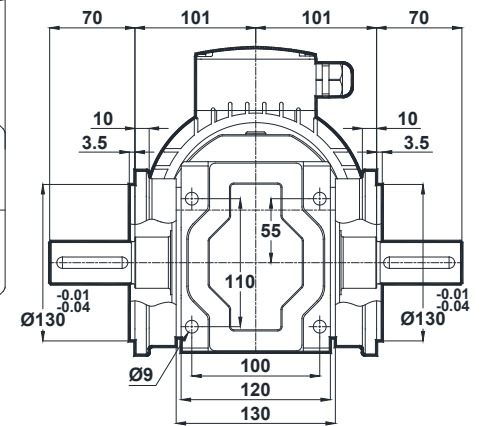

Opsiyonel flanş ölçüleri için sayfa 587'ye bakınız.
Please see on page 587 for optional flange dimensions
Siehe Seite 587 für auswählbare Flanschabmessungen

* "k1" Ölçüsü frenli redüktörlere aittir.
Dimension "k1" is for motors with brake.
Maße "k1" ist für Bremsenmotoren.

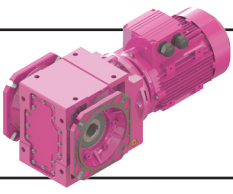

Ölçü Sayfaları Dimension Pages Abmessungsseiten

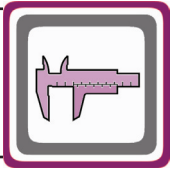

-Mil ucu çektirme deliği DIN 332 sayfa 2 / Tapped center hole to DIN 332, sheet 2 / Zentrierung mit Gewinde DIN 332, Blatt 2

KR202.08
KR203.08

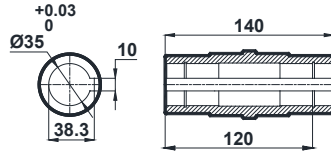
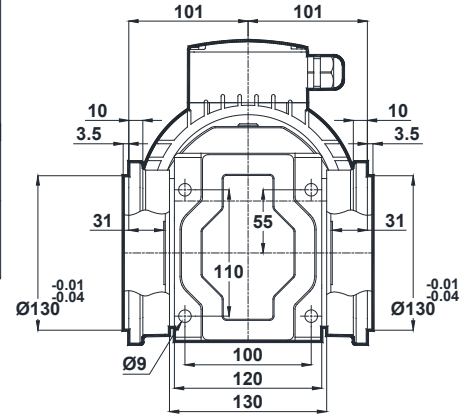
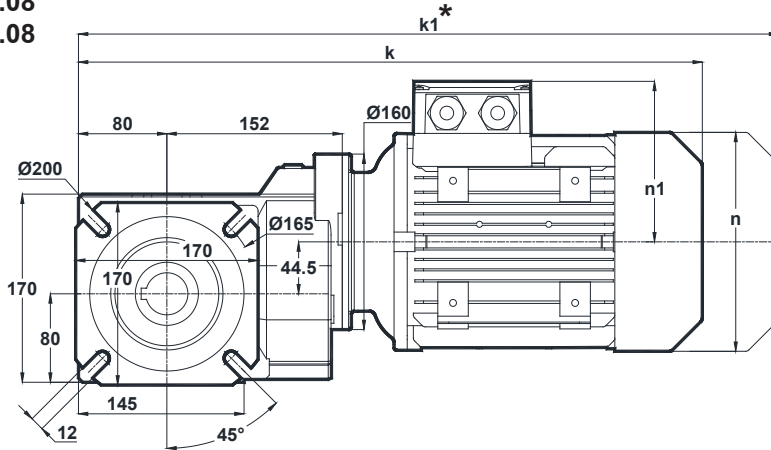

Klemens Pozisyonları
Terminal Box Positions
Klemmenkasten Positionen

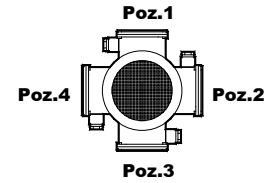

63-71-80-90-100-112
Tip / Type / Typ

	63	71	80	90S	90L	100L	112M
k	426	453	487	526	526	574	598
k1	487	544	580	629.5	629.5	682.5	702.5
n	121	137	155	176	176	193	215
n1	97	112	123	132	132	149	161

Opsiyonel flanş ölçüleri için sayfa 587'ye bakınız.
Please see on page 587 for optional flange dimensions
Siehe Seite 587 für auswählbare Flanschabmessungen

* "k1" Ölçüsü frenli redüktörlere aittir.
Dimension "k1" is for motors with brake.
Maße "k1" ist für Bremsenmotoren.

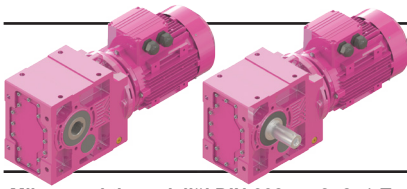

Ölçü Sayfaları

Dimension Pages

Abmessungsseiten

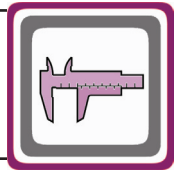

-Mil ucu çektirme deliği DIN 332 sayfa 2 / Tapped center hole to DIN 332, sheet 2 / Zentrierung mit Gewinde DIN 332, Blatt 2

KR273.00

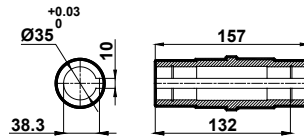
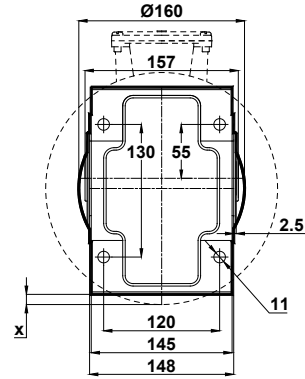
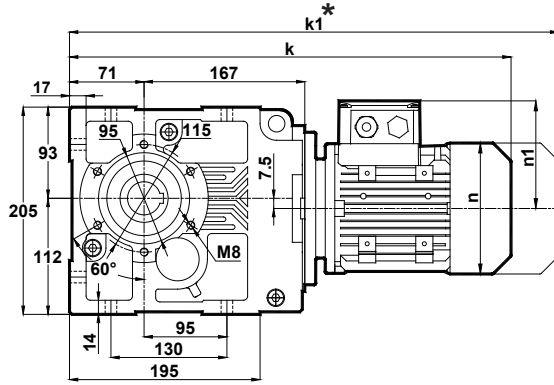

x: Motor Ayak bağlantı yüzeyinin altında ise
x: If Motor is lower than foot mounting plane
x: Wenn der Motor unter der Fußmontageebene ist

Klemens Pozisyonları
Terminal Box Positions
Klemmenkasten Positionen

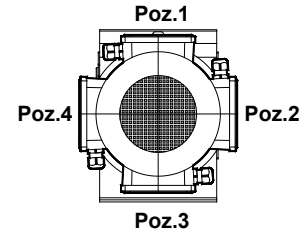

63-71-80-90-100-112
Tip / Type / Typ

	63	71	80	90S	90L	100L	112M
k	432	459	493	532	532	580	604
k1	493	550	586	635.5	635.5	688.5	708.5
n	121	137	155	176	176	193	215
n1	97	112	123	132	132	149	161
x	-	-	-	-	-	-	3

KR273.01

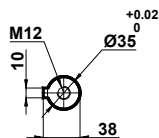
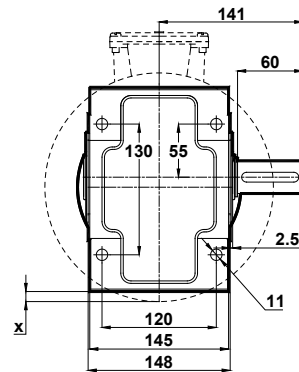
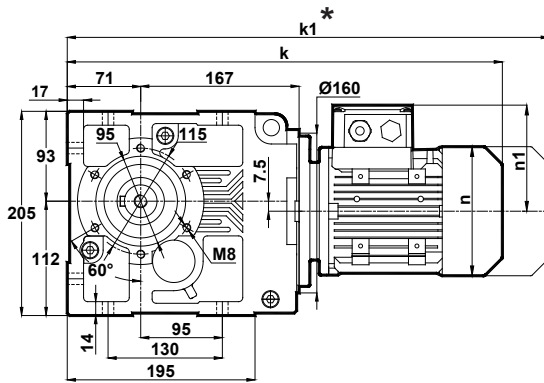

x: Motor Ayak bağlantı yüzeyinin altında ise
x: If Motor is lower than foot mounting plane
x: Wenn der Motor unter der Fußmontageebene ist

	63	71	80	90S	90L	100L	112M
k	432	459	493	532	532	580	604
k1	493	550	586	635.5	635.5	688.5	708.5
n	121	137	155	176	176	193	215
n1	97	112	123	132	132	149	161
x	-	-	-	-	-	-	3

* "k1" Ölçüsü frenli redüktörlere aittir.
Dimension "k1" is for motors with brake.
Maße "k1" ist für Bremsenmotoren.

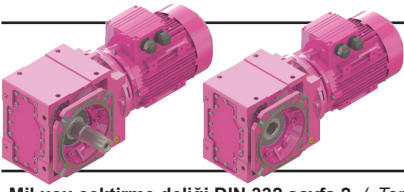

Ölçü Sayfaları Dimension Pages Abmessungsseiten

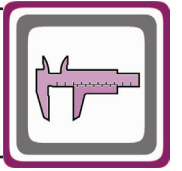

-Mil ucu çektirme deliği DIN 332 sayfa 2 / Tapped center hole to DIN 332, sheet 2 / Zentrierung mit Gewinde DIN 332, Blatt 2

KR273.02

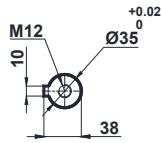
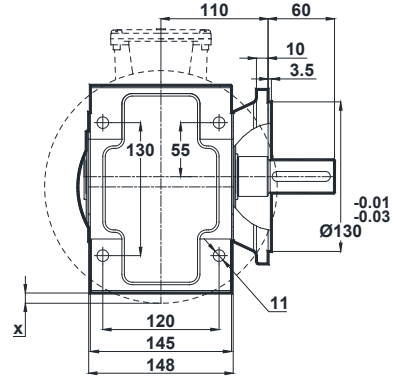
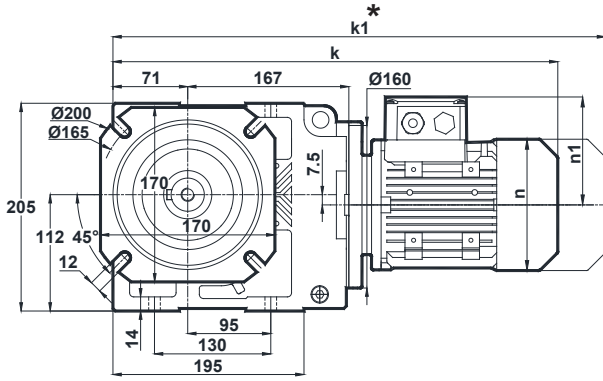

x: Motor Ayak bağlantı yüzeyinin altında ise
x: If Motor is lower than foot mounting plane
x: Wenn der Motor unter der Fußmontageebene ist

Klemens Pozisyonları
Terminal Box Positions
Klemmenkasten Positionen

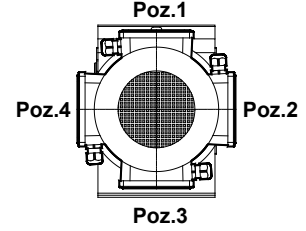

63-71-80-90-100-112
Tip / Type / Typ

Opsiyonel flanş ölçüleri için sayfa 587'ye bakınız.
Please see on page 587 for optional flange dimensions
Siehe Seite 587 für auswählbare Flanschabmessungen

	63	71	80	90S	90L	100L	112M
k	432	459	493	532	532	580	604
k1	493	550	586	635.5	635.5	688.5	708.5
n	121	137	155	176	176	193	215
n1	97	112	123	132	132	149	161
x	-	-	-	-	-	-	3

KR273.03

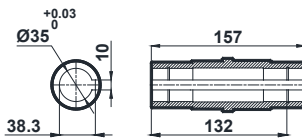
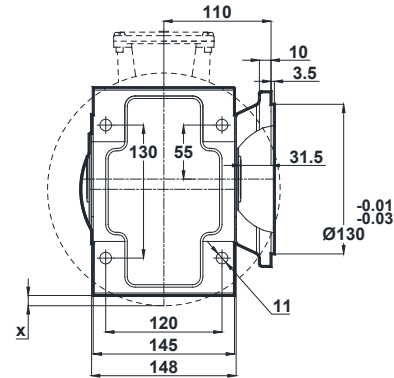
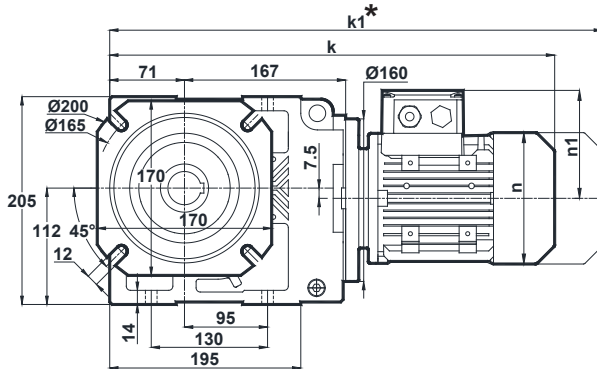

x: Motor Ayak bağlantı yüzeyinin altında ise
x: If Motor is lower than foot mounting plane
x: Wenn der Motor unter der Fußmontageebene ist

	63	71	80	90S	90L	100L	112M
k	432	459	493	532	532	580	604
k1	493	550	586	635.5	635.5	688.5	708.5
n	121	137	155	176	176	193	215
n1	97	112	123	132	132	149	161
x	-	-	-	-	-	-	3

Opsiyonel flanş ölçüleri için sayfa 587'ye bakınız.
Please see on page 587 for optional flange dimensions
Siehe Seite 587 für auswählbare Flanschabmessungen

* "k1" Ölçüsü frenli redüktörlere aittir.
Dimension "k1" is for motors with brake.
Maße "k1" ist für Bremsenmotoren.

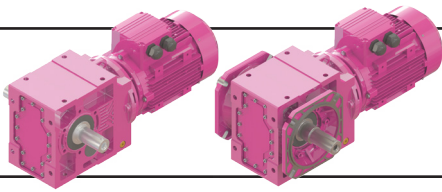

Ölçü Sayfaları

Dimension Pages

Abmessungsseiten

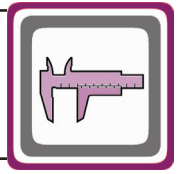

-Mil ucu çektirme deliği DIN 332 sayfa 2 / Tapped center hole to DIN 332, sheet 2 / Zentrierung mit Gewinde DIN 332, Blatt 2

KR273.04

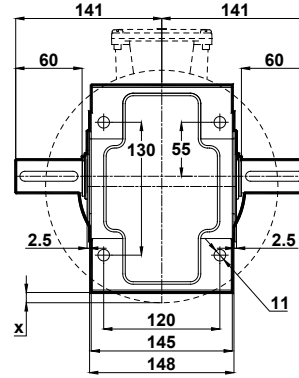
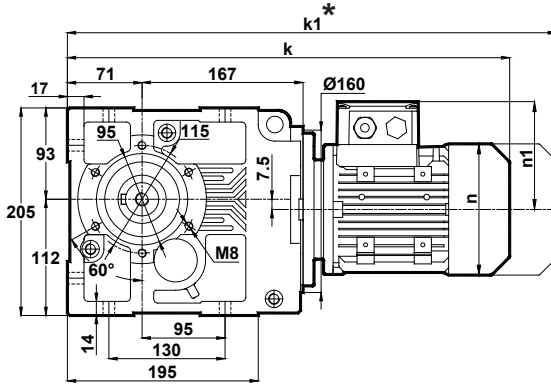

x: Motor Ayak bağlantı yüzeyinin altında ise
 x: If Motor is lower than foot mounting plane
 x: Wenn der Motor unter der Fußmontageebene ist

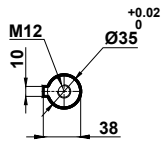

	63	71	80	90S	90L	100L	112M
k	432	459	493	532	532	580	604
k1	493	550	586	635.5	635.5	688.5	708.5
n	121	137	155	176	176	193	215
n1	97	112	123	132	132	149	161
x	-	-	-	-	-	-	3

Klemens Pozisyonları
 Terminal Box Positions
 Klemmenkasten Positionen

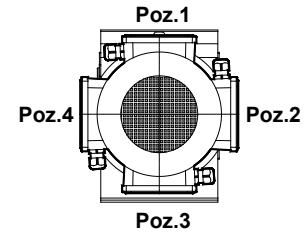

63-71-80-90-100-112
 Tip / Type / Typ

KR273.05

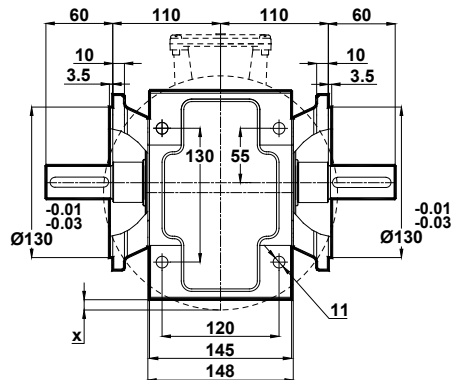
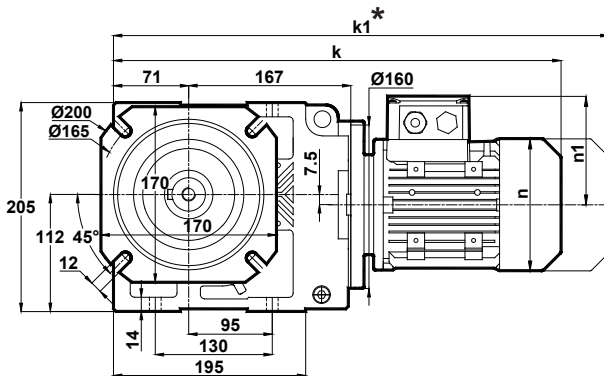

x: Motor Ayak bağlantı yüzeyinin altında ise
 x: If Motor is lower than foot mounting plane
 x: Wenn der Motor unter der Fußmontageebene ist

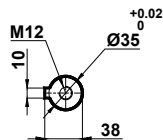

	63	71	80	90S	90L	100L	112M
k	432	459	493	532	532	580	604
k1	493	550	586	635.5	635.5	688.5	708.5
n	121	137	155	176	176	193	215
n1	97	112	123	132	132	149	161
x	-	-	-	-	-	-	3

Opsiyonel flanş ölçüleri için sayfa 587'ye bakınız.
 Please see on page 587 for optional flange dimensions
 Siehe Seite 587 für auswählbare Flanschabmessungen

* "k1" Ölçüsü frenli redüktörlere aittir.
 Dimension "k1" is for motors with brake.
 Maße "k1" ist für Bremsenmotoren.

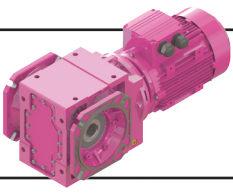

Ölçü Sayfaları Dimension Pages Abmessungsseiten

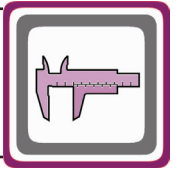

-Mil ucu çektirme deliği DIN 332 sayfa 2 / Tapped center hole to DIN 332, sheet 2 / Zentrierung mit Gewinde DIN 332, Blatt 2

KR273.08

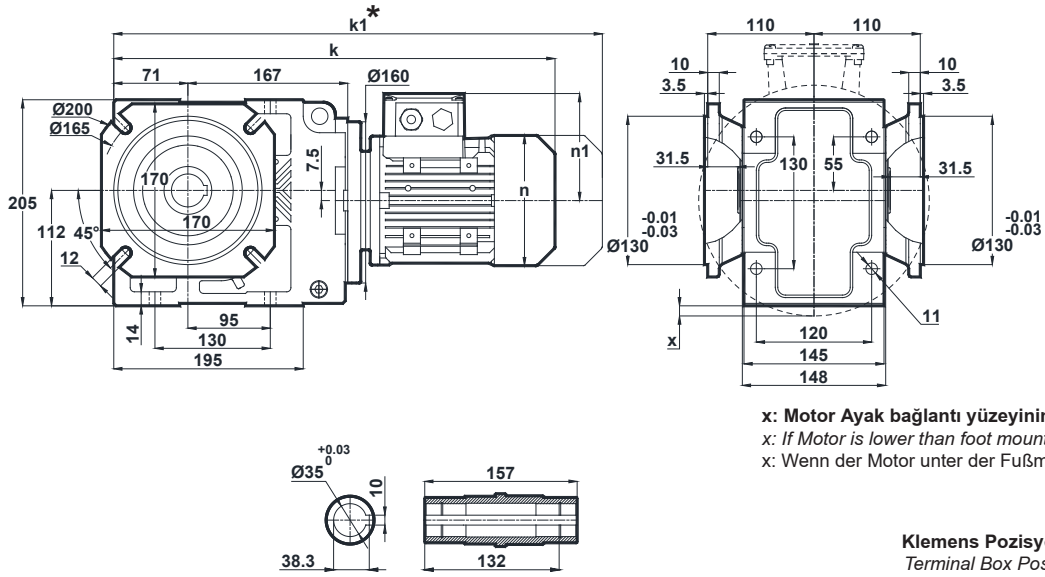

x: Motor Ayak bağlantı yüzeyinin altında ise
x: If Motor is lower than foot mounting plane
x: Wenn der Motor unter der Fußmontageebene ist

Klemens Pozisyonları
Terminal Box Positions
Klemmenkasten Positionen

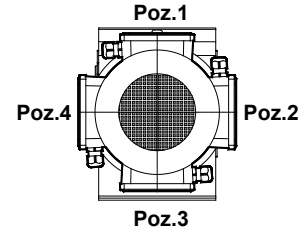

63-71- 80-90-100-112
Tip / Type / Typ

	63	71	80	90S	90L	100L	112M
k	432	459	493	532	532	580	604
k1	493	550	586	635.5	635.5	688.5	708.5
n	121	137	155	176	176	193	215
n1	97	112	123	132	132	149	161
x	-	-	-	-	-	-	3

Opsiyonel flanş ölçüleri için sayfa 587'ye bakınız.
Please see on page 587 for optional flange dimensions
Siehe Seite 587 für auswählbare Flanschabmessungen

* " k1 " Ölçüsü frenli redüktörlere aittir.
Dimension " k1 " is for motors with brake.
Maße " k1 " ist für Bremsenmotoren.

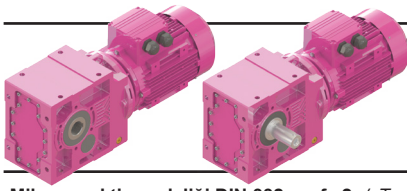

Ölçü Sayfaları

Dimension Pages

Abmessungsseiten

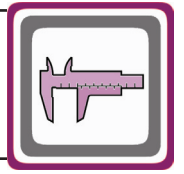

-Mil ucu çektirme deliği DIN 332 sayfa 2 / Tapped center hole to DIN 332, sheet 2 / Zentrierung mit Gewinde DIN 332, Blatt 2

KR275.00
KR276.00

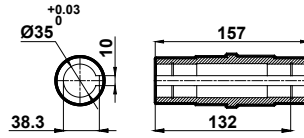
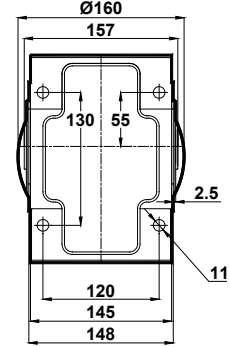
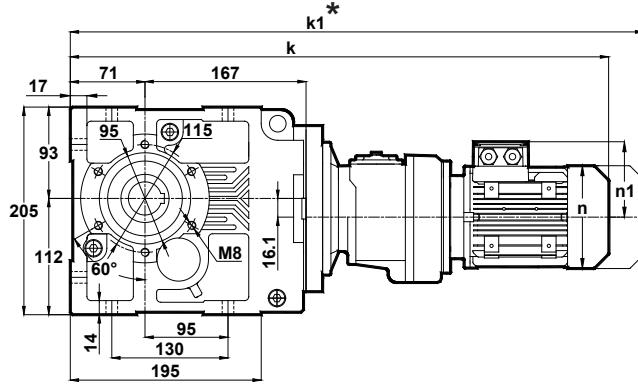

	63	71	80
k	581.5	610	644
k1	642.5	701	737
n	121	137	155
n1	97	112	123

Klemens Pozisyonları
Terminal Box Positions
Klemmenkasten Positionen

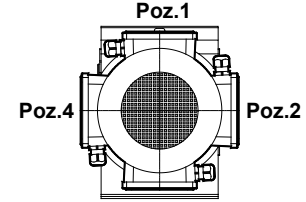

Poz.3
63-71-80
Tip / Type / Typ

KR275.01
KR276.01

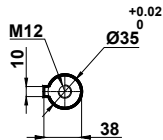
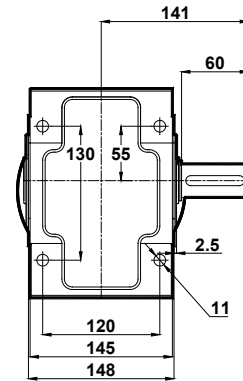
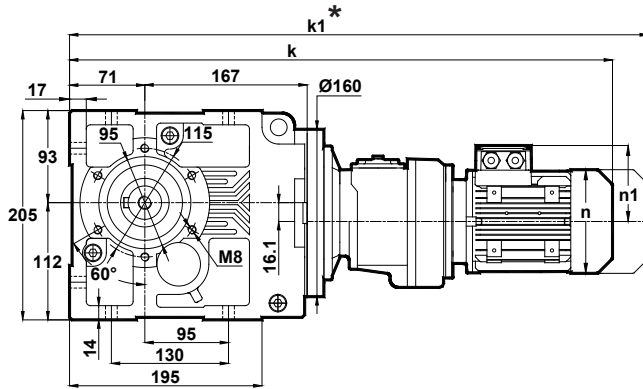

	63	71	80
k	581.5	610	644
k1	642.5	701	737
n	121	137	155
n1	97	112	123

* " k1 " Ölçüsü frenli redüktörlere aittir.
Dimension " k1 " is for motors with brake.
Maße " k1 " ist für Bremsenmotoren.

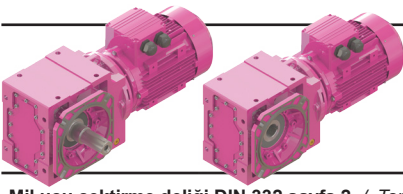

Ölçü Sayfaları

Dimension Pages

Abmessungsseiten

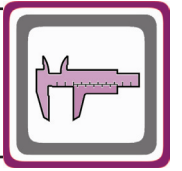

-Mil ucu çektirme deliği DIN 332 sayfa 2 / Tapped center hole to DIN 332, sheet 2 / Zentrierung mit Gewinde DIN 332, Blatt 2

KR275.02
KR276.02

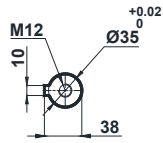
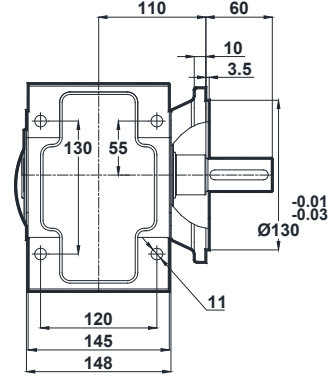
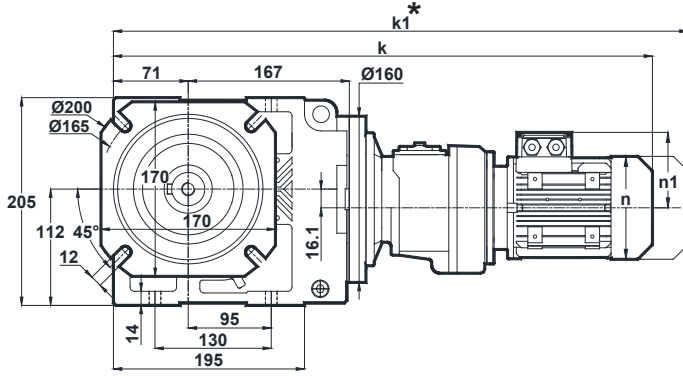

Klemens Pozisyonları
Terminal Box Positions
Klemmenkasten Positionen

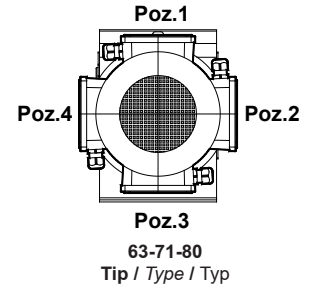

	63	71	80
k	581.5	610	644
k1	642.5	701	737
n	121	137	155
n1	97	112	123

Opsiyonel flanş ölçüleri için sayfa 587'ye bakınız.
Please see on page 587 for optional flange dimensions
Siehe Seite 587 für auswählbare Flanschabmessungen

KR275.03
KR276.03

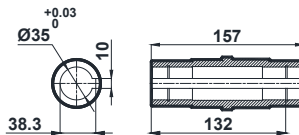
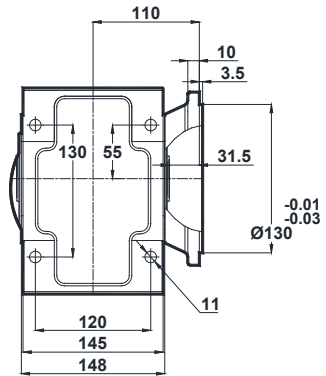
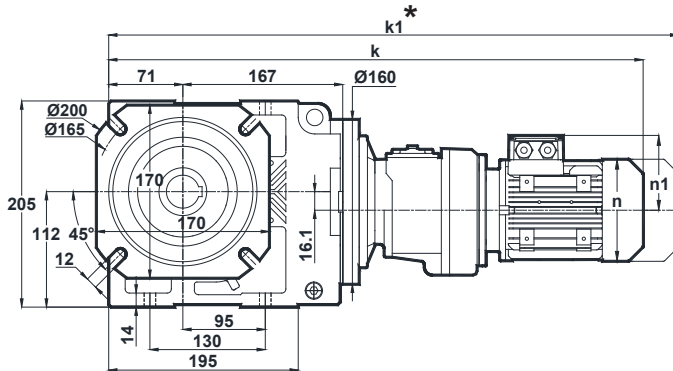

	63	71	80
k	581.5	610	644
k1	642.5	701	737
n	121	137	155
n1	97	112	123

Opsiyonel flanş ölçüleri için sayfa 587'ye bakınız.
Please see on page 587 for optional flange dimensions
Siehe Seite 587 für auswählbare Flanschabmessungen

* " k1 " Ölçüsü frenli redüktörlere aittir.
Dimension " k1 " is for motors with brake.
Maße " k1 " ist für Bremsenmotoren.

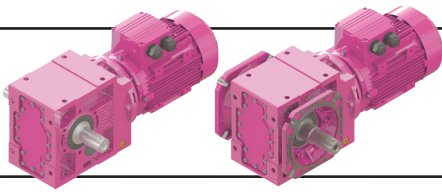

Ölçü Sayfaları Dimension Pages Abmessungsseiten

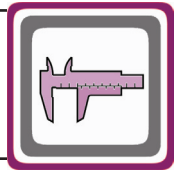

-Mil ucu çektirme deliği DIN 332 sayfa 2 / Tapped center hole to DIN 332, sheet 2 / Zentrierung mit Gewinde DIN 332, Blatt 2

KR275.04
KR276.04

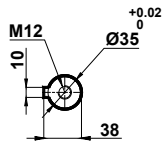
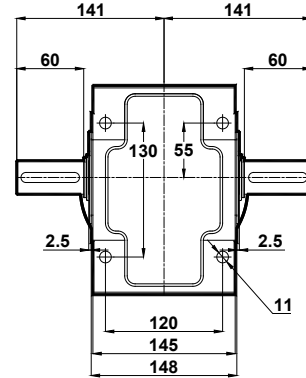
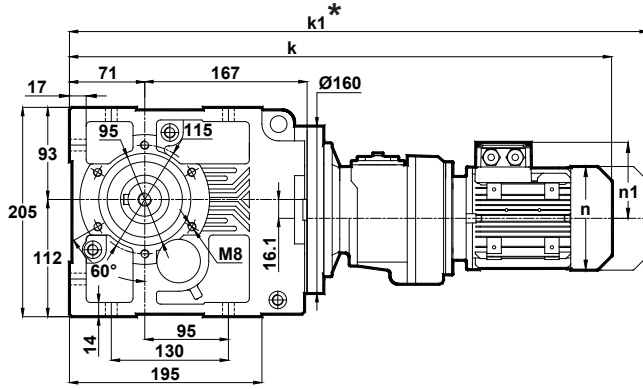

	63	71	80
k	581.5	610	644
k1	642.5	701	737
n	121	137	155
n1	97	112	123

Klemens Pozisyonları
Terminal Box Positions
Klemmenkasten Positionen

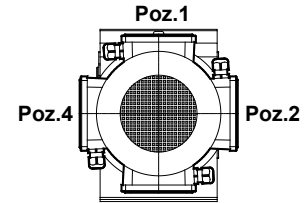

Poz.3
63-71-80
Tip / Type / Typ

KR275.05
KR276.05

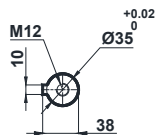
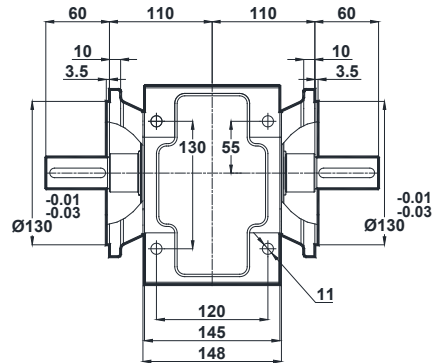
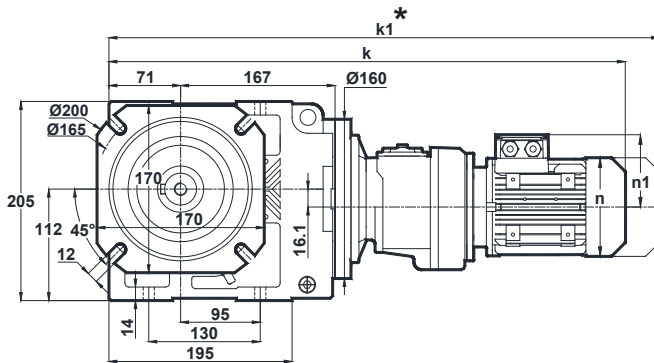

	63	71	80
k	581.5	610	644
k1	642.5	701	737
n	121	137	155
n1	97	112	123

Opsiyonel flanş ölçüleri için sayfa 587'ye bakınız.
Please see on page 587 for optional flange dimensions
Siehe Seite 587 für auswählbare Flanschabmessungen

* " k1 " Ölçüsü frenli redüktörlere aittir.
Dimension " k1 " is for motors with brake.
Maße " k1 " ist für Bremsenmotoren.

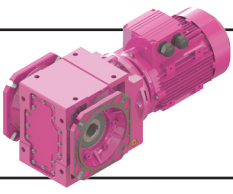

Ölçü Sayfaları Dimension Pages Abmessungsseiten

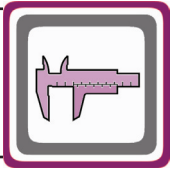

-Mil ucu çektirme deliği DIN 332 sayfa 2 / Tapped center hole to DIN 332, sheet 2 / Zentrierung mit Gewinde DIN 332, Blatt 2

KR275.08
KR276.08

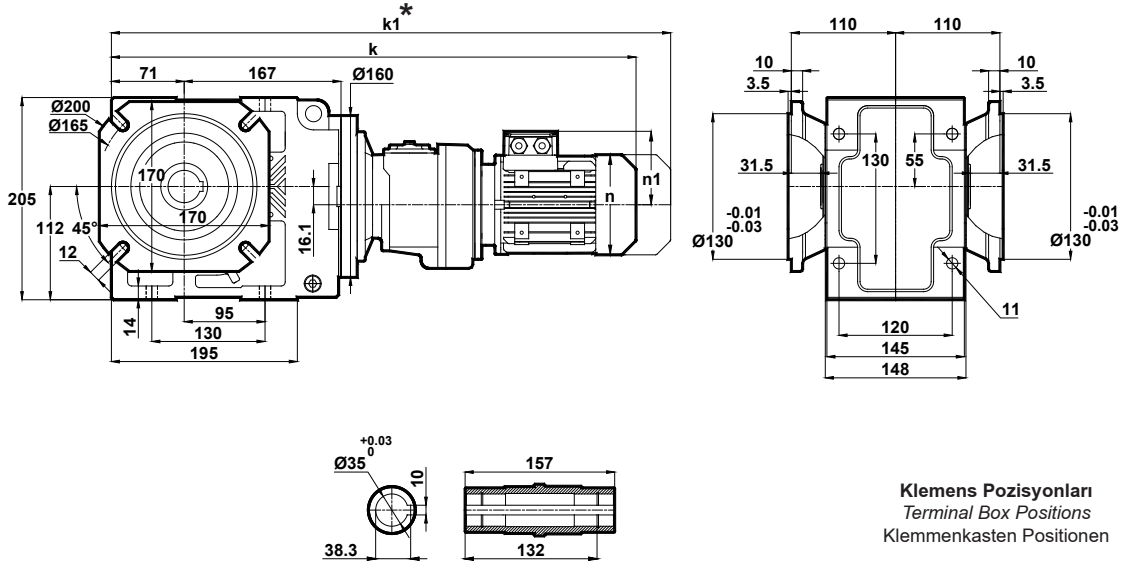

	63	71	80
k	581.5	610	644
k1	642.5	701	737
n	121	137	155
n1	97	112	123

Klemens Pozisyonları
Terminal Box Positions
Klemmenkasten Positionen

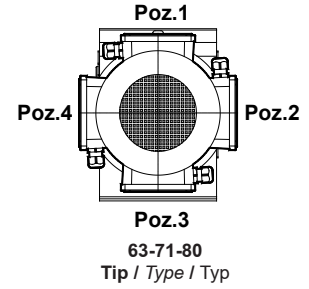

Opsiyonel flanş ölçüleri için sayfa 587'ye bakınız.
Please see on page 587 for optional flange dimensions
Siehe Seite 587 für auswählbare Flanschabmessungen

* " k1 " Ölçüsü frenli redüktörlere aittir.
Dimension " k1 " is for motors with brake.
Maße " k1 " ist für Bremsenmotoren.

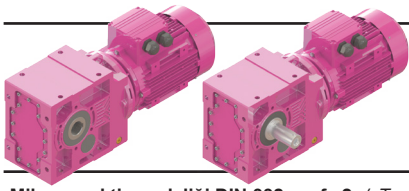

Ölçü Sayfaları

Dimension Pages

Abmessungsseiten

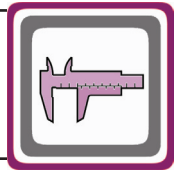

-Mil ucu çektirme deliği DIN 332 sayfa 2 / Tapped center hole to DIN 332, sheet 2 / Zentrierung mit Gewinde DIN 332, Blatt 2

KR283.00

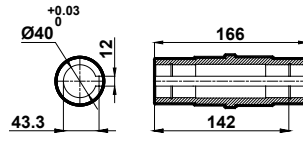
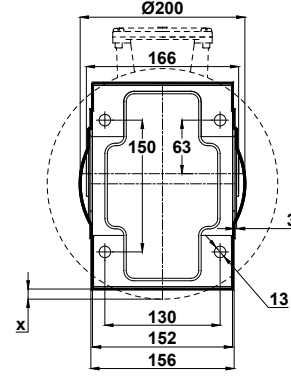
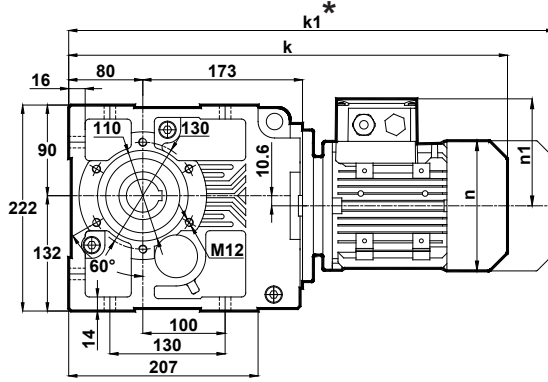

Klemens Pozisyonları
Terminal Box Positions
Klemmenkasten Positionen

	71	80	90S	90L	100L	112M	132S	132M
k	465	499	538	538	586	610	696.5	696.5
k1	556	592	641.5	641.5	694.5	714.5	826.5	826.5
n	137	155	176	176	193	215	257	257
n1	112	123	132	132	149	161	181	181
x	-	-	-	-	-	-	7.1	7.1

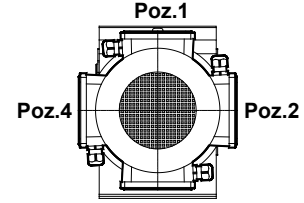

Poz.1
Poz.2
Poz.3
Poz.4
71-80-90-100-112-132
Tip / Type / Typ

KR283.01

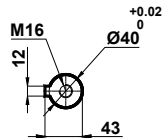
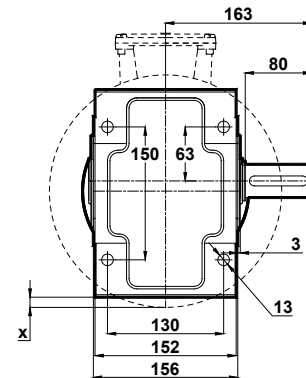
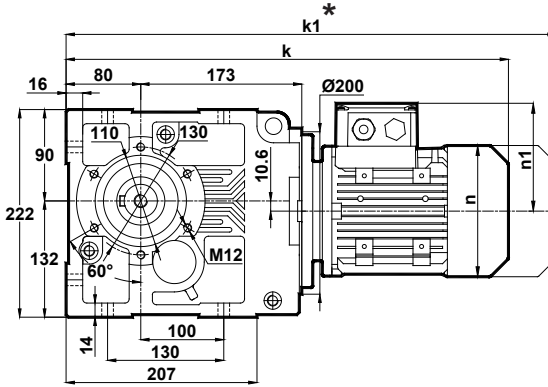

	71	80	90S	90L	100L	112M	132S	132M
k	465	499	538	538	586	610	696.5	696.5
k1	556	592	641.5	641.5	694.5	714.5	826.5	826.5
n	137	155	176	176	193	215	257	257
n1	112	123	132	132	149	161	181	181
x	-	-	-	-	-	-	7.1	7.1

* "k1" Ölçüsü frenli redüktörlere aittir.
Dimension "k1" is for motors with brake.
Maße "k1" ist für Bremsenmotoren.

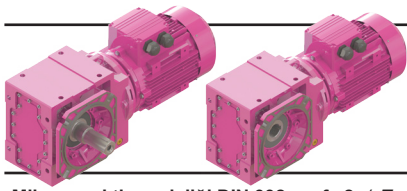

Ölçü Sayfaları Dimension Pages Abmessungsseiten

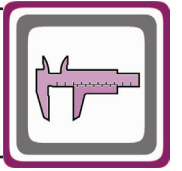

-Mil ucu çektirme deliği DIN 332 sayfa 2 / Tapped center hole to DIN 332, sheet 2 / Zentrierung mit Gewinde DIN 332, Blatt 2

KR283.02

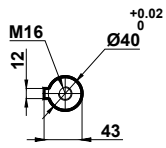
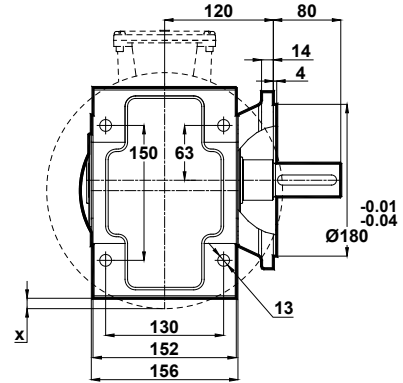
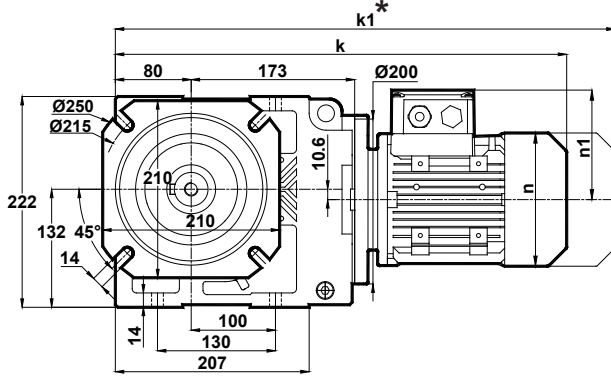

Klemens Pozisyonları
Terminal Box Positions
Klemmenkasten Positionen

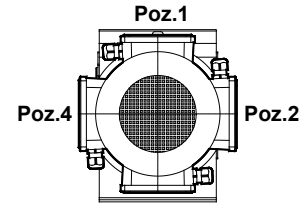

Poz.1

71-80-90-100-112-132

Tip / Type / Typ

	71	80	90S	90L	100L	112M	132S	132M
k	465	499	538	538	586	610	696.5	696.5
k1	556	592	641.5	641.5	694.5	714.5	826.5	826.5
n	137	155	176	176	193	215	257	257
n1	112	123	132	132	149	161	181	181
x	-	-	-	-	-	-	7.1	7.1

Opsiyonel flanş ölçüleri için sayfa 587'ye bakınız.
Please see on page 587 for optional flange dimensions
Siehe Seite 587 für auswählbare Flanschabmessungen

KR283.03

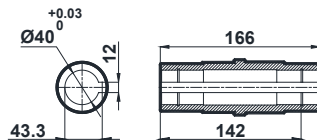
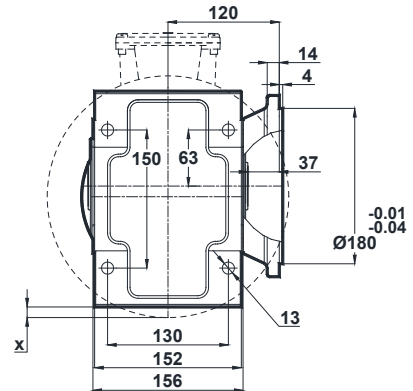
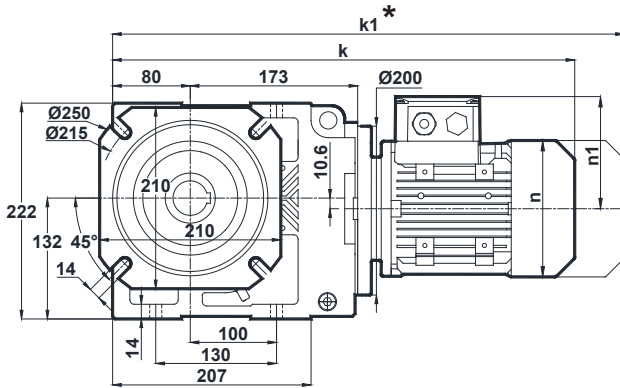

	71	80	90S	90L	100L	112M	132S	132M
k	465	499	538	538	586	610	696.5	696.5
k1	556	592	641.5	641.5	694.5	714.5	826.5	826.5
n	137	155	176	176	193	215	257	257
n1	112	123	132	132	149	161	181	181
x	-	-	-	-	-	-	7.1	7.1

Opsiyonel flanş ölçüleri için sayfa 587'ye bakınız.
Please see on page 587 for optional flange dimensions
Siehe Seite 587 für auswählbare Flanschabmessungen

* "k1" Ölçüsü frenli redüktörlere aittir.
Dimension "k1" is for motors with brake.
Maße "k1" ist für Bremsenmotoren.

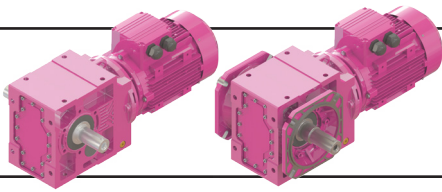

Ölçü Sayfaları Dimension Pages Abmessungsseiten

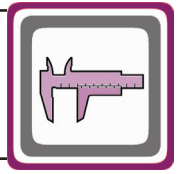

-Mil ucu çektirme deliği DIN 332 sayfa 2 / Tapped center hole to DIN 332, sheet 2 / Zentrierung mit Gewinde DIN 332, Blatt 2

KR283.04

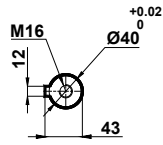
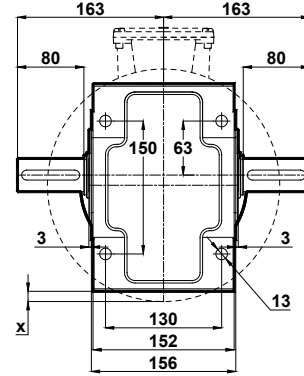
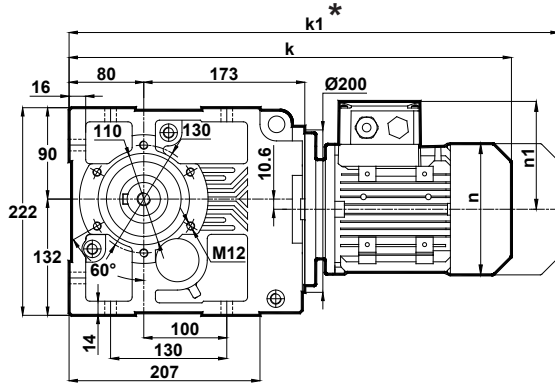

Klemens Pozisyonları
Terminal Box Positions
Klemmenkasten Positionen

	71	80	90S	90L	100L	112M	132S	132M
k	465	499	538	538	586	610	696.5	696.5
k1	556	592	641.5	641.5	694.5	714.5	826.5	826.5
n	137	155	176	176	193	215	257	257
n1	112	123	132	132	149	161	181	181
x	-	-	-	-	-	-	7.1	7.1

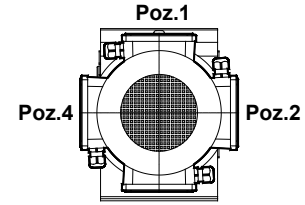

Poz.3
71-80-90-100-112-132
Tip / Type / Typ

KR283.05

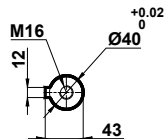
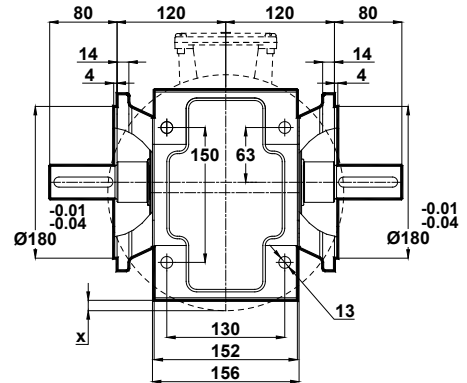
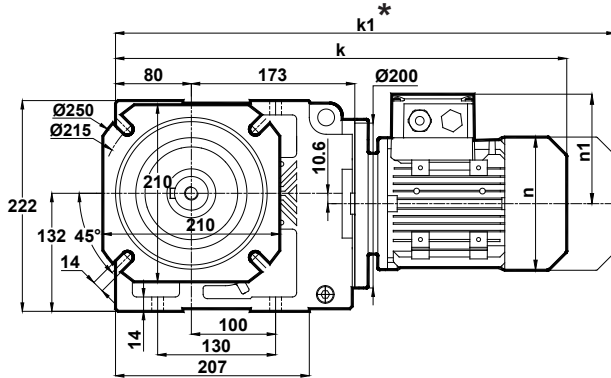

	71	80	90S	90L	100L	112M	132S	132M
k	465	499	538	538	586	610	696.5	696.5
k1	556	592	641.5	641.5	694.5	714.5	826.5	826.5
n	137	155	176	176	193	215	257	257
n1	112	123	132	132	149	161	181	181
x	-	-	-	-	-	-	7.1	7.1

Opsiyonel flanş ölçüleri için sayfa 587'ye bakınız.
Please see on page 587 for optional flange dimensions
Siehe Seite 587 für auswählbare Flanschabmessungen

* "k1" Ölçüsü frenli redüktörlere aittir.
Dimension "k1" is for motors with brake.
Maße "k1" ist für Bremsenmotoren.

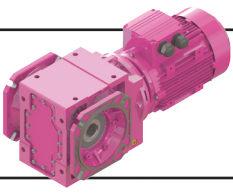

Ölçü Sayfaları Dimension Pages Abmessungsseiten

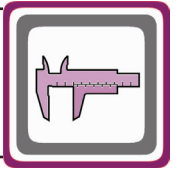

-Mil ucu çektirme deliği DIN 332 sayfa 2 / Tapped center hole to DIN 332, sheet 2 / Zentrierung mit Gewinde DIN 332, Blatt 2

KR283.08

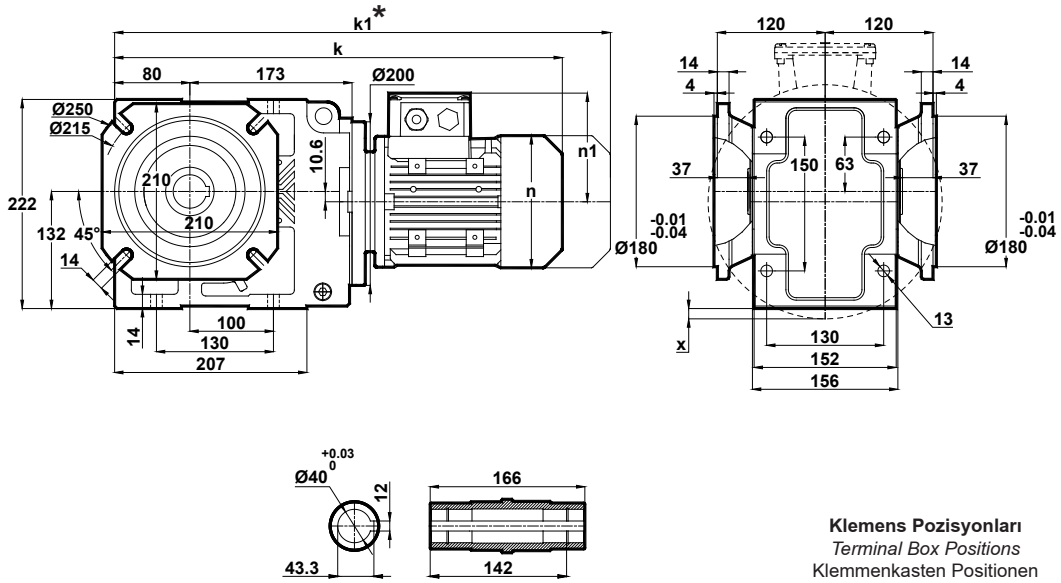

Klemens Pozisyonları
Terminal Box Positions
Klemmenkasten Positionen

	71	80	90S	90L	100L	112M	132S	132M
k	465	499	538	538	586	610	696.5	696.5
k1	556	592	641.5	641.5	694.5	714.5	826.5	826.5
n	137	155	176	176	193	215	257	257
n1	112	123	132	132	149	161	181	181
x	-	-	-	-	-	-	7.1	7.1

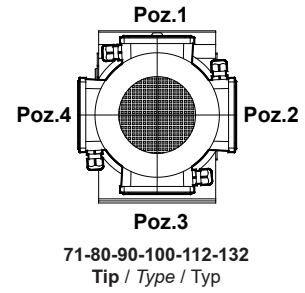

Opsiyonel flanş ölçüleri için sayfa 587'ye bakınız.
Please see on page 587 for optional flange dimensions
Siehe Seite 587 für auswählbare Flanschabmessungen

* "k1" Ölçüsü frenli redüktörlere aittir.
Dimension "k1" is for motors with brake.
Maße "k1" ist für Bremsenmotoren.

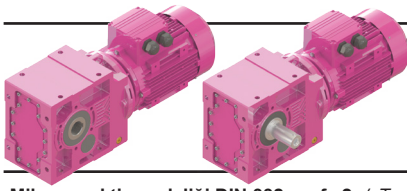

Ölçü Sayfaları

Dimension Pages

Abmessungsseiten

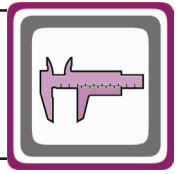

-Mil ucu çekirme deliği DIN 332 sayfa 2 / Tapped center hole to DIN 332, sheet 2 / Zentrierung mit Gewinde DIN 332, Blatt 2

KR284.00

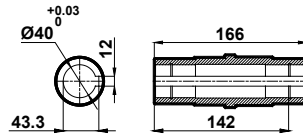
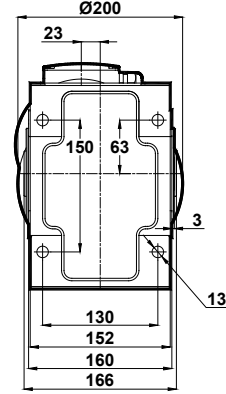
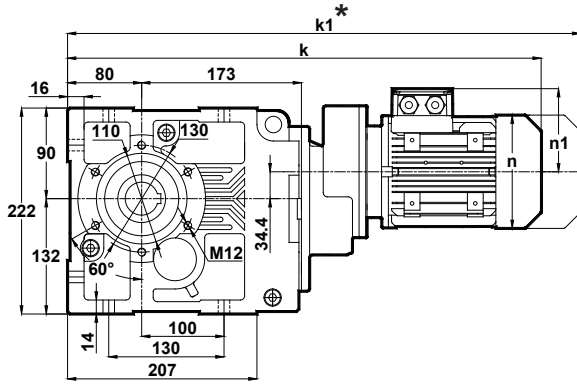

Klemens Pozisyonları
Terminal Box Positions
Klemmenkasten Positionen

	63	71	80
k	517	544	578
k1	578	635	671
n	121	137	155
n1	97	112	123

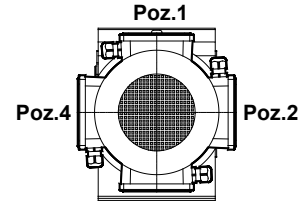

Poz.3
63-71-80
Tip / Type / Typ

KR284.01

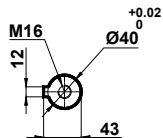
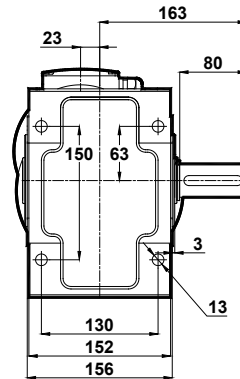
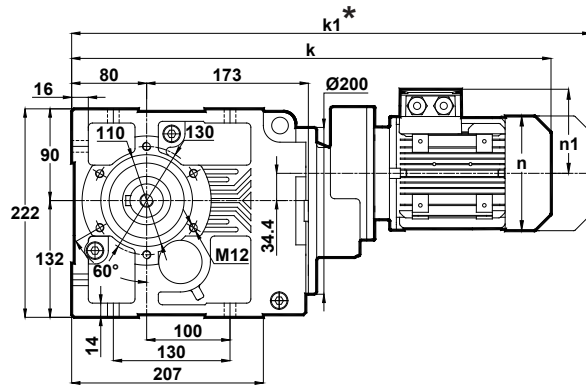

	63	71	80
k	517	544	578
k1	578	635	671
n	121	137	155
n1	97	112	123

* " k1 " Ölçüsü frenli redüktörlere aittir.
Dimension " k1 " is for motors with brake.
Maße " k1 " ist für Bremsenmotoren.

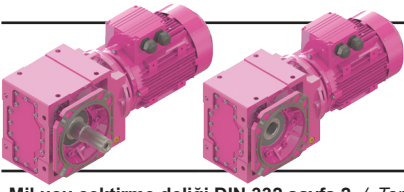

Ölçü Sayfaları Dimension Pages Abmessungsseiten

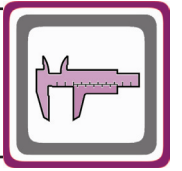

-Mil ucu çektirme deliği DIN 332 sayfa 2 / Tapped center hole to DIN 332, sheet 2 / Zentrierung mit Gewinde DIN 332, Blatt 2

KR284.02

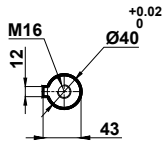
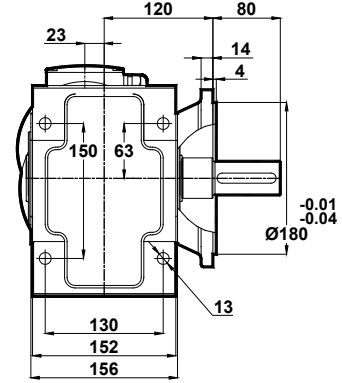
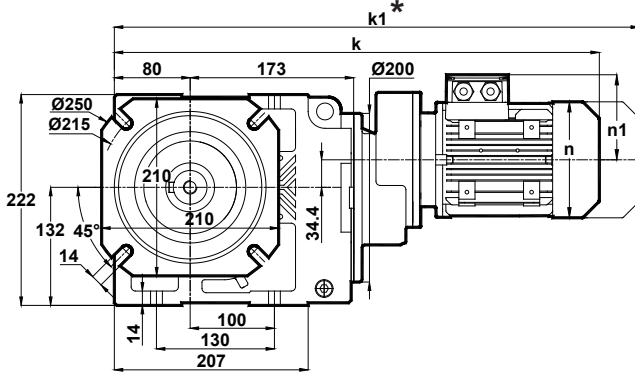

Klemens Pozisyonları
Terminal Box Positions
Klemmenkasten Positionen

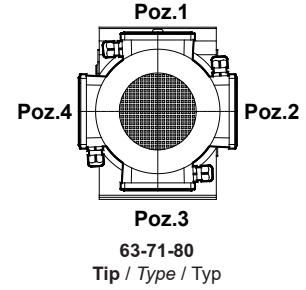

	63	71	80
k	517	544	578
k1	578	635	671
n	121	137	155
n1	97	112	123

Opsiyonel flanş ölçüleri için sayfa 587'ye bakınız.
Please see on page 587 for optional flange dimensions
Siehe Seite 587 für auswählbare Flanschabmessungen

KR284.03

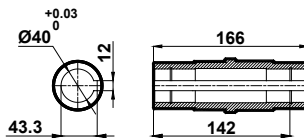
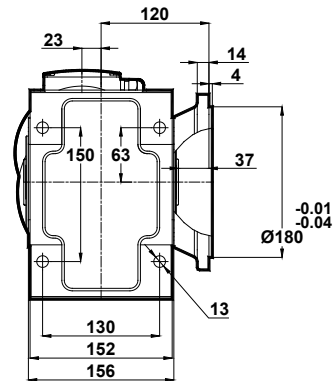
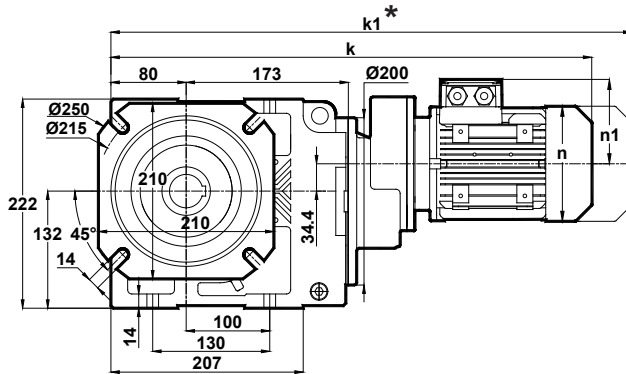

	63	71	80
k	517	544	578
k1	578	635	671
n	121	137	155
n1	97	112	123

Opsiyonel flanş ölçüleri için sayfa 587'ye bakınız.
Please see on page 587 for optional flange dimensions
Siehe Seite 587 für auswählbare Flanschabmessungen

* " k1 " Ölçüsü frenli redüktörlere aittir.
Dimension " k1 " is for motors with brake.
Maße " k1 " ist für Bremsenmotoren.

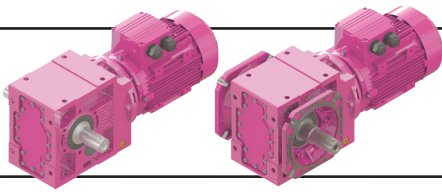

Ölçü Sayfaları Dimension Pages Abmessungsseiten

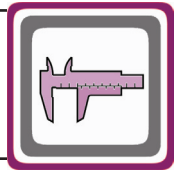

-Mil ucu çekirme deliği DIN 332 sayfa 2 / Tapped center hole to DIN 332, sheet 2 / Zentrierung mit Gewinde DIN 332, Blatt 2

KR284.04

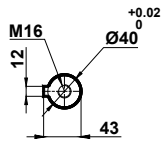
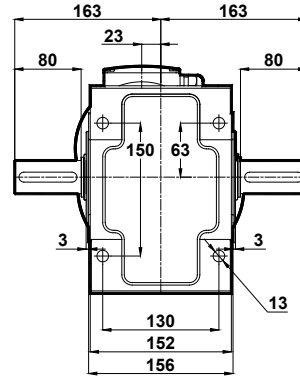
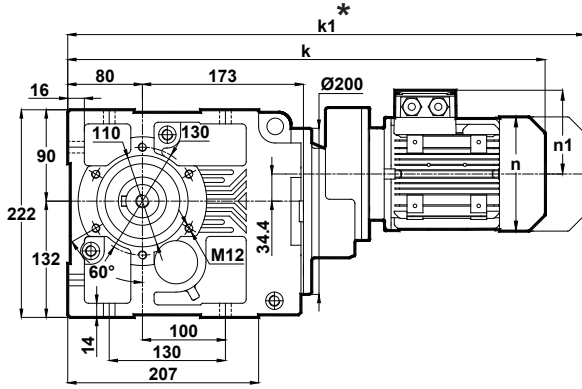

	63	71	80
k	517	544	578
k1	578	635	671
n	121	137	155
n1	97	112	123

Klemens Pozisyonları
Terminal Box Positions
Klemmenkasten Positionen

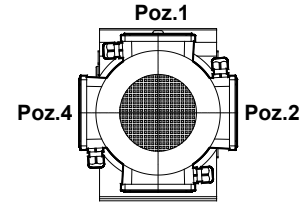

Poz.3

63-71-80

Tip / Type / Typ

KR284.05

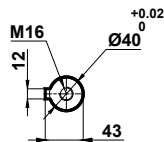
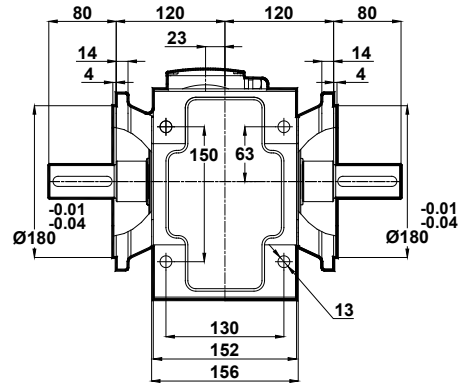
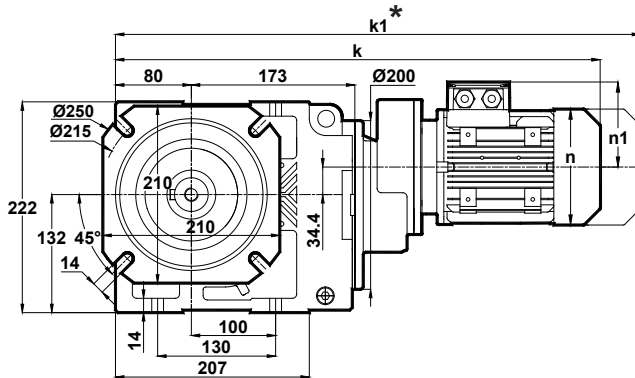

	63	71	80
k	517	544	578
k1	578	635	671
n	121	137	155
n1	97	112	123

Opsiyonel flanş ölçüleri için sayfa 587'ye bakınız.
Please see on page 587 for optional flange dimensions
Siehe Seite 587 für auswählbare Flanschabmessungen

* " k1 " Ölçüsü frenli redüktörlere aittir.
Dimension " k1 " is for motors with brake.
Maße " k1 " ist für Bremsenmotoren.

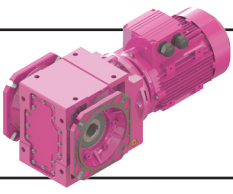

Ölçü Sayfaları Dimension Pages Abmessungenseiten

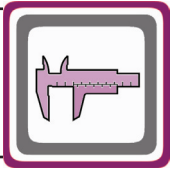

-Mil ucu çektirme deliği DIN 332 sayfa 2 / Tapped center hole to DIN 332, sheet 2 / Zentrierung mit Gewinde DIN 332, Blatt 2

KR284.08

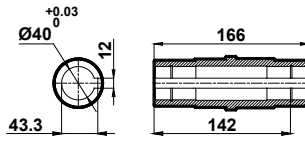
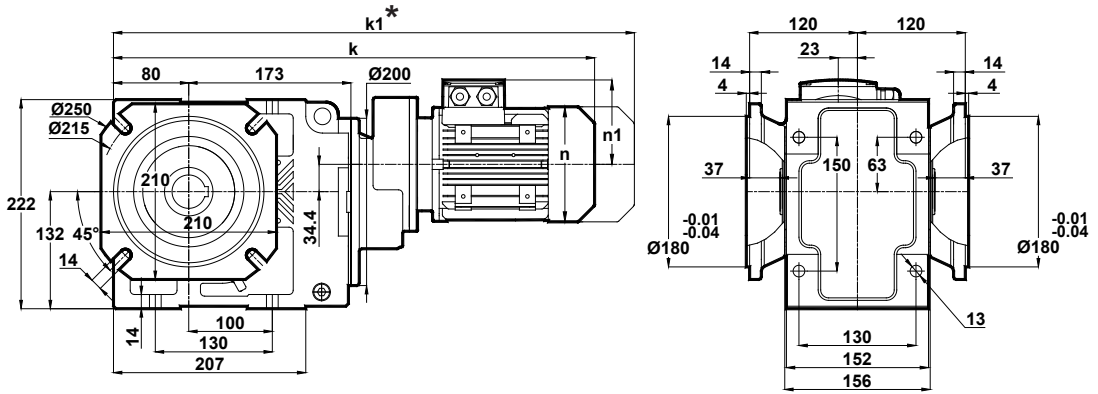

Klemens Pozisyonları
Terminal Box Positions
Klemmenkasten Positionen

	63	71	80
k	517	544	578
k1	578	635	671
n	121	137	155
n1	97	112	123

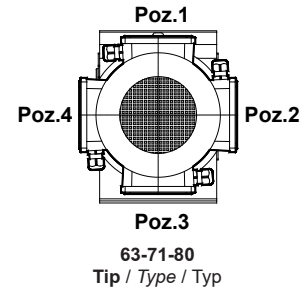

Opsiyonel flanş ölçüleri için sayfa 587'ye bakınız.
Please see on page 587 for optional flange dimensions
Siehe Seite 587 für auswählbare Flanschabmessungen

* "k1" Ölçüsü frenli redüktörlere aittir.
Dimension "k1" is for motors with brake.
Maße "k1" ist für Bremsenmotoren.

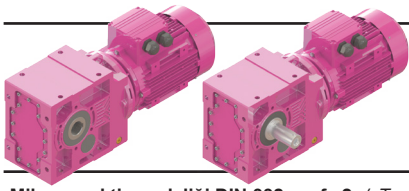

Ölçü Sayfaları

Dimension Pages

Abmessungsseiten

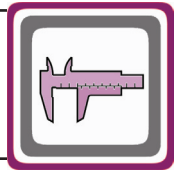

-Mil ucu çekirme deliği DIN 332 sayfa 2 / Tapped center hole to DIN 332, sheet 2 / Zentrierung mit Gewinde DIN 332, Blatt 2

KR285.00
KR286.00

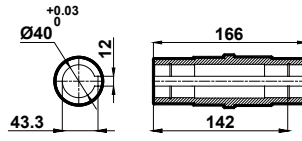
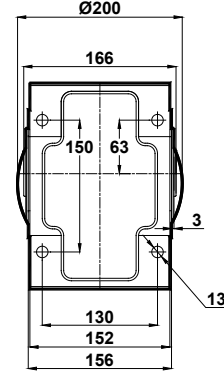
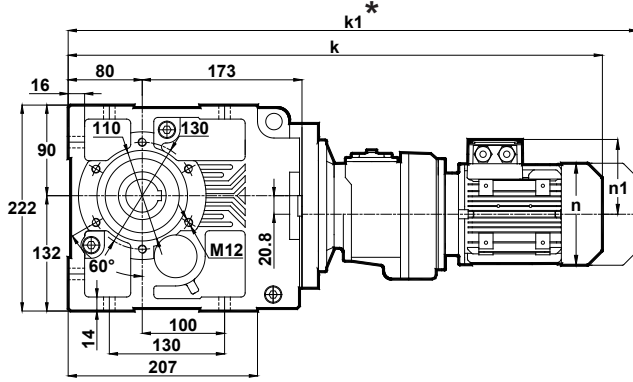

Klemens Pozisyonları
Terminal Box Positions
Klemmenkasten Positionen

	63
k	621.5
k1	682.5
n	121
n1	97

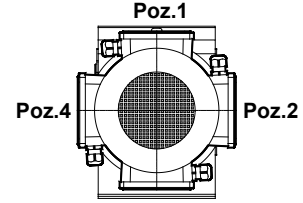

Poz.3
63
Tip / Type / Typ

KR285.01
KR286.01

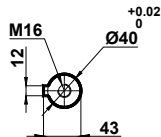
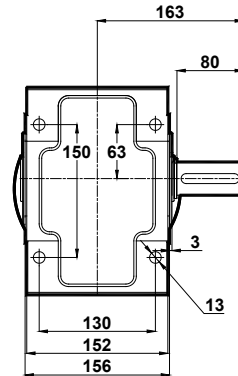
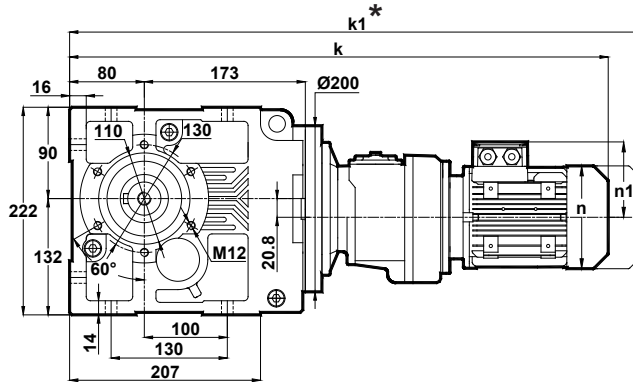

	63
k	621.5
k1	682.5
n	121
n1	97

* "k1" Ölçüsü frenli redüktörlere aittir.
Dimension "k1" is for motors with brake.
Maße "k1" ist für Bremsenmotoren.

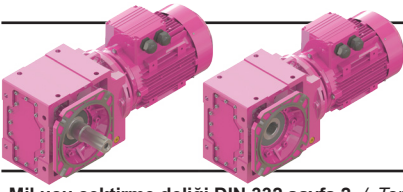

Ölçü Sayfaları Dimension Pages Abmessungenseiten

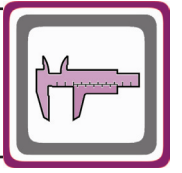

-Mil ucu çektirme deliği DIN 332 sayfa 2 / Tapped center hole to DIN 332, sheet 2 / Zentrierung mit Gewinde DIN 332, Blatt 2

KR285.02
KR286.02

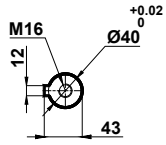
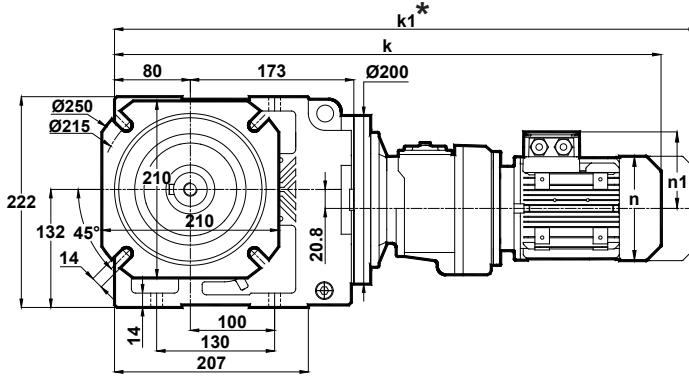

	63
k	621.5
k1	682.5
n	121
n1	97

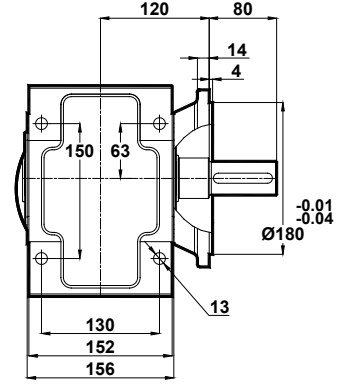

Klemens Pozisyonları
Terminal Box Positions
Klemmenkasten Positionen

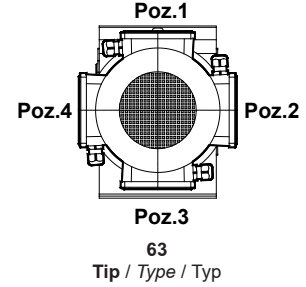

Opsiyonel flanş ölçüleri için sayfa 587'ye bakınız.
Please see on page 587 for optional flange dimensions
Siehe Seite 587 für auswählbare Flanschabmessungen

KR285.03
KR286.03

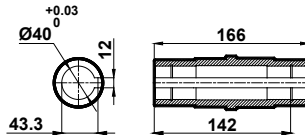
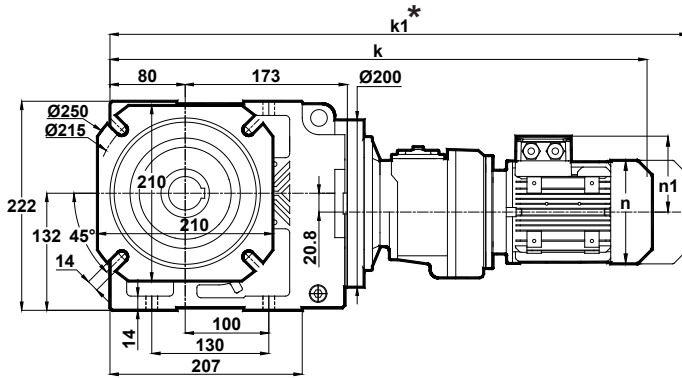

	63
k	621.5
k1	682.5
n	121
n1	97

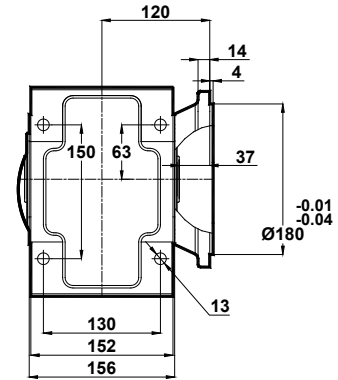

Opsiyonel flanş ölçüleri için sayfa 587'ye bakınız.
Please see on page 587 for optional flange dimensions
Siehe Seite 587 für auswählbare Flanschabmessungen

* "k1" Ölçüsü frenli redüktörlere aittir.
Dimension "k1" is for motors with brake.
Maße "k1" ist für Bremsenmotoren.

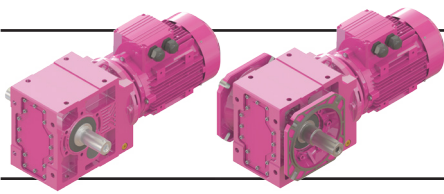

Ölçü Sayfaları Dimension Pages Abmessungsseiten

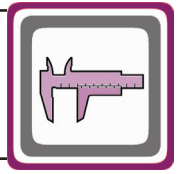

-Mil ucu çektirme deliği DIN 332 sayfa 2 / Tapped center hole to DIN 332, sheet 2 / Zentrierung mit Gewinde DIN 332, Blatt 2

KR285.04
KR286.04

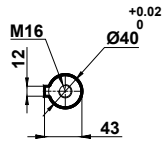
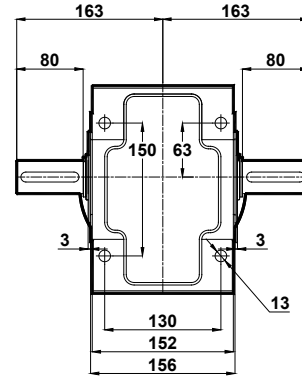
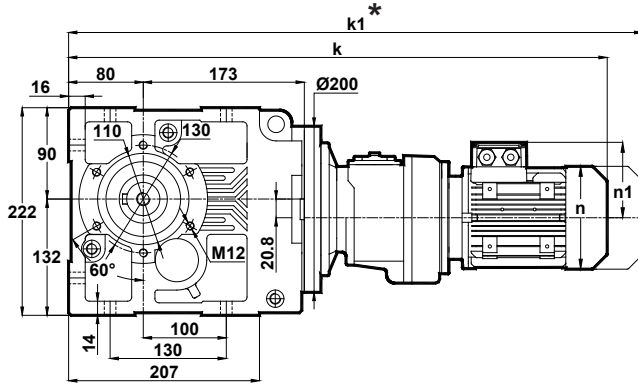

	63
k	621.5
k1	682.5
n	121
n1	97

Klemens Pozisyonları
Terminal Box Positions
Klemmenkasten Positionen

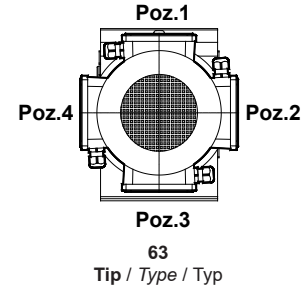

KR285.05
KR286.05

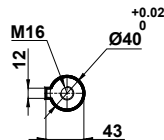
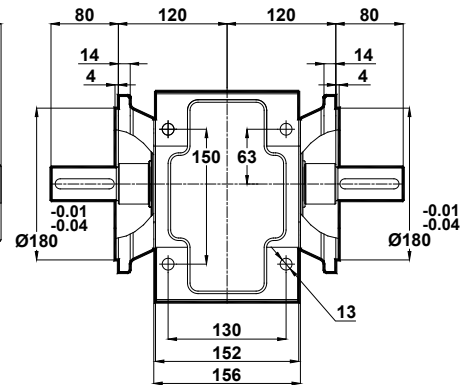
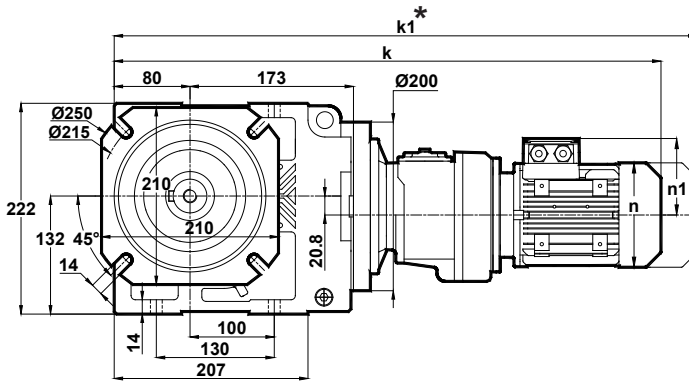

	63
k	621.5
k1	682.5
n	121
n1	97

Opsiyonel flanş ölçüleri için sayfa 587'ye bakınız.
Please see on page 587 for optional flange dimensions
Siehe Seite 587 für auswählbare Flanschabmessungen

* "k1" Ölçüsü frenli redüktörlere aittir.
Dimension "k1" is for motors with brake.
Maße "k1" ist für Bremsenmotoren.

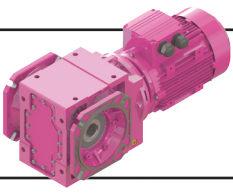

Ölçü Sayfaları Dimension Pages Abmessungsseiten

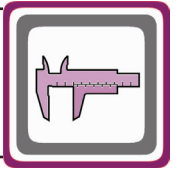

-Mil ucu çektirme deliği DIN 332 sayfa 2 / Tapped center hole to DIN 332, sheet 2 / Zentrierung mit Gewinde DIN 332, Blatt 2

KR285.08
KR286.08

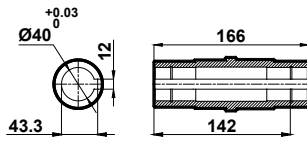
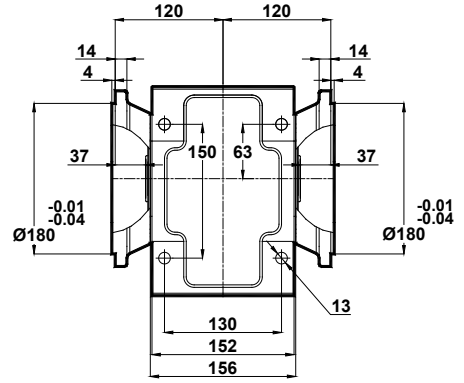
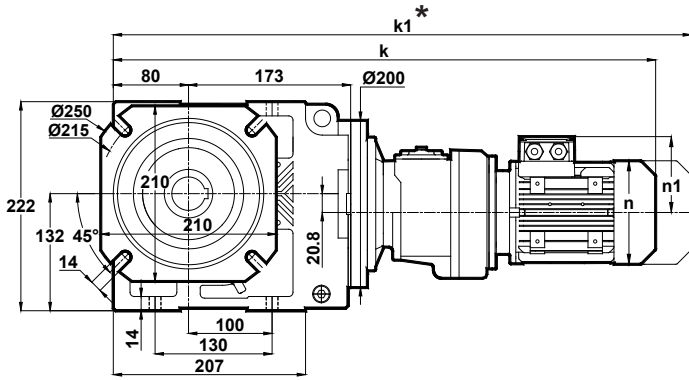

Klemens Pozisyonları
Terminal Box Positions
Klemmenkasten Positionen

	63
k	621.5
k1	682.5
n	121
n1	97

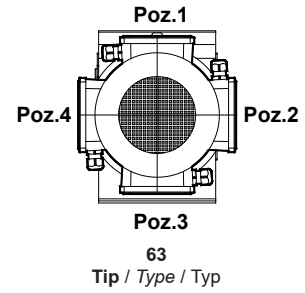

Opsiyonel flanş ölçüleri için sayfa 587'ye bakınız.
Please see on page 587 for optional flange dimensions
Siehe Seite 587 für auswählbare Flanschabmessungen

* " k1 " Ölçüsü frenli redüktörlere aittir.
Dimension " k1 " is for motors with brake.
Maße " k1 " ist für Bremsenmotoren.

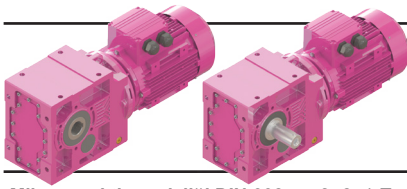

Ölçü Sayfaları

Dimension Pages

Abmessungsseiten

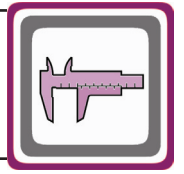

-Mil ucu çekirme deliği DIN 332 sayfa 2 / Tapped center hole to DIN 332, sheet 2 / Zentrierung mit Gewinde DIN 332, Blatt 2

KR373.00

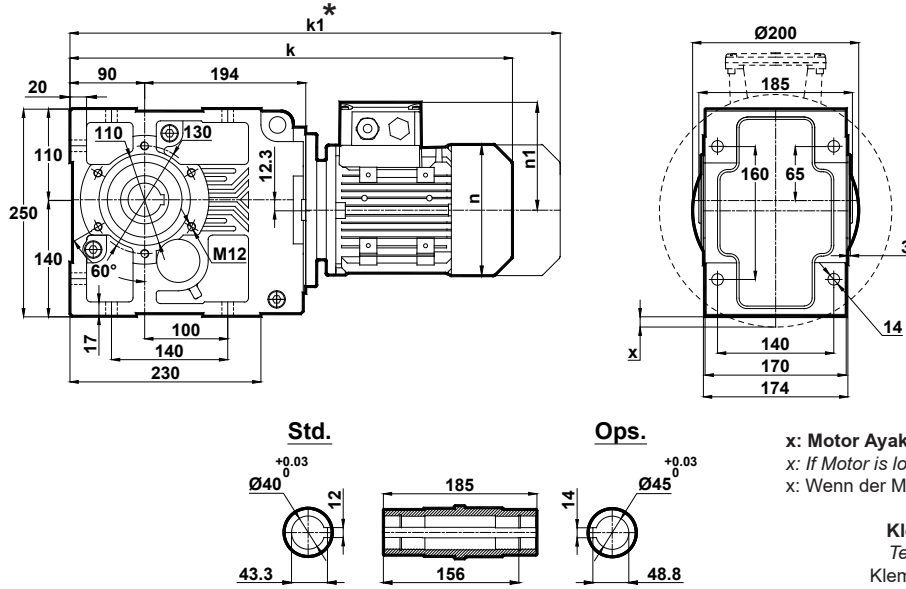

x: Motor Ayak bağlantı yüzeyinin altında ise
x: If Motor is lower than foot mounting plane
x: Wenn der Motor unter der Fußmontageebene ist

Klemens Pozisyonları
Terminal Box Positions
Klemmenkasten Positionen

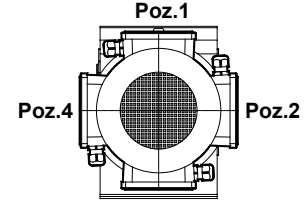

Poz.3
71-80-90-100-112-132
Tip / Type / Typ

	71	80	90S	90L	100L	112M	132S	132M
k	496	530	569	569	617	641	727.5	727.5
k1	587	623	672.5	672.5	725.5	745.5	857.5	857.5
n	137	155	176	176	193	215	257	257
n1	112	123	132	132	149	161	181	181
x	-	-	-	-	-	-	0.8	0.8

KR373.01

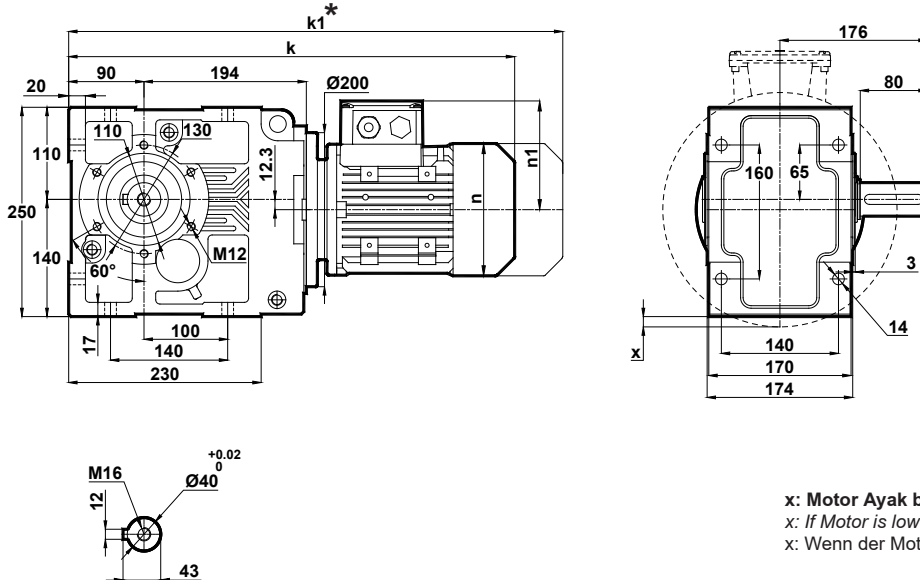

x: Motor Ayak bağlantı yüzeyinin altında ise
x: If Motor is lower than foot mounting plane
x: Wenn der Motor unter der Fußmontageebene ist

	71	80	90S	90L	100L	112M	132S	132M
k	496	530	569	569	617	641	727.5	727.5
k1	587	623	672.5	672.5	725.5	745.5	857.5	857.5
n	137	155	176	176	193	215	257	257
n1	112	123	132	132	149	161	181	181
x	-	-	-	-	-	-	0.8	0.8

* "k1" Ölçüsü frenli redüktörlere aittir.
Dimension "k1" is for motors with brake.
Maße "k1" ist für Bremsenmotoren.

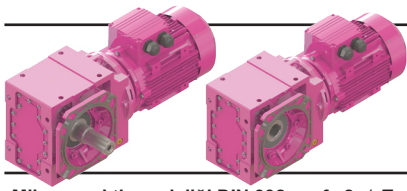

Ölçü Sayfaları Dimension Pages Abmessungsseiten

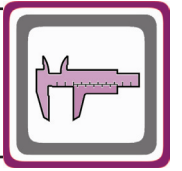

-Mil ucu çektirme deliği DIN 332 sayfa 2 / Tapped center hole to DIN 332, sheet 2 / Zentrierung mit Gewinde DIN 332, Blatt 2

KR373.02

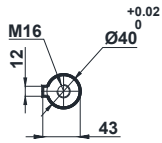
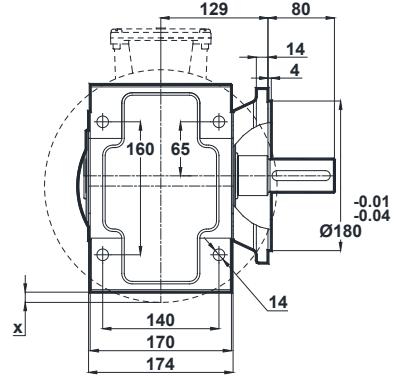
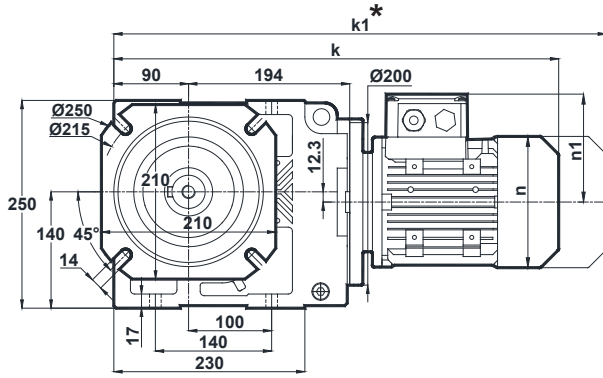

x: Motor ayak bağlantı yüzeyinin altında ise
x: If Motor is lower than foot mounting plane
x: Wenn der Motor unter der Fußmontageebene ist

Klemens Pozisyonları
Terminal Box Positions
Klemmenkasten Positionen

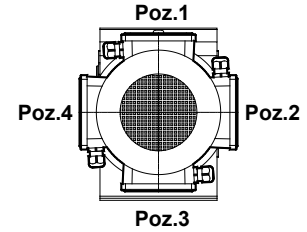

71-80-90-100-112-132

Tip / Type / Typ

Opsiyonel flanş ölçüleri için sayfa 587'ye bakınız.
Please see on page 587 for optional flange dimensions
Siehe Seite 587 für auswählbare Flanschabmessungen

	71	80	90S	90L	100L	112M	132S	132M
k	496	530	569	569	617	641	727.5	727.5
k1	587	623	672.5	672.5	725.5	745.5	857.5	857.5
n	137	155	176	176	193	215	257	257
n1	112	123	132	132	149	161	181	181
x	-	-	-	-	-	-	0.8	0.8

KR373.03

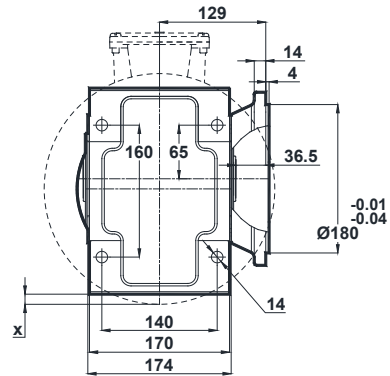
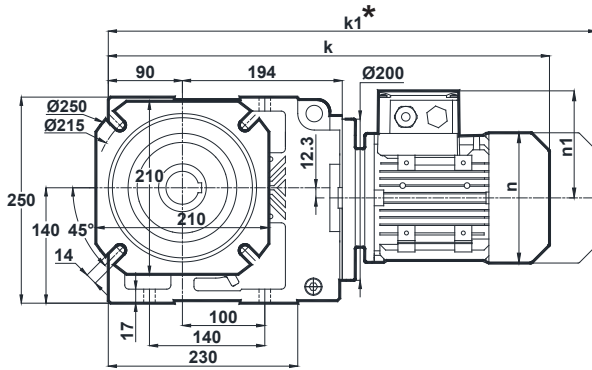

Std.

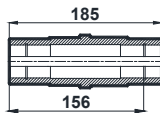

Ops.

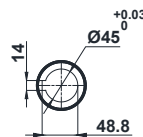

x: Motor ayak bağlantı yüzeyinin altında ise
x: If Motor is lower than foot mounting plane
x: Wenn der Motor unter der Fußmontageebene ist

	71	80	90S	90L	100L	112M	132S	132M
k	496	530	569	569	617	641	727.5	727.5
k1	587	623	672.5	672.5	725.5	745.5	857.5	857.5
n	137	155	176	176	193	215	257	257
n1	112	123	132	132	149	161	181	181
x	-	-	-	-	-	-	0.8	0.8

Opsiyonel flanş ölçüleri için sayfa 587'ye bakınız.
Please see on page 587 for optional flange dimensions
Siehe Seite 587 für auswählbare Flanschabmessungen

* "k1" Ölçüsü frenli redüktörlere aittir.
Dimension "k1" is for motors with brake.
Maße "k1" ist für Bremsenmotoren.

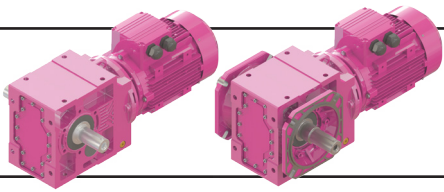

Ölçü Sayfaları Dimension Pages Abmessungsseiten

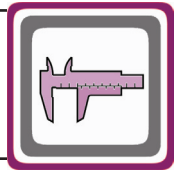

-Mil ucu çekirme deliği DIN 332 sayfa 2 / Tapped center hole to DIN 332, sheet 2 / Zentrierung mit Gewinde DIN 332, Blatt 2

KR373.04

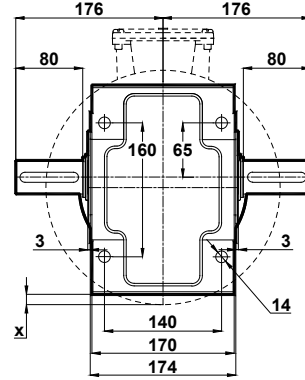
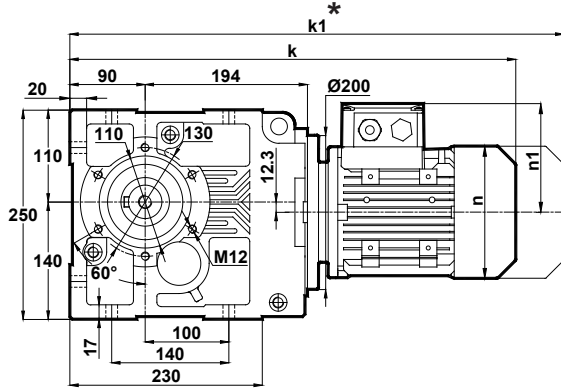

x: Motor Ayak bağlantı yüzeyinin altında ise
x: If Motor is lower than foot mounting plane
x: Wenn der Motor unter der Fußmontageebene ist

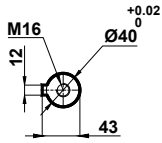

Klemens Pozisyonları
Terminal Box Positions
Klemmenkasten Positionen

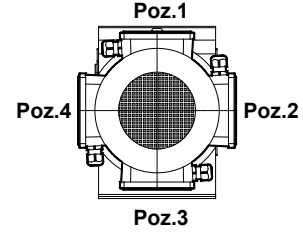

71-80-90-100-112-132
Tip / Type / Typ

	71	80	90S	90L	100L	112M	132S	132M
k	496	530	569	569	617	641	727.5	727.5
k1	587	623	672.5	672.5	725.5	745.5	857.5	857.5
n	137	155	176	176	193	215	257	257
n1	112	123	132	132	149	161	181	181
x	-	-	-	-	-	-	0.8	0.8

KR373.05

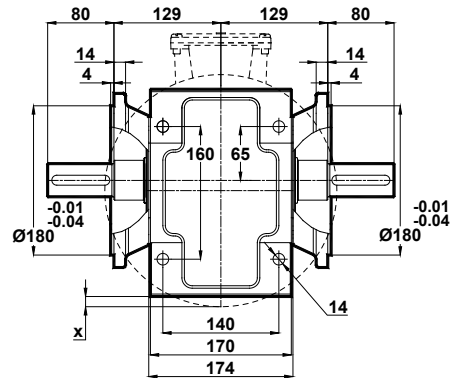
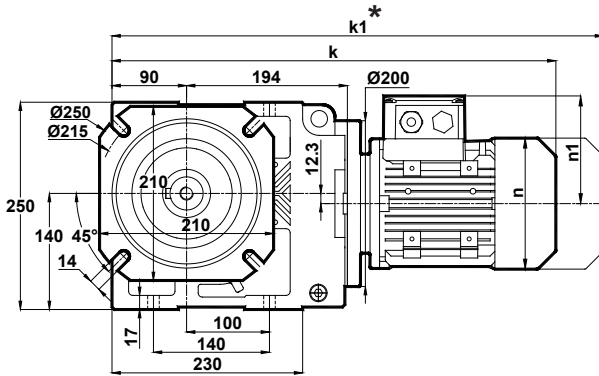

x: Motor Ayak bağlantı yüzeyinin altında ise
x: If Motor is lower than foot mounting plane
x: Wenn der Motor unter der Fußmontageebene ist

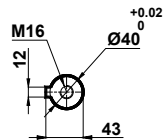

Opsiyonel flanş ölçüleri için sayfa 587'ye bakınız.
Please see on page 587 for optional flange dimensions
Siehe Seite 587 für auswählbare Flanschabmessungen

	71	80	90S	90L	100L	112M	132S	132M
k	496	530	569	569	617	641	727.5	727.5
k1	587	623	672.5	672.5	725.5	745.5	857.5	857.5
n	137	155	176	176	193	215	257	257
n1	112	123	132	132	149	161	181	181
x	-	-	-	-	-	-	0.8	0.8

* "k1" Ölçüsü frenli redüktörlere aittir.
Dimension "k1" is for motors with brake.
Maße "k1" ist für Bremsenmotoren.

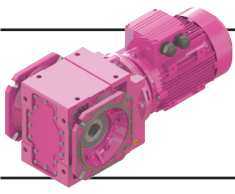

Ölçü Sayfaları Dimension Pages Abmessungsseiten

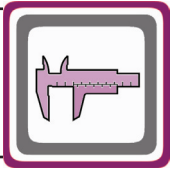

-Mil ucu çektirme deliği DIN 332 sayfa 2 / Tapped center hole to DIN 332, sheet 2 / Zentrierung mit Gewinde DIN 332, Blatt 2

KR373.08

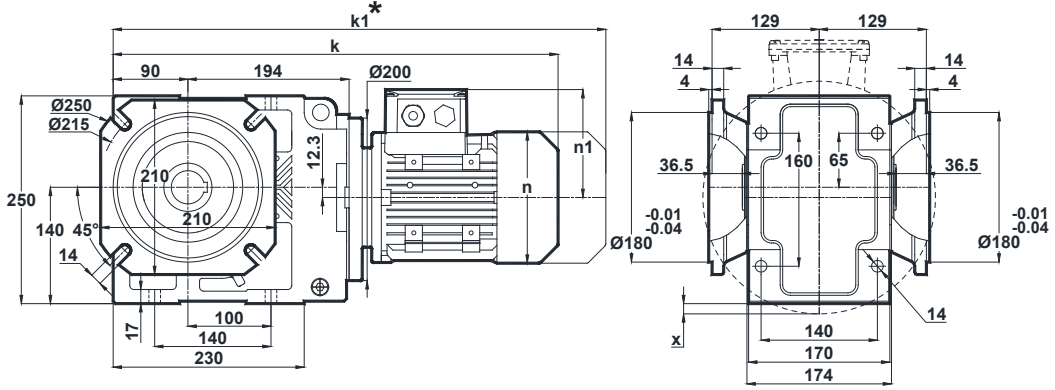

Std.

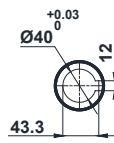

Ops.

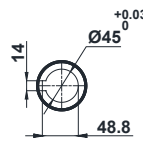

x: Motor Ayak bağlantı yüzeyinin altında ise
x: If Motor is lower than foot mounting plane
x: Wenn der Motor unter der Fußmontageebene ist

Klemens Pozisyonları
Terminal Box Positions
Klemmenkasten Positionen

Poz.1

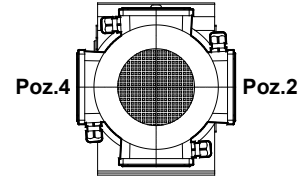

Poz.3

71-80-90-100-112-132
Tip / Type / Typ

	71	80	90S	90L	100L	112M	132S	132M
k	496	530	569	569	617	641	727.5	727.5
k1	587	623	672.5	672.5	725.5	745.5	857.5	857.5
n	137	155	176	176	193	215	257	257
n1	112	123	132	132	149	161	181	181
x	-	-	-	-	-	-	0.8	0.8

Opsiyonel flanş ölçüleri için sayfa 587'ye bakınız.
Please see on page 587 for optional flange dimensions
Siehe Seite 587 für auswählbare Flanschabmessungen

* " k1 " Ölçüsü frenli redüktörlere aittir.
Dimension " k1 " is for motors with brake.
Maße " k1 " ist für Bremsenmotoren.

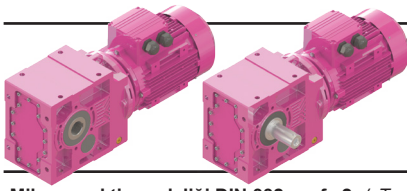

Ölçü Sayfaları

Dimension Pages

Abmessungsseiten

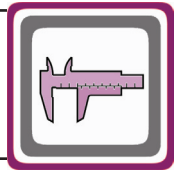

-Mil ucu çekirme deliği DIN 332 sayfa 2 / Tapped center hole to DIN 332, sheet 2 / Zentrierung mit Gewinde DIN 332, Blatt 2

KR374.00

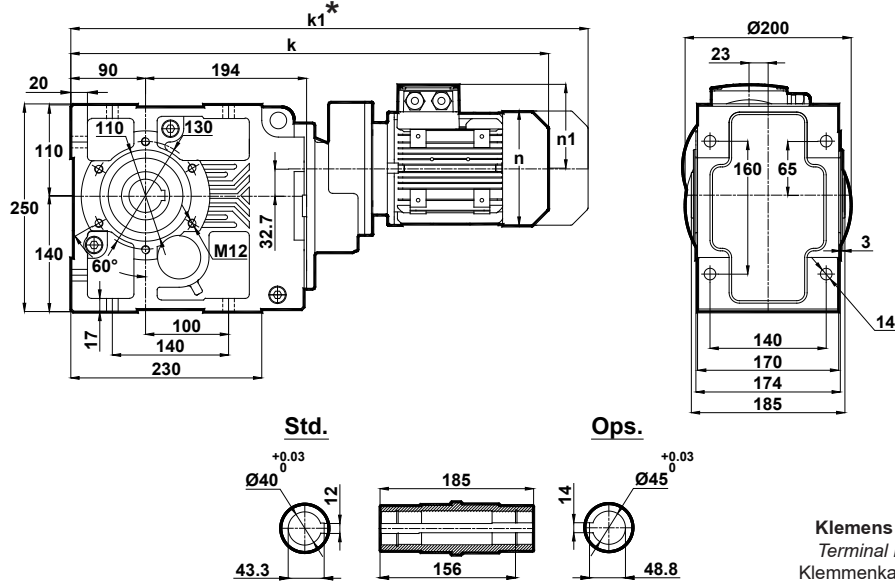

	63	71	80
k	548	575	609
k1	609	666	702
n	121	137	155
n1	97	112	123

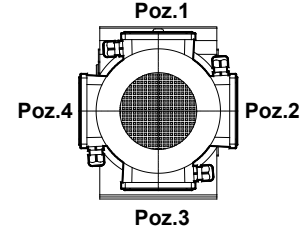

63-71-80
Tip / Type / Typ

KR374.01

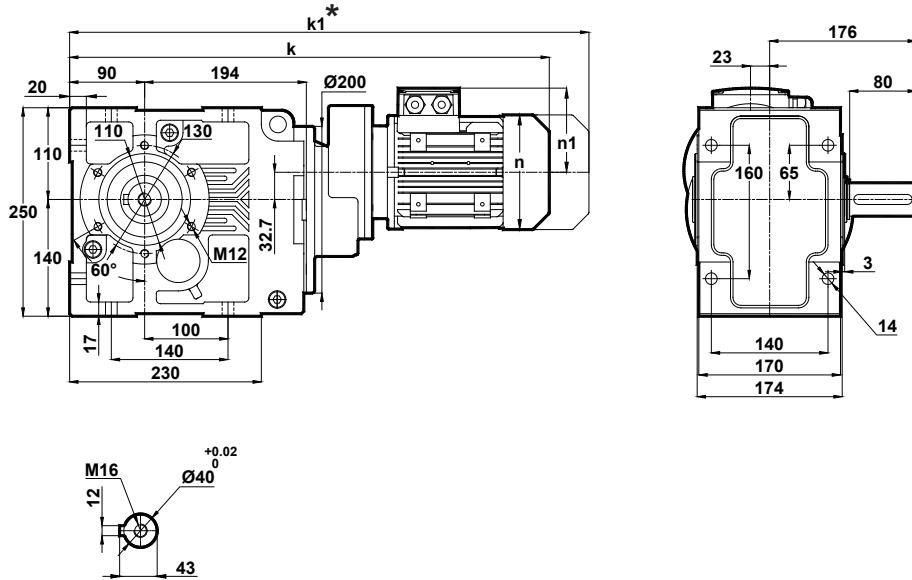

	63	71	80
k	548	575	609
k1	609	666	702
n	121	137	155
n1	97	112	123

* "k1" Ölçüsü frenli redüktörlere aittir.
Dimension "k1" is for motors with brake.
Maße "k1" ist für Bremsenmotoren.

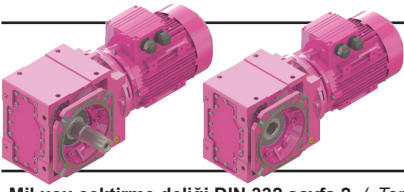

Ölçü Sayfaları

Dimension Pages

Abmessungsseiten

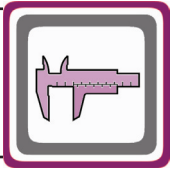

-Mil ucu çektirme deliği DIN 332 sayfa 2 / Tapped center hole to DIN 332, sheet 2 / Zentrierung mit Gewinde DIN 332, Blatt 2

KR374.02

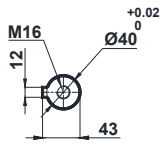
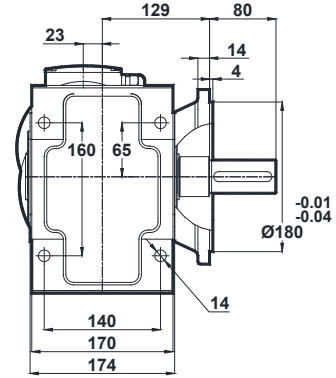
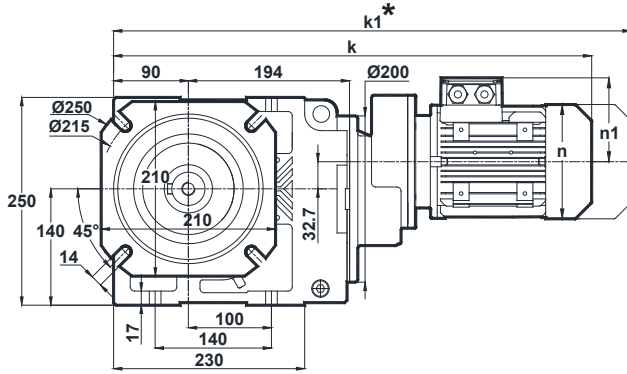

	63	71	80
k	548	575	609
k1	609	666	702
n	121	137	155
n1	97	112	123

Klemens Pozisyonları
Terminal Box Positions
Klemmenkasten Positionen

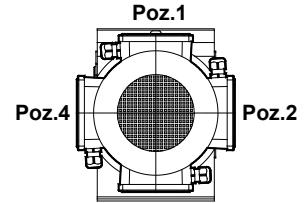

Poz.3

63-71-80
Tip / Type / Typ

Opsiyonel flanş ölçüleri için sayfa 587'ye bakınız.
Please see on page 587 for optional flange dimensions
Siehe Seite 587 für auswählbare Flanschabmessungen

KR374.03

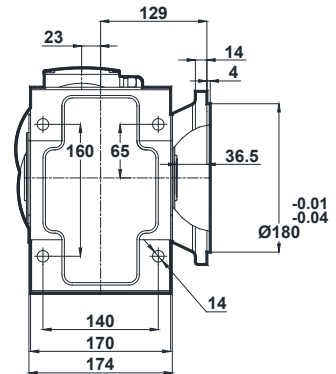
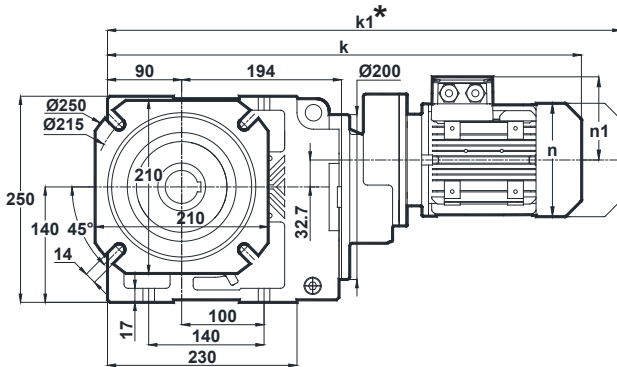

Std.



Ops.

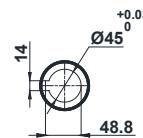

	63	71	80
k	548	575	609
k1	609	666	702
n	121	137	155
n1	97	112	123

Opsiyonel flanş ölçüleri için sayfa 587'ye bakınız.
Please see on page 587 for optional flange dimensions
Siehe Seite 587 für auswählbare Flanschabmessungen

* " k1 " Ölçüsü frenli redüktörlere aittir.
Dimension " k1 " is for motors with brake.
Maße " k1 " ist für Bremsenmotoren.

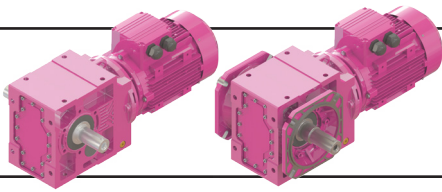

Ölçü Sayfaları

Dimension Pages

Abmessungsseiten

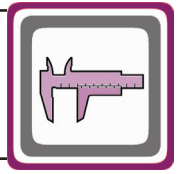

-Mil ucu çekirme deliği DIN 332 sayfa 2 / Tapped center hole to DIN 332, sheet 2 / Zentrierung mit Gewinde DIN 332, Blatt 2

KR374.04

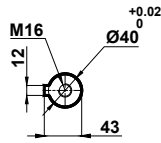
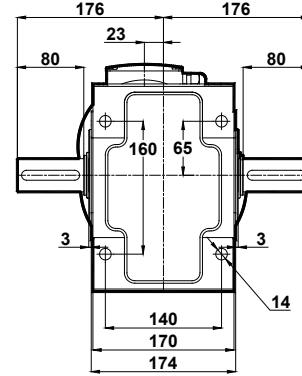
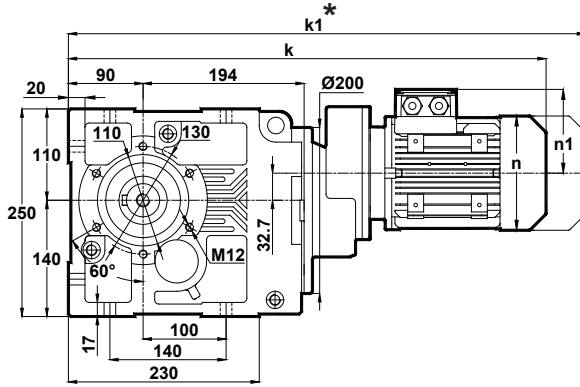

	63	71	80
k	548	575	609
k1	609	666	702
n	121	137	155
n1	97	112	123

Klemens Pozisyonları
Terminal Box Positions
Klemmenkasten Positionen

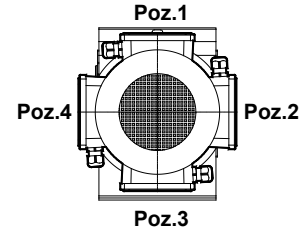

63-71-80
Tip / Type / Typ

KR374.05

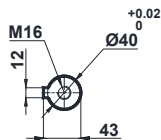
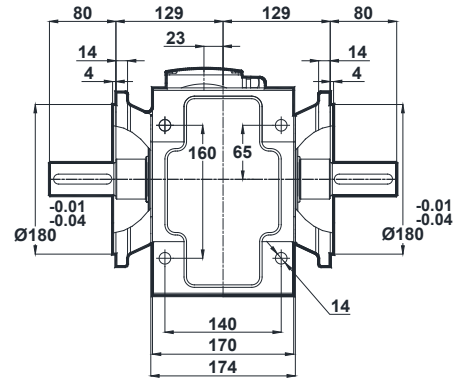
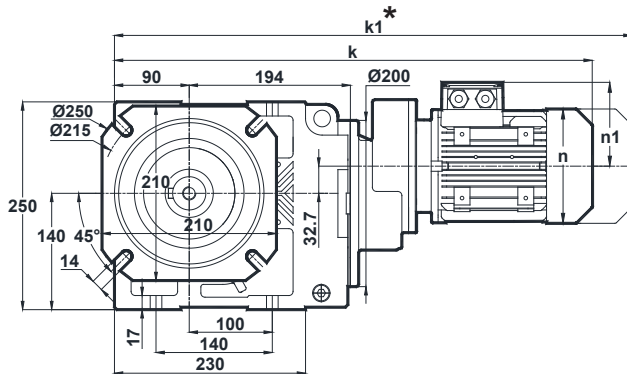

	63	71	80
k	548	575	609
k1	609	666	702
n	121	137	155
n1	97	112	123

Opsiyonel flanş ölçüleri için sayfa 587'ye bakınız.
Please see on page 587 for optional flange dimensions
Siehe Seite 587 für auswählbare Flanschabmessungen

* " k1 " Ölçüsü frenli redüktörlere aittir.
Dimension " k1 " is for motors with brake.
Maße " k1 " ist für Bremsenmotoren.

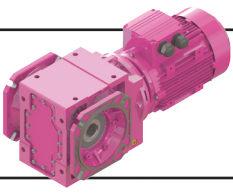

Ölçü Sayfaları Dimension Pages Abmessungsseiten

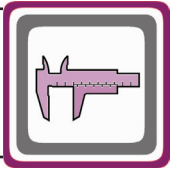

-Mil ucu çektirme deliği DIN 332 sayfa 2 / Tapped center hole to DIN 332, sheet 2 / Zentrierung mit Gewinde DIN 332, Blatt 2

KR374.08

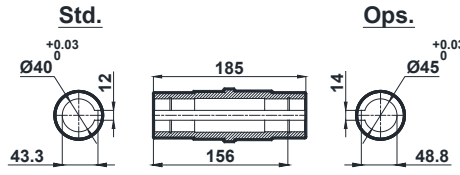
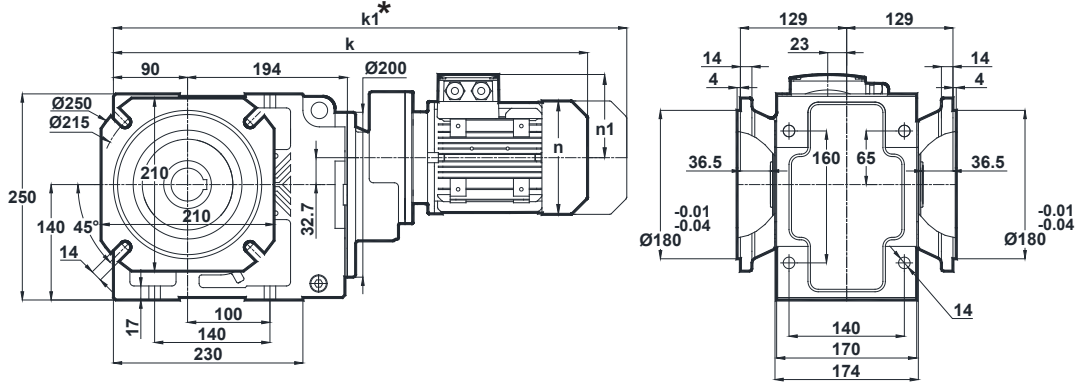

Klemens Pozisyonları
Terminal Box Positions
Klemmenkasten Positionen

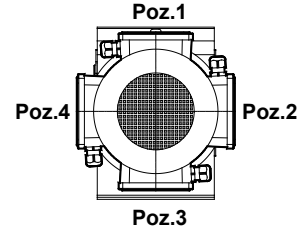

63-71-80
Tip / Type / Typ

	63	71	80
k	548	575	609
k1	609	666	702
n	121	137	155
n1	97	112	123

Opsiyonel flanş ölçüleri için sayfa 587'ye bakınız.
Please see on page 587 for optional flange dimensions
Siehe Seite 587 für auswählbare Flanschabmessungen

* "k1" Ölçüsü frenli redüktörlere aittir.
Dimension "k1" is for motors with brake.
Maße "k1" ist für Bremsenmotoren.

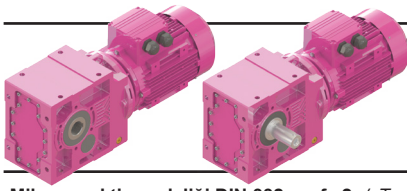

Ölçü Sayfaları

Dimension Pages

Abmessungsseiten

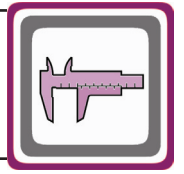

-Mil ucu çektirme deliği DIN 332 sayfa 2 / Tapped center hole to DIN 332, sheet 2 / Zentrierung mit Gewinde DIN 332, Blatt 2

KR375.00
KR376.00

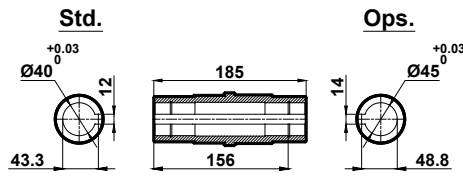
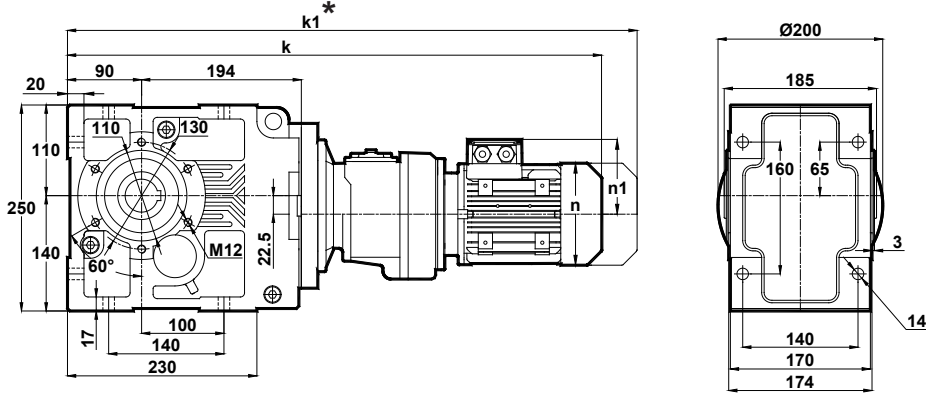

Klemens Pozisyonları
Terminal Box Positions
Klemmenkasten Positionen

	63	71
k	652.5	678.5
k1	713.5	769.5
n	121	137
n1	97	112

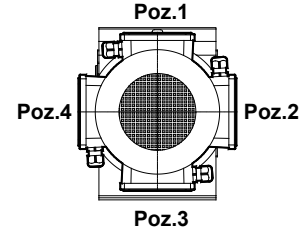

63-71
Tip / Type / Typ

KR375.01
KR376.01

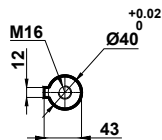
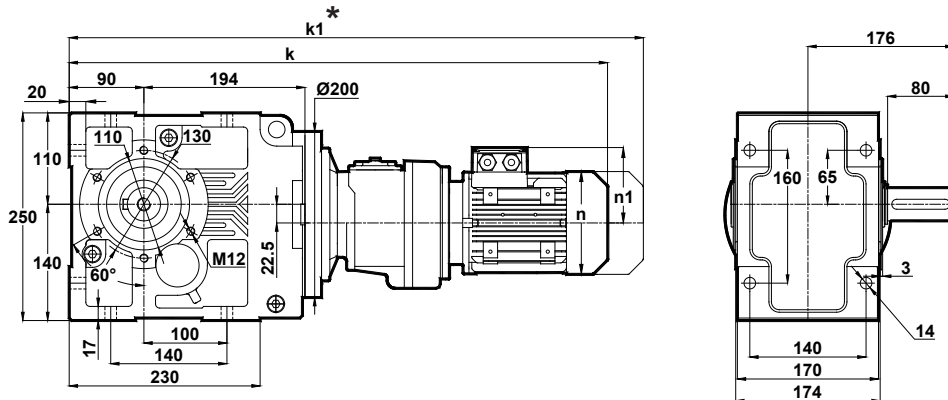

	63	71
k	652.5	678.5
k1	713.5	769.5
n	121	137
n1	97	112

* "k1" Ölçüsü frenli redüktörlere aittir.
Dimension "k1" is for motors with brake.
Maße "k1" ist für Bremsenmotoren.

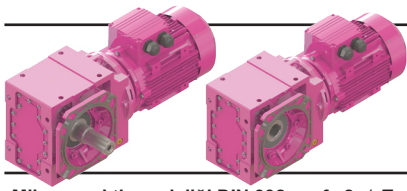

Ölçü Sayfaları Dimension Pages Abmessungenseiten

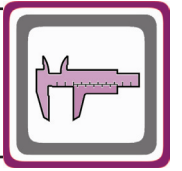

-Mil ucu çektirme deliği DIN 332 sayfa 2 / Tapped center hole to DIN 332, sheet 2 / Zentrierung mit Gewinde DIN 332, Blatt 2

KR375.02
KR376.02

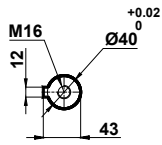
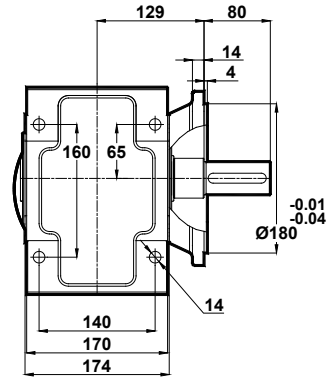
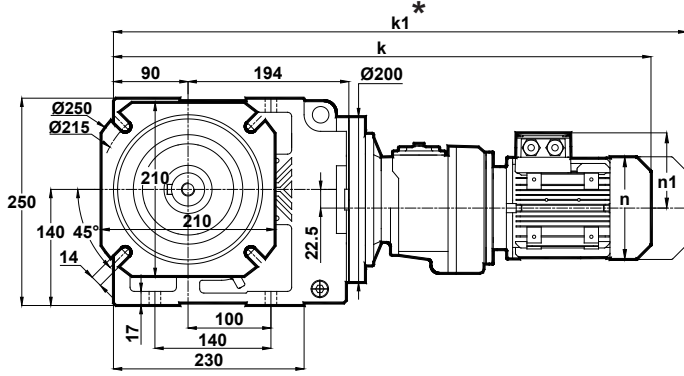

	63	71
k	652.5	678.5
k1	713.5	769.5
n	121	137
n1	97	112

Klemens Pozisyonları
Terminal Box Positions
Klemmenkasten Positionen

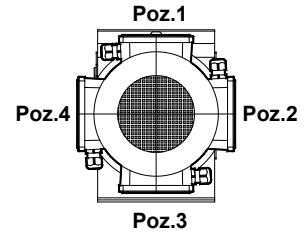

63-71
Tip / Type / Typ

Opsiyonel flanş ölçüleri için sayfa 587'ye bakınız.
Please see on page 587 for optional flange dimensions
Siehe Seite 587 für auswählbare Flanschabmessungen

KR375.03
KR376.03

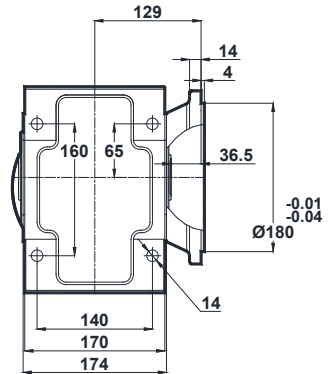
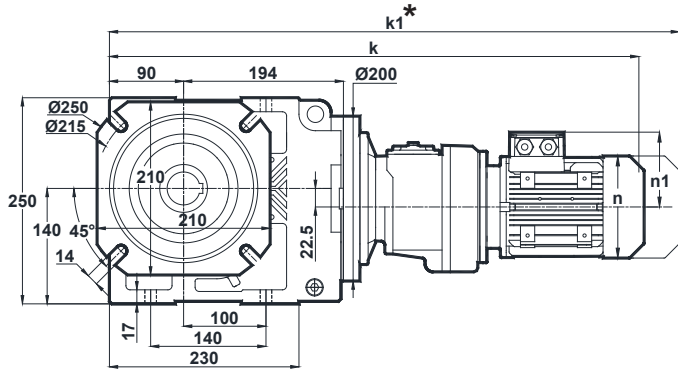

Std.

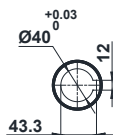

Ops.

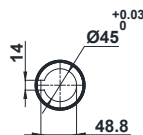
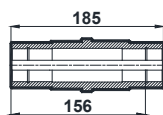

	63	71
k	652.5	678.5
k1	713.5	769.5
n	121	137
n1	97	112

Opsiyonel flanş ölçüleri için sayfa 587'ye bakınız.
Please see on page 587 for optional flange dimensions
Siehe Seite 587 für auswählbare Flanschabmessungen

* " k1 " Ölçüsü frenli redüktörlere aittir.
Dimension " k1 " is for motors with brake.
Maße " k1 " ist für Bremsenmotoren.

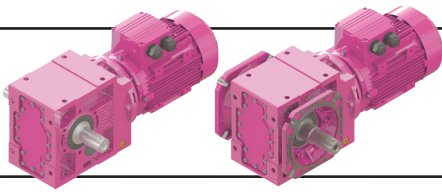

Ölçü Sayfaları

Dimension Pages

Abmessungsseiten

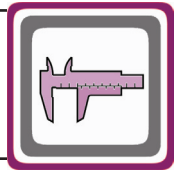

-Mil ucu çektirme deliği DIN 332 sayfa 2 / Tapped center hole to DIN 332, sheet 2 / Zentrierung mit Gewinde DIN 332, Blatt 2

KR375.04
KR376.04

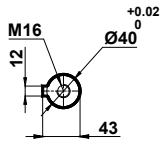
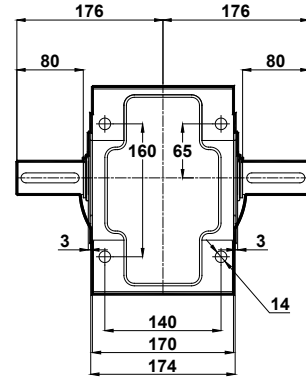
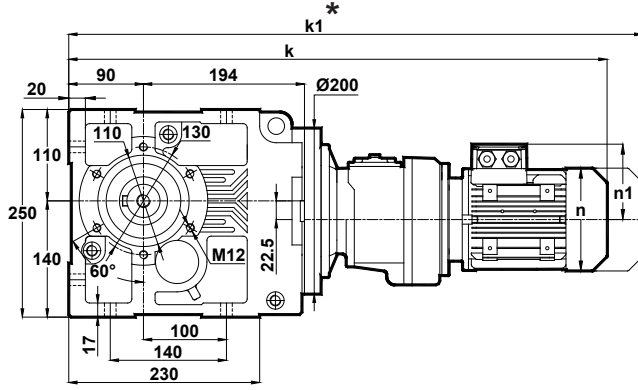

	63	71
k	652.5	678.5
k1	713.5	769.5
n	121	137
n1	97	112

Klemens Pozisyonları
Terminal Box Positions
Klemmenkasten Positionen

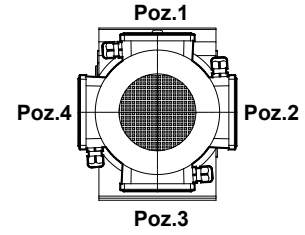

63-71
Tip / Type / Typ

KR375.05
KR376.05

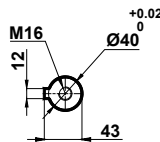
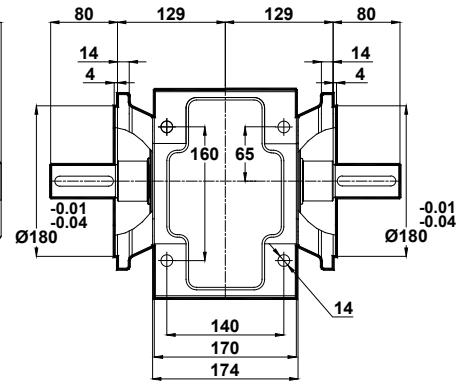
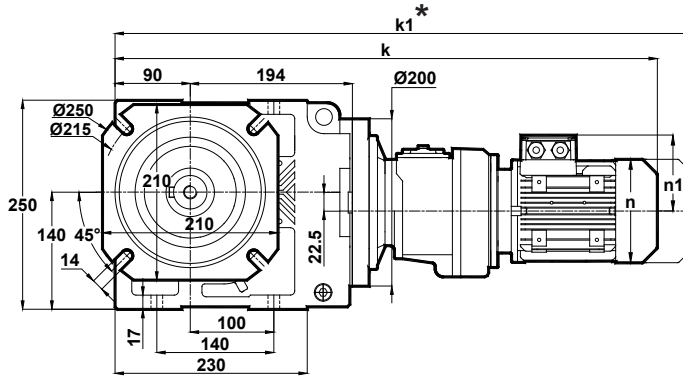

	63	71
k	652.5	678.5
k1	713.5	769.5
n	121	137
n1	97	112

Opsiyonel flanş ölçüleri için sayfa 587'ye bakınız.
Please see on page 587 for optional flange dimensions
Siehe Seite 587 für auswählbare Flanschabmessungen

* "k1" Ölçüsü frenli redüktörlere aittir.
Dimension "k1" is for motors with brake.
Maße "k1" ist für Bremsenmotoren.

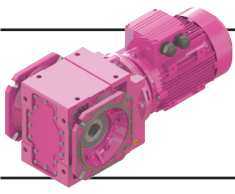

Ölçü Sayfaları Dimension Pages Abmessungsseiten

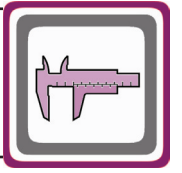

-Mil ucu çektirme deliği DIN 332 sayfa 2 / Tapped center hole to DIN 332, sheet 2 / Zentrierung mit Gewinde DIN 332, Blatt 2

KR375.08
KR376.08

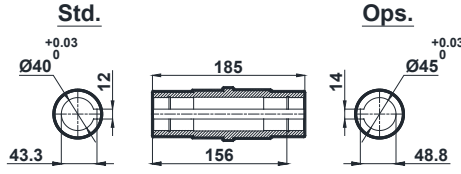
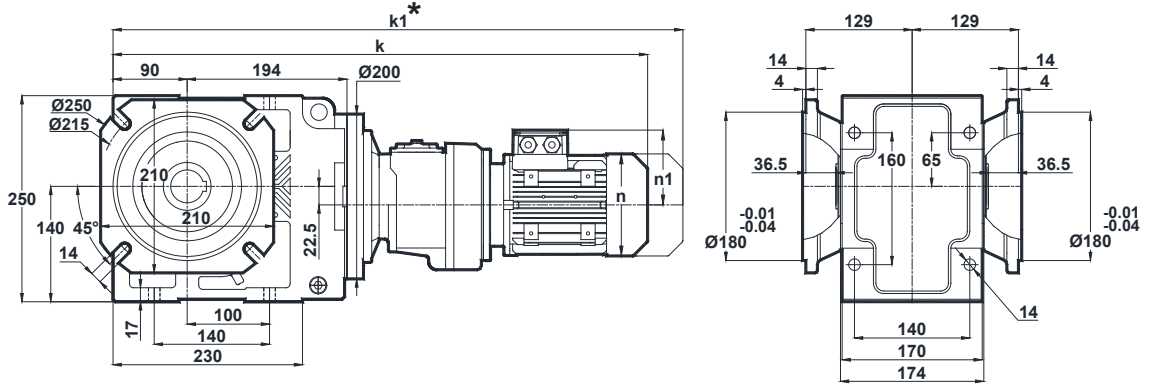

Klemens Pozisyonları
Terminal Box Positions
Klemmenkasten Positionen

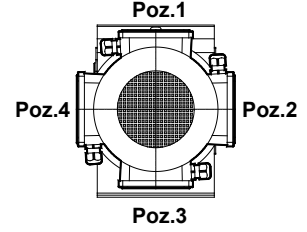

63-71
Tip / Type / Typ

	63	71
k	652.5	678.5
k1	713.5	769.5
n	121	137
n1	97	112

Opsiyonel flanş ölçüleri için sayfa 587'ye bakınız.
Please see on page 587 for optional flange dimensions
Siehe Seite 587 für auswählbare Flanschabmessungen

* " k1 " Ölçüsü frenli redüktörlere aittir.
Dimension " k1 " is for motors with brake.
Maße " k1 " ist für Bremsenmotoren.

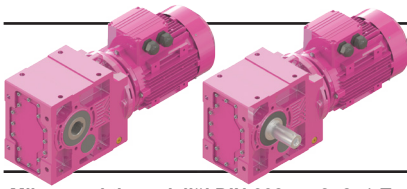

Ölçü Sayfaları

Dimension Pages

Abmessungsseiten

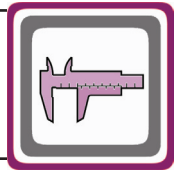

-Mil ucu çektirme deliği DIN 332 sayfa 2 / Tapped center hole to DIN 332, sheet 2 / Zentrierung mit Gewinde DIN 332, Blatt 2

KR473.00

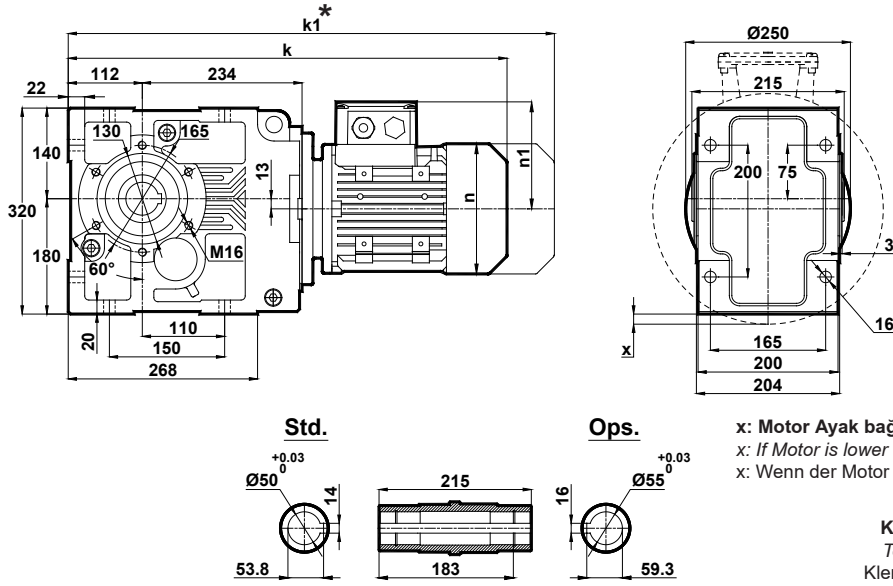

x: Motor Ayak bağlantı yüzeyinin altında ise
x: If Motor is lower than foot mounting plane
x: Wenn der Motor unter der Fußmontageebene ist

Klemens Pozisyonları
Terminal Box Positions
Klemmenkasten Positionen

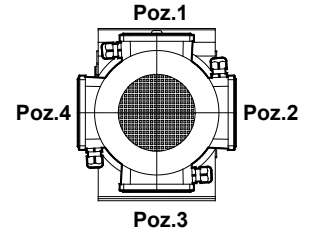

80-90-100-112-132-160-180
Tip / Type / Typ

	80	90S	90L	100L	112M	132S	132M	160M	160L	180M	180L
k	586.5	625.5	625.5	670.5	694.5	779.5	779.5	875.5	875.5	947.5	947.5
k1	679.5	729	729	779	799	909.5	909.5	1023.5	1023.5	1106	1106
n	155	176	176	193	215	257	257	316	316	348	348
n1	123	132	132	149	161	181	181	224	224	250	250
x	-	-	-	-	-	-	-	-	-	6.5	6.5

KR473.01

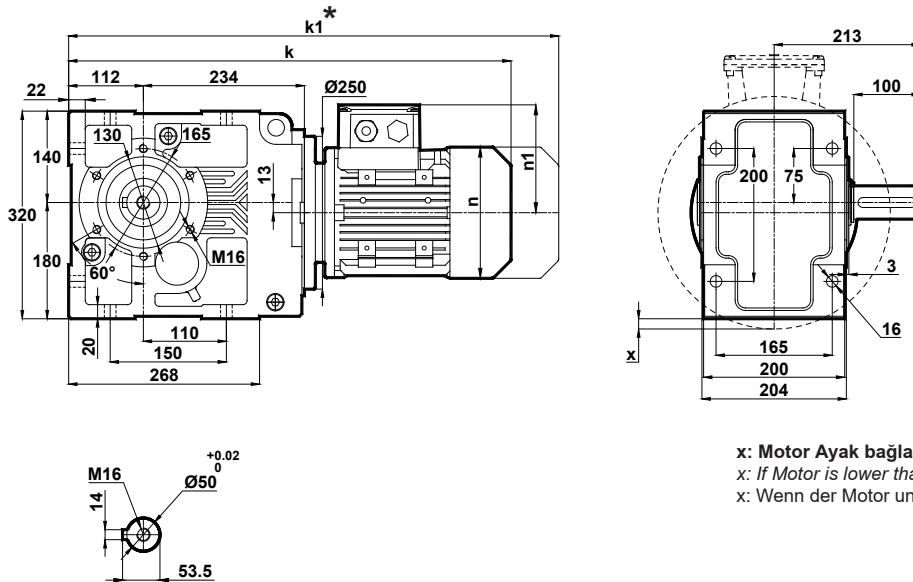

x: Motor Ayak bağlantı yüzeyinin altında ise
x: If Motor is lower than foot mounting plane
x: Wenn der Motor unter der Fußmontageebene ist

	80	90S	90L	100L	112M	132S	132M	160M	160L	180M	180L
k	586.5	625.5	625.5	670.5	694.5	779.5	779.5	875.5	875.5	947.5	947.5
k1	679.5	729	729	779	799	909.5	909.5	1023.5	1023.5	1106	1106
n	155	176	176	193	215	257	257	316	316	348	348
n1	123	132	132	149	161	181	181	224	224	250	250
x	-	-	-	-	-	-	-	-	-	6.5	6.5

* "k1" Ölçüsü frenli redüktörlere aittir.
Dimension "k1" is for motors with brake.
Maße "k1" ist für Bremsenmotoren.

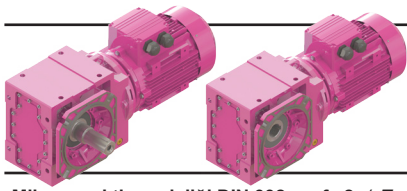

Ölçü Sayfaları Dimension Pages Abmessungsseiten

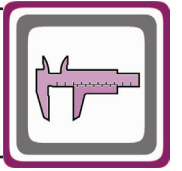

-Mil ucu çektirme deliği DIN 332 sayfa 2 / Tapped center hole to DIN 332, sheet 2 / Zentrierung mit Gewinde DIN 332, Blatt 2

KR473.02

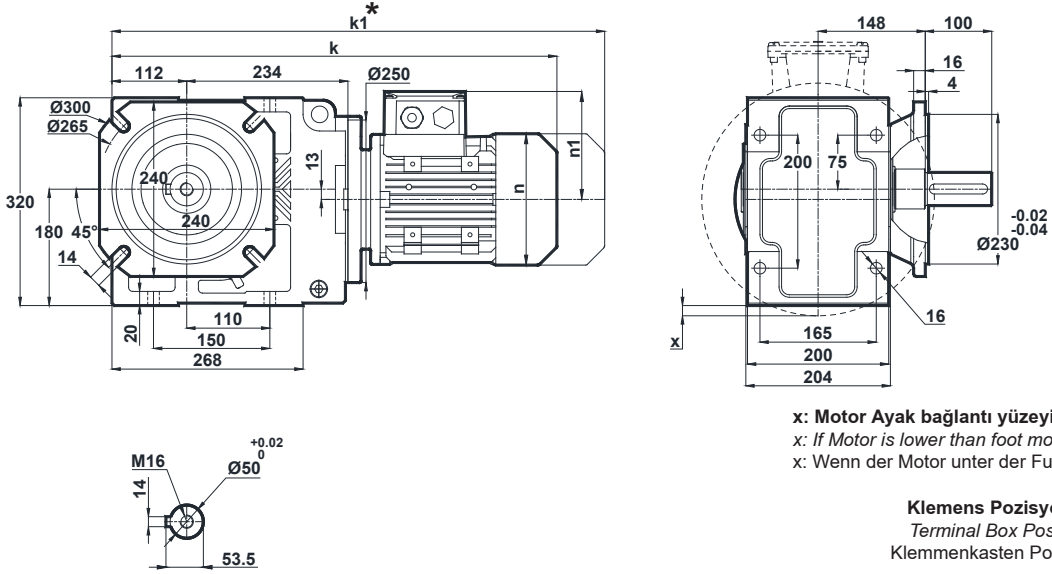

	80	90S	90L	100L	112M	132S	132M	160M	160L	180M	180L
k	586.5	625.5	625.5	670.5	694.5	779.5	779.5	875.5	875.5	947.5	947.5
k1	679.5	729	729	779	799	909.5	909.5	1023.5	1023.5	1106	1106
n	155	176	176	193	215	257	257	316	316	348	348
n1	123	132	132	149	161	181	181	224	224	250	250
x	-	-	-	-	-	-	-	-	-	6.5	6.5

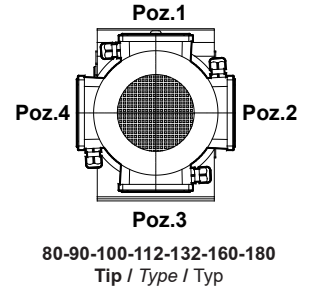

Opsiyonel flanş ölçüleri için sayfa 587'ye bakınız.
Please see on page 587 for optional flange dimensions
Siehe Seite 587 für auswählbare Flanschabmessungen

KR473.03

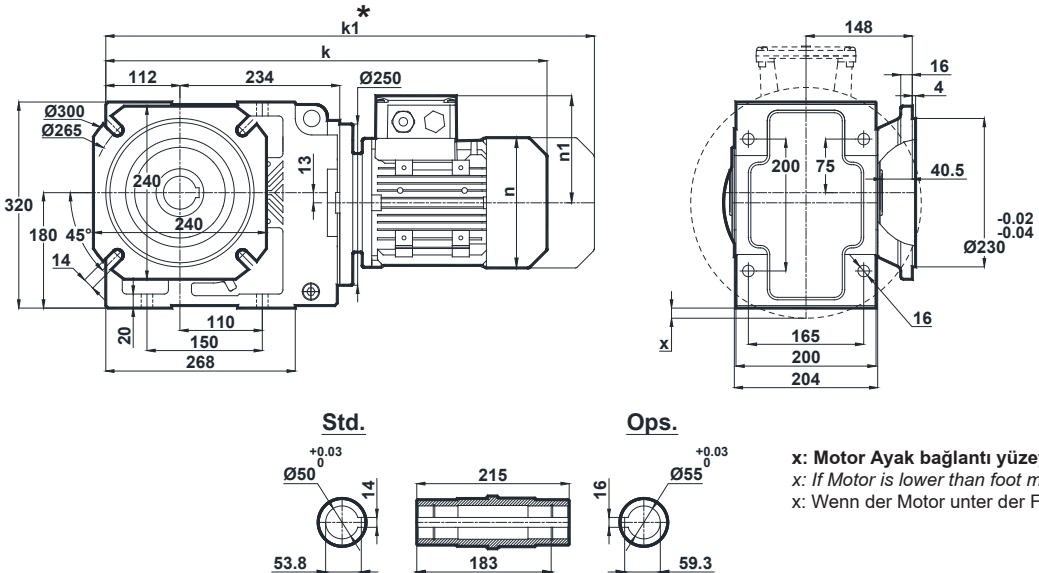

	80	90S	90L	100L	112M	132S	132M	160M	160L	180M	180L
k	586.5	625.5	625.5	670.5	694.5	779.5	779.5	875.5	875.5	947.5	947.5
k1	679.5	729	729	779	799	909.5	909.5	1023.5	1023.5	1106	1106
n	155	176	176	193	215	257	257	316	316	348	348
n1	123	132	132	149	161	181	181	224	224	250	250
x	-	-	-	-	-	-	-	-	-	6.5	6.5

Opsiyonel flanş ölçüleri için sayfa 587'ye bakınız.
Please see on page 587 for optional flange dimensions
Siehe Seite 587 für auswählbare Flanschabmessungen

* "k1" Ölçüsü frenli redüktörlere aittir.
Dimension "k1" is for motors with brake.
Maße "k1" ist für Bremsenmotoren.

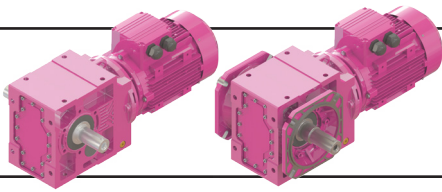

Ölçü Sayfaları Dimension Pages Abmessungsseiten

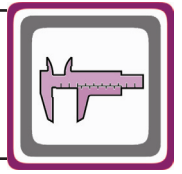

-Mil ucu çektirme deliği DIN 332 sayfa 2 / Tapped center hole to DIN 332, sheet 2 / Zentrierung mit Gewinde DIN 332, Blatt 2

KR473.04

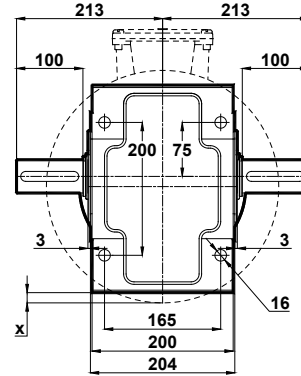
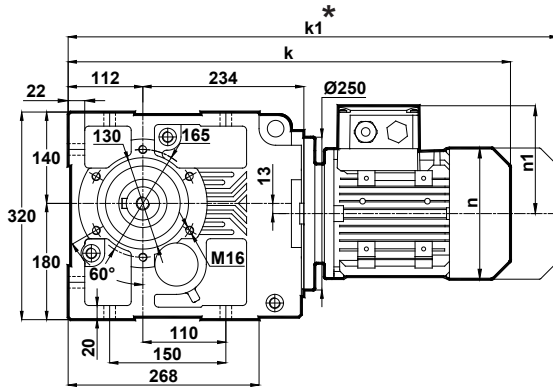

x: Motor Ayak bağlantı yüzeyinin altında ise
x: If Motor is lower than foot mounting plane
x: Wenn der Motor unter der Fußmontageebene ist

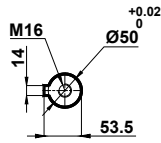

Klemens Pozisyonları
Terminal Box Positions
Klemmenkasten Positionen

	80	90S	90L	100L	112M	132S	132M	160M	160L	180M	180L
k	586.5	625.5	625.5	670.5	694.5	779.5	779.5	875.5	875.5	947.5	947.5
k1	679.5	729	729	779	799	909.5	909.5	1023.5	1023.5	1106	1106
n	155	176	176	193	215	257	257	316	316	348	348
n1	123	132	132	149	161	181	181	224	224	250	250
x	-	-	-	-	-	-	-	-	-	6.5	6.5

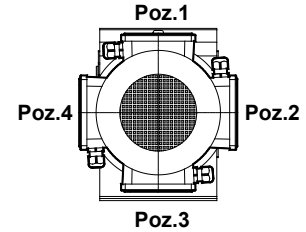

80-90-100-112-132-160-180
Tip / Type / Typ

KR473.05

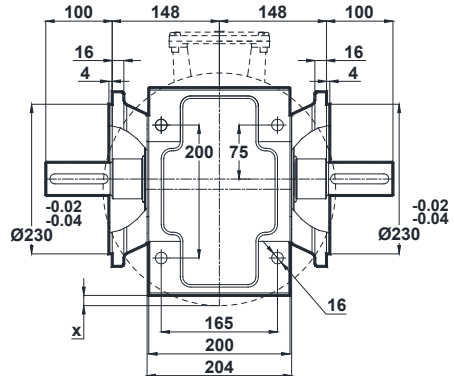
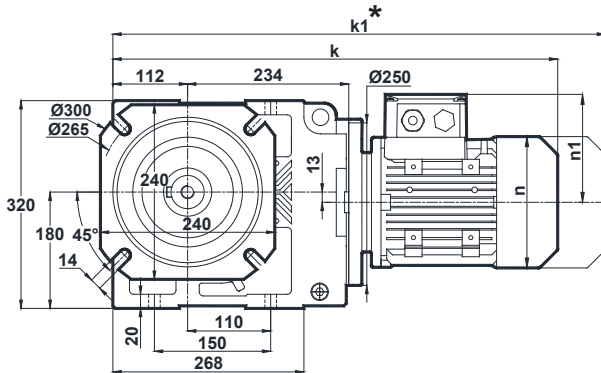

x: Motor Ayak bağlantı yüzeyinin altında ise
x: If Motor is lower than foot mounting plane
x: Wenn der Motor unter der Fußmontageebene ist

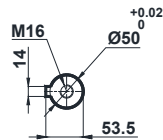

Opsiyonel flanş ölçüleri için sayfa 587'ye bakınız.
Please see on page 587 for optional flange dimensions
Siehe Seite 587 für auswählbare Flanschabmessungen

	80	90S	90L	100L	112M	132S	132M	160M	160L	180M	180L
k	586.5	625.5	625.5	670.5	694.5	779.5	779.5	875.5	875.5	947.5	947.5
k1	679.5	729	729	779	799	909.5	909.5	1023.5	1023.5	1106	1106
n	155	176	176	193	215	257	257	316	316	348	348
n1	123	132	132	149	161	181	181	224	224	250	250
x	-	-	-	-	-	-	-	-	-	6.5	6.5

* "k1" Ölçüsü frenli redüktörlere aittir.
Dimension "k1" is for motors with brake.
Maße "k1" ist für Bremsenmotoren.

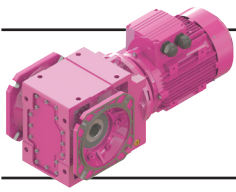

Ölçü Sayfaları

Dimension Pages

Abmessungenseiten

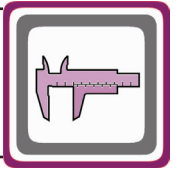

-Mil ucu çektirme deliği DIN 332 sayfa 2 / Tapped center hole to DIN 332, sheet 2 / Zentrierung mit Gewinde DIN 332, Blatt 2

KR473.08

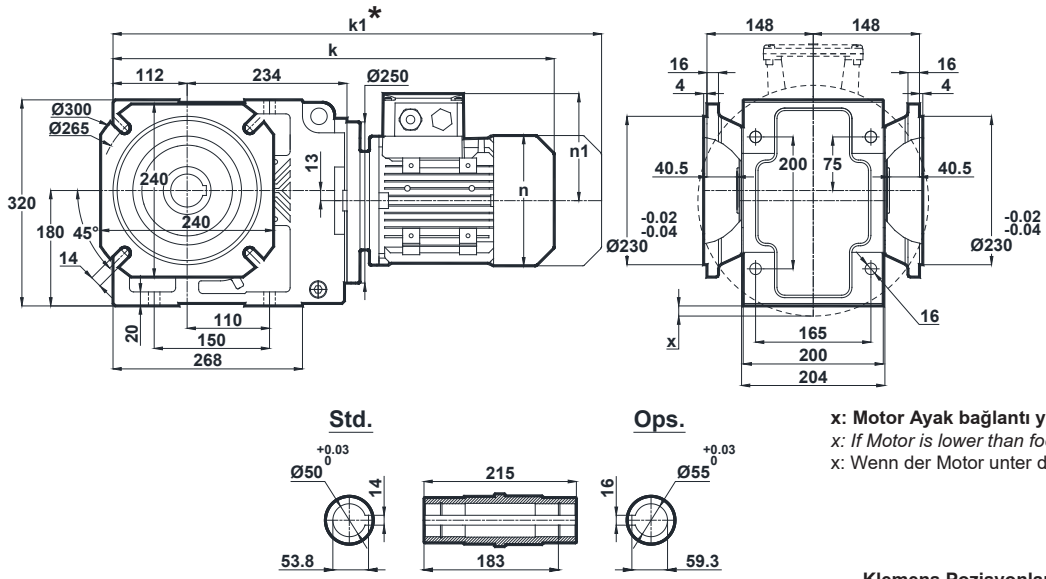

x: Motor Ayak bağlantı yüzeyinin altında ise
x: If Motor is lower than foot mounting plane
x: Wenn der Motor unter der Fußmontageebene ist

	80	90S	90L	100L	112M	132S	132M	160M	160L	180M	180L
k	586.5	625.5	625.5	670.5	694.5	779.5	779.5	875.5	875.5	947.5	947.5
k1	679.5	729	729	779	799	909.5	909.5	1023.5	1023.5	1106	1106
n	155	176	176	193	215	257	257	316	316	348	348
n1	123	132	132	149	161	181	181	224	224	250	250
x	-	-	-	-	-	-	-	-	-	6.5	6.5

Klemens Pozisyonları
Terminal Box Positions
Klemmenkasten Positionen

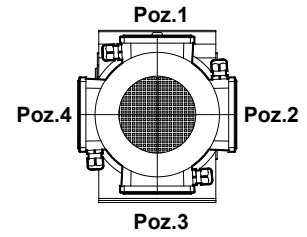

80-90-100-112-132-160-180
Tip / Type / Typ

Opsiyonel flanş ölçüleri için sayfa 587'ye bakınız.
Please see on page 587 for optional flange dimensions
Siehe Seite 587 für auswählbare Flanschabmessungen

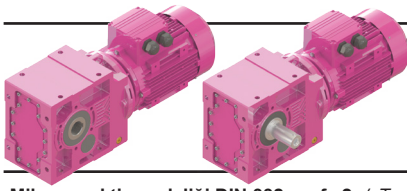

Ölçü Sayfaları

Dimension Pages

Abmessungsseiten

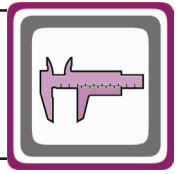

-Mil ucu çekirme deliği DIN 332 sayfa 2 / Tapped center hole to DIN 332, sheet 2 / Zentrierung mit Gewinde DIN 332, Blatt 2

KR474.00

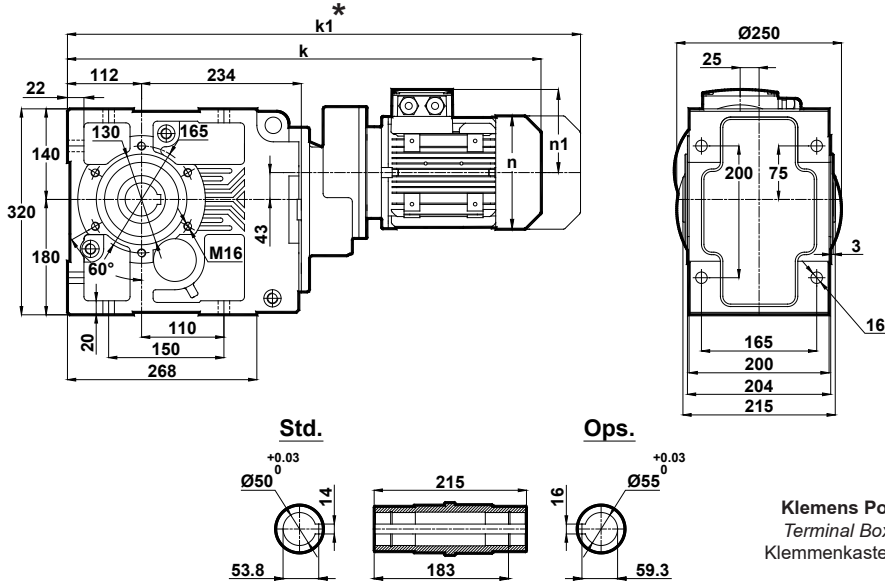

Klemens Pozisyonları
Terminal Box Positions
Klemmenkasten Positionen

	71	80
k	646	680
k1	737	773
n	137	155
n1	112	123

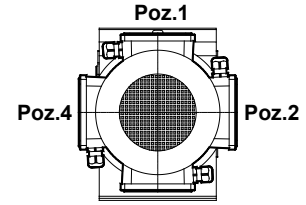

Poz.3
71-80
Tip / Type / Typ

KR474.01

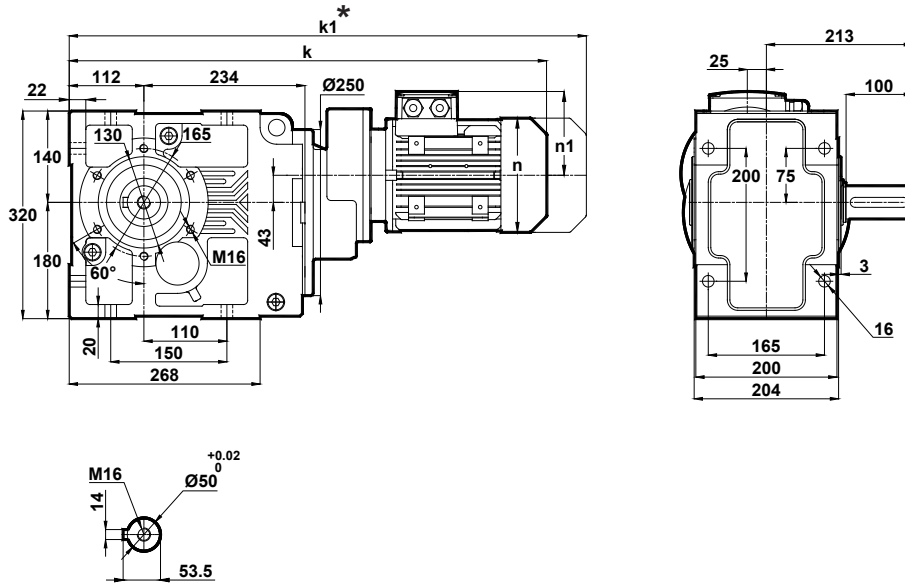

	71	80
k	646	680
k1	737	773
n	137	155
n1	112	123

* "k1" Ölçüsü frenli redüktörlere aittir.
Dimension "k1" is for motors with brake.
Maße "k1" ist für Bremsenmotoren.

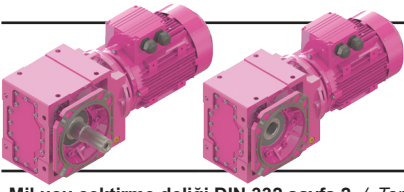

Ölçü Sayfaları Dimension Pages Abmessungsseiten

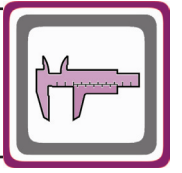

-Mil ucu çektirme deliği DIN 332 sayfa 2 / Tapped center hole to DIN 332, sheet 2 / Zentrierung mit Gewinde DIN 332, Blatt 2

KR474.02

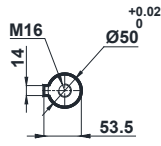
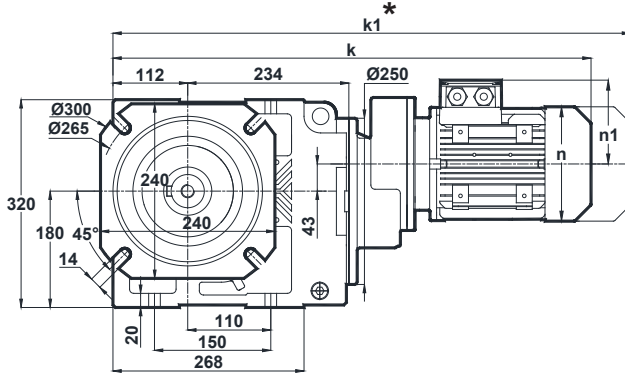

	71	80
k	646	680
k1	737	773
n	137	155
n1	112	123

Klemens Pozisyonları
Terminal Box Positions
Klemmenkasten Positionen

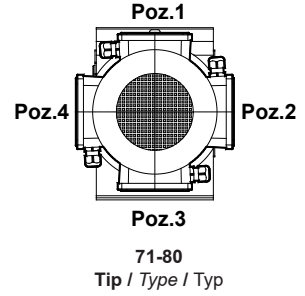

Opsiyonel flanş ölçüleri için sayfa 587'ye bakınız.
Please see on page 587 for optional flange dimensions
Siehe Seite 587 für auswählbare Flanschabmessungen

KR474.03

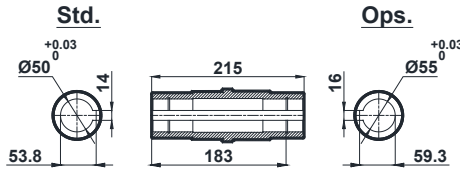
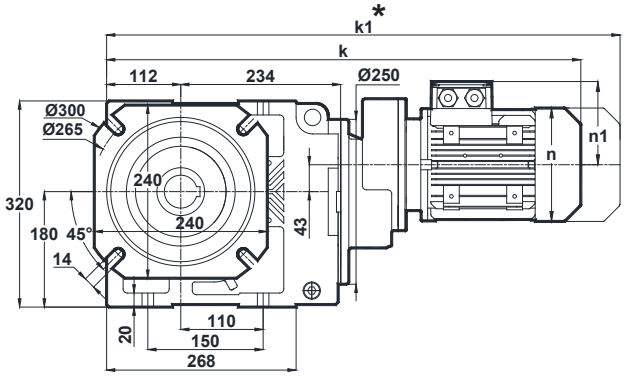

	71	80
k	646	680
k1	737	773
n	137	155
n1	112	123

Opsiyonel flanş ölçüleri için sayfa 587'ye bakınız.
Please see on page 587 for optional flange dimensions
Siehe Seite 587 für auswählbare Flanschabmessungen

* "k1" Ölçüsü frenli redüktörlere aittir.
Dimension "k1" is for motors with brake.
Maße "k1" ist für Bremsenmotoren.

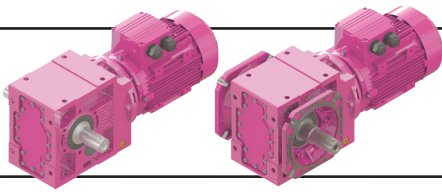

Ölçü Sayfaları

Dimension Pages

Abmessungsseiten

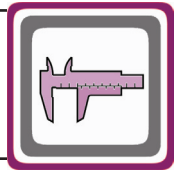

-Mil ucu çektirme deliği DIN 332 sayfa 2 / Tapped center hole to DIN 332, sheet 2 / Zentrierung mit Gewinde DIN 332, Blatt 2

KR474.04

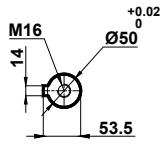
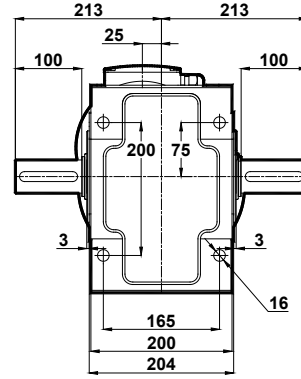
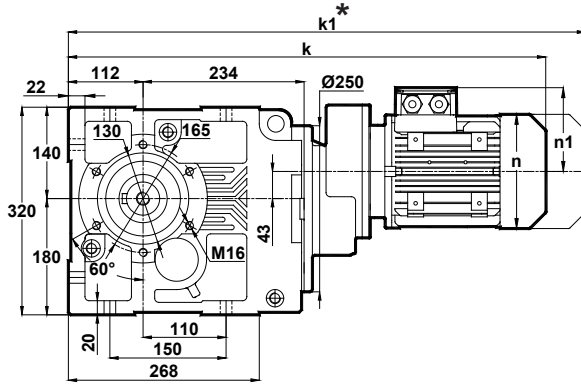

	71	80
k	646	680
k1	737	773
n	137	155
n1	112	123

Klemens Pozisyonları
Terminal Box Positions
Klemmenkasten Positionen

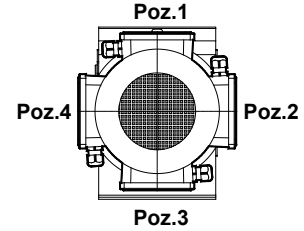

71-80
Tip / Type / Typ

KR474.05

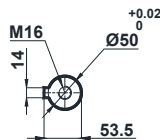
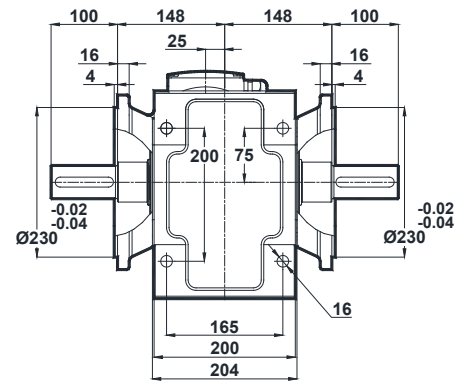
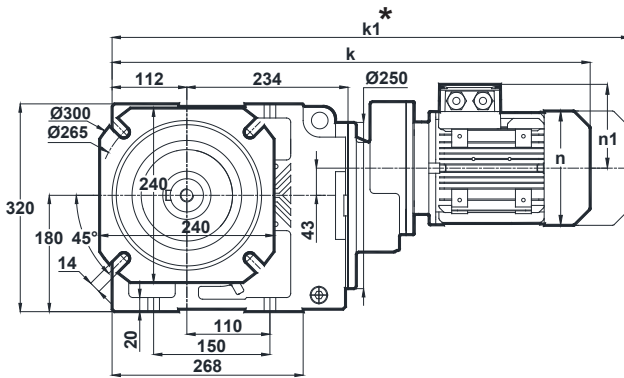

	71	80
k	646	680
k1	737	773
n	137	155
n1	112	123

Opsiyonel flanş ölçüleri için sayfa 587'ye bakınız.
Please see on page 587 for optional flange dimensions
Siehe Seite 587 für auswählbare Flanschabmessungen

* "k1" Ölçüsü frenli redüktörlere aittir.
Dimension "k1" is for motors with brake.
Maße "k1" ist für Bremsenmotoren.

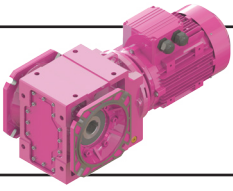

Ölçü Sayfaları Dimension Pages Abmessungsseiten

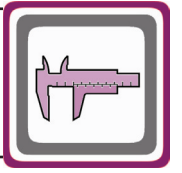

-Mil ucu çektirme deliği DIN 332 sayfa 2 / Tapped center hole to DIN 332, sheet 2 / Zentrierung mit Gewinde DIN 332, Blatt 2

KR474.08

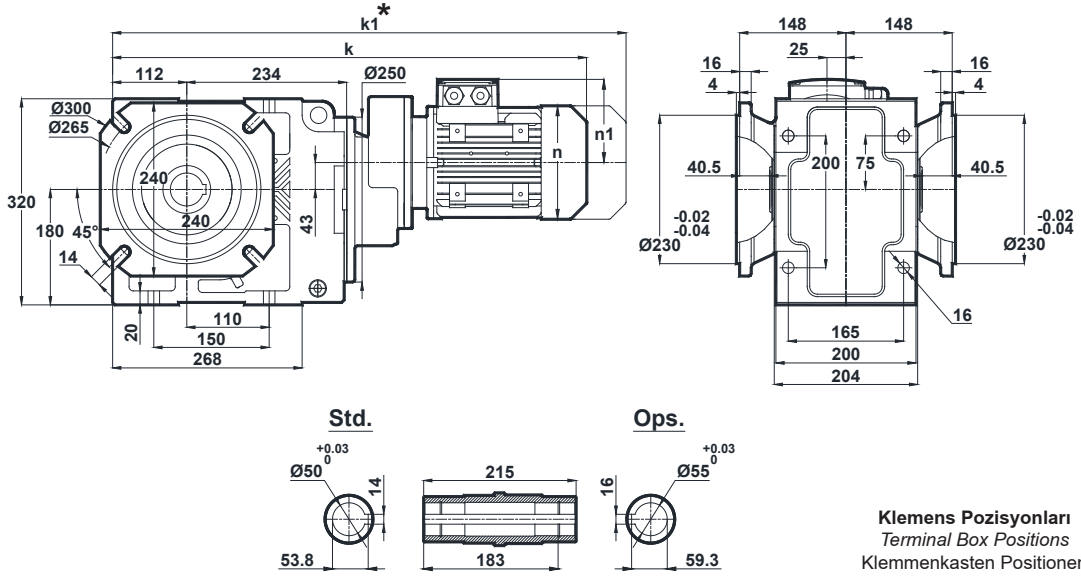

	71	80
k	646	680
k1	737	773
n	137	155
n1	112	123

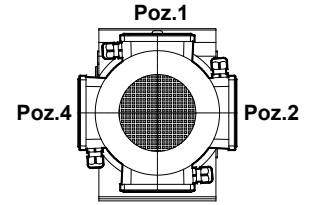

Poz.1

Poz.2

Poz.3

Poz.4

71-80

Tip / Type / Typ

Opsiyonel flanş ölçüleri için sayfa 587'ye bakınız.
Please see on page 587 for optional flange dimensions
Siehe Seite 587 für auswählbare Flanschabmessungen

* " k1 " Ölçüsü frenli redüktörlere aittir.
Dimension " k1 " is for motors with brake.
Maße " k1 " ist für Bremsenmotoren.

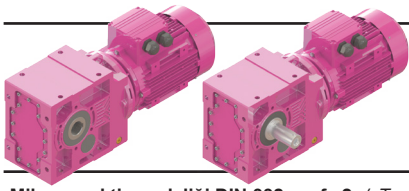

Ölçü Sayfaları Dimension Pages Abmessungsseiten

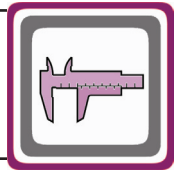

-Mil ucu çekirme deliği DIN 332 sayfa 2 / Tapped center hole to DIN 332, sheet 2 / Zentrierung mit Gewinde DIN 332, Blatt 2

KR475.00
KR476.00

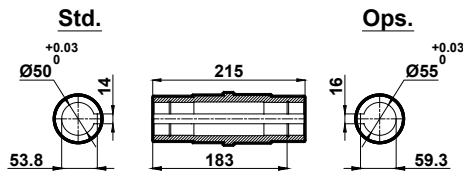
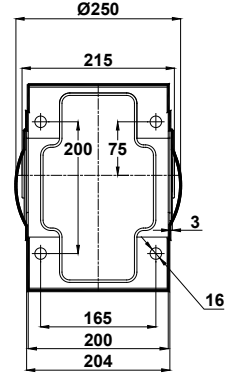
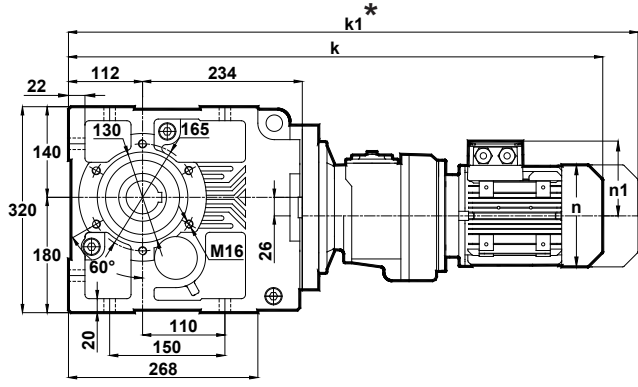

Klemens Pozisyonları
Terminal Box Positions
Klemmenkasten Positionen

	63	71
k	749	776
k1	810	867
n	121	137
n1	97	112

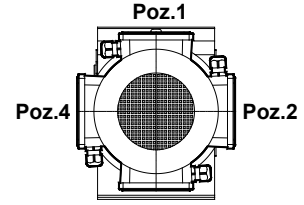

Poz.3
63-71
Tip / Type / Typ

KR475.01
KR476.01

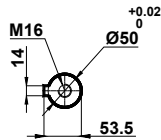
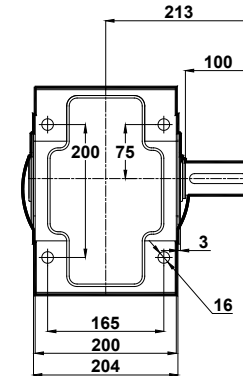
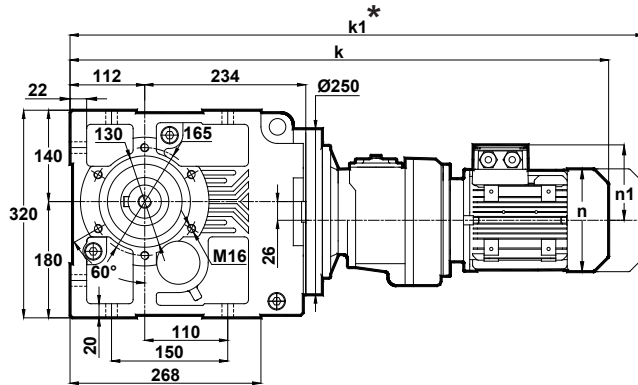

	63	71
k	749	776
k1	810	867
n	121	137
n1	97	112

* " k1 " Ölçüsü frenli redüktörlere aittir.
Dimension " k1 " is for motors with brake.
Maße " k1 " ist für Bremsenmotoren.

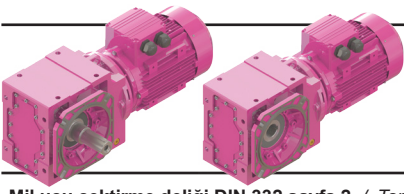

Ölçü Sayfaları

Dimension Pages

Abmessungsseiten

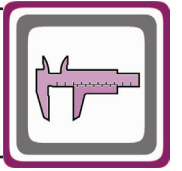

-Mil ucu çektirme deliği DIN 332 sayfa 2 / Tapped center hole to DIN 332, sheet 2 / Zentrierung mit Gewinde DIN 332, Blatt 2

KR475.02
KR476.02

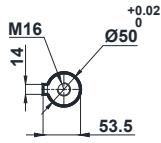
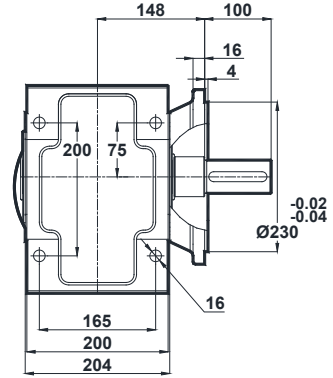
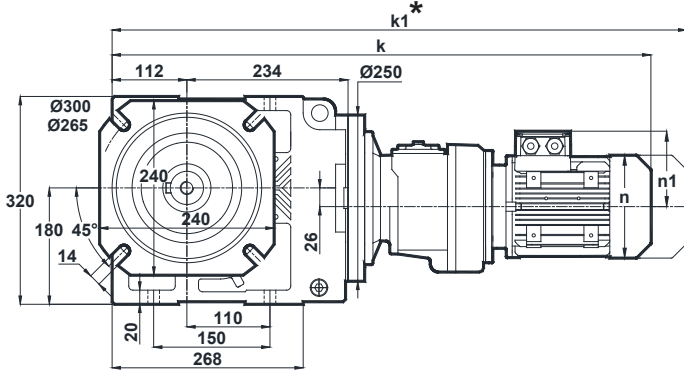

	63	71
k	749	776
k1	810	867
n	121	137
n1	97	112

Klemens Pozisyonları
Terminal Box Positions
Klemmenkasten Positionen

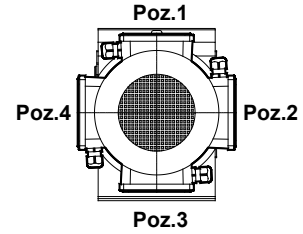

63-71
Tip / Type / Typ

Opsiyonel flanş ölçüleri için sayfa 587'ye bakınız.
Please see on page 587 for optional flange dimensions
Siehe Seite 587 für auswählbare Flanschabmessungen

KR475.03
KR476.03

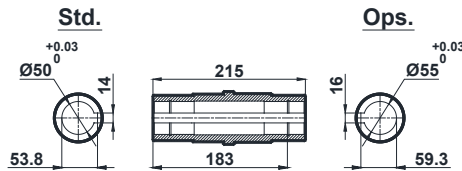
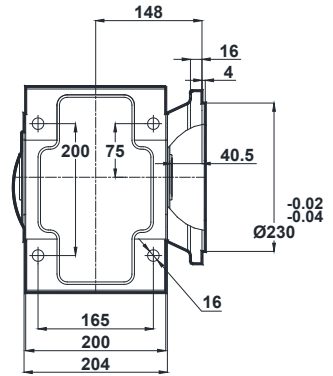
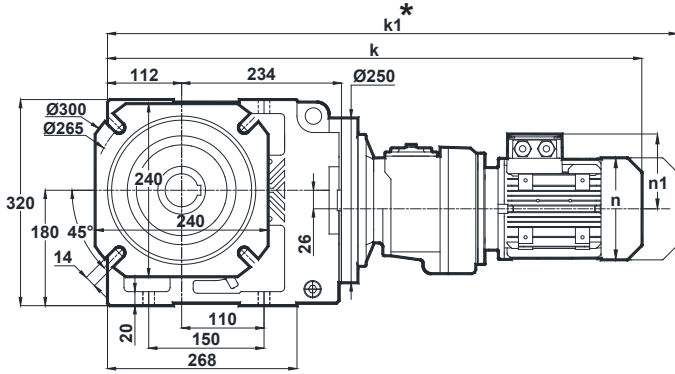

	63	71
k	749	776
k1	810	867
n	121	137
n1	97	112

Opsiyonel flanş ölçüleri için sayfa 587'ye bakınız.
Please see on page 587 for optional flange dimensions
Siehe Seite 587 für auswählbare Flanschabmessungen

* " k1 " Ölçüsü frenli redüktörlere aittir.
Dimension " k1 " is for motors with brake.
Maße " k1 " ist für Bremsenmotoren.

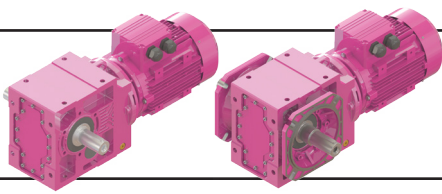

Ölçü Sayfaları Dimension Pages Abmessungsseiten

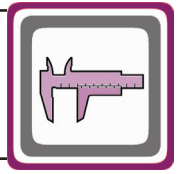

-Mil ucu çektirme deliği DIN 332 sayfa 2 / Tapped center hole to DIN 332, sheet 2 / Zentrierung mit Gewinde DIN 332, Blatt 2

KR475.04
KR476.04

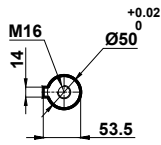
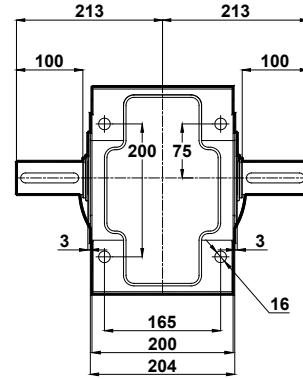
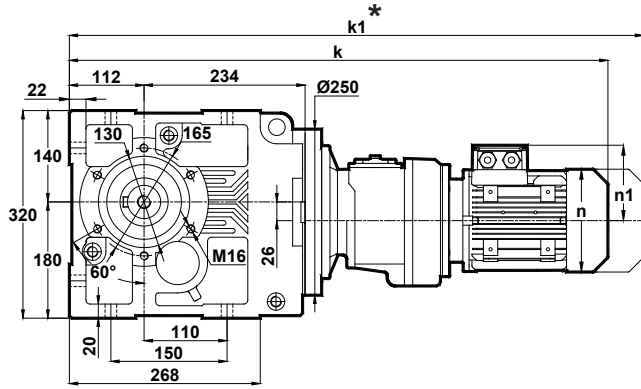

	63	71
k	749	776
k1	810	867
n	121	137
n1	97	112

Klemens Pozisyonları
Terminal Box Positions
Klemmenkasten Positionen

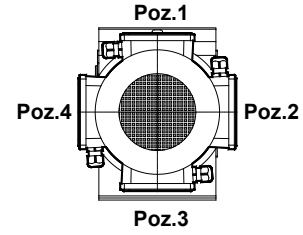

63-71
Tip / Type / Typ

KR475.05
KR476.05

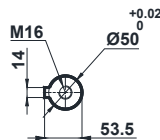
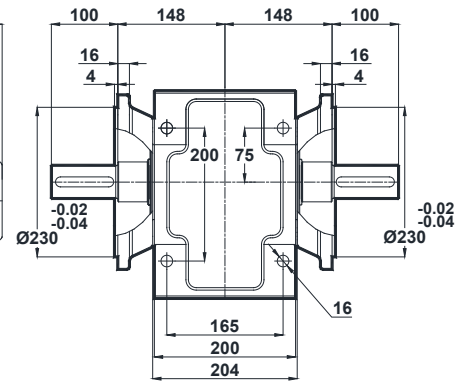
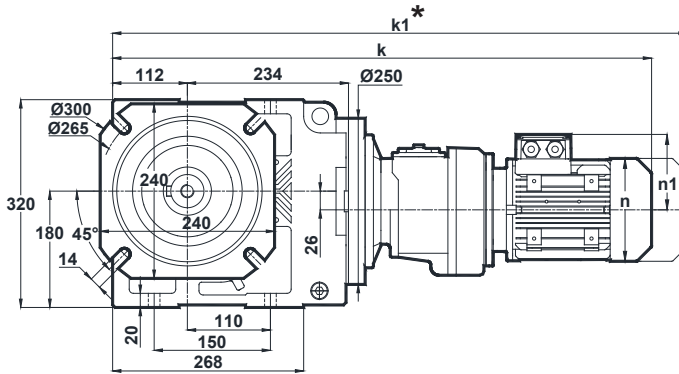

	63	71
k	749	776
k1	810	867
n	121	137
n1	97	112

Opsiyonel flanş ölçüleri için sayfa 587'ye bakınız.
Please see on page 587 for optional flange dimensions
Siehe Seite 587 für auswählbare Flanschabmessungen

* " k1 " Ölçüsü frenli redüktörlere aittir.
Dimension " k1 " is for motors with brake.
Maße " k1 " ist für Bremsenmotoren.

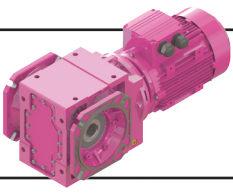

Ölçü Sayfaları Dimension Pages Abmessungsseiten

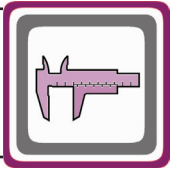

-Mil ucu çektirme deliği DIN 332 sayfa 2 / Tapped center hole to DIN 332, sheet 2 / Zentrierung mit Gewinde DIN 332, Blatt 2

KR475.08
KR476.08

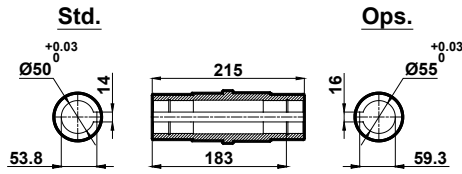
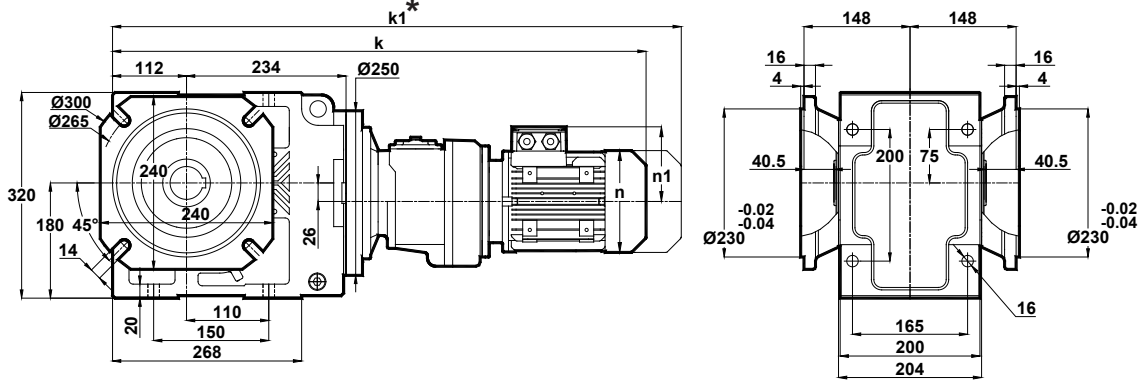

Klemens Pozisyonları
Terminal Box Positions
Klemmenkasten Positionen

	63	71
k	749	776
k1	810	867
n	121	137
n1	97	112

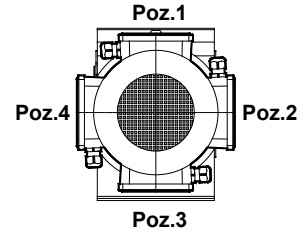

63-71
Tip / Type / Typ

Opsiyonel flanş ölçüleri için sayfa 587'ye bakınız.
Please see on page 587 for optional flange dimensions
Siehe Seite 587 für auswählbare Flanschabmessungen

* "k1" Ölçüsü frenli redüktörlere aittir.
Dimension "k1" is for motors with brake.
Maße "k1" ist für Bremsenmotoren.

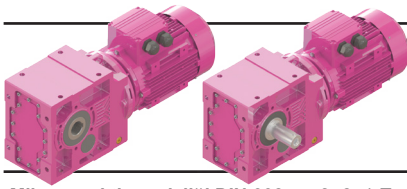

Ölçü Sayfaları

Dimension Pages

Abmessungsseiten

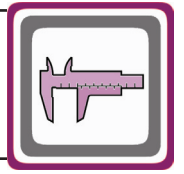

-Mil ucu çektirme deliği DIN 332 sayfa 2 / Tapped center hole to DIN 332, sheet 2 / Zentrierung mit Gewinde DIN 332, Blatt 2

KR573.00

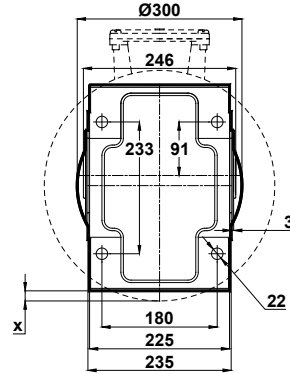
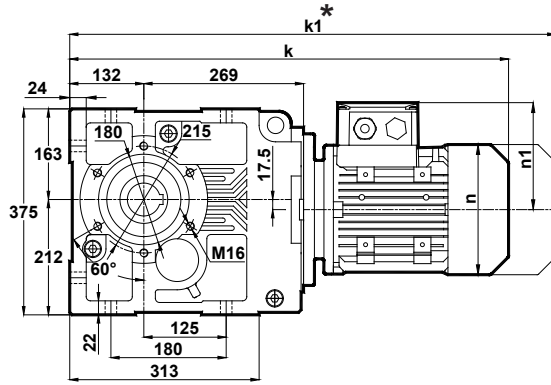

Std.

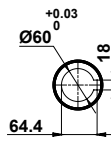

Ops.

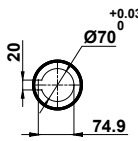

x: Motor Ayak bağlantı yüzeyinin altında ise
x: If Motor is lower than foot mounting plane
x: Wenn der Motor unter der Fußmontageebene ist

Klemens Pozisyonları
Terminal Box Positions
Klemmenkasten Positionen

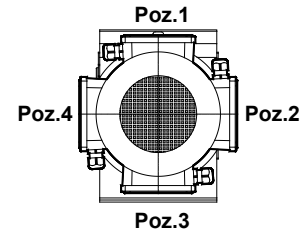

Poz.3
100-112-132-160-180
Tip / Type / Typ

	100L	112M	132S	132M	160M	160L	180M	180L
k	719	743	829.5	829.5	925.5	925.5	997.5	997.5
k1	827.5	847.5	959.5	959.5	1073.5	1073.5	1156	1156
n	193	215	257	257	316	316	348	348
n1	149	161	181	181	224	224	250	250
x	-	-	-	-	-	-	-	-

KR573.01

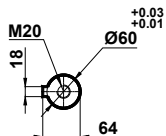
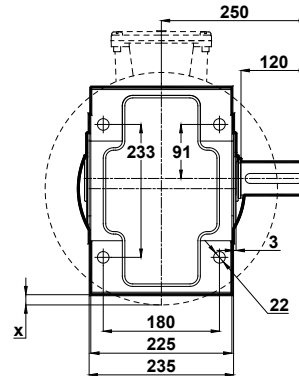
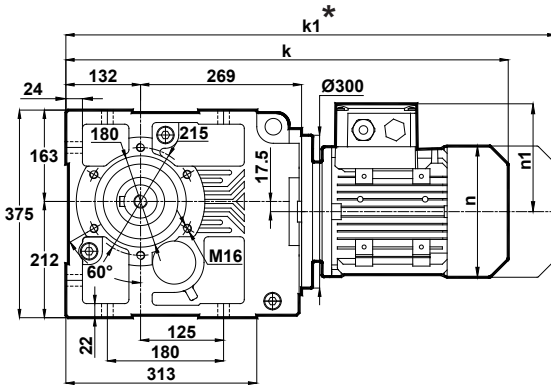

x: Motor Ayak bağlantı yüzeyinin altında ise
x: If Motor is lower than foot mounting plane
x: Wenn der Motor unter der Fußmontageebene ist

	100L	112M	132S	132M	160M	160L	180M	180L
k	719	743	829.5	829.5	925.5	925.5	997.5	997.5
k1	827.5	847.5	959.5	959.5	1073.5	1073.5	1156	1156
n	193	215	257	257	316	316	348	348
n1	149	161	181	181	224	224	250	250
x	-	-	-	-	-	-	-	-

* "k1" Ölçüsü frenli redüktörlere aittir.
Dimension "k1" is for motors with brake.
Maße "k1" ist für Bremsenmotoren.

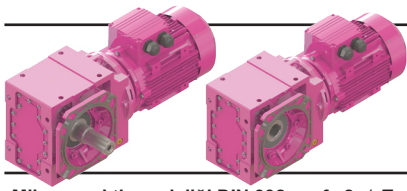

Ölçü Sayfaları Dimension Pages Abmessungsseiten

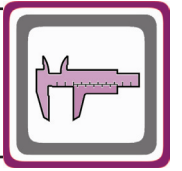

-Mil ucu çektirme deliği DIN 332 sayfa 2 / Tapped center hole to DIN 332, sheet 2 / Zentrierung mit Gewinde DIN 332, Blatt 2

KR573.02

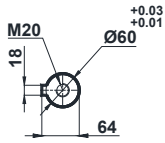
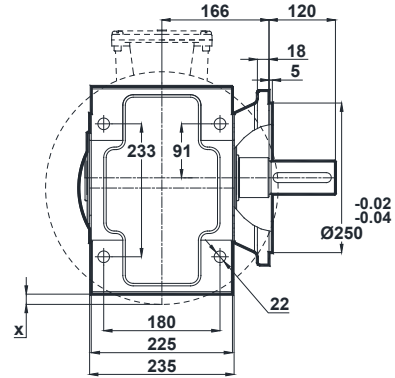
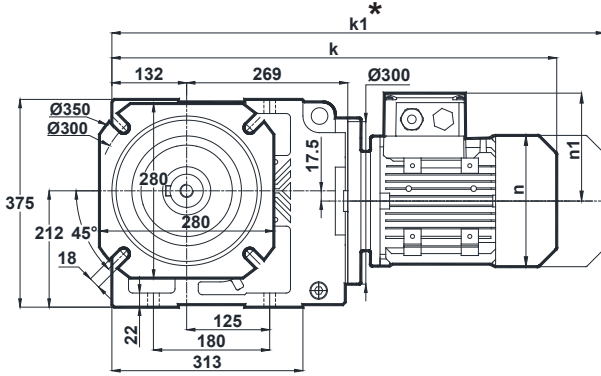

x: Motor Ayak bağlantı yüzeyinin altında ise
x: If Motor is lower than foot mounting plane
x: Wenn der Motor unter der Fußmontageebene ist

Klemens Pozisyonları
Terminal Box Positions
Klemmenkasten Positionen

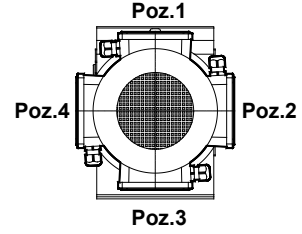

Poz.3
100-112-132-160-180
Tip / Type / Typ

Opsiyonel flanş ölçüleri için sayfa 587'ye bakınız.
Please see on page 587 for optional flange dimensions
Siehe Siete 587 für auswählbare Flanschabmessungen

KR573.03

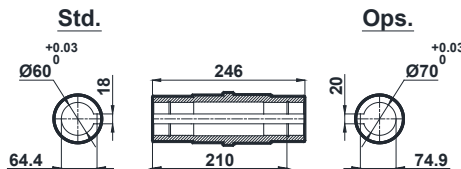
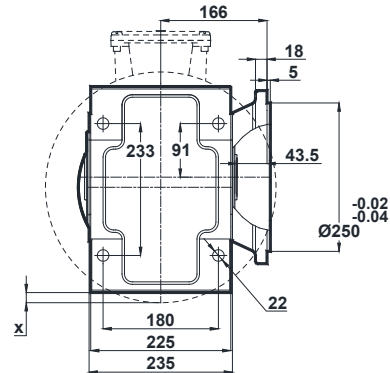
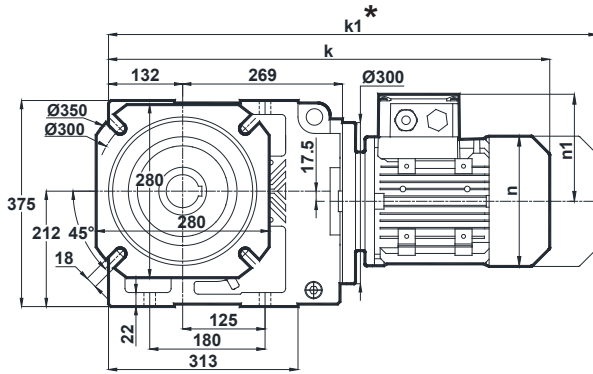

x: Motor Ayak bağlantı yüzeyinin altında ise
x: If Motor is lower than foot mounting plane
x: Wenn der Motor unter der Fußmontageebene ist

Opsiyonel flanş ölçüleri için sayfa 587'ye bakınız.
Please see on page 587 for optional flange dimensions
Siehe Siete 587 für auswählbare Flanschabmessungen

	100L	112M	132S	132M	160M	160L	180M	180L
k	719	743	829.5	829.5	925.5	925.5	997.5	997.5
k1	827.5	847.5	959.5	959.5	1073.5	1073.5	1156	1156
n	193	215	257	257	316	316	348	348
n1	149	161	181	181	224	224	250	250
x	-	-	-	-	-	-	-	-

* "k1" Ölçüsü frenli redüktörlere aittir.
Dimension "k1" is for motors with brake.
Maße "k1" ist für Bremsenmotoren.

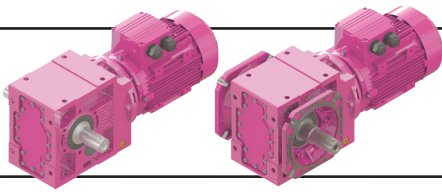

Ölçü Sayfaları Dimension Pages Abmessungsseiten

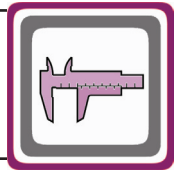

-Mil ucu çektirme deliği DIN 332 sayfa 2 / Tapped center hole to DIN 332, sheet 2 / Zentrierung mit Gewinde DIN 332, Blatt 2

KR573.04

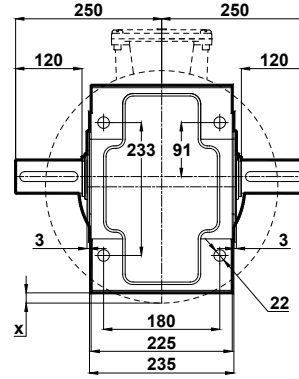
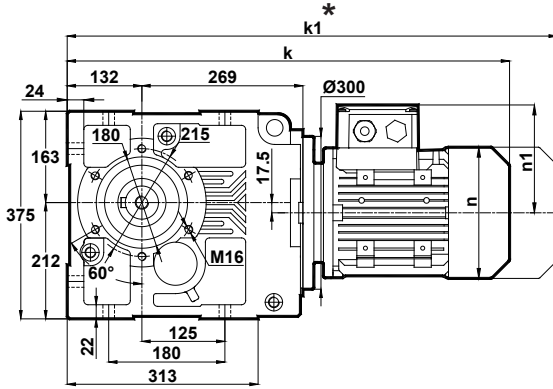

x: Motor Ayak bağlantı yüzeyinin altında ise
x: If Motor is lower than foot mounting plane
x: Wenn der Motor unter der Fußmontageebene ist

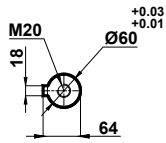

Klemens Pozisyonları
Terminal Box Positions
Klemmenkasten Positionen

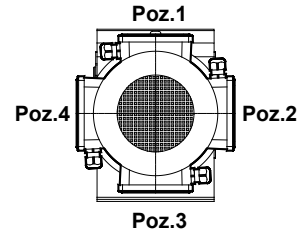

100-112-132-160-180
Tip / Type / Typ

	100L	112M	132S	132M	160M	160L	180M	180L
k	719	743	829.5	829.5	925.5	925.5	997.5	997.5
k1	827.5	847.5	959.5	959.5	1073.5	1073.5	1156	1156
n	193	215	257	257	316	316	348	348
n1	149	161	181	181	224	224	250	250
x	-	-	-	-	-	-	-	-

KR573.05

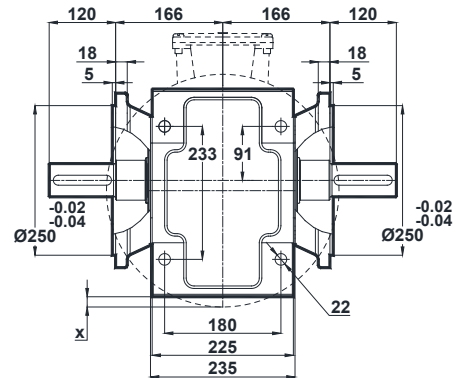
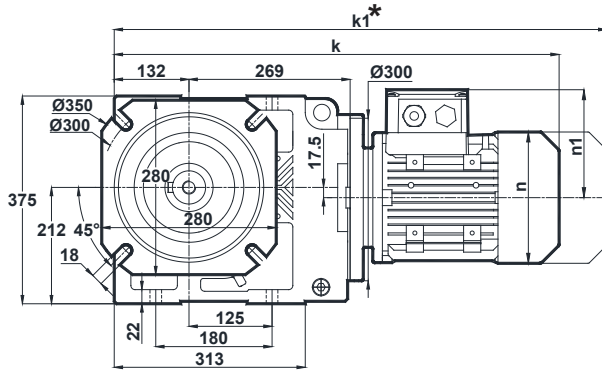

x: Motor Ayak bağlantı yüzeyinin altında ise
x: If Motor is lower than foot mounting plane
x: Wenn der Motor unter der Fußmontageebene ist

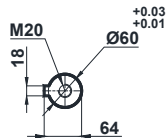

Opsiyonel flanş ölçüleri için sayfa 587'ye bakınız.
Please see on page 587 for optional flange dimensions
Siehe Seite 587 für auswählbare Flanschabmessungen

	100L	112M	132S	132M	160M	160L	180M	180L
k	719	743	829.5	829.5	925.5	925.5	997.5	997.5
k1	827.5	847.5	959.5	959.5	1073.5	1073.5	1156	1156
n	193	215	257	257	316	316	348	348
n1	149	161	181	181	224	224	250	250
x	-	-	-	-	-	-	-	-

* "k1" Ölçüsü frenli redüktörlere aittir.
Dimension "k1" is for motors with brake.
Maße "k1" ist für Bremsenmotoren.

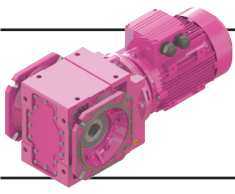

Ölçü Sayfaları Dimension Pages Abmessungsseiten

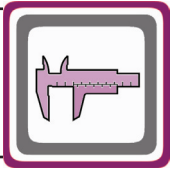

-Mil ucu çektirme deliği DIN 332 sayfa 2 / Tapped center hole to DIN 332, sheet 2 / Zentrierung mit Gewinde DIN 332, Blatt 2

KR573.08

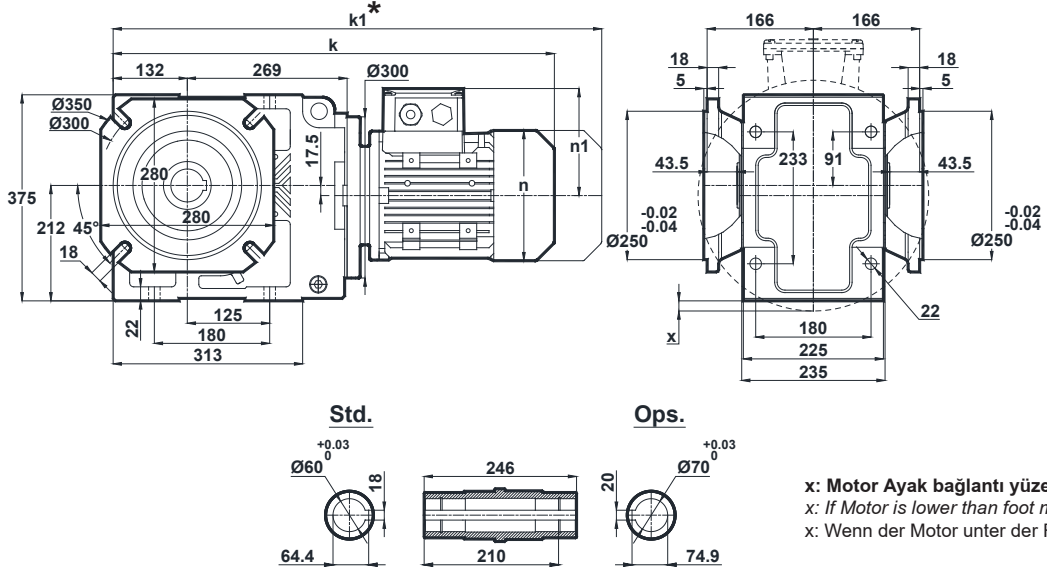

	100L	112M	132S	132M	160M	160L	180M	180L
k	719	743	829.5	829.5	925.5	925.5	997.5	997.5
k1	827.5	847.5	959.5	959.5	1073.5	1073.5	1156	1156
n	193	215	257	257	316	316	348	348
n1	149	161	181	181	224	224	250	250
x	-	-	-	-	-	-	-	-

x: Motor Ayak bağlantı yüzeyinin altında ise
x: If Motor is lower than foot mounting plane
x: Wenn der Motor unter der Fußmontageebene ist

Klemens Pozisyonları
Terminal Box Positions
Klemmenkasten Positionen

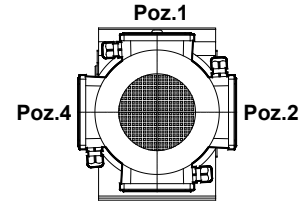

Poz.1
Poz.2
Poz.3
100-112-132-160-180
Tip / Type / Typ

Opsiyonel flanş ölçüleri için sayfa 587'ye bakınız.
Please see on page 587 for optional flange dimensions
Siehe Seite 587 für auswählbare Flanschabmessungen

* "k1" Ölçüsü frenli redüktörlere aittir.
Dimension "k1" is for motors with brake.
Maße "k1" ist für Bremsenmotoren.

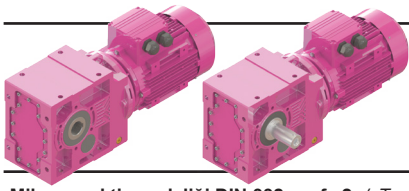

Ölçü Sayfaları

Dimension Pages

Abmessungsseiten

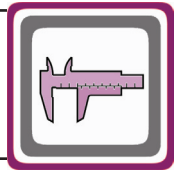

-Mil ucu çektirme deliği DIN 332 sayfa 2 / Tapped center hole to DIN 332, sheet 2 / Zentrierung mit Gewinde DIN 332, Blatt 2

KR574.00

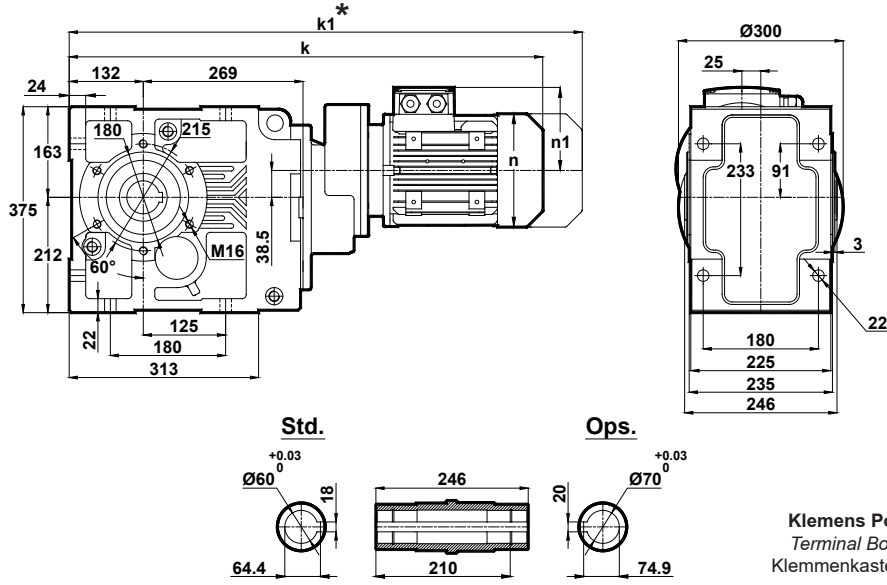

	71	80	90S	90L	100L
k	699	733	772	772	820
k1	790	826	875.5	875.5	928.5
n	137	155	176	176	193
n1	112	123	132	132	149

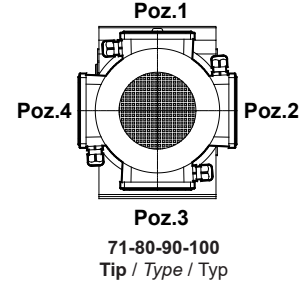

KR574.01

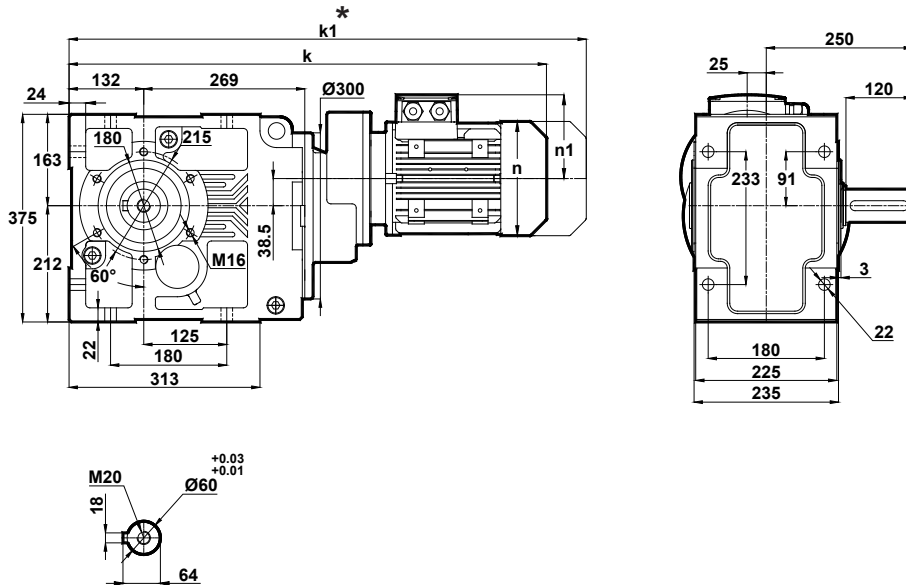

	71	80	90S	90L	100L
k	699	733	772	772	820
k1	790	826	875.5	875.5	928.5
n	137	155	176	176	193
n1	112	123	132	132	149

* "k1" Ölçüsü frenli redüktörlere aittir.
Dimension "k1" is for motors with brake.
Maße "k1" ist für Bremsenmotoren.

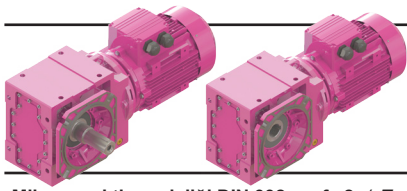

Ölçü Sayfaları Dimension Pages Abmessungsseiten

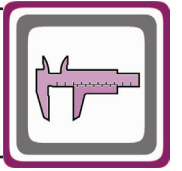

-Mil ucu çektirme deliği DIN 332 sayfa 2 / Tapped center hole to DIN 332, sheet 2 / Zentrierung mit Gewinde DIN 332, Blatt 2

KR574.02

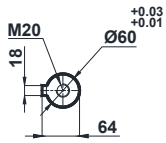
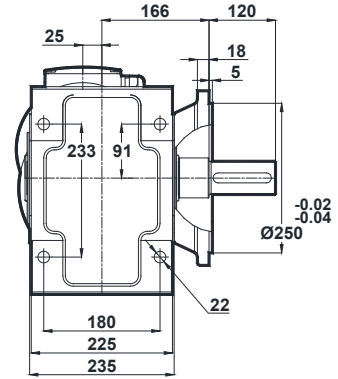
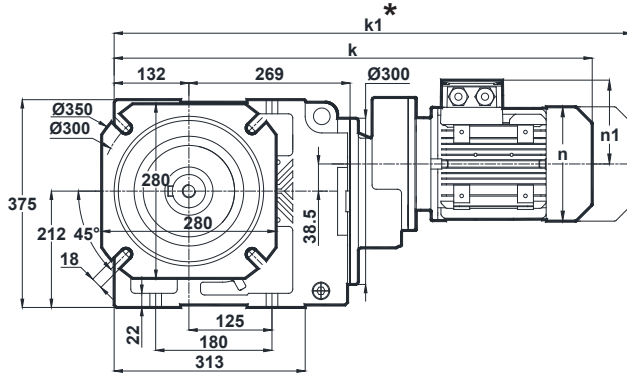

Klemens Pozisyonları
Terminal Box Positions
Klemmenkasten Positionen

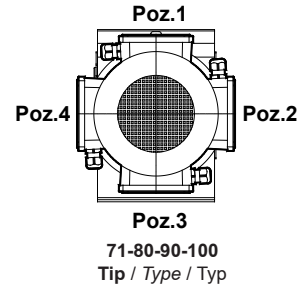

	71	80	90S	90L	100L
k	699	733	772	772	820
k1	790	826	875.5	875.5	928.5
n	137	155	176	176	193
n1	112	123	132	132	149

Opsiyonel flanş ölçüleri için sayfa 587'ye bakınız.
Please see on page 587 for optional flange dimensions
Siehe Seite 587 für auswählbare Flanschabmessungen

KR574.03

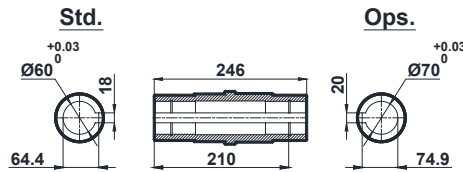
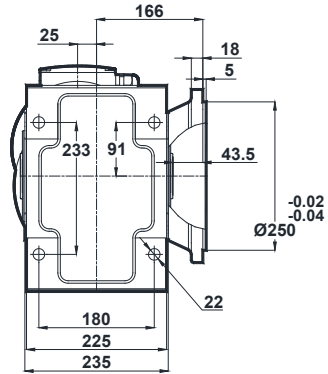
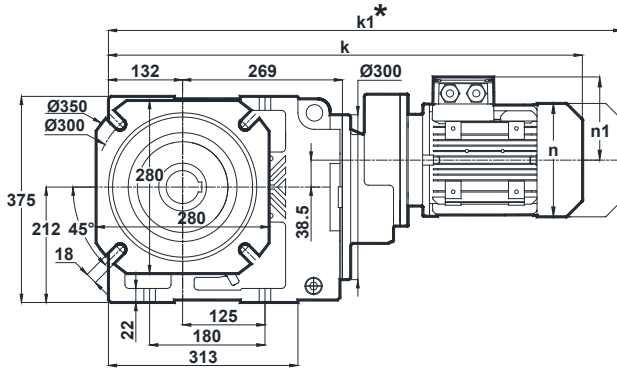

	71	80	90S	90L	100L
k	699	733	772	772	820
k1	790	826	875.5	875.5	928.5
n	137	155	176	176	193
n1	112	123	132	132	149

Opsiyonel flanş ölçüleri için sayfa 587'ye bakınız.
Please see on page 587 for optional flange dimensions
Siehe Seite 587 für auswählbare Flanschabmessungen

* " k1 " Ölçüsü frenli redüktörlere aittir.
Dimension " k1 " is for motors with brake.
Maße " k1 " ist für Bremsenmotoren.

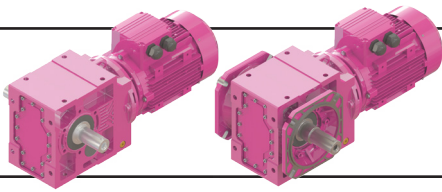

Ölçü Sayfaları Dimension Pages Abmessungsseiten

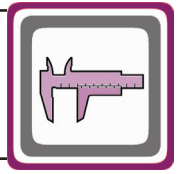

-Mil ucu çektirme deliği DIN 332 sayfa 2 / Tapped center hole to DIN 332, sheet 2 / Zentrierung mit Gewinde DIN 332, Blatt 2

KR574.04

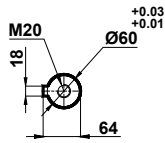
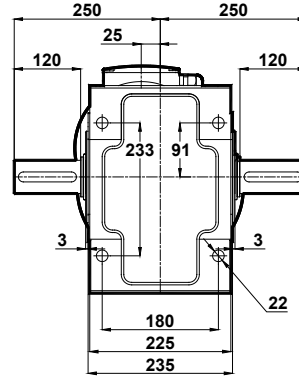
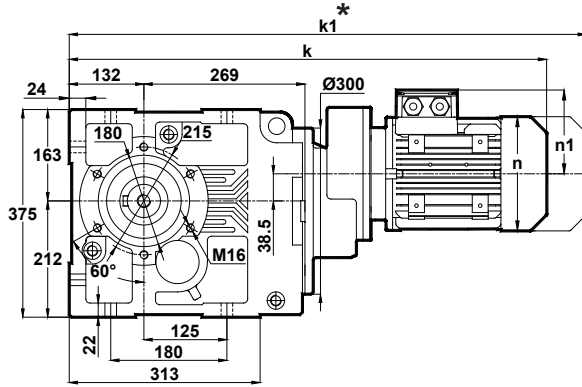

	71	80	90S	90L	100L
k	699	733	772	772	820
k1	790	826	875.5	875.5	928.5
n	137	155	176	176	193
n1	112	123	132	132	149

Klemens Pozisyonları
Terminal Box Positions
Klemmenkasten Positionen

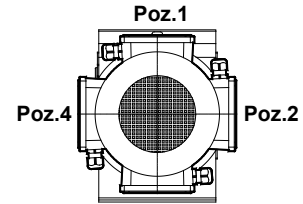

Poz.3
71-80-90-100
Tip / Type / Typ

KR574.05

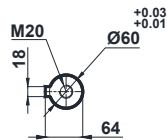
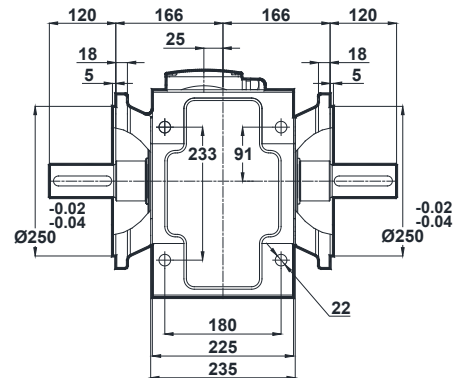
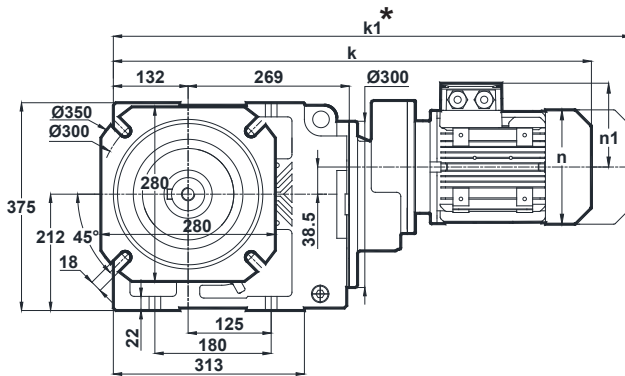

	71	80	90S	90L	100L
k	699	733	772	772	820
k1	790	826	875.5	875.5	928.5
n	137	155	176	176	193
n1	112	123	132	132	149

Opsiyonel flanş ölçüleri için sayfa 587'ye bakınız.
Please see on page 587 for optional flange dimensions
Siehe Seite 587 für auswählbare Flanschabmessungen

* "k1" Ölçüsü frenli redüktörlere aittir.
Dimension "k1" is for motors with brake.
Maße "k1" ist für Bremsenmotoren.

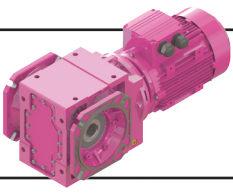

Ölçü Sayfaları Dimension Pages Abmessungenseiten

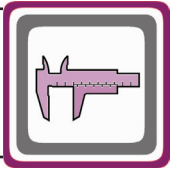

-Mil ucu çektirme deliği DIN 332 sayfa 2 / Tapped center hole to DIN 332, sheet 2 / Zentrierung mit Gewinde DIN 332, Blatt 2

KR574.08

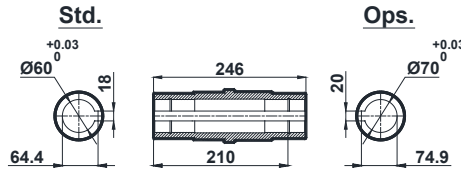
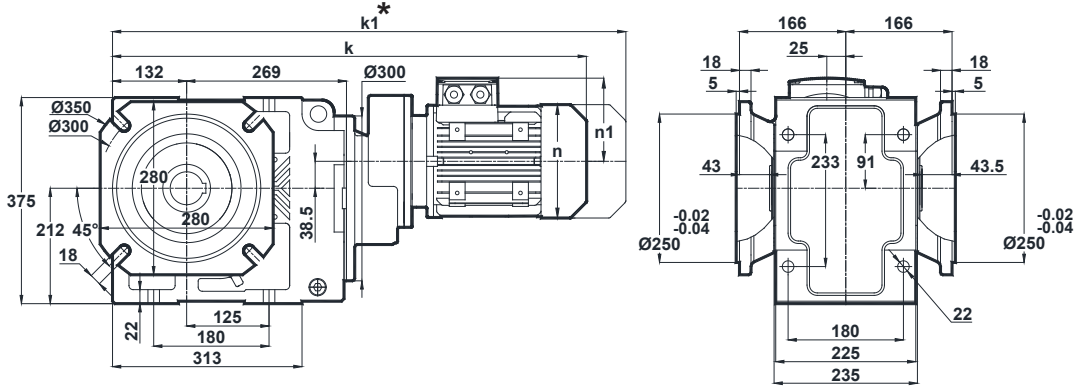

Klemens Pozisyonları
Terminal Box Positions
Klemmenkasten Positionen

	71	80	90S	90L	100L
k	699	733	772	772	820
k1	790	826	875.5	875.5	928.5
n	137	155	176	176	193
n1	112	123	132	132	149

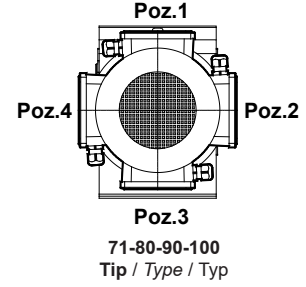

Opsiyonel flanş ölçüleri için sayfa 587'ye bakınız.
Please see on page 587 for optional flange dimensions
Siehe Seite 587 für auswählbare Flanschabmessungen

* "k1" Ölçüsü frenli redüktörlere aittir.
Dimension "k1" is for motors with brake.
Maße "k1" ist für Bremsenmotoren.

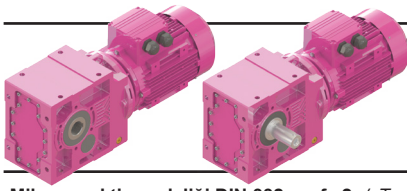

Ölçü Sayfaları

Dimension Pages

Abmessungsseiten

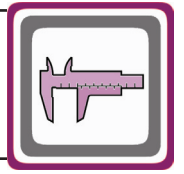

-Mil ucu çektirme deliği DIN 332 sayfa 2 / Tapped center hole to DIN 332, sheet 2 / Zentrierung mit Gewinde DIN 332, Blatt 2

KR575.00
KR576.00

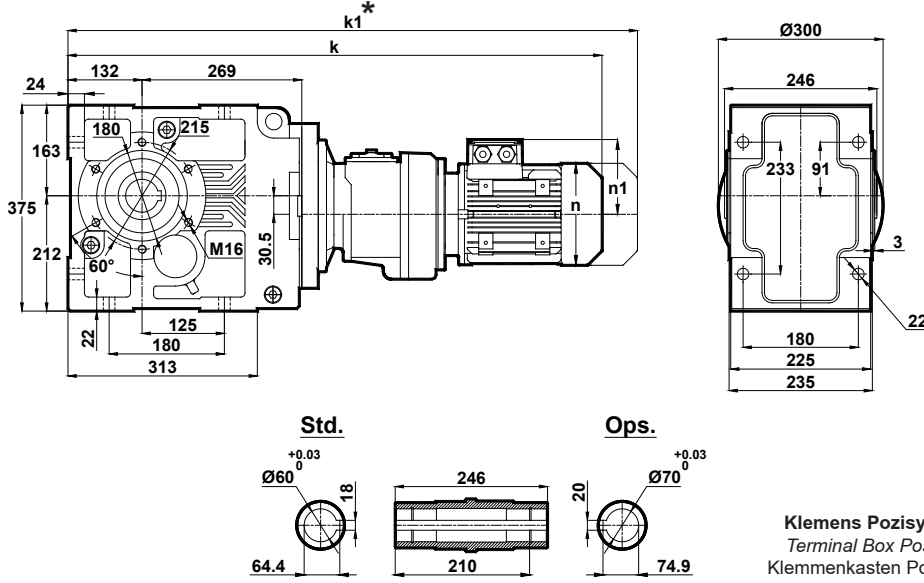

Klemens Pozisyonları
Terminal Box Positions
Klemmenkasten Positionen

	63	71	80
k	804	831	865
k1	865	922	958
n	121	137	155
n1	97	112	123

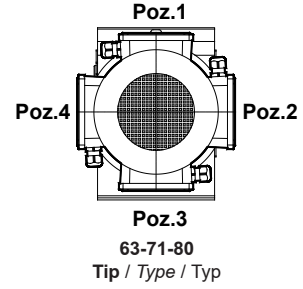

KR575.01
KR576.01

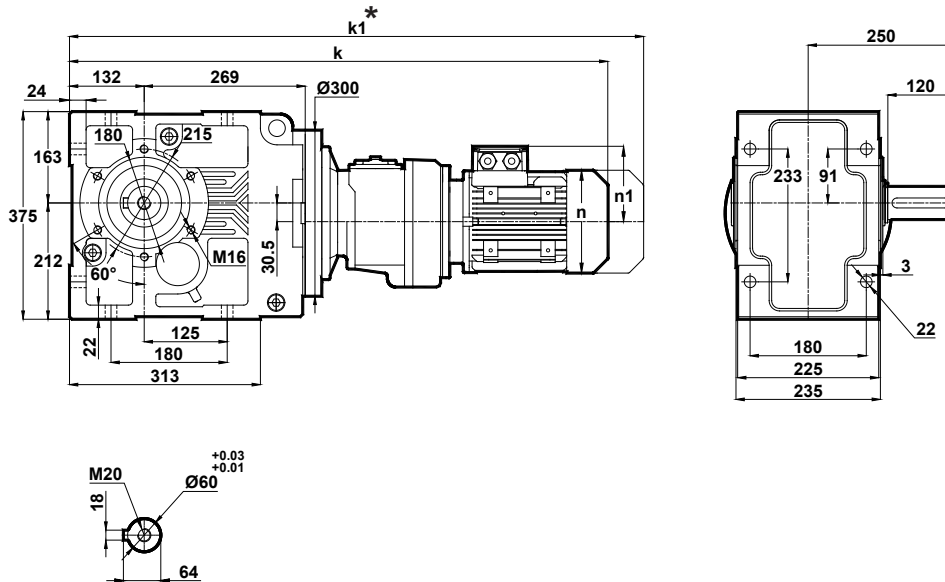

	63	71	80
k	804	831	865
k1	865	922	958
n	121	137	155
n1	97	112	123

* "k1" Ölçüsü frenli redüktörlere aittir.
Dimension "k1" is for motors with brake.
Maße "k1" ist für Bremsenmotoren.

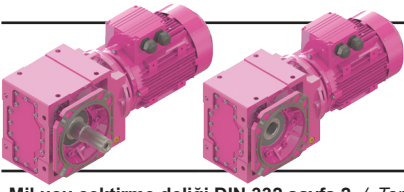

Ölçü Sayfaları

Dimension Pages

Abmessungsseiten

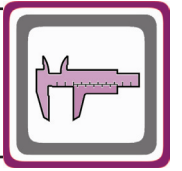

-Mil ucu çektirme deliği DIN 332 sayfa 2 / Tapped center hole to DIN 332, sheet 2 / Zentrierung mit Gewinde DIN 332, Blatt 2

KR575.02
KR576.02

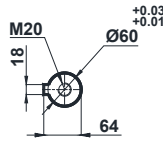
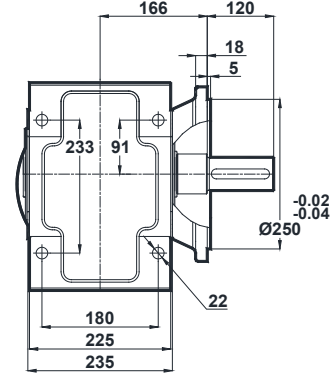
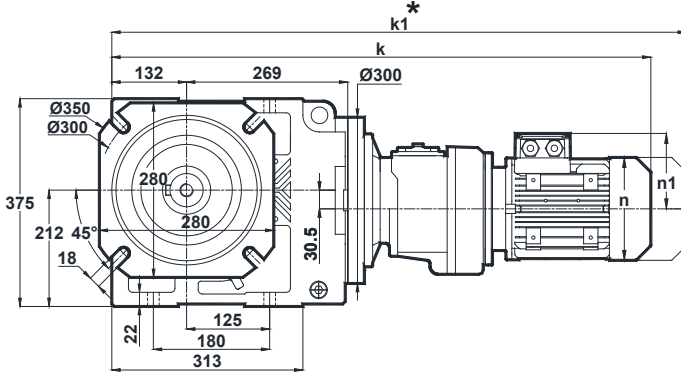

Klemens Pozisyonları
Terminal Box Positions
Klemmenkasten Positionen

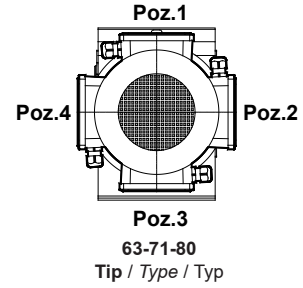

	63	71	80
k	804	831	865
k1	865	922	958
n	121	137	155
n1	97	112	123

Opsiyonel flanş ölçüleri için sayfa 587'ye bakınız.
Please see on page 587 for optional flange dimensions
Siehe Seite 587 für auswählbare Flanschabmessungen

KR575.03
KR576.03

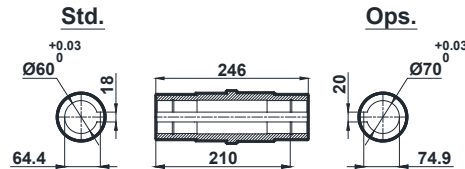
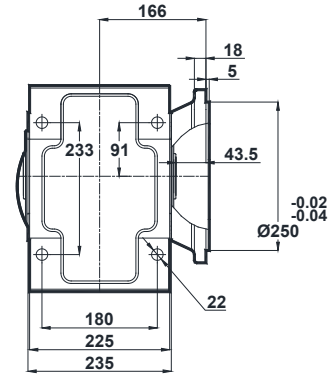
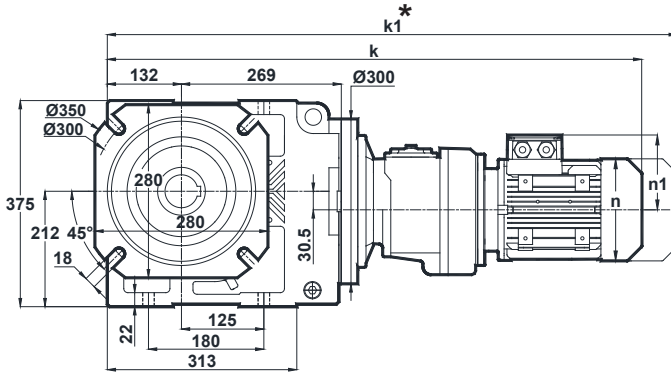

	63	71	80
k	804	831	865
k1	865	922	958
n	121	137	155
n1	97	112	123

Opsiyonel flanş ölçüleri için sayfa 587'ye bakınız.
Please see on page 587 for optional flange dimensions
Siehe Seite 587 für auswählbare Flanschabmessungen

* "k1" Ölçüsü frenli redüktörlere aittir.
Dimension "k1" is for motors with brake.
Maße "k1" ist für Bremsenmotoren.

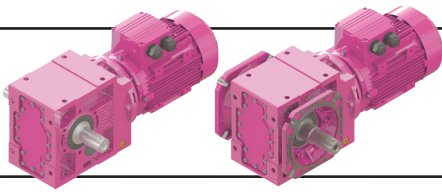

Ölçü Sayfaları Dimension Pages Abmessungsseiten

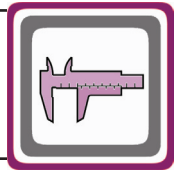

-Mil ucu çektirme deliği DIN 332 sayfa 2 / Tapped center hole to DIN 332, sheet 2 / Zentrierung mit Gewinde DIN 332, Blatt 2

KR575.04
KR576.04

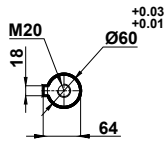
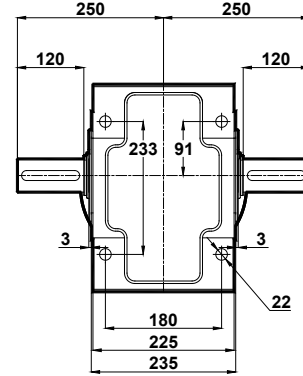
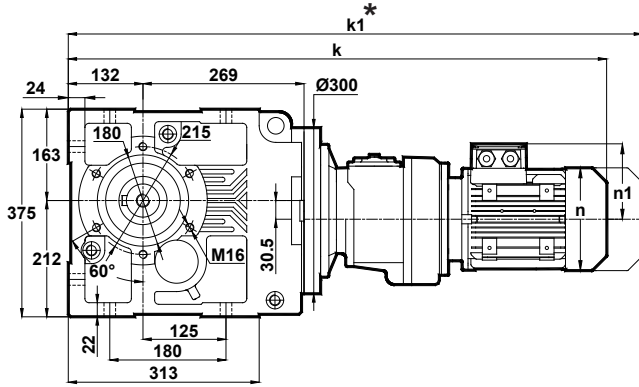

	63	71	80
k	804	831	865
k1	865	922	958
n	121	137	155
n1	97	112	123

Klemens Pozisyonları
Terminal Box Positions
Klemmenkasten Positionen

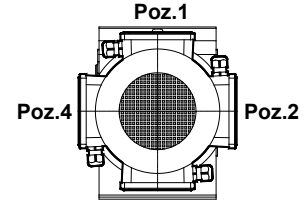

Poz.3
63-71-80
Tip / Type / Typ

KR575.05
KR576.05

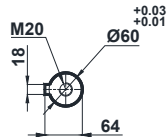
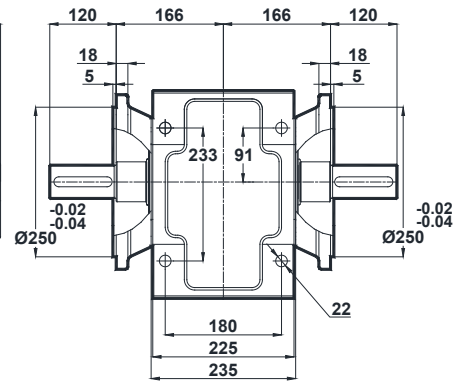
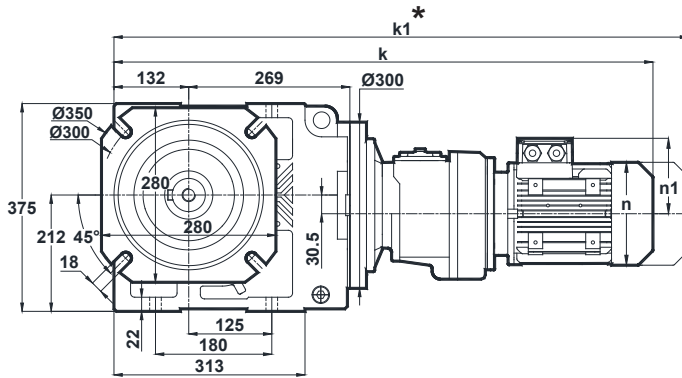

	63	71	80
k	804	831	865
k1	865	922	958
n	121	137	155
n1	97	112	123

Opsiyonel flanş ölçüleri için sayfa 587'ye bakınız.
Please see on page 587 for optional flange dimensions
Siehe Seite 587 für auswählbare Flanschabmessungen

* " k1 " Ölçüsü frenli redüktörlere aittir.
Dimension " k1 " is for motors with brake.
Maße " k1 " ist für Bremsenmotoren.

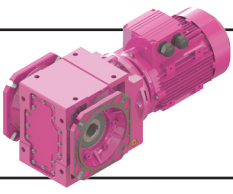

Ölçü Sayfaları Dimension Pages Abmessungsseiten

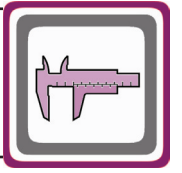

-Mil ucu çektirme deliği DIN 332 sayfa 2 / Tapped center hole to DIN 332, sheet 2 / Zentrierung mit Gewinde DIN 332, Blatt 2

KR575.08
KR576.08

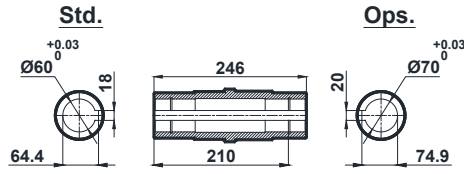
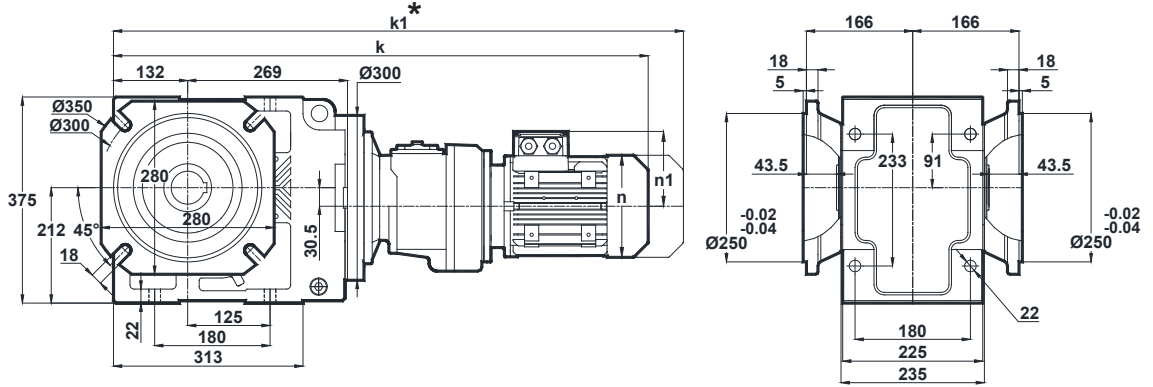

Klemens Pozisyonları
Terminal Box Positions
Klemmenkasten Positionen

	63	71	80
k	804	831	865
k1	865	922	958
n	121	137	155
n1	97	112	123

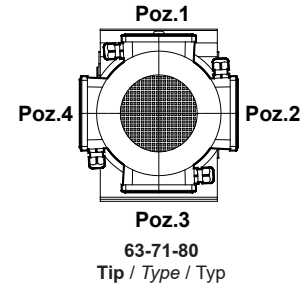

Opsiyonel flanş ölçüleri için sayfa 587'ye bakınız.
Please see on page 587 for optional flange dimensions
Siehe Seite 587 für auswählbare Flanschabmessungen

* "k1" Ölçüsü frenli redüktörlere aittir.
Dimension "k1" is for motors with brake.
Maße "k1" ist für Bremsenmotoren.

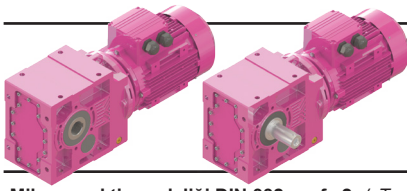

Ölçü Sayfaları

Dimension Pages

Abmessungsseiten

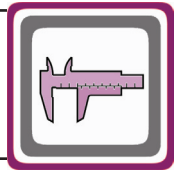

-Mil ucu çektirme deliği DIN 332 sayfa 2 / Tapped center hole to DIN 332, sheet 2 / Zentrierung mit Gewinde DIN 332, Blatt 2

KR673.00

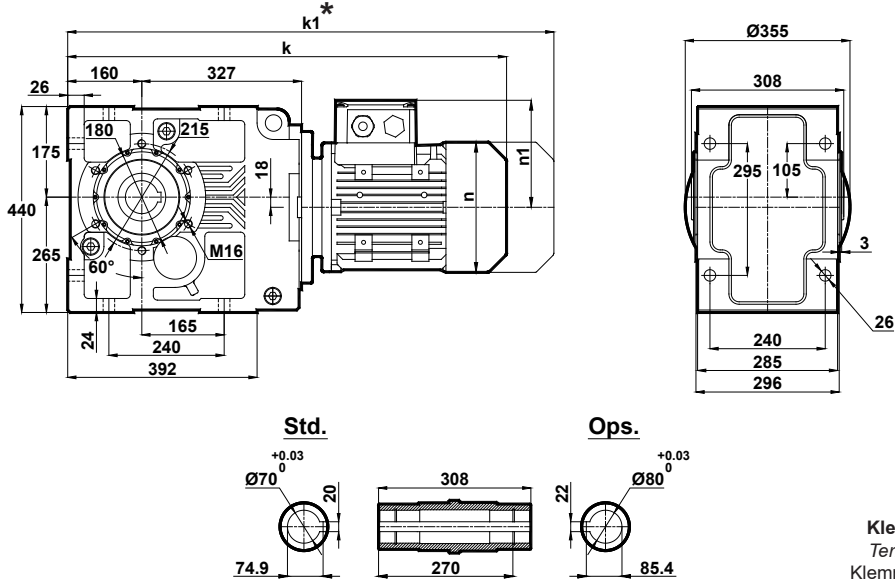

Klemens Pozisyonları
Terminal Box Positions
Klemmenkasten Positionen

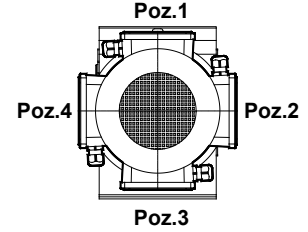

100-112-132-160-180-200-225
Tip / Type / Typ

	100L	112M	132S	132M	160M	160L	180M	180L	200L	225S	225M
k	797	821	907.5	907.5	1003.5	1003.5	1075.5	1075.5	1121.5	1148	1173
k1	905.5	925.5	1037.5	1037.5	1151.5	1151.5	1234	1234	1308	1313	1338
n	193	215	257	257	316	316	348	348	396	438	438
n1	149	161	181	181	224	224	250	250	287	316	316

KR673.01

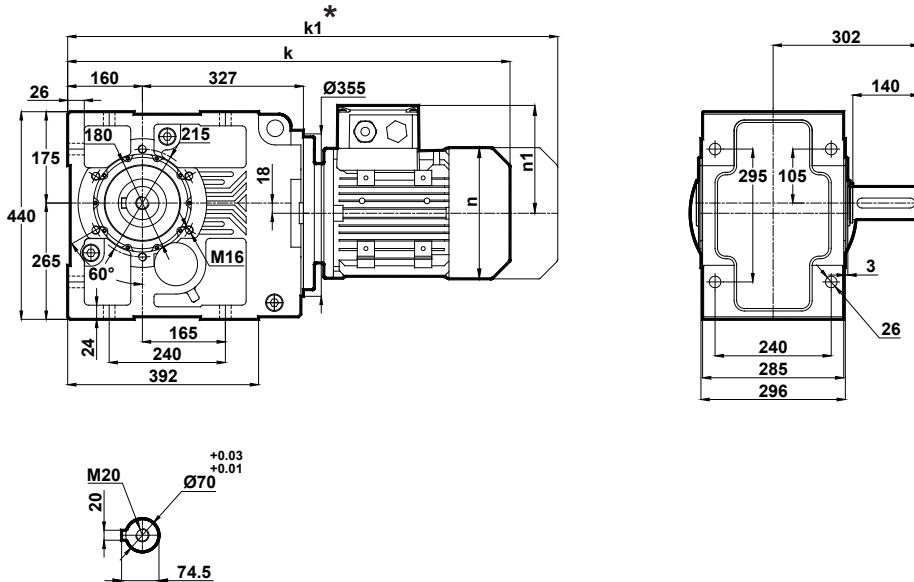

	100L	112M	132S	132M	160M	160L	180M	180L	200L	225S	225M
k	797	821	907.5	907.5	1003.5	1003.5	1075.5	1075.5	1121.5	1148	1173
k1	905.5	925.5	1037.5	1037.5	1151.5	1151.5	1234	1234	1308	1313	1338
n	193	215	257	257	316	316	348	348	396	438	438
n1	149	161	181	181	224	224	250	250	287	316	316

* "k1" Ölçüsü frenli redüktörlere aittir.
Dimension "k1" is for motors with brake.
Maße "k1" ist für Bremsenmotoren.

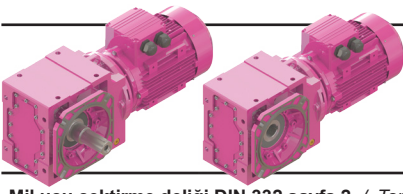

Ölçü Sayfaları Dimension Pages Abmessungenseiten

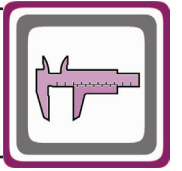

-Mil ucu çektirme deliği DIN 332 sayfa 2 / Tapped center hole to DIN 332, sheet 2 / Zentrierung mit Gewinde DIN 332, Blatt 2

KR673.02

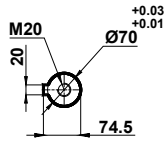
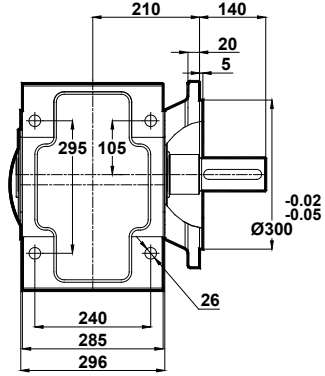
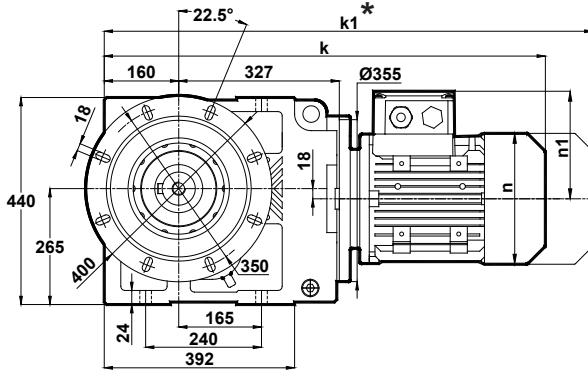

Klemens Pozisyonları
Terminal Box Positions
Klemmenkasten Positionen

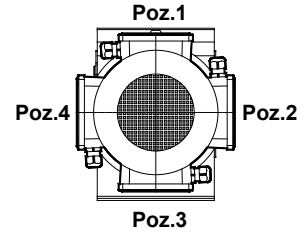

100-112-132-160-180-200-225
Tip / Type / Typ

	100L	112M	132S	132M	160M	160L	180M	180L	200L	225S	225M
k	797	821	907.5	907.5	1003.5	1003.5	1075.5	1075.5	1121.5	1148	1173
k1	905.5	925.5	1037.5	1037.5	1151.5	1151.5	1234	1234	1308	1313	1338
n	193	215	257	257	316	316	348	348	396	438	438
n1	149	161	181	181	224	224	250	250	287	316	316

Opsiyonel flanş ölçüleri için sayfa 587'ye bakınız.
Please see on page 587 for optional flange dimensions
Siehe Seite 587 für auswählbare Flanschabmessungen

KR673.03

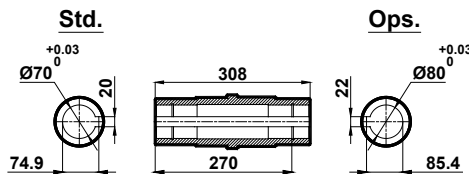
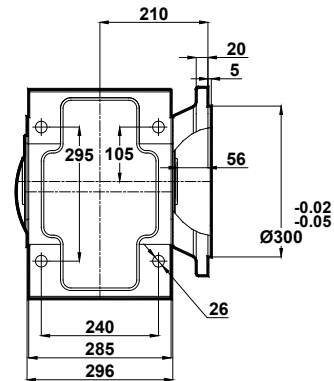
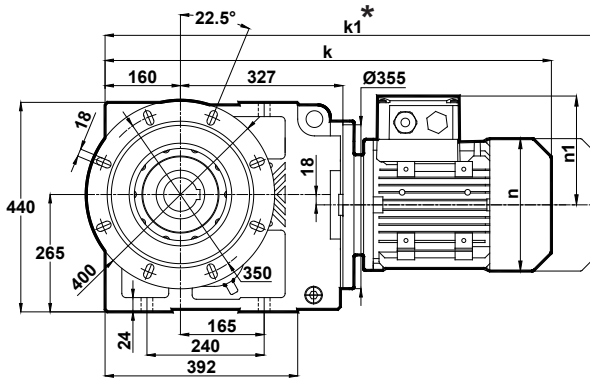

	100L	112M	132S	132M	160M	160L	180M	180L	200L	225S	225M
k	797	821	907.5	907.5	1003.5	1003.5	1075.5	1075.5	1121.5	1148	1173
k1	905.5	925.5	1037.5	1037.5	1151.5	1151.5	1234	1234	1308	1313	1338
n	193	215	257	257	316	316	348	348	396	438	438
n1	149	161	181	181	224	224	250	250	287	316	316

Opsiyonel flanş ölçüleri için sayfa 587'ye bakınız.
Please see on page 587 for optional flange dimensions
Siehe Seite 587 für auswählbare Flanschabmessungen

* "k1" Ölçüsü frenli redüktörlere aittir.
Dimension "k1" is for motors with brake.
Maße "k1" ist für Bremsenmotoren.

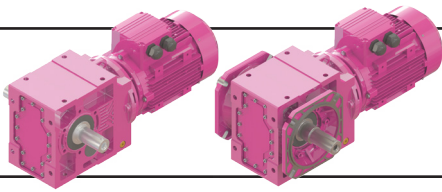

Ölçü Sayfaları Dimension Pages Abmessungsseiten

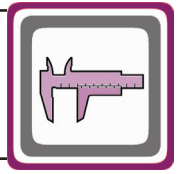

-Mil ucu çektirme deliği DIN 332 sayfa 2 / Tapped center hole to DIN 332, sheet 2 / Zentrierung mit Gewinde DIN 332, Blatt 2

KR673.04

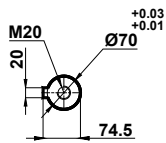
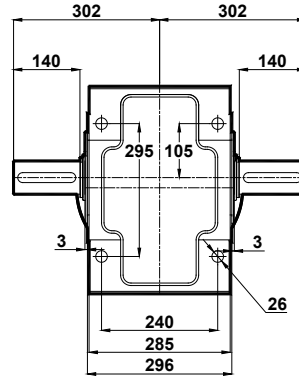
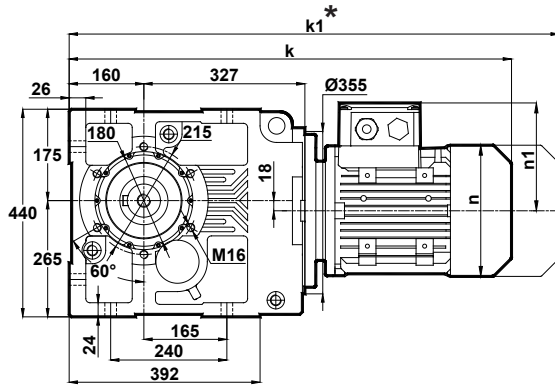

Klemens Pozisyonları
Terminal Box Positions
Klemmenkasten Positionen

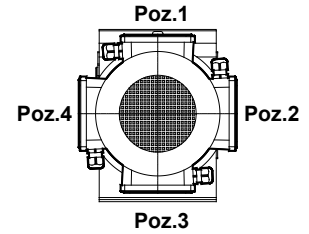

100-112-132-160-180-200-225
Tip / Type / Typ

	100L	112M	132S	132M	160M	160L	180M	180L	200L	225S	225M
k	797	821	907.5	907.5	1003.5	1003.5	1075.5	1075.5	1121.5	1148	1173
k1	905.5	925.5	1037.5	1037.5	1151.5	1151.5	1234	1234	1308	1313	1338
n	193	215	257	257	316	316	348	348	396	438	438
n1	149	161	181	181	224	224	250	250	287	316	316

KR673.05

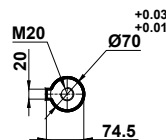
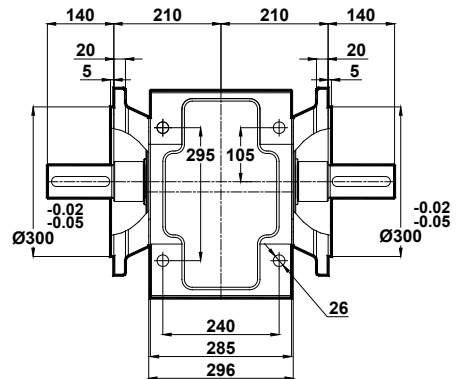
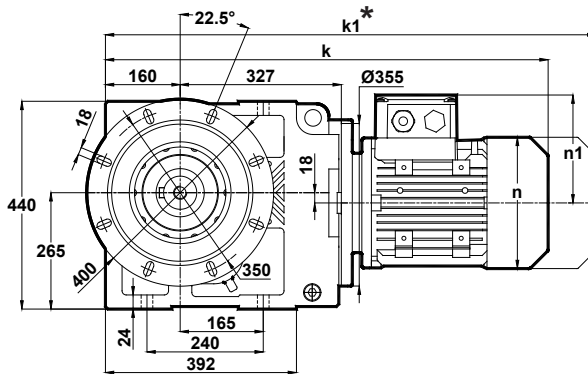

Opsiyonel flanş ölçüleri için sayfa 587'ye bakınız.
Please see on page 587 for optional flange dimensions
Siehe Seite 587 für auswählbare Flanschabmessungen

	100L	112M	132S	132M	160M	160L	180M	180L	200L	225S	225M
k	797	821	907.5	907.5	1003.5	1003.5	1075.5	1075.5	1121.5	1148	1173
k1	905.5	925.5	1037.5	1037.5	1151.5	1151.5	1234	1234	1308	1313	1338
n	193	215	257	257	316	316	348	348	396	438	438
n1	149	161	181	181	224	224	250	250	287	316	316

* "k1" Ölçüsü frenli redüktörlere aittir.
Dimension "k1" is for motors with brake.
Maße "k1" ist für Bremsenmotoren.

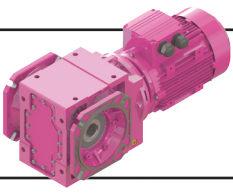

Ölçü Sayfaları Dimension Pages Abmessungsseiten

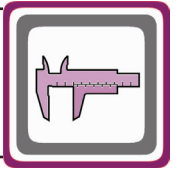

-Mil ucu çektirme deliği DIN 332 sayfa 2 / Tapped center hole to DIN 332, sheet 2 / Zentrierung mit Gewinde DIN 332, Blatt 2

KR673.08

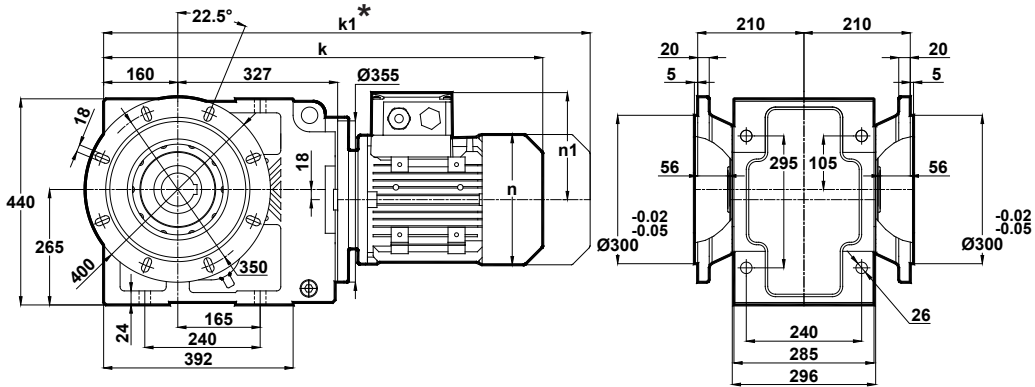

Std.

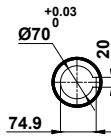

Ops.

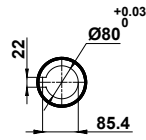

Klemens Pozisyonları
Terminal Box Positions
Klemmenkasten Positionen

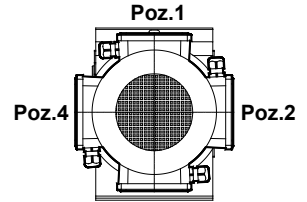

Poz.1

Poz.4

Poz.2

Poz.3

100-112-132-160-180-200-225
Tip / Type / Typ

	100L	112M	132S	132M	160M	160L	180M	180L	200L	225S	225M
k	797	821	907.5	907.5	1003.5	1003.5	1075.5	1075.5	1121.5	1148	1173
k1	905.5	925.5	1037.5	1037.5	1151.5	1151.5	1234	1234	1308	1313	1338
n	193	215	257	257	316	316	348	348	396	438	438
n1	149	161	181	181	224	224	250	250	287	316	316

Opsiyonel flanş ölçüleri için sayfa 587'ye bakınız.
Please see on page 587 for optional flange dimensions
Siehe Seite 587 für auswählbare Flanschabmessungen

* "k1" Ölçüsü frenli redüktörlere aittir.
Dimension "k1" is for motors with brake.
Maße "k1" ist für Bremsenmotoren.

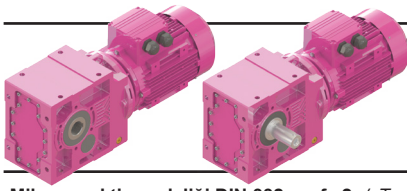

Ölçü Sayfaları Dimension Pages Abmessungsseiten

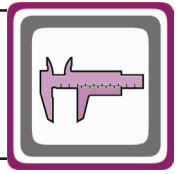

-Mil ucu çekirme deliği DIN 332 sayfa 2 / Tapped center hole to DIN 332, sheet 2 / Zentrierung mit Gewinde DIN 332, Blatt 2

KR674.00

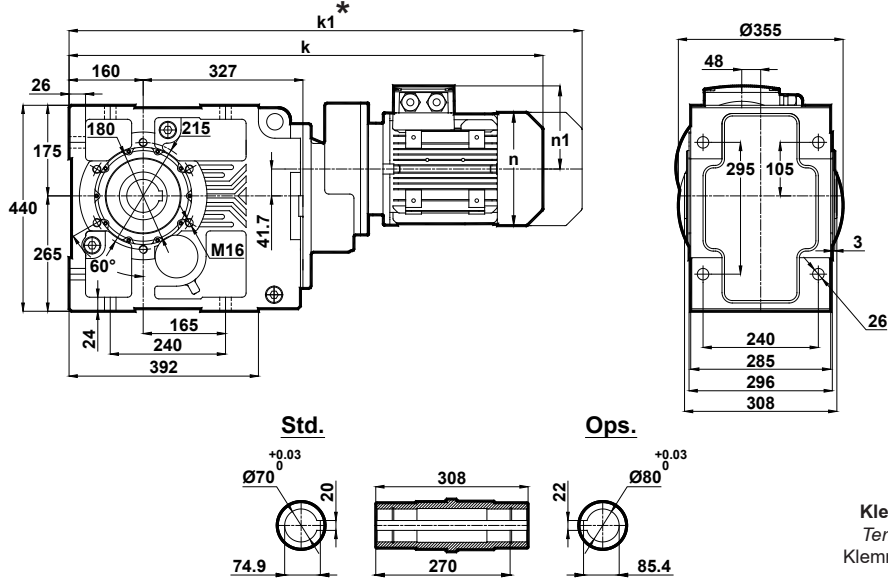

	80	90S	90L	100L
k	829.5	868.5	868.5	913.5
k1	922.5	972	972	1022
n	155	176	176	193
n1	123	132	132	149

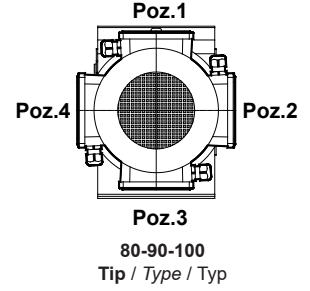

KR674.01

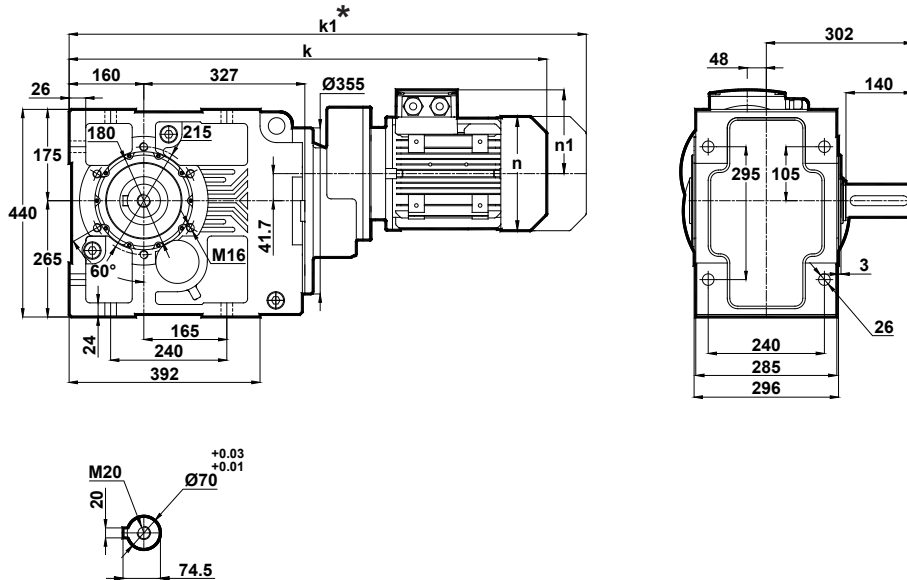

	80	90S	90L	100L
k	829.5	868.5	868.5	913.5
k1	922.5	972	972	1022
n	155	176	176	193
n1	123	132	132	149

* "k1" Ölçüsü frenli redüktörlere aittir.
Dimension "k1" is for motors with brake.
Maße "k1" ist für Bremsenmotoren.

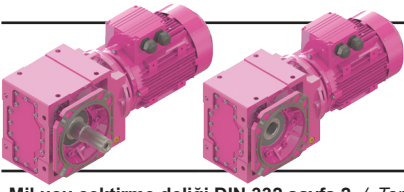

Ölçü Sayfaları Dimension Pages Abmessungsseiten

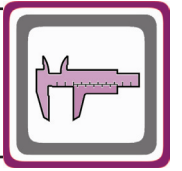

-Mil ucu çektirme deliği DIN 332 sayfa 2 / Tapped center hole to DIN 332, sheet 2 / Zentrierung mit Gewinde DIN 332, Blatt 2

KR674.02

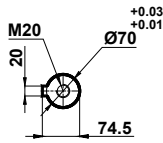
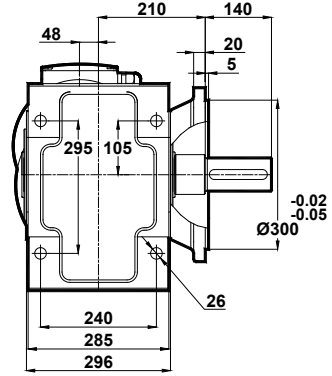
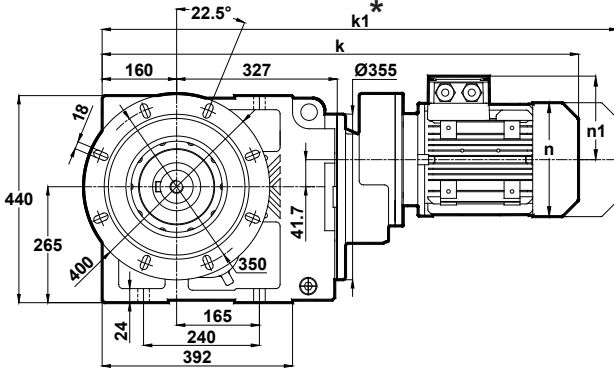

	80	90S	90L	100L
k	829.5	868.5	868.5	913.5
k1	922.5	972	972	1022
n	155	176	176	193
n1	123	132	132	149

Klemens Pozisyonları
Terminal Box Positions
Klemmenkasten Positionen

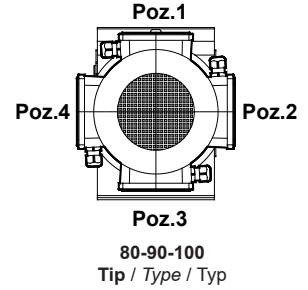

Opsiyonel flanş ölçüleri için sayfa 587'ye bakınız.
Please see on page 587 for optional flange dimensions
Siehe Seite 587 für auswählbare Flanschabmessungen

KR674.03

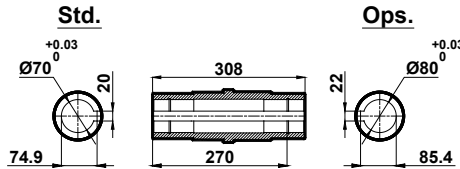
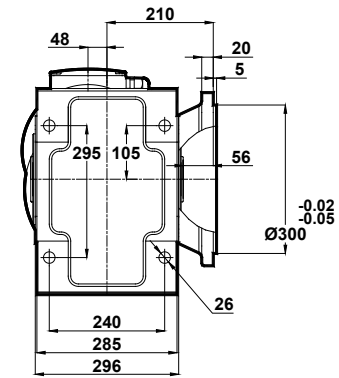
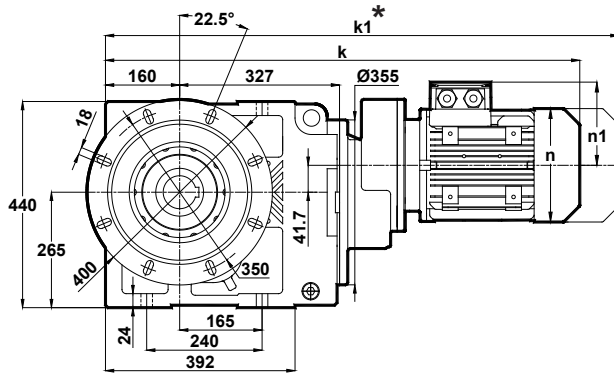

	80	90S	90L	100L
k	829.5	868.5	868.5	913.5
k1	922.5	972	972	1022
n	155	176	176	193
n1	123	132	132	149

Opsiyonel flanş ölçüleri için sayfa 587'ye bakınız.
Please see on page 587 for optional flange dimensions
Siehe Seite 587 für auswählbare Flanschabmessungen

* "k1" Ölçüsü frenli redüktörlere aittir.
Dimension "k1" is for motors with brake.
Maße "k1" ist für Bremsenmotoren.

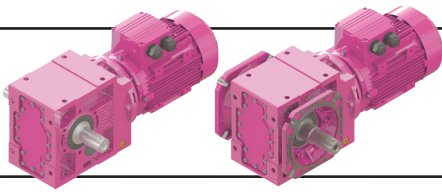

Ölçü Sayfaları

Dimension Pages

Abmessungsseiten

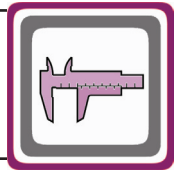

-Mil ucu çekirme deliği DIN 332 sayfa 2 / Tapped center hole to DIN 332, sheet 2 / Zentrierung mit Gewinde DIN 332, Blatt 2

KR674.04

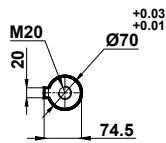
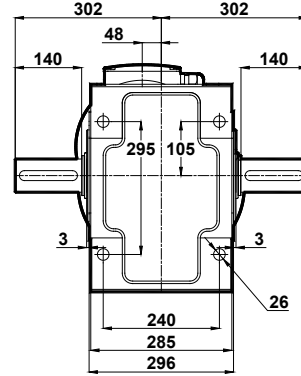
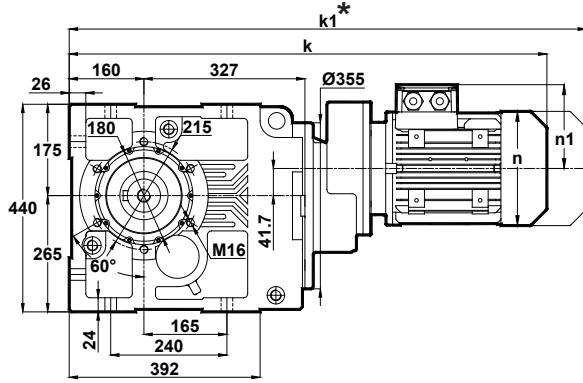

Klemens Pozisyonları
Terminal Box Positions
Klemmenkasten Positionen

	80	90S	90L	100L
k	829.5	868.5	868.5	913.5
k1	922.5	972	972	1022
n	155	176	176	193
n1	123	132	132	149

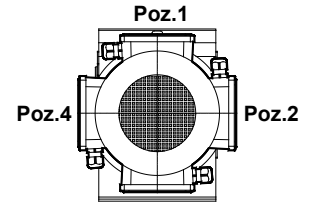

Poz.3

80-90-100

Tip / Type / Typ

KR674.05

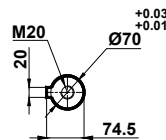
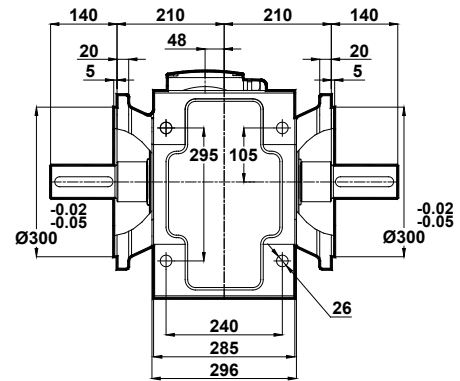
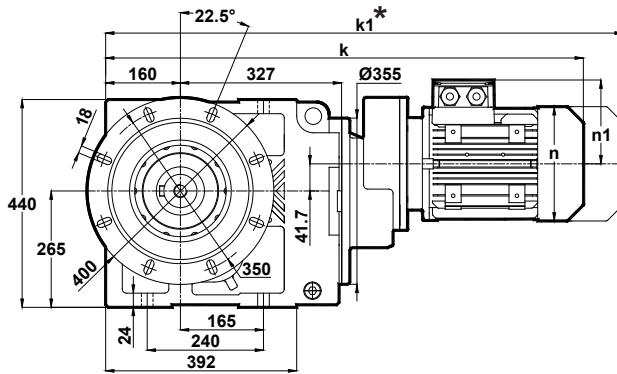

Opsiyonel flanş ölçüleri için sayfa 587'ye bakınız.
Please see on page 587 for optional flange dimensions
Siehe Seite 587 für auswählbare Flanschabmessungen

	80	90S	90L	100L
k	829.5	868.5	868.5	913.5
k1	922.5	972	972	1022
n	155	176	176	193
n1	123	132	132	149

* "k1" Ölçüsü frenli redüktörlere aittir.
Dimension "k1" is for motors with brake.
Maße "k1" ist für Bremsenmotoren.

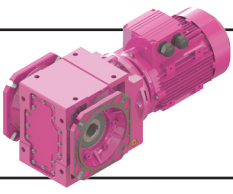

Ölçü Sayfaları Dimension Pages Abmessungsseiten

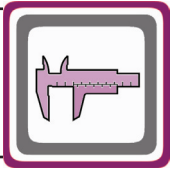

-Mil ucu çektirme deliği DIN 332 sayfa 2 / Tapped center hole to DIN 332, sheet 2 / Zentrierung mit Gewinde DIN 332, Blatt 2

KR674.08

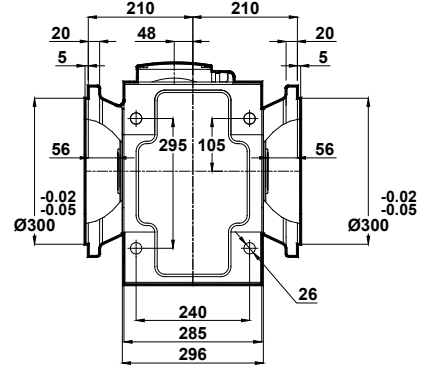
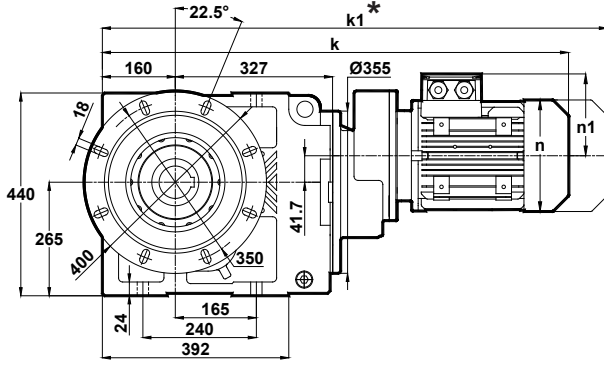

Std.

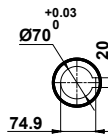

Ops.

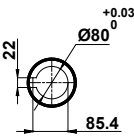

Klemens Pozisyonları
Terminal Box Positions
Klemmenkasten Positionen

	80	90S	90L	100L
k	829.5	868.5	868.5	913.5
k1	922.5	972	972	1022
n	155	176	176	193
n1	123	132	132	149

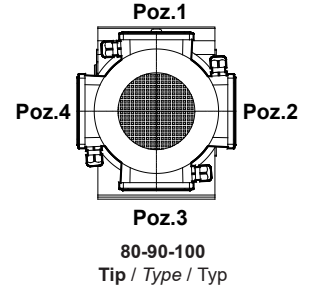

Opsiyonel flanş ölçüleri için sayfa 587'ye bakınız.
Please see on page 587 for optional flange dimensions
Siehe Seite 587 für auswählbare Flanschabmessungen

* "k1" Ölçüsü frenli redüktörlere aittir.
Dimension "k1" is for motors with brake.
Maße "k1" ist für Bremsenmotoren.

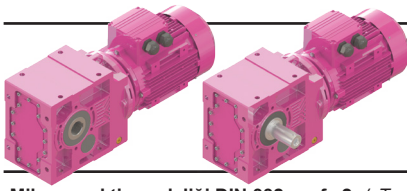

Ölçü Sayfaları

Dimension Pages

Abmessungsseiten

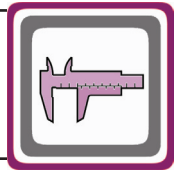

-Mil ucu çektirme deliği DIN 332 sayfa 2 / Tapped center hole to DIN 332, sheet 2 / Zentrierung mit Gewinde DIN 332, Blatt 2

KR675.00
KR676.00

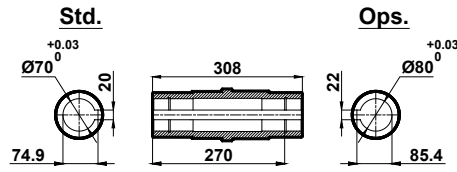
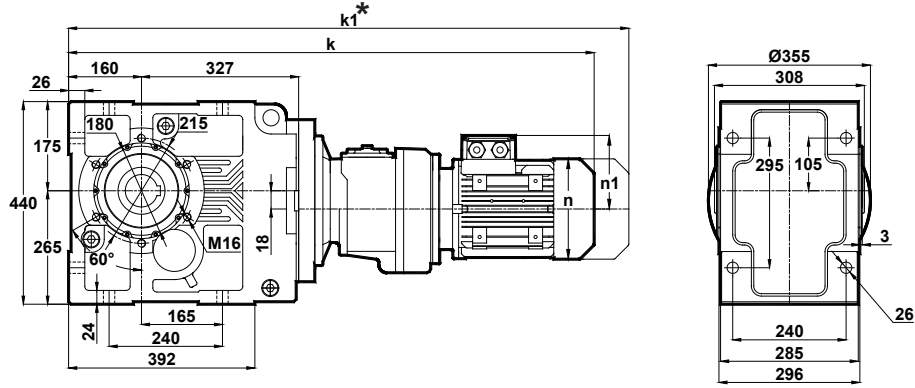

Klemens Pozisyonları
Terminal Box Positions
Klemmenkasten Positionen

	71	80	90S
k	941.5	975.5	1014.5
k1	1032.5	1068.5	1118
n	137	155	176
n1	112	123	132

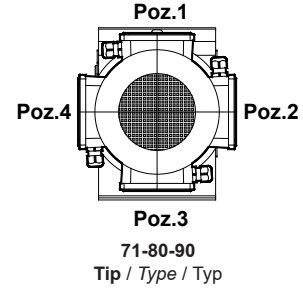

KR675.01
KR676.01

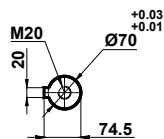
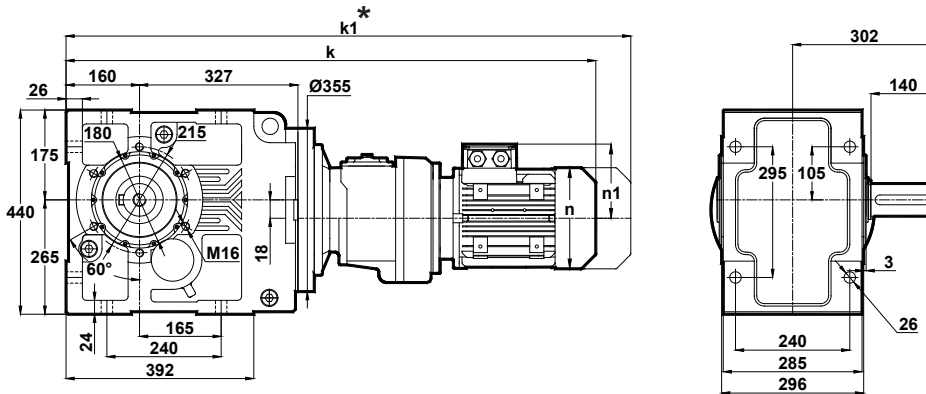

	71	80	90S
k	941.5	975.5	1014.5
k1	1032.5	1068.5	1118
n	137	155	176
n1	112	123	132

* "k1" Ölçüsü frenli redüktörlere aittir.
Dimension "k1" is for motors with brake.
Maße "k1" ist für Bremsenmotoren.

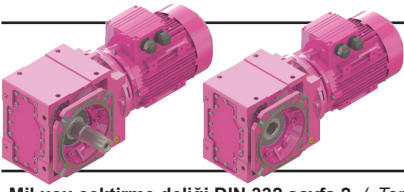

Ölçü Sayfaları Dimension Pages Abmessungenseiten

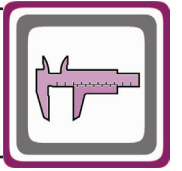

-Mil ucu çektirme deliği DIN 332 sayfa 2 / Tapped center hole to DIN 332, sheet 2 / Zentrierung mit Gewinde DIN 332, Blatt 2

KR675.02
KR676.02

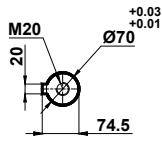
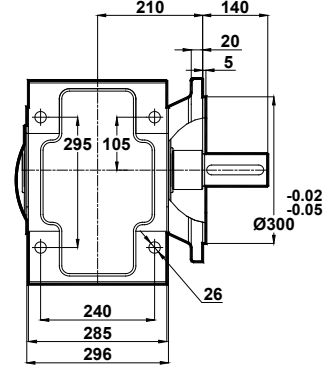
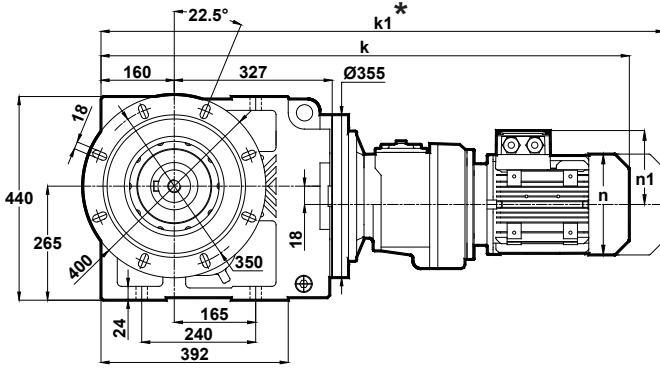

Klemens Pozisyonları
Terminal Box Positions
Klemmenkasten Positionen

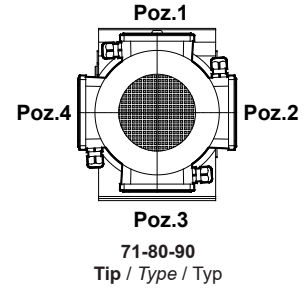

	71	80	90S
k	941.5	975.5	1014.5
k1	1032.5	1068.5	1118
n	137	155	176
n1	112	123	132

Opsiyonel flanş ölçüleri için sayfa 587'ye bakınız.
Please see on page 587 for optional flange dimensions
Siehe Seite 587 für auswählbare Flanschabmessungen

KR675.03
KR676.03

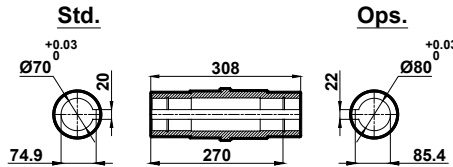
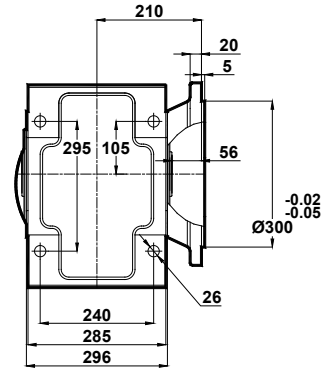
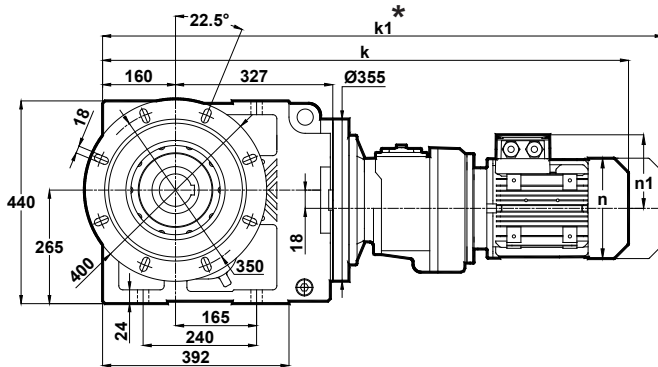

	71	80	90S
k	941.5	975.5	1014.5
k1	1032.5	1068.5	1118
n	137	155	176
n1	112	123	132

Opsiyonel flanş ölçüleri için sayfa 587'ye bakınız.
Please see on page 587 for optional flange dimensions
Siehe Seite 587 für auswählbare Flanschabmessungen

* " k1 " Ölçüsü frenli redüktörlere aittir.
Dimension " k1 " is for motors with brake.
Maße " k1 " ist für Bremsenmotoren.

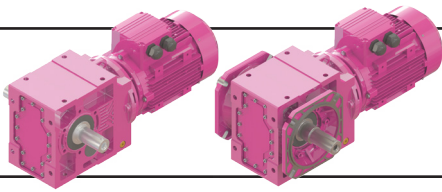

Ölçü Sayfaları Dimension Pages Abmessungsseiten

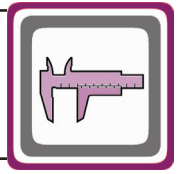

-Mil ucu çektirme deliği DIN 332 sayfa 2 / Tapped center hole to DIN 332, sheet 2 / Zentrierung mit Gewinde DIN 332, Blatt 2

KR675.04
KR676.04

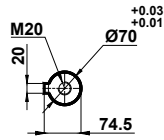
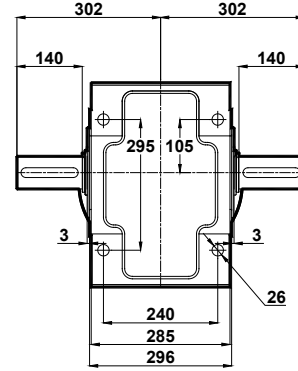
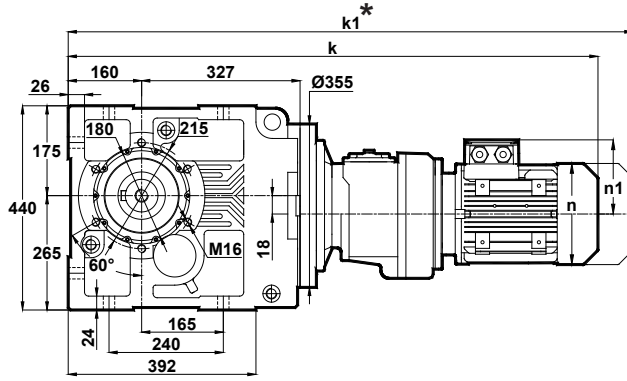

Klemens Pozisyonları
Terminal Box Positions
Klemmenkasten Positionen

	71	80	90S
k	941.5	975.5	1014.5
k1	1032.5	1068.5	1118
n	137	155	176
n1	112	123	132

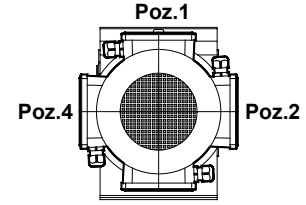

Poz.1
71-80-90
Tip / Type / Typ

KR675.05
KR676.05

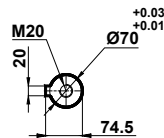
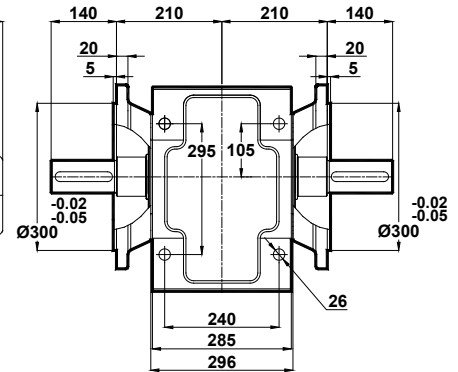
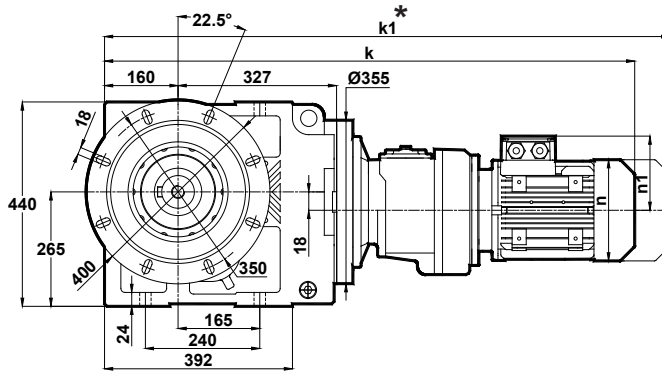

Opsiyonel flanş ölçüleri için sayfa 587'ye bakınız.
Please see on page 587 for optional flange dimensions
Siehe Seite 587 für auswählbare Flanschabmessungen

	71	80	90S
k	941.5	975.5	1014.5
k1	1032.5	1068.5	1118
n	137	155	176
n1	112	123	132

* "k1" Ölçüsü frenli redüktörlere aittir.
Dimension "k1" is for motors with brake.
Maße "k1" ist für Bremsenmotoren.

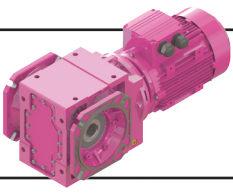

Ölçü Sayfaları Dimension Pages Abmessungsseiten

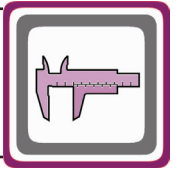

-Mil ucu çektirme deliği DIN 332 sayfa 2 / Tapped center hole to DIN 332, sheet 2 / Zentrierung mit Gewinde DIN 332, Blatt 2

KR675.08
KR676.08

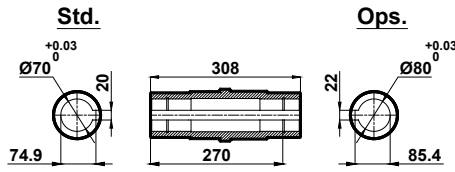
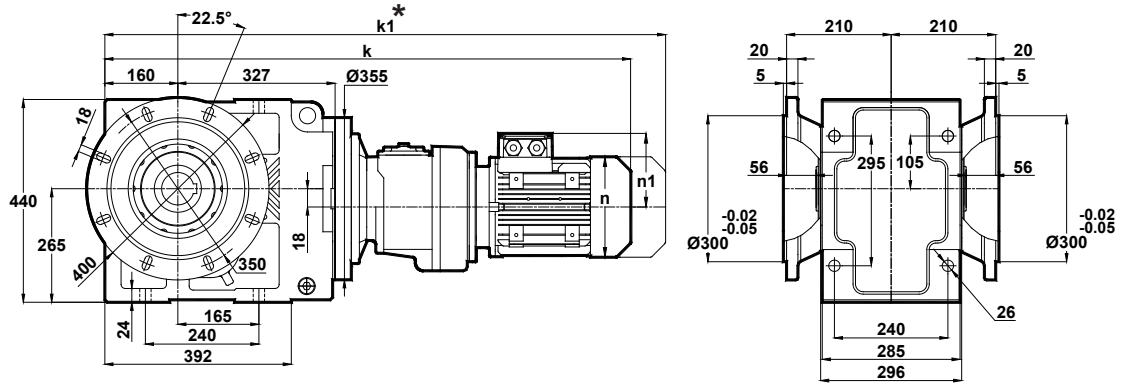

Klemens Pozisyonları
Terminal Box Positions
Klemmenkasten Positionen

	71	80	90S
k	941.5	975.5	1014.5
k1	1032.5	1068.5	1118
n	137	155	176
n1	112	123	132

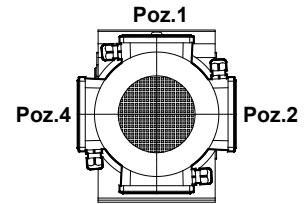

Poz.1
Poz.2
Poz.3
71-80-90
Tip / Type / Typ

Opsiyonel flanş ölçüleri için sayfa 587'ye bakınız.
Please see on page 587 for optional flange dimensions
Siehe Seite 587 für auswählbare Flanschabmessungen

* "k1" Ölçüsü frenli redüktörlere aittir.
Dimension "k1" is for motors with brake.
Maße "k1" ist für Bremsenmotoren.

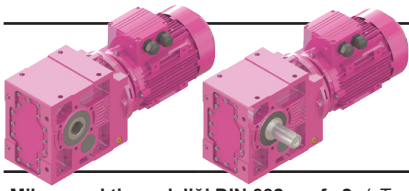

Ölçü Sayfaları

Dimension Pages

Abmessungsseiten

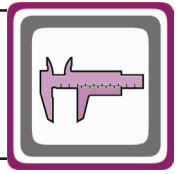

-Mil ucu çektirme deliği DIN 332 sayfa 2 / Tapped center hole to DIN 332, sheet 2 / Zentrierung mit Gewinde DIN 332, Blatt 2

KR773.00

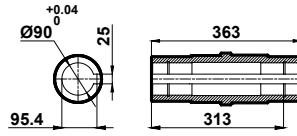
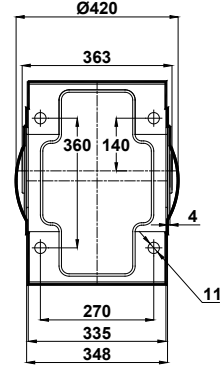
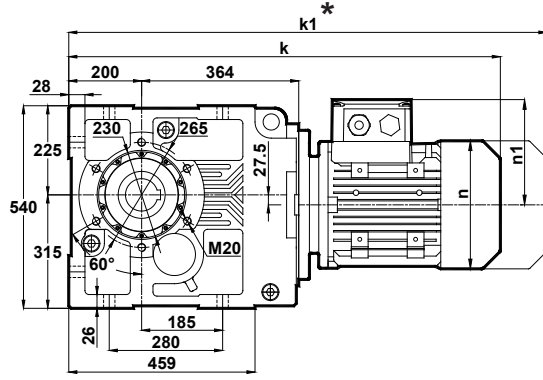

Klemens Pozisyonları
Terminal Box Positions
Klemmenkasten Positionen

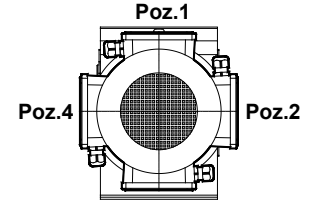

Poz.3
132-160-180-200-225-250
Tip / Type / Typ

	132S	132M	160M	160L	180M	180L	200L	225S	225M	250M
k	980.5	980.5	1076.5	1076.5	1148.5	1148.5	1194.5	1221.5	1246.5	1338.5
k1	1110.5	1110.5	1224.5	1224.5	1307	1307	1381	1386.5	1411.5	1509
n	257	257	316	316	348	348	396	438	438	481
n1	181	181	224	224	250	250	287	316	316	335

KR773.01

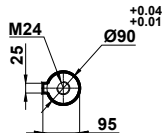
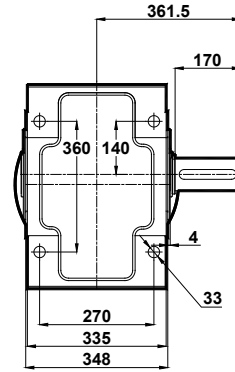
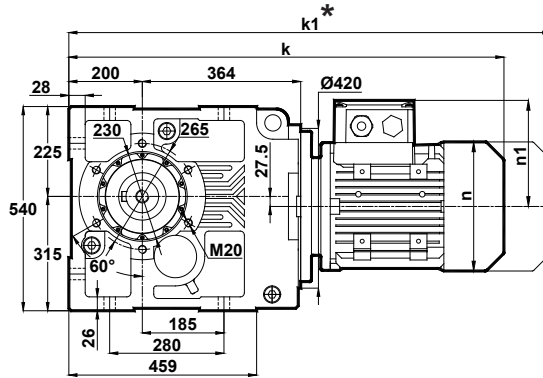

	132S	132M	160M	160L	180M	180L	200L	225S	225M	250M
k	980.5	980.5	1076.5	1076.5	1148.5	1148.5	1194.5	1221.5	1246.5	1338.5
k1	1110.5	1110.5	1224.5	1224.5	1307	1307	1381	1386.5	1411.5	1509
n	257	257	316	316	348	348	396	438	438	481
n1	181	181	224	224	250	250	287	316	316	335

* "k1" Ölçüsü frenli redüktörlere aittir.
Dimension "k1" is for motors with brake.
Maße "k1" ist für Bremsenmotoren.

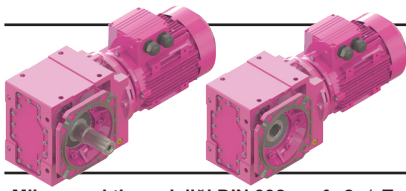

Ölçü Sayfaları Dimension Pages Abmessungenseiten

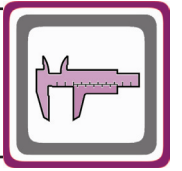

-Mil ucu çekirme deliği DIN 332 sayfa 2 / Tapped center hole to DIN 332, sheet 2 / Zentrierung mit Gewinde DIN 332, Blatt 2

KR773.02

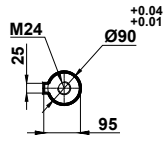
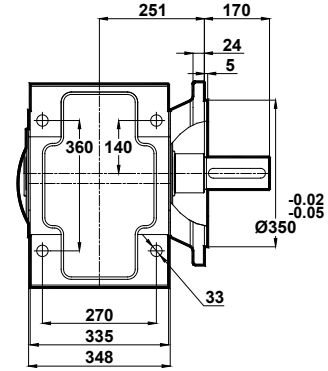
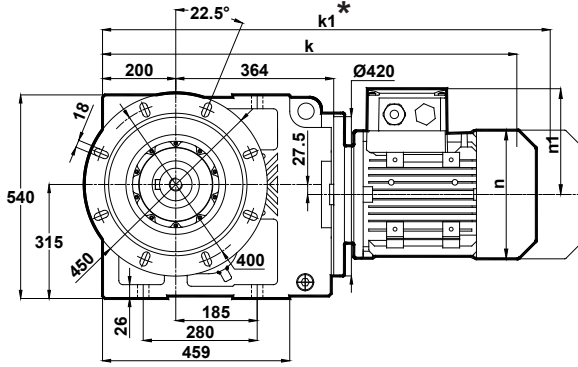

Klemens Pozisyonları
Terminal Box Positions
Klemmenkasten Positionen

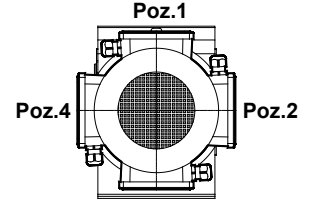

Poz.3
132-160-180-200-225-250
Tip / Type / Typ

	132S	132M	160M	160L	180M	180L	200L	225S	225M	250M
k	980.5	980.5	1076.5	1076.5	1148.5	1148.5	1194.5	1221.5	1246.5	1338.5
k1	1110.5	1110.5	1224.5	1224.5	1307	1307	1381	1386.5	1411.5	1509
n	257	257	316	316	348	348	396	438	438	481
n1	181	181	224	224	250	250	287	316	316	335

Opsiyonel flanş ölçüleri için sayfa 587'ye bakınız.
Please see on page 587 for optional flange dimensions
Siehe Seite 587 für auswählbare Flanschabmessungen

KR773.03

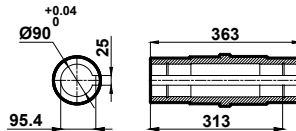
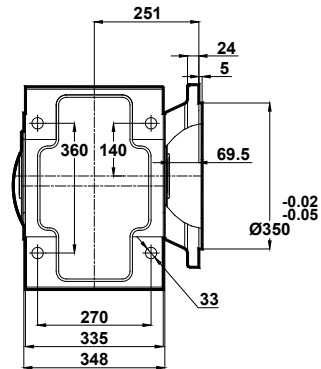
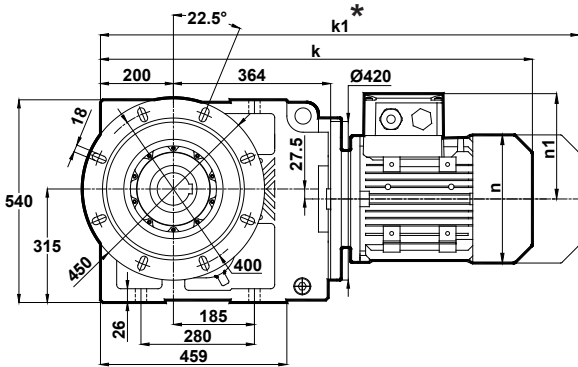

	132S	132M	160M	160L	180M	180L	200L	225S	225M	250M
k	980.5	980.5	1076.5	1076.5	1148.5	1148.5	1194.5	1221.5	1246.5	1338.5
k1	1110.5	1110.5	1224.5	1224.5	1307	1307	1381	1386.5	1411.5	1509
n	257	257	316	316	348	348	396	438	438	481
n1	181	181	224	224	250	250	287	316	316	335

Opsiyonel flanş ölçüleri için sayfa 587'ye bakınız.
Please see on page 587 for optional flange dimensions
Siehe Seite 587 für auswählbare Flanschabmessungen

* "k1" Ölçüsü frenli redüktörlere aittir.
Dimension "k1" is for motors with brake.
Maße "k1" ist für Bremsenmotoren.

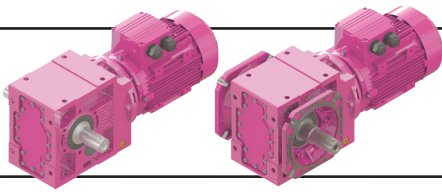

Ölçü Sayfaları Dimension Pages Abmessungsseiten

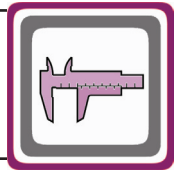

-Mil ucu çektirme deliği DIN 332 sayfa 2 / Tapped center hole to DIN 332, sheet 2 / Zentrierung mit Gewinde DIN 332, Blatt 2

KR773.04

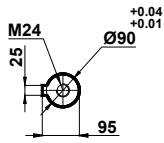
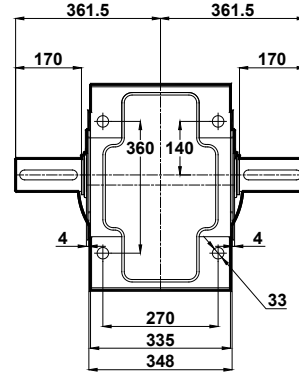
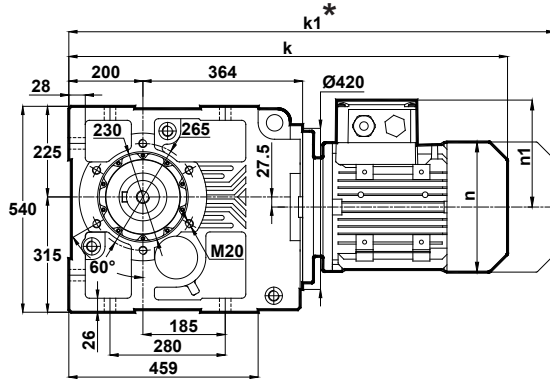

Klemens Pozisyonları
Terminal Box Positions
Klemmenkasten Positionen

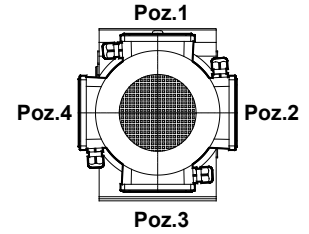

132-160-180-200-225-250
Tip / Type / Typ

	132S	132M	160M	160L	180M	180L	200L	225S	225M	250M
k	980.5	980.5	1076.5	1076.5	1148.5	1148.5	1194.5	1221.5	1246.5	1338.5
k1	1110.5	1110.5	1224.5	1224.5	1307	1307	1381	1386.5	1411.5	1509
n	257	257	316	316	348	348	396	438	438	481
n1	181	181	224	224	250	250	287	316	316	335

KR773.05

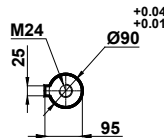
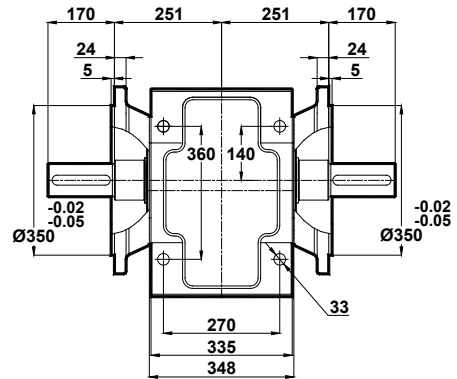
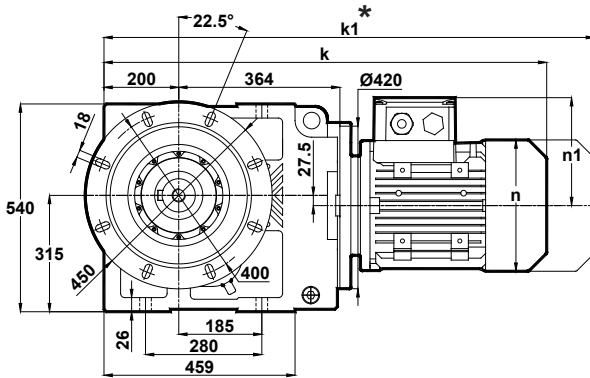

Opsiyonel flanş ölçüleri için sayfa 587'ye bakınız.
Please see on page 587 for optional flange dimensions
Siehe Seite 587 für auswählbare Flanschabmessungen

	132S	132M	160M	160L	180M	180L	200L	225S	225M	250M
k	980.5	980.5	1076.5	1076.5	1148.5	1148.5	1194.5	1221.5	1246.5	1338.5
k1	1110.5	1110.5	1224.5	1224.5	1307	1307	1381	1386.5	1411.5	1509
n	257	257	316	316	348	348	396	438	438	481
n1	181	181	224	224	250	250	287	316	316	335

* "k1" Ölçüsü frenli redüktörlere aittir.
Dimension "k1" is for motors with brake.
Maße "k1" ist für Bremsenmotoren.

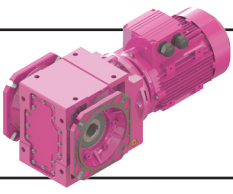

Ölçü Sayfaları Dimension Pages Abmessungenseiten

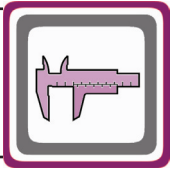

-Mil ucu çektirme deliği DIN 332 sayfa 2 / Tapped center hole to DIN 332, sheet 2 / Zentrierung mit Gewinde DIN 332, Blatt 2

KR773.08

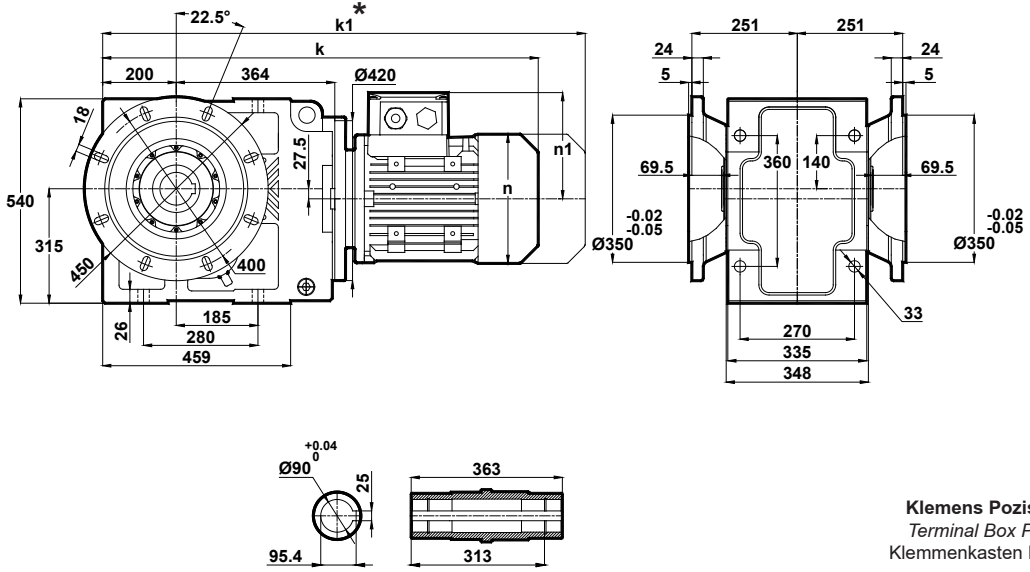

Klemens Pozisyonları
Terminal Box Positions
Klemmenkasten Positionen

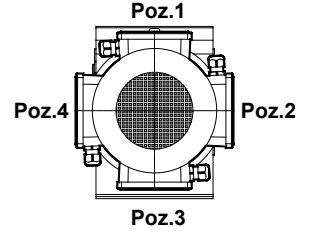

132-160-180-200-225-250
Tip / Type / Typ

	132S	132M	160M	160L	180M	180L	200L	225S	225M	250M
k	980.5	980.5	1076.5	1076.5	1148.5	1148.5	1194.5	1221.5	1246.5	1338.5
k1	1110.5	1110.5	1224.5	1224.5	1307	1307	1381	1386.5	1411.5	1509
n	257	257	316	316	348	348	396	438	438	481
n1	181	181	224	224	250	250	287	316	316	335

Opsiyonel flanş ölçüleri için sayfa 587'ye bakınız.
Please see on page 587 for optional flange dimensions
Siehe Seite 587 für auswählbare Flanschabmessungen

* "k1" Ölçüsü frenli redüktörlere aittir.
Dimension "k1" is for motors with brake.
Maße "k1" ist für Bremsenmotoren.

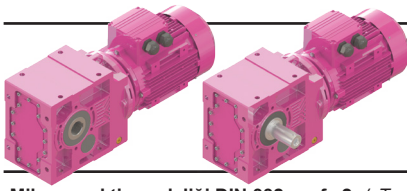

Ölçü Sayfaları

Dimension Pages

Abmessungsseiten

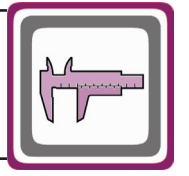

-Mil ucu çekirme deliği DIN 332 sayfa 2 / Tapped center hole to DIN 332, sheet 2 / Zentrierung mit Gewinde DIN 332, Blatt 2

KR774.00

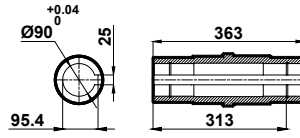
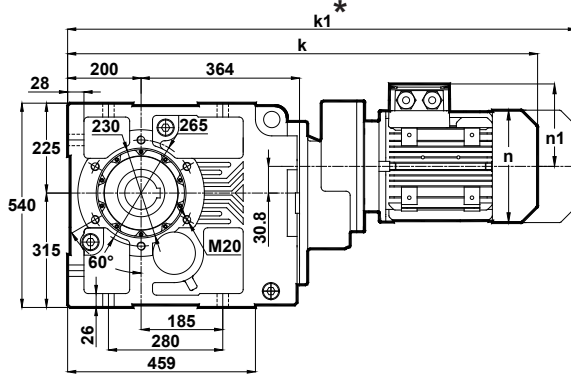

Klemens Pozisyonları
Terminal Box Positions
Klemmenkasten Positionen

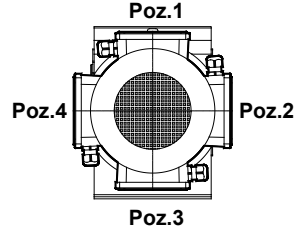

90-100-112-132
Tip / Type / Typ

	90S	90L	100L	112M	132S	132M
k	945.5	945.5	990.5	1014.5	1099.5	1099.5
k1	1049	1049	1099	1119	1229.5	1229.5
n	176	176	193	215	257	257
n1	132	132	149	161	181	181

KR774.01

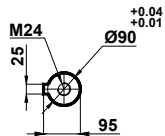
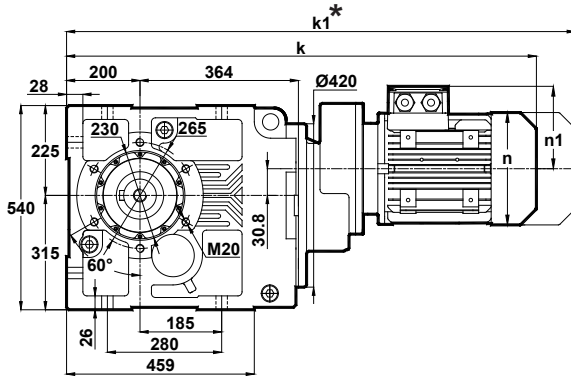

	90S	90L	100L	112M	132S	132M
k	945.5	945.5	990.5	1014.5	1099.5	1099.5
k1	1049	1049	1099	1119	1229.5	1229.5
n	176	176	193	215	257	257
n1	132	132	149	161	181	181

* "k1" Ölçüsü frenli redüktörlere aittir.
Dimension "k1" is for motors with brake.
Maße "k1" ist für Bremsenmotoren.

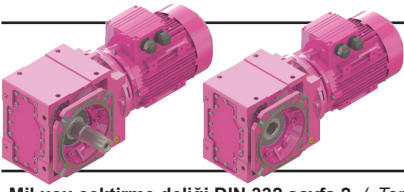

Ölçü Sayfaları Dimension Pages Abmessungsseiten

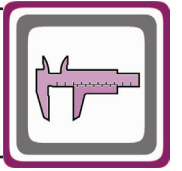

-Mil ucu çektirme deliği DIN 332 sayfa 2 / Tapped center hole to DIN 332, sheet 2 / Zentrierung mit Gewinde DIN 332, Blatt 2

KR774.02

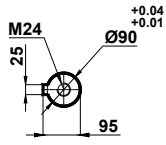
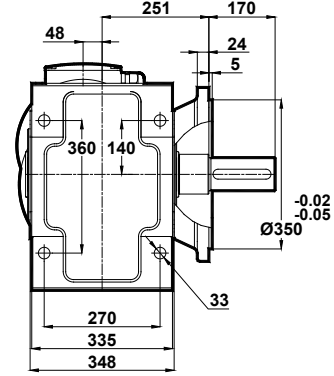
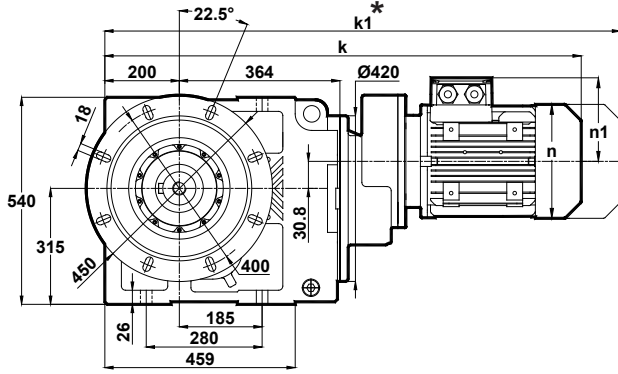

Klemens Pozisyonları
Terminal Box Positions
Klemmenkasten Positionen

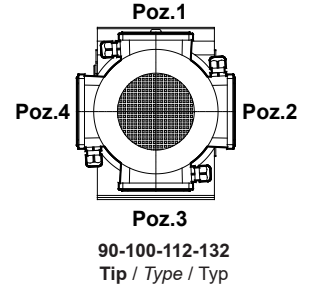

	90S	90L	100L	112M	132S	132M
k	945.5	945.5	990.5	1014.5	1099.5	1099.5
k1	1049	1049	1099	1119	1229.5	1229.5
n	176	176	193	215	257	257
n1	132	132	149	161	181	181

Opsiyonel flanş ölçüleri için sayfa 587'ye bakınız.
Please see on page 587 for optional flange dimensions
Siehe Seite 587 für auswählbare Flanschabmessungen

KR774.03

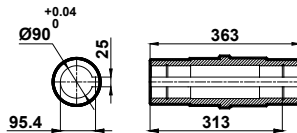
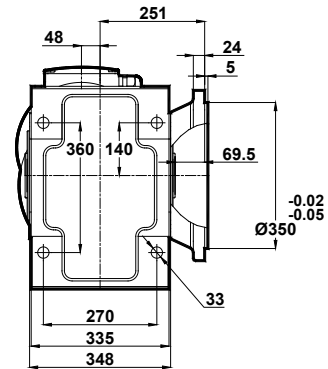
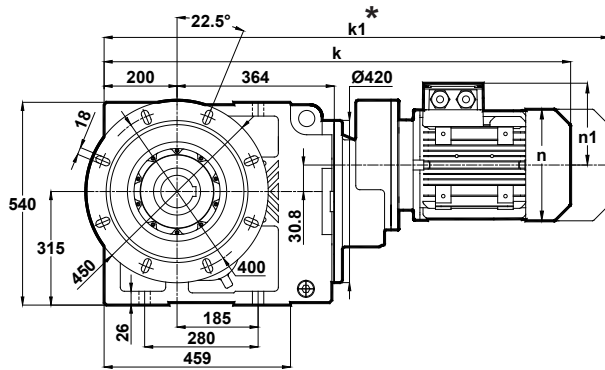

	90S	90L	100L	112M	132S	132M
k	945.5	945.5	990.5	1014.5	1099.5	1099.5
k1	1049	1049	1099	1119	1229.5	1229.5
n	176	176	193	215	257	257
n1	132	132	149	161	181	181

Opsiyonel flanş ölçüleri için sayfa 587'ye bakınız.
Please see on page 587 for optional flange dimensions
Siehe Seite 587 für auswählbare Flanschabmessungen

* " k1 " Ölçüsü frenli redüktörlere aittir.
Dimension " k1 " is for motors with brake.
Maße " k1 " ist für Bremsenmotoren.

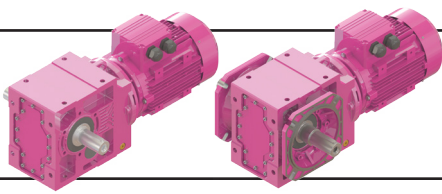

Ölçü Sayfaları Dimension Pages Abmessungsseiten

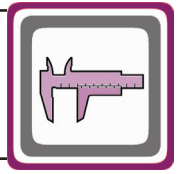

-Mil ucu çekirme deliği DIN 332 sayfa 2 / Tapped center hole to DIN 332, sheet 2 / Zentrierung mit Gewinde DIN 332, Blatt 2

KR774.04

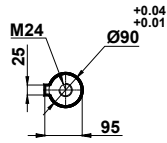
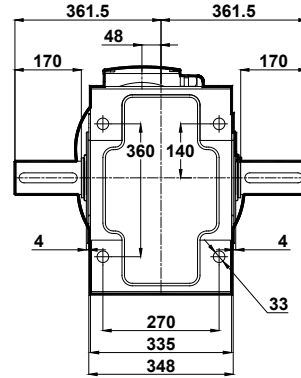
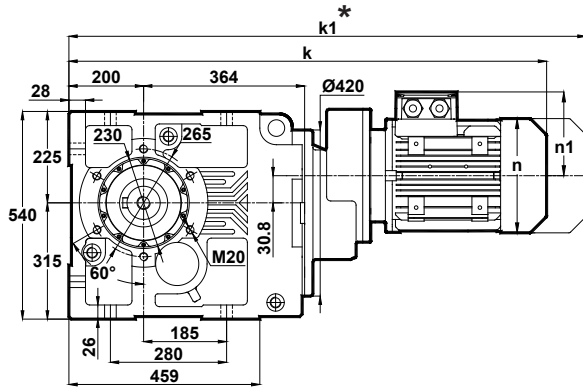

Klemens Pozisyonları
Terminal Box Positions
Klemmenkasten Positionen

	90S	90L	100L	112M	132S	132M
k	945.5	945.5	990.5	1014.5	1099.5	1099.5
k1	1049	1049	1099	1119	1229.5	1229.5
n	176	176	193	215	257	257
n1	132	132	149	161	181	181

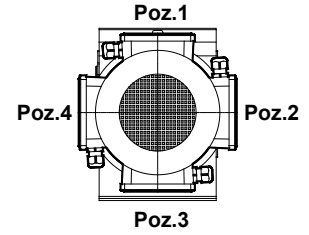

90-100-112-132
Tip / Type / Typ

KR774.05

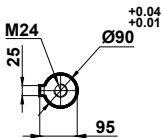
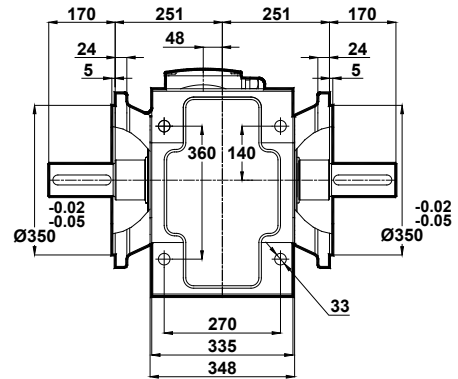
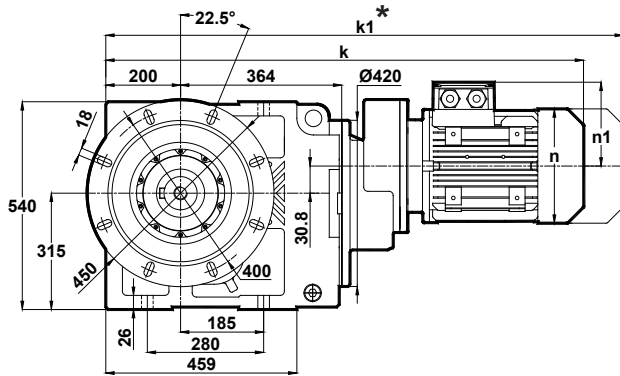

Opsiyonel flanş ölçüleri için sayfa 587'ye bakınız.
Please see on page 587 for optional flange dimensions
Siehe Seite 587 für auswählbare Flanschabmessungen

	90S	90L	100L	112M	132S	132M
k	945.5	945.5	990.5	1014.5	1099.5	1099.5
k1	1049	1049	1099	1119	1229.5	1229.5
n	176	176	193	215	257	257
n1	132	132	149	161	181	181

* "k1" Ölçüsü frenli redüktörlere aittir.
Dimension "k1" is for motors with brake.
Maße "k1" ist für Bremsenmotoren.

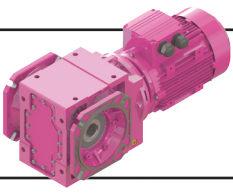

Ölçü Sayfaları Dimension Pages Abmessungsseiten

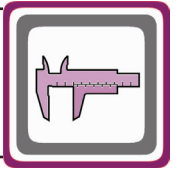

-Mil ucu çektirme deliği DIN 332 sayfa 2 / Tapped center hole to DIN 332, sheet 2 / Zentrierung mit Gewinde DIN 332, Blatt 2

KR774.08

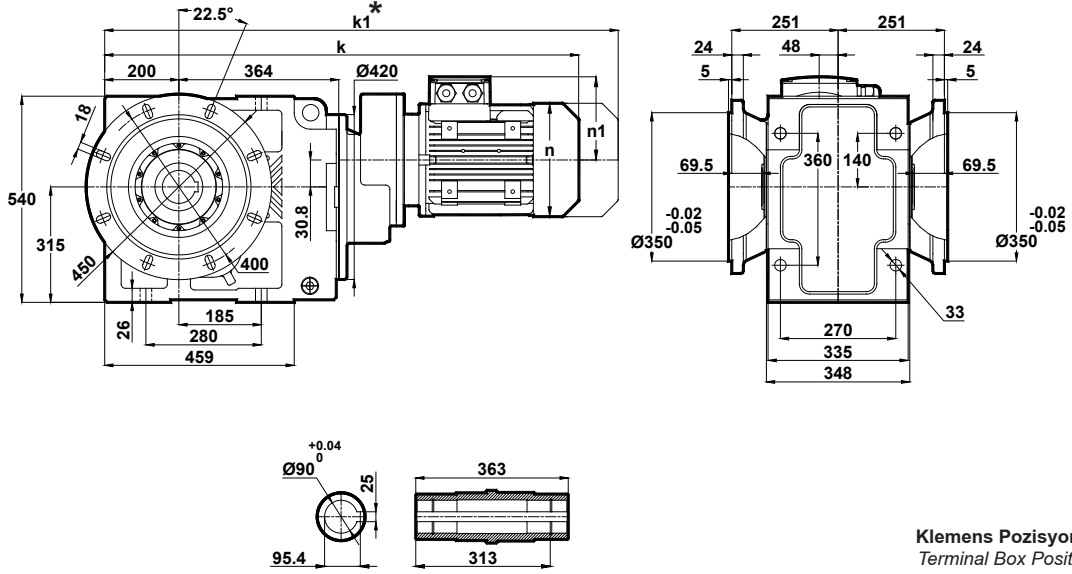

	90S	90L	100L	112M	132S	132M
k	945.5	945.5	990.5	1014.5	1099.5	1099.5
k1	1049	1049	1099	1119	1229.5	1229.5
n	176	176	193	215	257	257
n1	132	132	149	161	181	181

Klemens Pozisyonları
Terminal Box Positions
Klemmenkasten Positionen

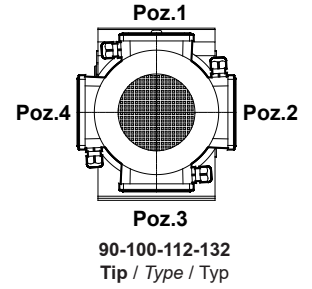

Opsiyonel flanş ölçüleri için sayfa 587'ye bakınız.
Please see on page 587 for optional flange dimensions
Siehe Seite 587 für auswählbare Flanschabmessungen

* "k1" Ölçüsü frenli redüktörlere aittir.
Dimension "k1" is for motors with brake.
Maße "k1" ist für Bremsenmotoren.

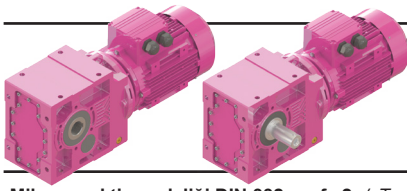

Ölçü Sayfaları

Dimension Pages

Abmessungsseiten

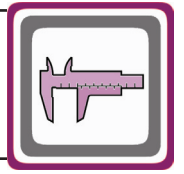

-Mil ucu çekirme deliği DIN 332 sayfa 2 / Tapped center hole to DIN 332, sheet 2 / Zentrierung mit Gewinde DIN 332, Blatt 2

KR775.00
KR776.00

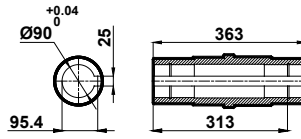
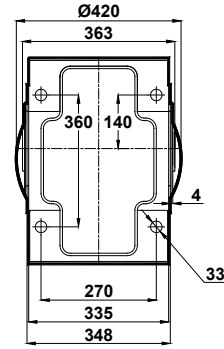
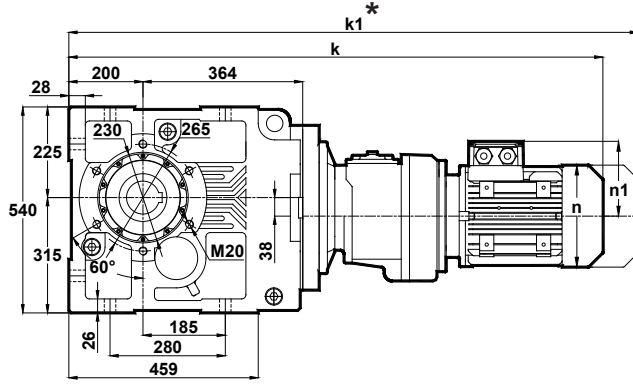

Klemens Pozisyonları
Terminal Box Positions
Klemmenkasten Positionen

	71	80	90S	90L	100L
k	1018.5	1052.5	1091.5	1091.5	1139.5
k1	1109.5	1145.5	1195	1195	1248
n	137	155	176	176	193
n1	112	123	132	132	149

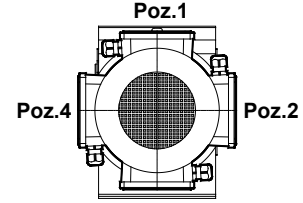

Poz.3
71-80-90-100
Tip / Type / Typ

KR775.01
KR776.01

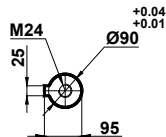
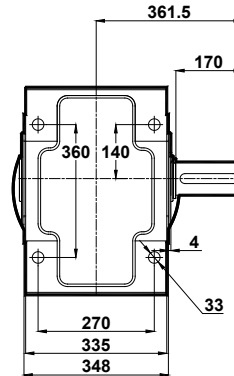
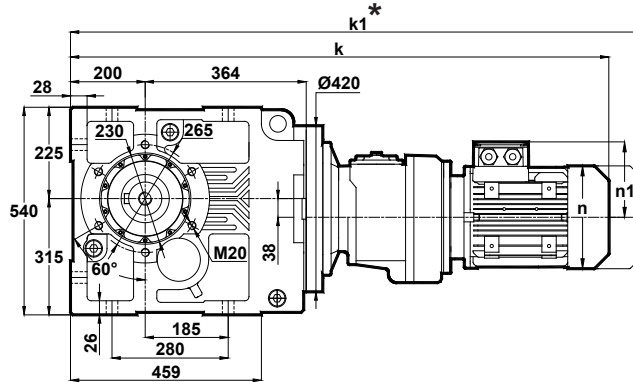

	71	80	90S	90L	100L
k	1018.5	1052.5	1091.5	1091.5	1139.5
k1	1109.5	1145.5	1195	1195	1248
n	137	155	176	176	193
n1	112	123	132	132	149

* "k1" Ölçüsü frenli redüktörlere aittir.
Dimension "k1" is for motors with brake.
Maße "k1" ist für Bremsenmotoren.

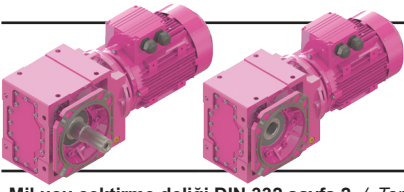

Ölçü Sayfaları

Dimension Pages

Abmessungsseiten

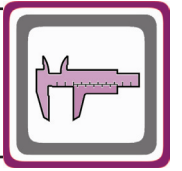

-Mil ucu çektirme deliği DIN 332 sayfa 2 / Tapped center hole to DIN 332, sheet 2 / Zentrierung mit Gewinde DIN 332, Blatt 2

KR775.02
KR776.02

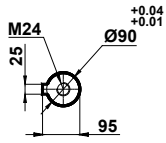
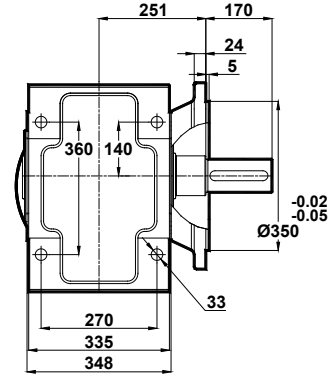
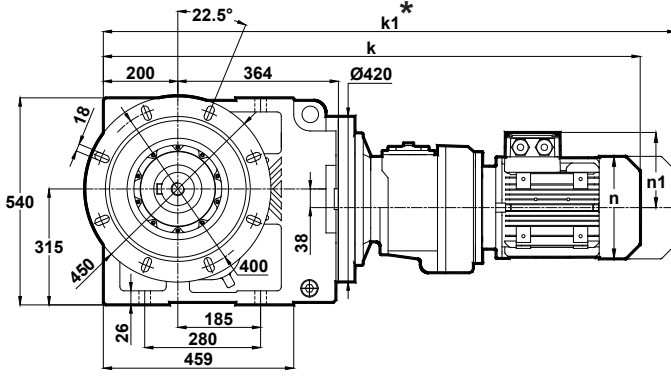

Klemens Pozisyonları
Terminal Box Positions
Klemmenkasten Positionen

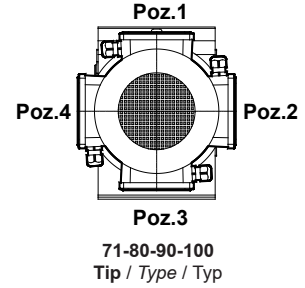

	71	80	90S	90L	100L
k	1018.5	1052.5	1091.5	1091.5	1139.5
k1	1109.5	1145.5	1195	1195	1248
n	137	155	176	176	193
n1	112	123	132	132	149

Opsiyonel flanş ölçüleri için sayfa 587'ye bakınız.
Please see on page 587 for optional flange dimensions
Siehe Seite 587 für auswählbare Flanschabmessungen

KR775.03
KR776.03

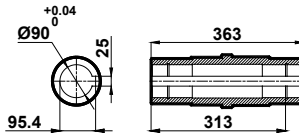
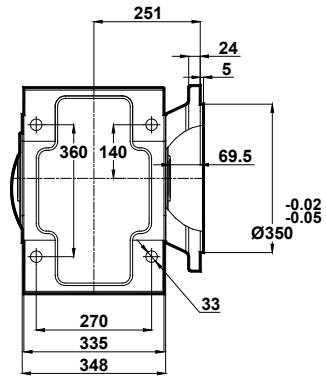
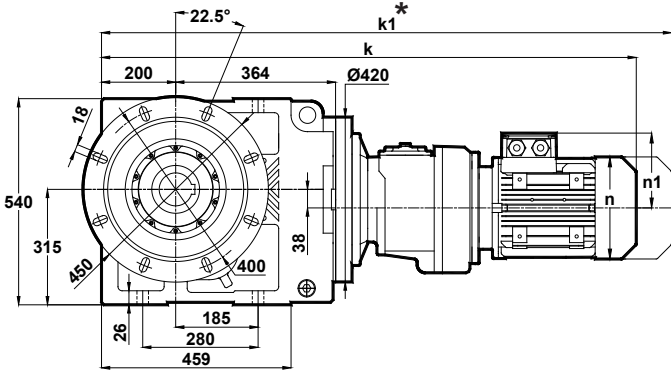

	71	80	90S	90L	100L
k	1018.5	1052.5	1091.5	1091.5	1139.5
k1	1109.5	1145.5	1195	1195	1248
n	137	155	176	176	193
n1	112	123	132	132	149

Opsiyonel flanş ölçüleri için sayfa 587'ye bakınız.
Please see on page 587 for optional flange dimensions
Siehe Seite 587 für auswählbare Flanschabmessungen

* " k1 " Ölçüsü frenli redüktörlere aittir.
Dimension " k1 " is for motors with brake.
Maße " k1 " ist für Bremsenmotoren.

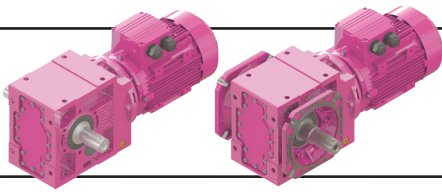

Ölçü Sayfaları Dimension Pages Abmessungsseiten

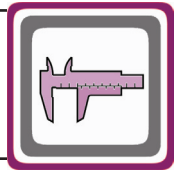

-Mil ucu çektirme deliği DIN 332 sayfa 2 / Tapped center hole to DIN 332, sheet 2 / Zentrierung mit Gewinde DIN 332, Blatt 2

KR775.04
KR776.04

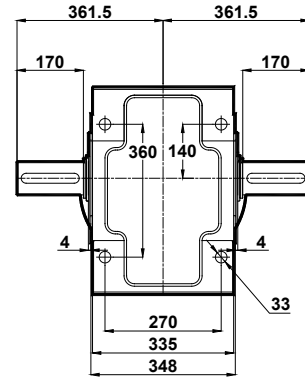
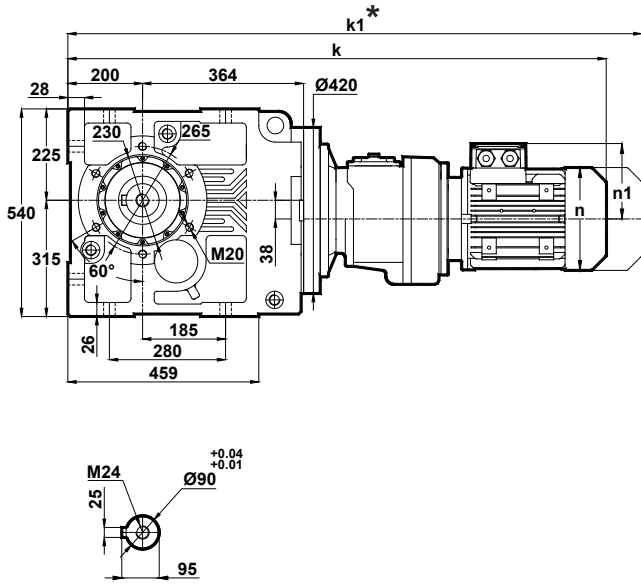

Klemens Pozisyonları
Terminal Box Positions
Klemmenkasten Positionen

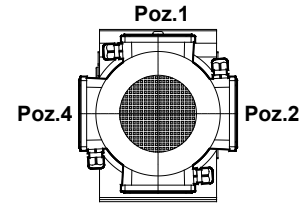

Poz.3

71-80-90-100
Tip / Type / Typ

	71	80	90S	90L	100L
k	1018.5	1052.5	1091.5	1091.5	1139.5
k1	1109.5	1145.5	1195	1195	1248
n	137	155	176	176	193
n1	112	123	132	132	149

KR775.05
KR776.05

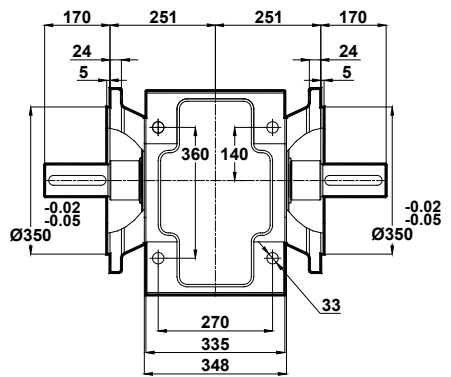
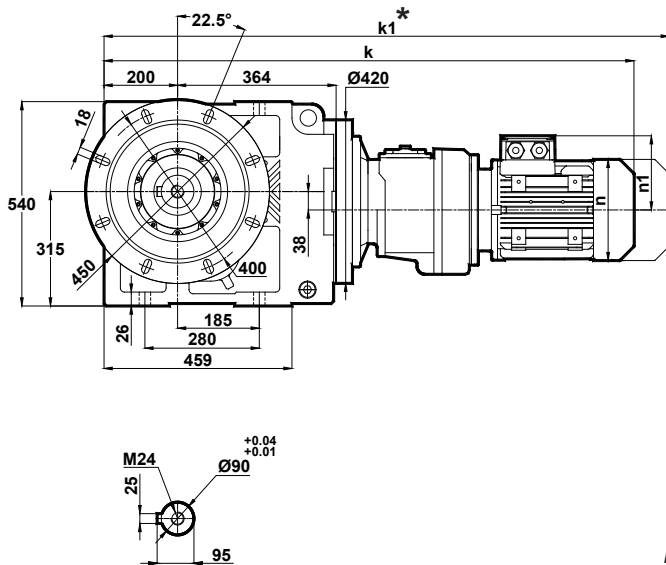

Opsiyonel flanş ölçüleri için sayfa 587'ye bakınız.
Please see on page 587 for optional flange dimensions
Siehe Seite 587 für auswählbare Flanschabmessungen

	71	80	90S	90L	100L
k	1018.5	1052.5	1091.5	1091.5	1139.5
k1	1109.5	1145.5	1195	1195	1248
n	137	155	176	176	193
n1	112	123	132	132	149

* "k1" Ölçüsü frenli redüktörlere aittir.
Dimension "k1" is for motors with brake.
Maße "k1" ist für Bremsenmotoren.

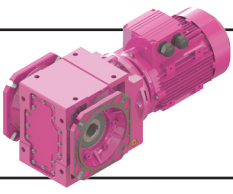

Ölçü Sayfaları Dimension Pages Abmessungsseiten

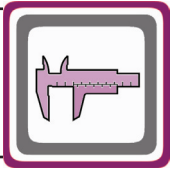

-Mil ucu çektirme deliği DIN 332 sayfa 2 / Tapped center hole to DIN 332, sheet 2 / Zentrierung mit Gewinde DIN 332, Blatt 2

KR775.08
KR776.08

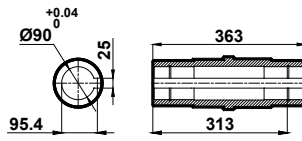
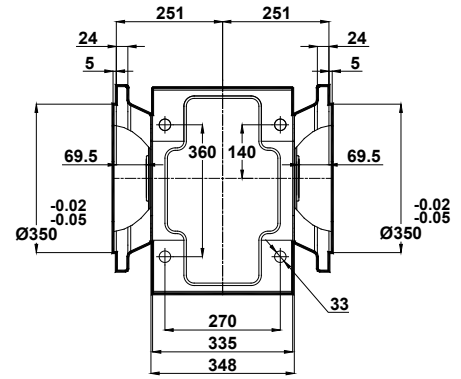
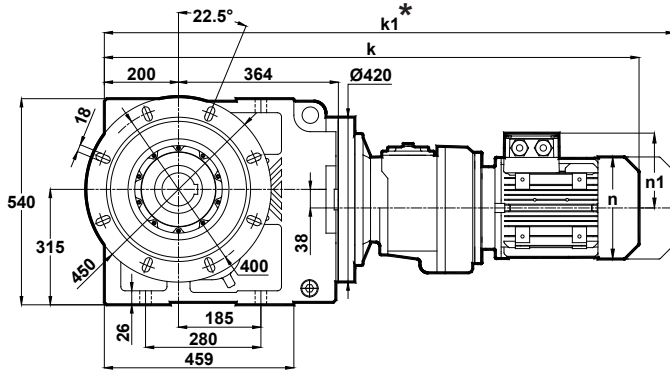

Klemens Pozisyonları
Terminal Box Positions
Klemmenkasten Positionen

	71	80	90S	90L	100L
k	1018.5	1052.5	1091.5	1091.5	1139.5
k1	1109.5	1145.5	1195	1195	1248
n	137	155	176	176	193
n1	112	123	132	132	149

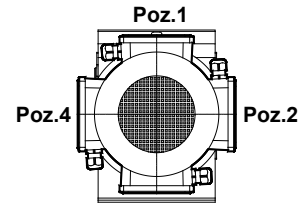

Poz.3

71-80-90-100
Tip / Type / Typ

Opsiyonel flanş ölçüleri için sayfa 587'ye bakınız.
Please see on page 587 for optional flange dimensions
Siehe Seite 587 für auswählbare Flanschabmessungen

* "k1" Ölçüsü frenli redüktörlere aittir.
Dimension "k1" is for motors with brake.
Maße "k1" ist für Bremsenmotoren.

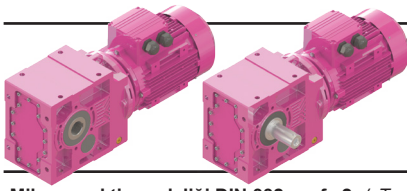

Ölçü Sayfaları

Dimension Pages

Abmessungsseiten

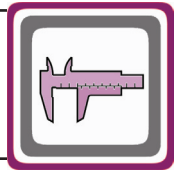

-Mil ucu çektirme deliği DIN 332 sayfa 2 / Tapped center hole to DIN 332, sheet 2 / Zentrierung mit Gewinde DIN 332, Blatt 2

KR873.00

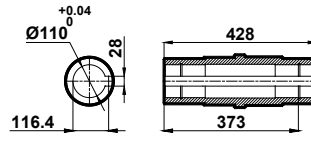
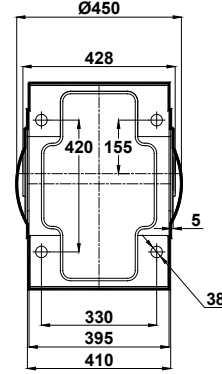
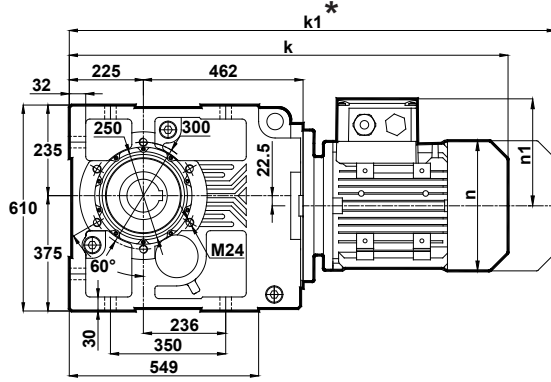

Klemens Pozisyonları
Terminal Box Positions
Klemmenkasten Positionen

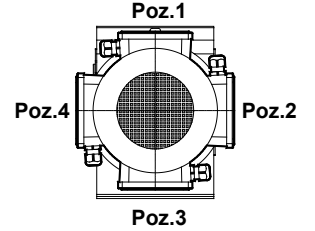

132-160-180-200-225-250-280
Tip / Type / Typ

	160M	160L	180M	180L	200L	225S	225M	250M	280S	280M
k	1187.5	1187.5	1259.5	1259.5	1305.5	1335	1360	1450.5	1512.5	1512.5
k1	1335.5	1335.5	1418	1418	1492	1500	1525	1621	1685.5	1691.5
n	316	316	348	348	396	438	438	481	547	547
n1	224	224	250	250	287	316	316	335	402	402

KR873.01

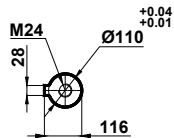
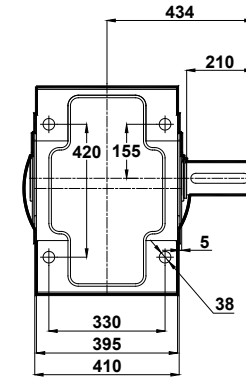
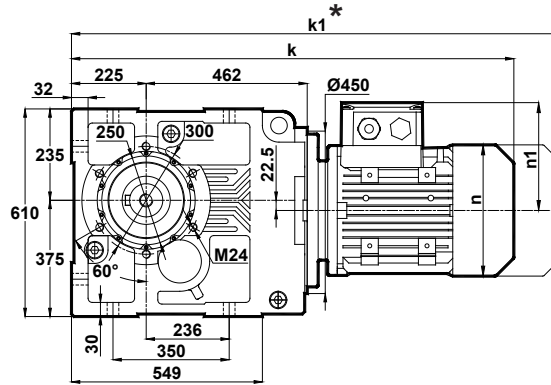

	160M	160L	180M	180L	200L	225S	225M	250M	280S	280M
k	1187.5	1187.5	1259.5	1259.5	1305.5	1335	1360	1450.5	1512.5	1512.5
k1	1335.5	1335.5	1418	1418	1492	1500	1525	1621	1685.5	1691.5
n	316	316	348	348	396	438	438	481	547	547
n1	224	224	250	250	287	316	316	335	402	402

* "k1" Ölçüsü frenli redüktörlere aittir.
Dimension "k1" is for motors with brake.
Maße "k1" ist für Bremsenmotoren.

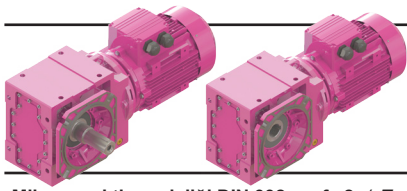

Ölçü Sayfaları

Dimension Pages

Abmessungsseiten

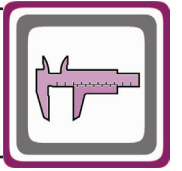

-Mil ucu çektirme deliği DIN 332 sayfa 2 / Tapped center hole to DIN 332, sheet 2 / Zentrierung mit Gewinde DIN 332, Blatt 2

KR873.02

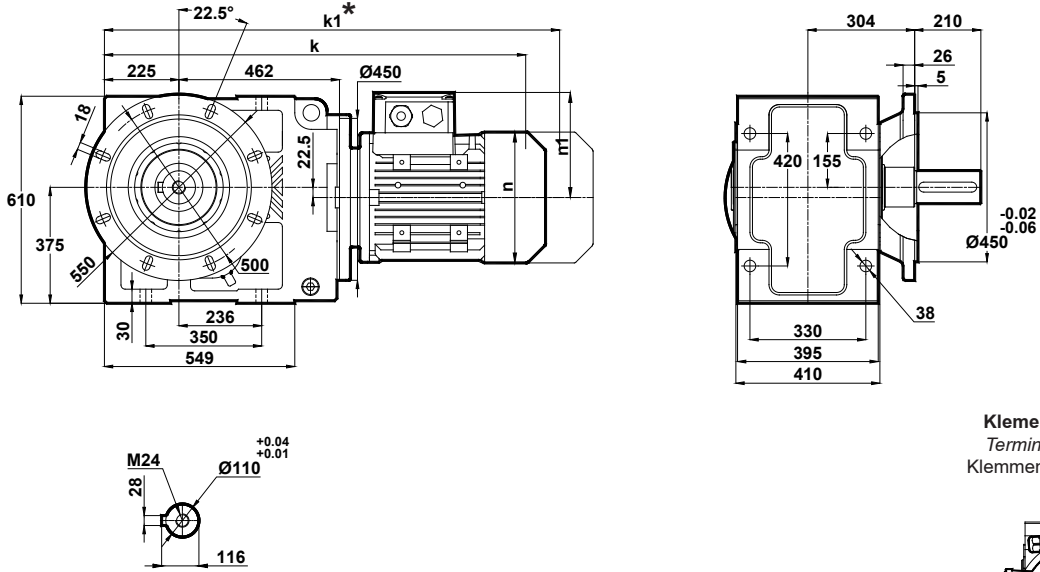

Klemens Pozisyonları
Terminal Box Positions
Klemmenkasten Positionen

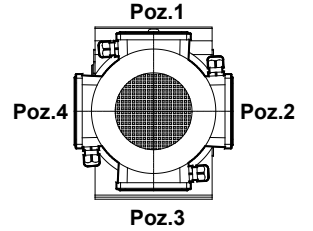

132-160-180-200-225-250-280
Tip / Type / Typ

	160M	160L	180M	180L	200L	225S	225M	250M	280S	280M
k	1187.5	1187.5	1259.5	1259.5	1305.5	1335	1360	1450.5	1512.5	1512.5
k1	1335.5	1335.5	1418	1418	1492	1500	1525	1621	1685.5	1691.5
n	316	316	348	348	396	438	438	481	547	547
n1	224	224	250	250	287	316	316	335	402	402

Opsiyonel flanş ölçüleri için sayfa 587'ye bakınız.
Please see on page 587 for optional flange dimensions
Siehe Seite 587 für auswählbare Flanschabmessungen

KR873.03

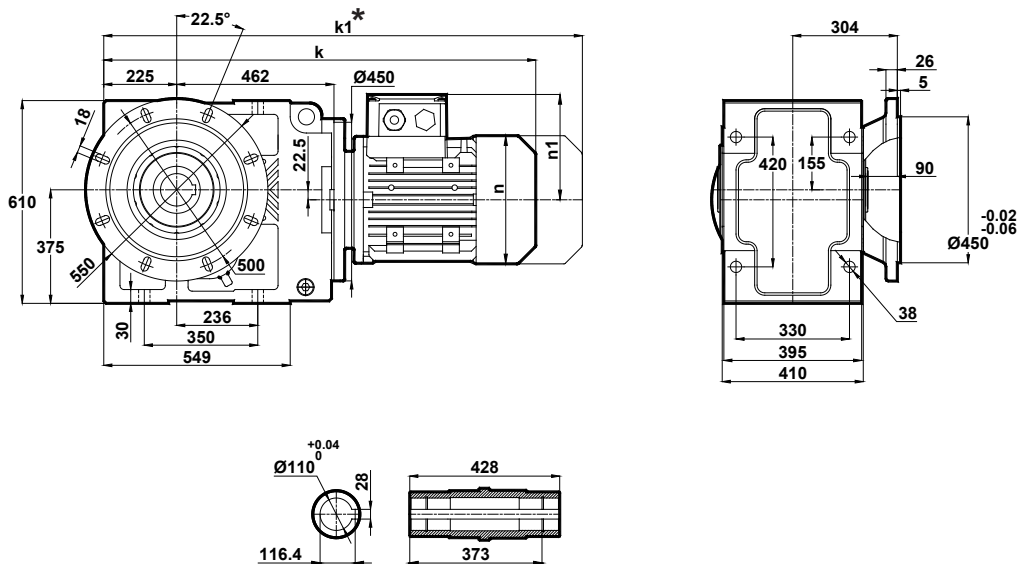

	160M	160L	180M	180L	200L	225S	225M	250M	280S	280M
k	1187.5	1187.5	1259.5	1259.5	1305.5	1335	1360	1450.5	1512.5	1512.5
k1	1335.5	1335.5	1418	1418	1492	1500	1525	1621	1685.5	1691.5
n	316	316	348	348	396	438	438	481	547	547
n1	224	224	250	250	287	316	316	335	402	402

Opsiyonel flanş ölçüleri için sayfa 587'ye bakınız.
Please see on page 587 for optional flange dimensions
Siehe Seite 587 für auswählbare Flanschabmessungen

* "k1" Ölçüsü frenli redüktörlere aittir.
Dimension "k1" is for motors with brake.
Maße "k1" ist für Bremsenmotoren.

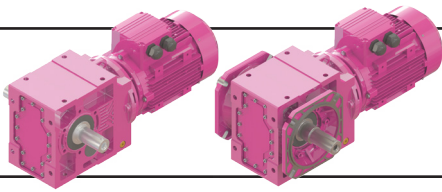

Ölçü Sayfaları Dimension Pages Abmessungsseiten

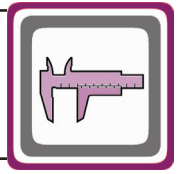

-Mil ucu çektirme deliği DIN 332 sayfa 2 / Tapped center hole to DIN 332, sheet 2 / Zentrierung mit Gewinde DIN 332, Blatt 2

KR873.04

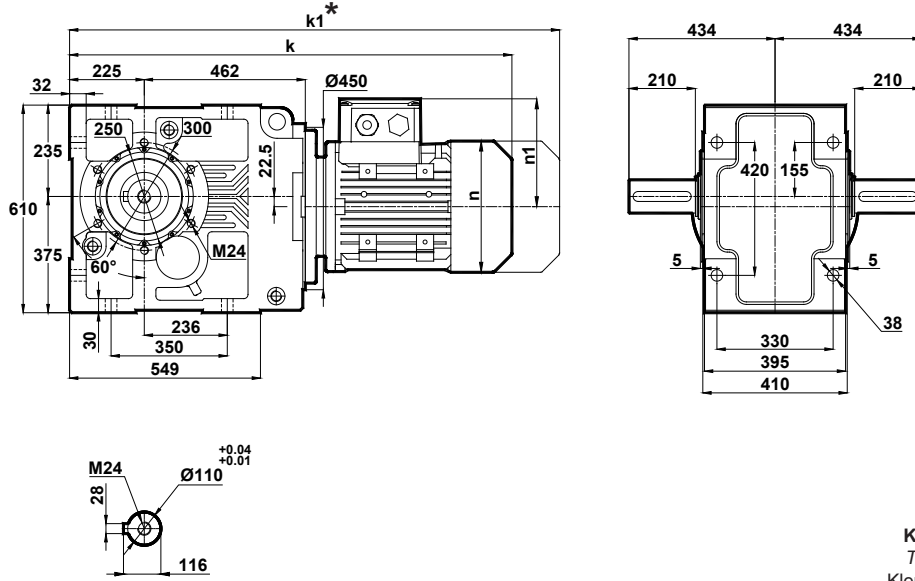

	160M	160L	180M	180L	200L	225S	225M	250M	280S	280M
k	1187.5	1187.5	1259.5	1259.5	1305.5	1335	1360	1450.5	1512.5	1512.5
k1	1335.5	1335.5	1418	1418	1492	1500	1525	1621	1685.5	1691.5
n	316	316	348	348	396	438	438	481	547	547
n1	224	224	250	250	287	316	316	335	402	402

Klemens Pozisyonları
Terminal Box Positions
Klemmenkasten Positionen

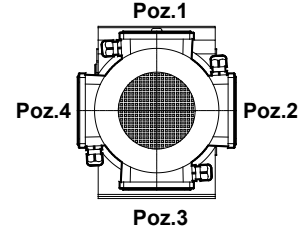

132-160-180-200-225-250-280
Tip / Type / Typ

KR873.05

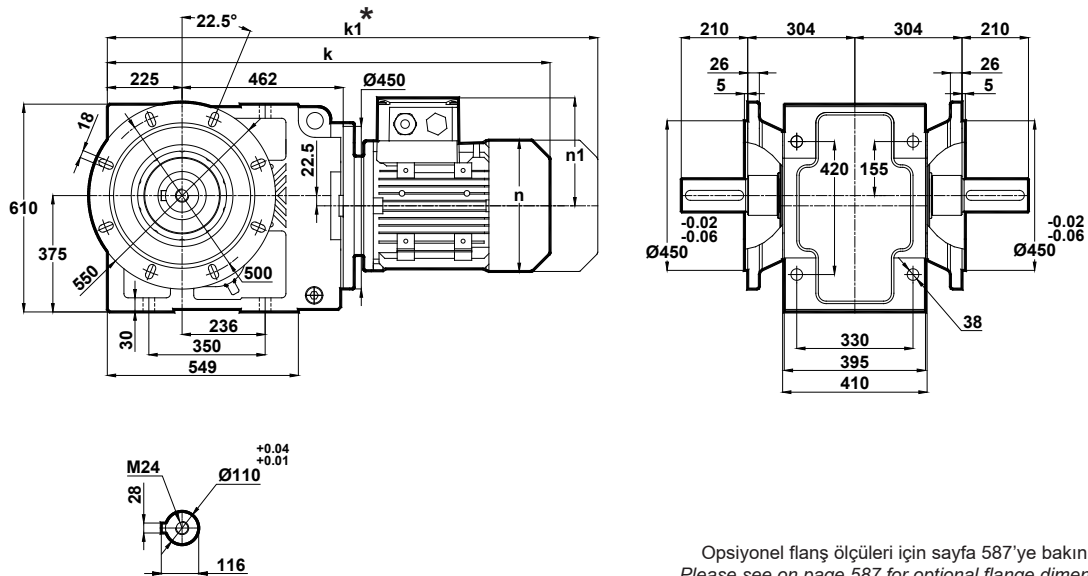

Opsiyonel flanş ölçüleri için sayfa 587'ye bakınız.
Please see on page 587 for optional flange dimensions
Siehe Seite 587 für auswählbare Flanschabmessungen

	160M	160L	180M	180L	200L	225S	225M	250M	280S	280M
k	1187.5	1187.5	1259.5	1259.5	1305.5	1335	1360	1450.5	1512.5	1512.5
k1	1335.5	1335.5	1418	1418	1492	1500	1525	1621	1685.5	1691.5
n	316	316	348	348	396	438	438	481	547	547
n1	224	224	250	250	287	316	316	335	402	402

* "k1" Ölçüsü frenli redüktörlere aittir.
Dimension "k1" is for motors with brake.
Maße "k1" ist für Bremsenmotoren.

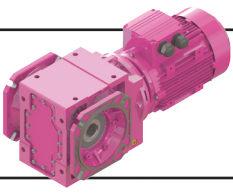

Ölçü Sayfaları Dimension Pages Abmessungsseiten

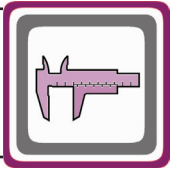

-Mil ucu çektirme deliği DIN 332 sayfa 2 / Tapped center hole to DIN 332, sheet 2 / Zentrierung mit Gewinde DIN 332, Blatt 2

KR873.08

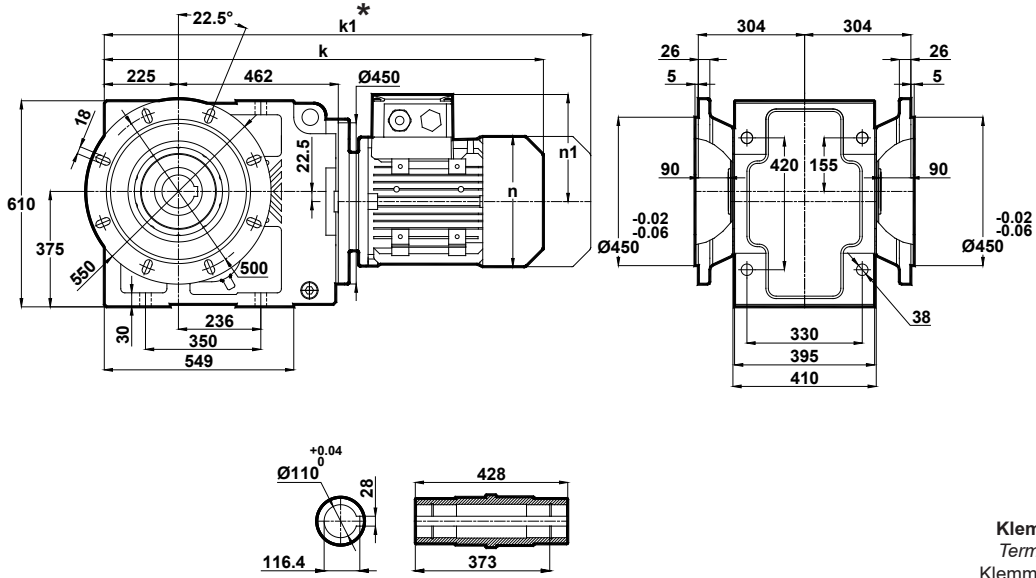

Klemens Pozisyonları
Terminal Box Positions
Klemmenkasten Positionen

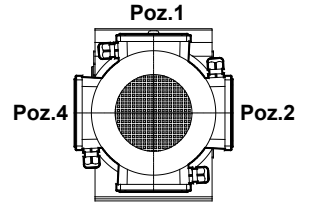

Poz.1
Poz.2
Poz.3
Poz.4
132-160-180-200-225-250-280
Tip / Type / Typ

	160M	160L	180M	180L	200L	225S	225M	250M	280S	280M
k	1187.5	1187.5	1259.5	1259.5	1305.5	1335	1360	1450.5	1512.5	1512.5
k1	1335.5	1335.5	1418	1418	1492	1500	1525	1621	1685.5	1691.5
n	316	316	348	348	396	438	438	481	547	547
n1	224	224	250	250	287	316	316	335	402	402

Opsiyonel flanş ölçüleri için sayfa 587'ye bakınız.
Please see on page 587 for optional flange dimensions
Siehe Seite 587 für auswählbare Flanschabmessungen

* "k1" Ölçüsü frenli redüktörlere aittir.
Dimension "k1" is for motors with brake.
Maße "k1" ist für Bremsenmotoren.

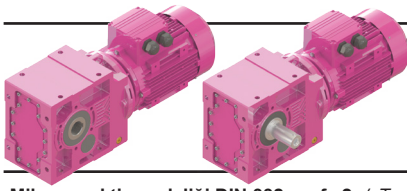

Ölçü Sayfaları

Dimension Pages

Abmessungsseiten

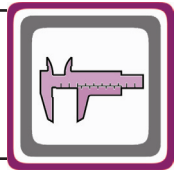

-Mil ucu çektirme deliği DIN 332 sayfa 2 / Tapped center hole to DIN 332, sheet 2 / Zentrierung mit Gewinde DIN 332, Blatt 2

KR874.00

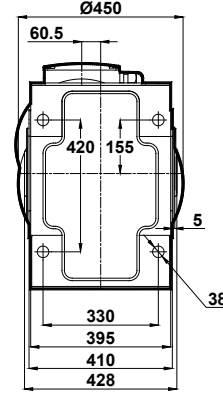
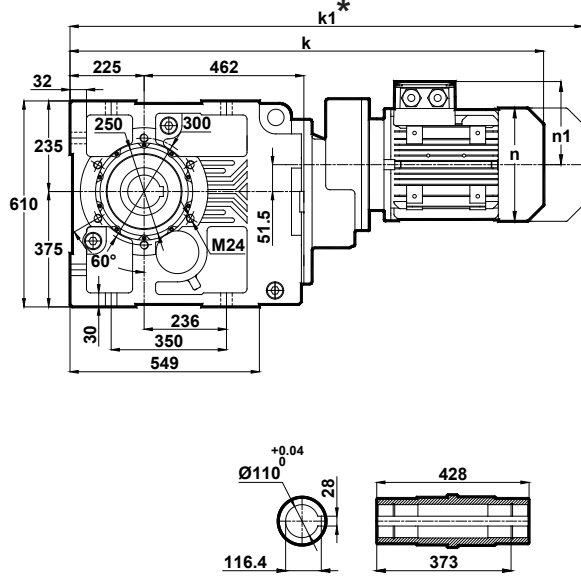

Klemens Pozisyonları
Terminal Box Positions
Klemmenkasten Positionen

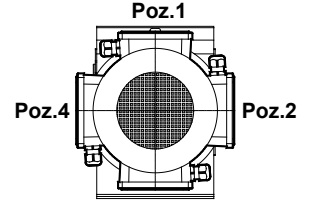

Poz.3
100-112-132-160-180
Tip / Type / Typ

	100L	112M	132S	132M	160M	160L	180M
k	1123	1147	1233.5	1233.5	1329.5	1329.5	1401.5
k1	1231.5	1251.5	1363.5	1363.5	1477.5	1477.5	1560
n	193	215	257	257	316	316	348
n1	149	161	181	181	224	224	250

KR874.01

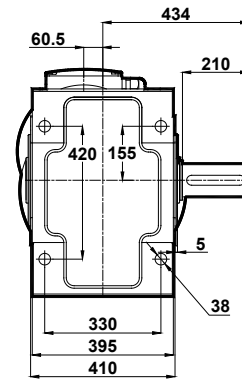
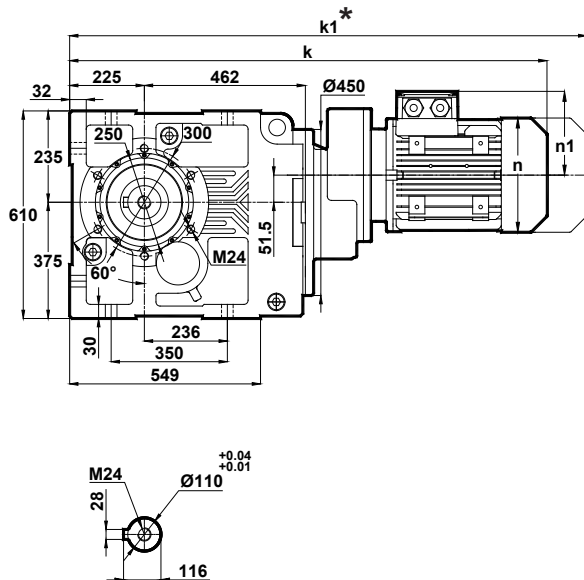

	100L	112M	132S	132M	160M	160L	180M
k	1123	1147	1233.5	1233.5	1329.5	1329.5	1401.5
k1	1231.5	1251.5	1363.5	1363.5	1477.5	1477.5	1560
n	193	215	257	257	316	316	348
n1	149	161	181	181	224	224	250

* "k1" Ölçüsü frenli redüktörlere aittir.
Dimension "k1" is for motors with brake.
Maße "k1" ist für Bremsenmotoren.

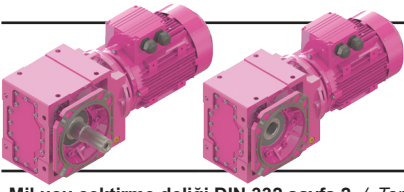

Ölçü Sayfaları Dimension Pages Abmessungsseiten

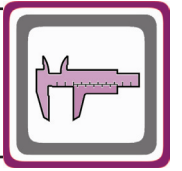

-Mil ucu çektirme deliği DIN 332 sayfa 2 / Tapped center hole to DIN 332, sheet 2 / Zentrierung mit Gewinde DIN 332, Blatt 2

KR874.02

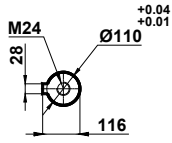
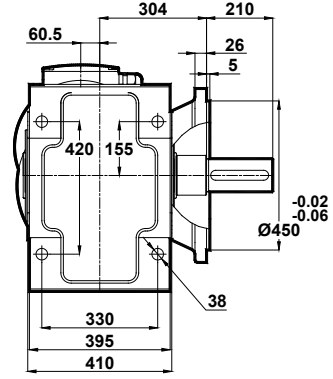
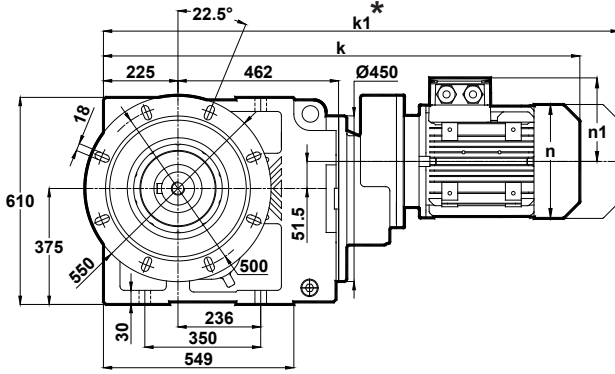

Klemens Pozisyonları
Terminal Box Positions
Klemmenkasten Positionen

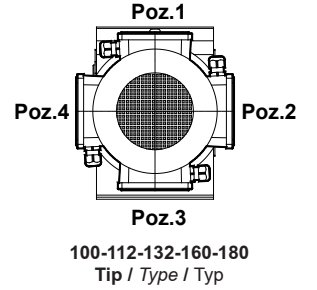

	100L	112M	132S	132M	160M	160L	180M
k	1123	1147	1233.5	1233.5	1329.5	1329.5	1401.5
k1	1231.5	1251.5	1363.5	1363.5	1477.5	1477.5	1560
n	193	215	257	257	316	316	348
n1	149	161	181	181	224	224	250

Opsiyonel flanş ölçüleri için sayfa 587'ye bakınız.
Please see on page 587 for optional flange dimensions
Siehe Seite 587 für auswählbare Flanschabmessungen

KR874.03

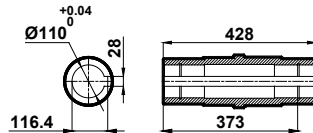
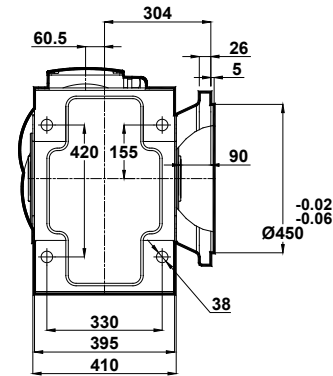
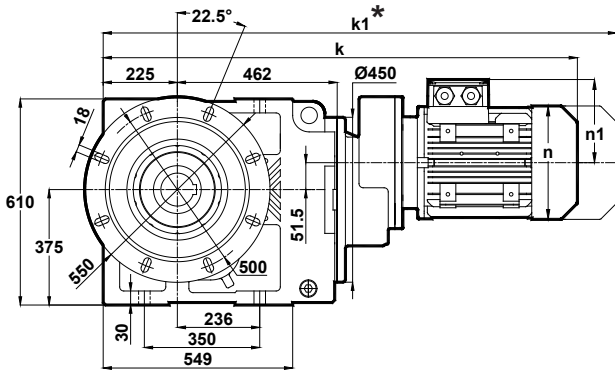

	100L	112M	132S	132M	160M	160L	180M
k	1123	1147	1233.5	1233.5	1329.5	1329.5	1401.5
k1	1231.5	1251.5	1363.5	1363.5	1477.5	1477.5	1560
n	193	215	257	257	316	316	348
n1	149	161	181	181	224	224	250

Opsiyonel flanş ölçüleri için sayfa 587'ye bakınız.
Please see on page 587 for optional flange dimensions
Siehe Seite 587 für auswählbare Flanschabmessungen

* "k1" Ölçüsü frenli redüktörlere aittir.
Dimension "k1" is for motors with brake.
Maße "k1" ist für Bremsenmotoren.

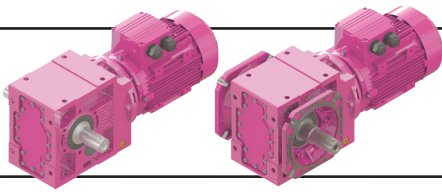

Ölçü Sayfaları

Dimension Pages

Abmessungsseiten

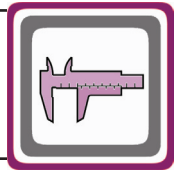

-Mil ucu çektirme deliği DIN 332 sayfa 2 / Tapped center hole to DIN 332, sheet 2 / Zentrierung mit Gewinde DIN 332, Blatt 2

KR874.04

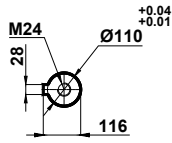
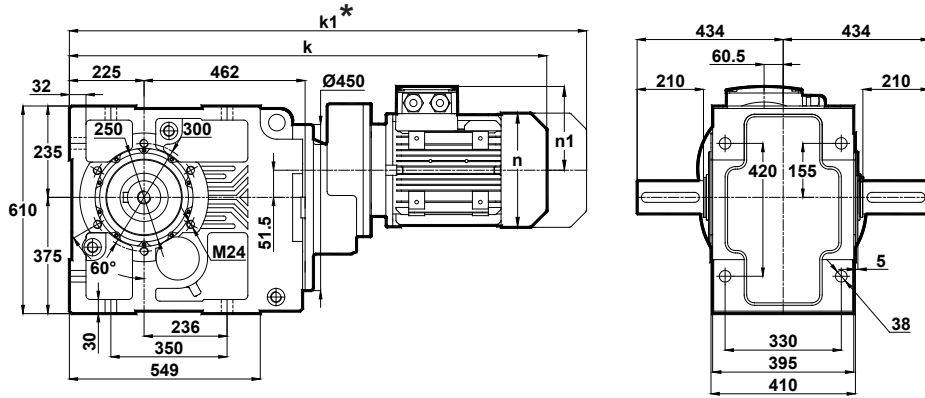

Klemens Pozisyonları
Terminal Box Positions
Klemmenkasten Positionen

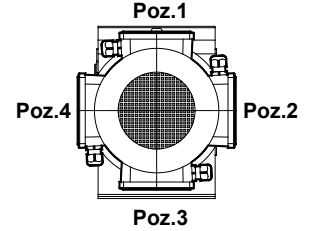

100-112-132-160-180
Tip / Type / Typ

	100L	112M	132S	132M	160M	160L	180M
k	1123	1147	1233.5	1233.5	1329.5	1329.5	1401.5
k1	1231.5	1251.5	1363.5	1363.5	1477.5	1477.5	1560
n	193	215	257	257	316	316	348
n1	149	161	181	181	224	224	250

KR874.05

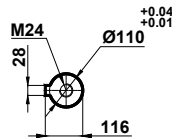
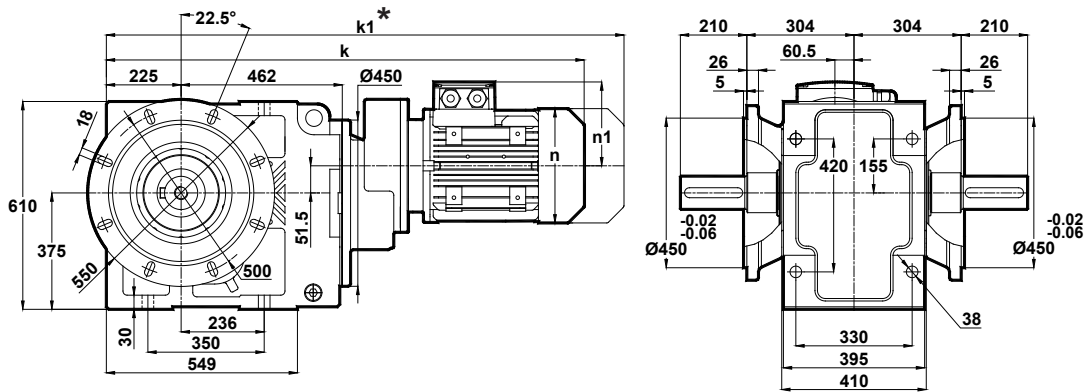

Opsiyonel flanş ölçüleri için sayfa 587'ye bakınız.
Please see on page 587 for optional flange dimensions
Siehe Seite 587 für auswählbare Flanschabmessungen

	100L	112M	132S	132M	160M	160L	180M
k	1123	1147	1233.5	1233.5	1329.5	1329.5	1401.5
k1	1231.5	1251.5	1363.5	1363.5	1477.5	1477.5	1560
n	193	215	257	257	316	316	348
n1	149	161	181	181	224	224	250

* "k1" Ölçüsü frenli redüktörlere aittir.
Dimension "k1" is for motors with brake.
Maße "k1" ist für Bremsenmotoren.

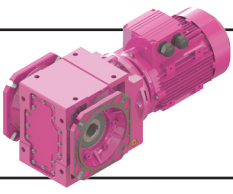

Ölçü Sayfaları Dimension Pages Abmessungenseiten

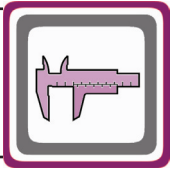

-Mil ucu çektirme deliği DIN 332 sayfa 2 / Tapped center hole to DIN 332, sheet 2 / Zentrierung mit Gewinde DIN 332, Blatt 2

KR874.08

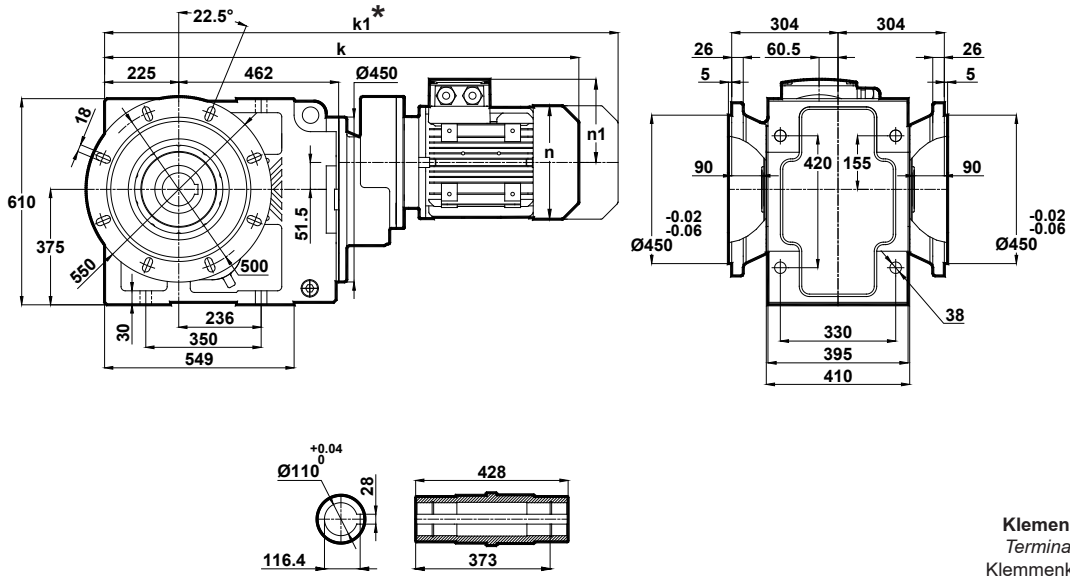

	100L	112M	132S	132M	160M	160L	180M
k	1123	1147	1233.5	1233.5	1329.5	1329.5	1401.5
k1	1231.5	1251.5	1363.5	1363.5	1477.5	1477.5	1560
n	193	215	257	257	316	316	348
n1	149	161	181	181	224	224	250

Klemens Pozisyonları
Terminal Box Positions
Klemmenkasten Positionen

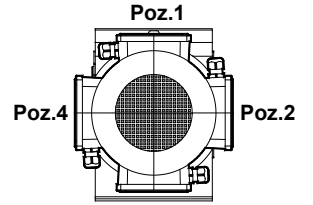

Poz.3

100-112-132-160-180
Tip / Type / Typ

Opsiyonel flanş ölçüleri için sayfa 587'ye bakınız.
Please see on page 587 for optional flange dimensions
Siehe Seite 587 für auswählbare Flanschabmessungen

* "k1" Ölçüsü frenli redüktörlere aittir.
Dimension "k1" is for motors with brake.
Maße "k1" ist für Bremsenmotoren.

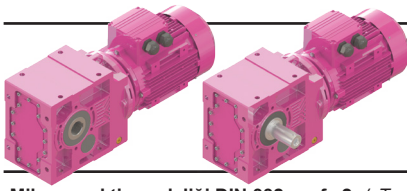

Ölçü Sayfaları Dimension Pages Abmessungsseiten

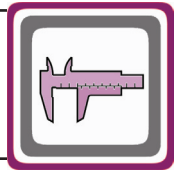

-Mil ucu çektirme deliği DIN 332 sayfa 2 / Tapped center hole to DIN 332, sheet 2 / Zentrierung mit Gewinde DIN 332, Blatt 2

KR875.00
KR876.00

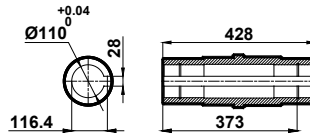
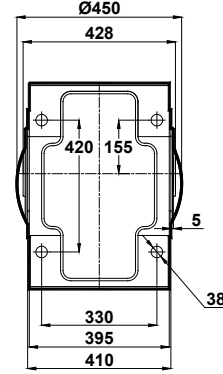
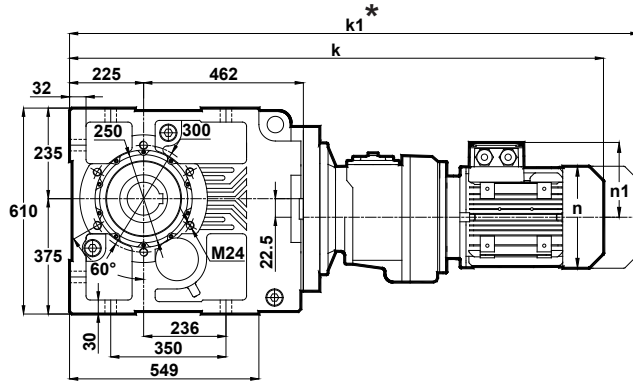

Klemens Pozisyonları
Terminal Box Positions
Klemmenkasten Positionen

	71	80	90S	90L	100L	112M
k	1141.5	1175.5	1214.5	1214.5	1262.5	1286.5
k1	1232.5	1268.5	1318	1318	1371	1391
n	137	155	176	176	193	215
n1	112	123	132	132	149	161

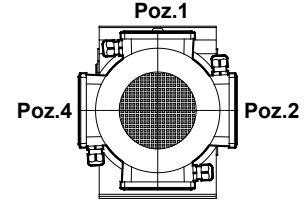

Poz.3
71-80-90-100-112-132
Tip / Type / Typ

KR875.01
KR876.01

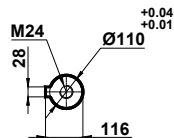
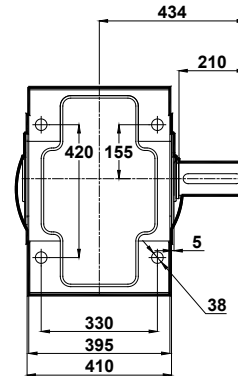
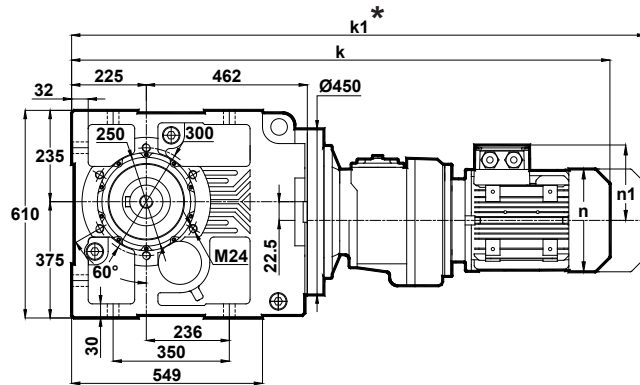

	71	80	90S	90L	100L	112M
k	1141.5	1175.5	1214.5	1214.5	1262.5	1286.5
k1	1232.5	1268.5	1318	1318	1371	1391
n	137	155	176	176	193	215
n1	112	123	132	132	149	161

* "k1" Ölçüsü frenli redüktörlere aittir.
Dimension "k1" is for motors with brake.
Maße "k1" ist für Bremsenmotoren.

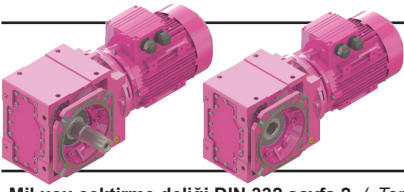

Ölçü Sayfaları Dimension Pages Abmessungsseiten

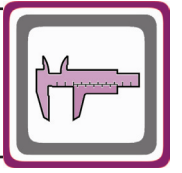

-Mil ucu çektirme deliği DIN 332 sayfa 2 / Tapped center hole to DIN 332, sheet 2 / Zentrierung mit Gewinde DIN 332, Blatt 2

KR875.02
KR876.02

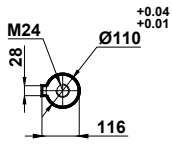
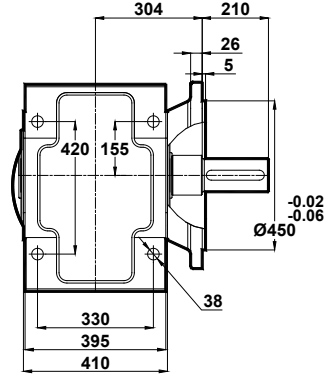
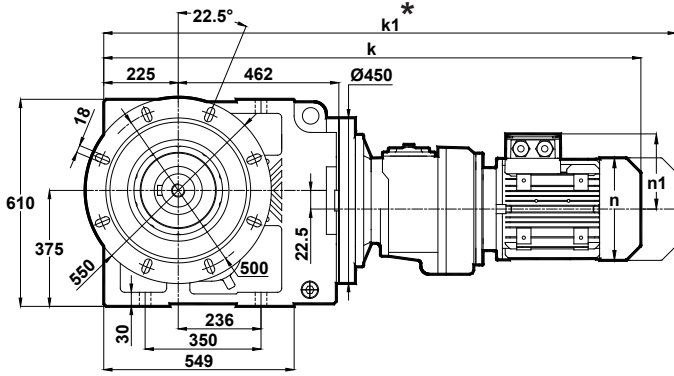

Klemens Pozisyonları
Terminal Box Positions
Klemmenkasten Positionen

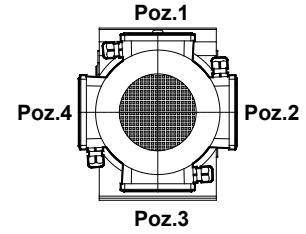

71-80-90-100-112-132
Tip / Type / Typ

Opsiyonel flanş ölçüleri için sayfa 587'ye bakınız.
Please see on page 587 for optional flange dimensions
Siehe Seite 587 für auswählbare Flanschabmessungen

	71	80	90S	90L	100L	112M
k	1141.5	1175.5	1214.5	1214.5	1262.5	1286.5
k1	1232.5	1268.5	1318	1318	1371	1391
n	137	155	176	176	193	215
n1	112	123	132	132	149	161

KR875.03
KR876.03

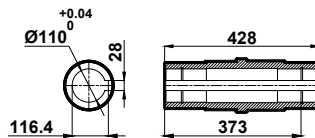
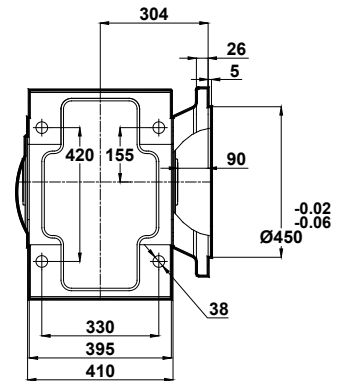
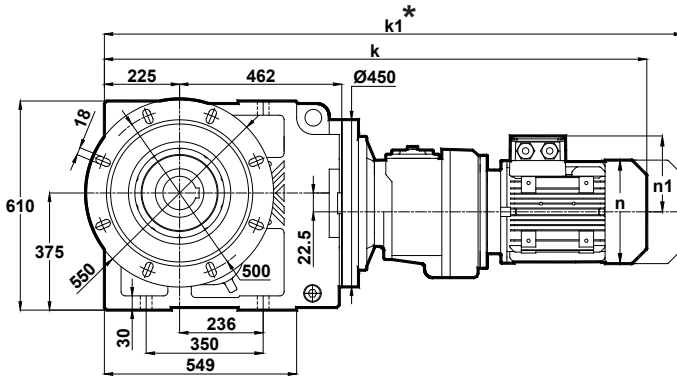

	71	80	90S	90L	100L	112M
k	1141.5	1175.5	1214.5	1214.5	1262.5	1286.5
k1	1232.5	1268.5	1318	1318	1371	1391
n	137	155	176	176	193	215
n1	112	123	132	132	149	161

Opsiyonel flanş ölçüleri için sayfa 587'ye bakınız.
Please see on page 587 for optional flange dimensions
Siehe Seite 587 für auswählbare Flanschabmessungen

* "k1" Ölçüsü frenli redüktörlere aittir.
Dimension "k1" is for motors with brake.
Maße "k1" ist für Bremsenmotoren.

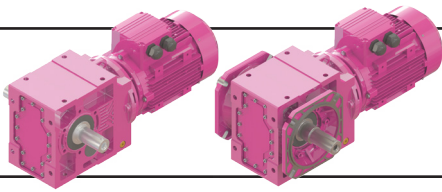

Ölçü Sayfaları Dimension Pages Abmessungsseiten

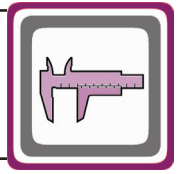

-Mil ucu çektirme deliği DIN 332 sayfa 2 / Tapped center hole to DIN 332, sheet 2 / Zentrierung mit Gewinde DIN 332, Blatt 2

KR875.04
KR876.04

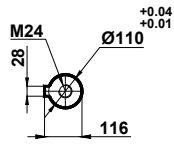
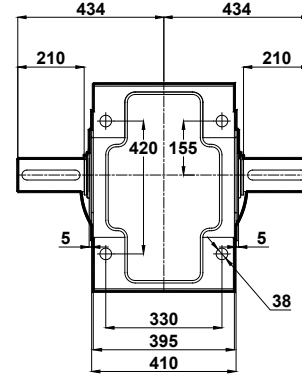
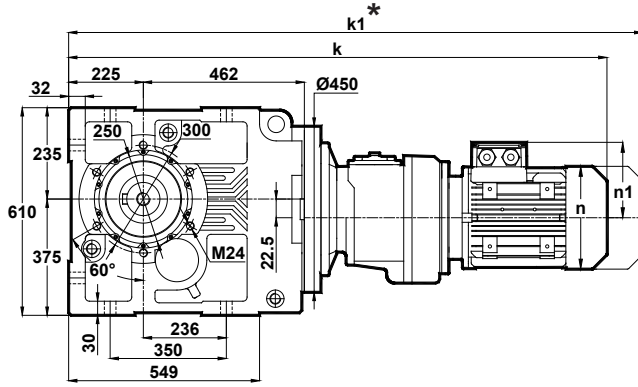

Klemens Pozisyonları
Terminal Box Positions
Klemmenkasten Positionen

	71	80	90S	90L	100L	112M
k	1141.5	1175.5	1214.5	1214.5	1262.5	1286.5
k1	1232.5	1268.5	1318	1318	1371	1391
n	137	155	176	176	193	215
n1	112	123	132	132	149	161

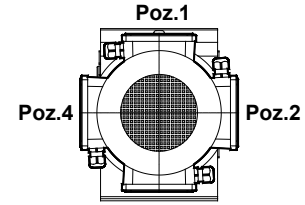

Poz.3
71-80-90-100-112-132
Tip / Type / Typ

KR875.05
KR876.05

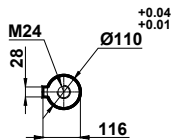
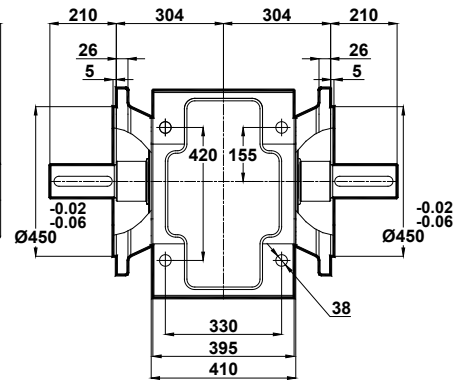
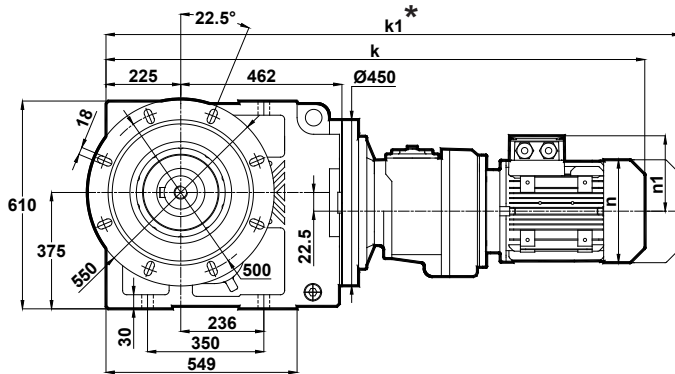

Opsiyonel flanş ölçüleri için sayfa 587'ye bakınız.
Please see on page 587 for optional flange dimensions
Siehe Seite 587 für auswählbare Flanschabmessungen

	71	80	90S	90L	100L	112M
k	1141.5	1175.5	1214.5	1214.5	1262.5	1286.5
k1	1232.5	1268.5	1318	1318	1371	1391
n	137	155	176	176	193	215
n1	112	123	132	132	149	161

* "k1" Ölçüsü frenli redüktörlere aittir.
Dimension "k1" is for motors with brake.
Maße "k1" ist für Bremsenmotoren.

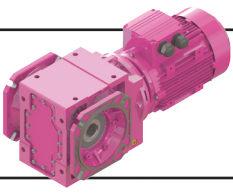

Ölçü Sayfaları

Dimension Pages

Abmessungsseiten

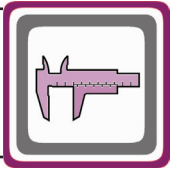

-Mil ucu çektirme deliği DIN 332 sayfa 2 / Tapped center hole to DIN 332, sheet 2 / Zentrierung mit Gewinde DIN 332, Blatt 2

KR875.08
KR876.08

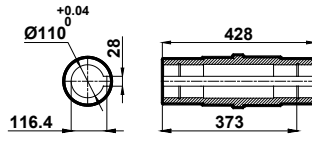
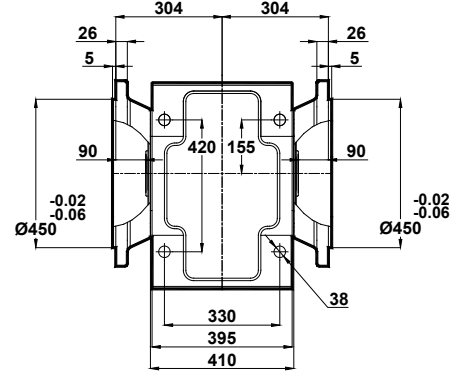
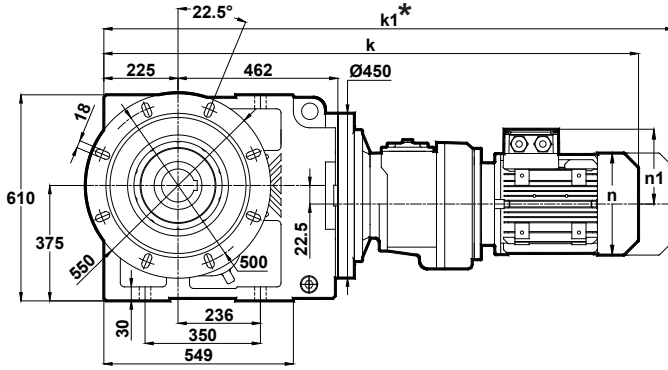

Klemens Pozisyonları
Terminal Box Positions
Klemmenkasten Positionen

	71	80	90S	90L	100L	112M
k	1141.5	1175.5	1214.5	1214.5	1262.5	1286.5
k1	1232.5	1268.5	1318	1318	1371	1391
n	137	155	176	176	193	215
n1	112	123	132	132	149	161

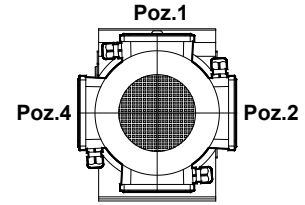

Poz.3
71-80-90-100-112-132
Tip / Type / Typ

Opsiyonel flanş ölçüleri için sayfa 587'ye bakınız.
Please see on page 587 for optional flange dimensions
Siehe Seite 587 für auswählbare Flanschabmessungen

* "k1" Ölçüsü frenli redüktörlere aittir.
Dimension "k1" is for motors with brake.
Maße "k1" ist für Bremsenmotoren.

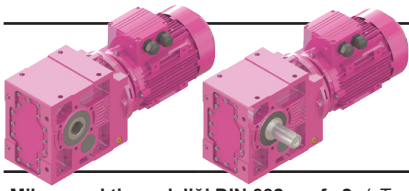

Ölçü Sayfaları

Dimension Pages

Abmessungsseiten

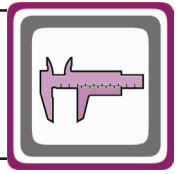

-Mil ucu çektirme deliği DIN 332 sayfa 2 / Tapped center hole to DIN 332, sheet 2 / Zentrierung mit Gewinde DIN 332, Blatt 2

KR973.00

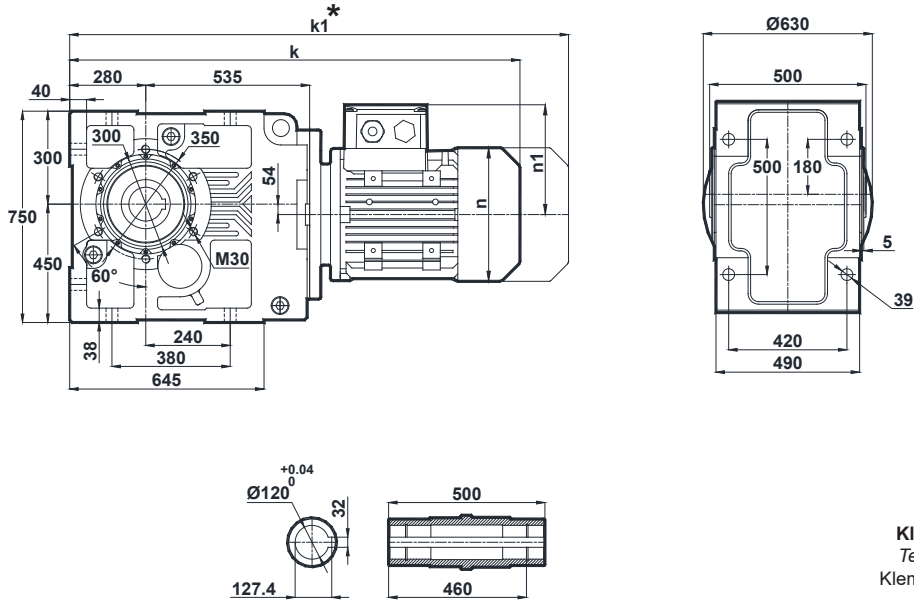

Klemens Pozisyonları
Terminal Box Positions
Klemmenkasten Positionen

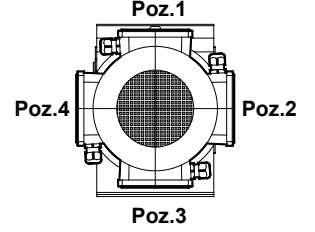

160-180-200-225-250-280-315
Tip / Type / Typ

	160M	160L	180M	180L	200L	225S	225M	250M	280S	280M	315S	315M
k	1307.5	1307.5	1379.5	1379.5	1432	1490	1490	1571.5	1665	1665	1773.5	1773.5
k1	1455.5	1455.5	1538	1538	1614	1672.5	1672.5	1729	1863	1863	-	-
n	316	316	348	348	396	438	438	481	547	547	614	614
n1	224	224	250	250	287	316	316	335	402	402	510	510

KR973.01

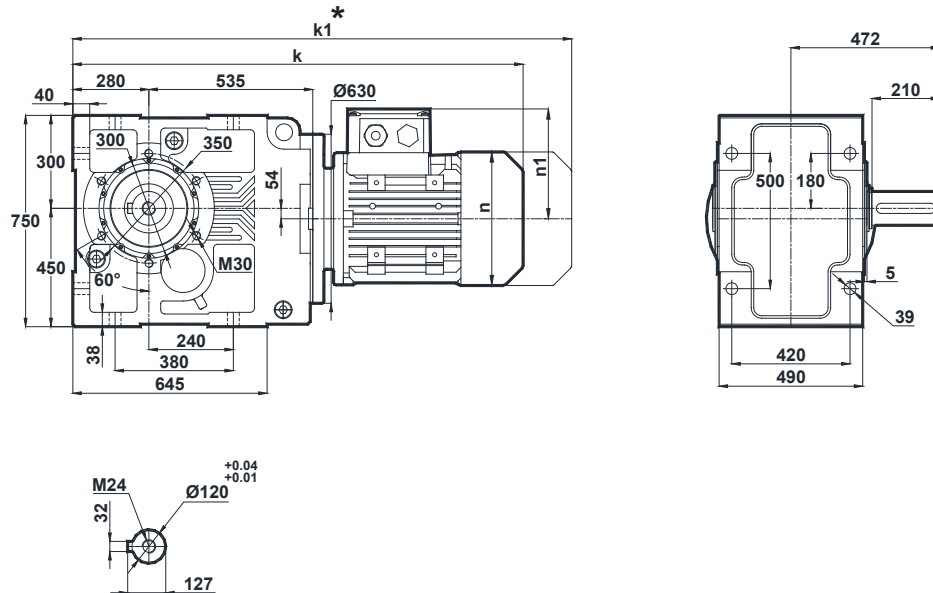

* "k1" Ölçüsü frenli redüktörlere aittir.
Dimension "k1" is for motors with brake.
Maße "k1" ist für Bremsenmotoren.

	160M	160L	180M	180L	200L	225S	225M	250M	280S	280M	315S	315M
k	1307.5	1307.5	1379.5	1379.5	1432	1490	1490	1571.5	1665	1665	1773.5	1773.5
k1	1455.5	1455.5	1538	1538	1614	1672.5	1672.5	1729	1863	1863	-	-
n	316	316	348	348	396	438	438	481	547	547	614	614
n1	224	224	250	250	287	316	316	335	402	402	510	510

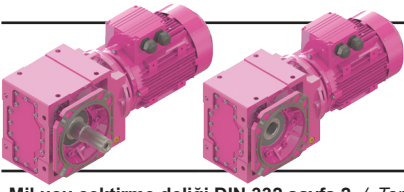

Ölçü Sayfaları Dimension Pages Abmessungenseiten

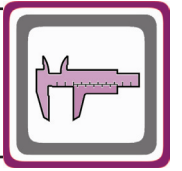

-Mil ucu çektirme deliği DIN 332 sayfa 2 / Tapped center hole to DIN 332, sheet 2 / Zentrierung mit Gewinde DIN 332, Blatt 2

KR973.02

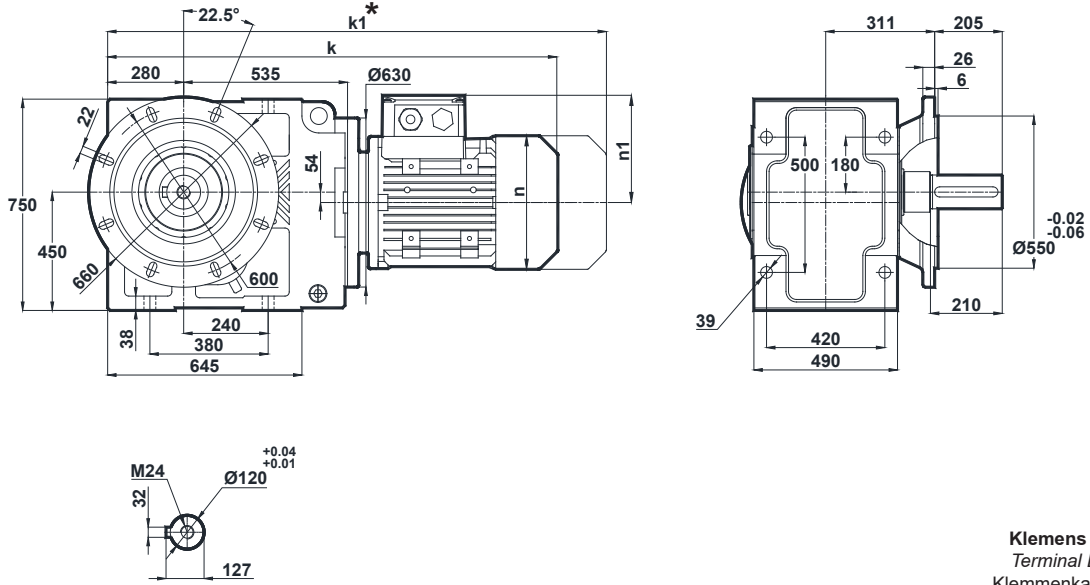

Klemens Pozisyonları
Terminal Box Positions
Klemmenkasten Positionen

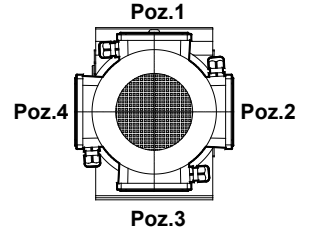

160-180-200-225-250-280-315
Tip / Type / Typ

	160M	160L	180M	180L	200L	225S	225M	250M	280S	280M	315S	315M
k	1307.5	1307.5	1379.5	1379.5	1432	1490	1490	1571.5	1665	1665	1773.5	1773.5
k1	1455.5	1455.5	1538	1538	1614	1672.5	1672.5	1729	1863	1863	-	-
n	316	316	348	348	396	438	438	481	547	547	614	614
n1	224	224	250	250	287	316	316	335	402	402	510	510

KR973.03

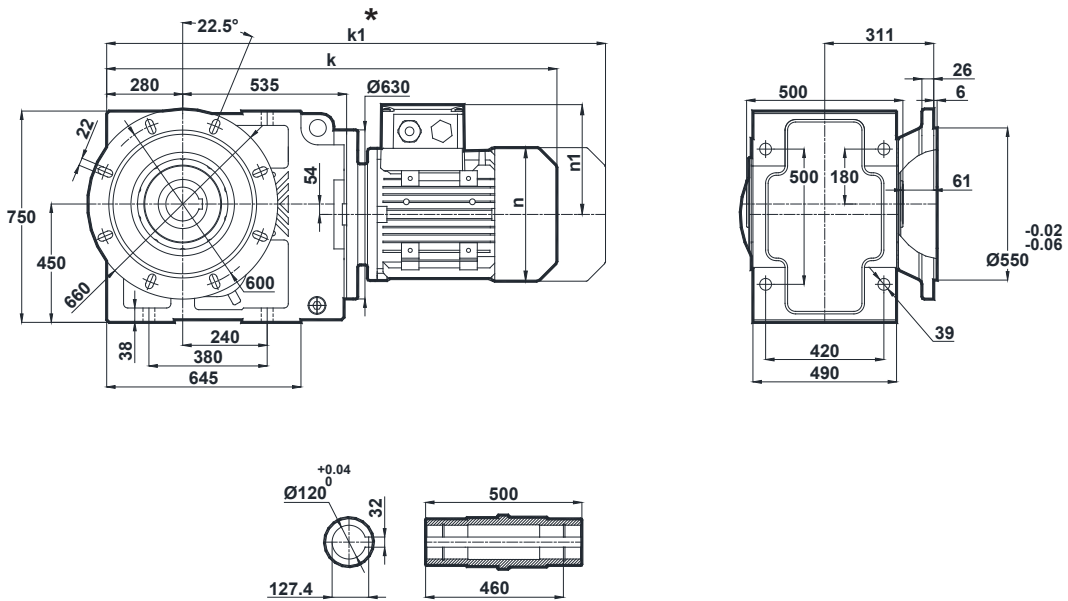

	160M	160L	180M	180L	200L	225S	225M	250M	280S	280M	315S	315M
k	1307.5	1307.5	1379.5	1379.5	1432	1490	1490	1571.5	1665	1665	1773.5	1773.5
k1	1455.5	1455.5	1538	1538	1614	1672.5	1672.5	1729	1863	1863	-	-
n	316	316	348	348	396	438	438	481	547	547	614	614
n1	224	224	250	250	287	316	316	335	402	402	510	510

* "k1" Ölçüsü frenli redüktörlere aittir.
Dimension "k1" is for motors with brake.
Maße "k1" ist für Bremsenmotoren.

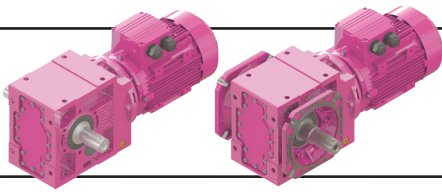

Ölçü Sayfaları

Dimension Pages

Abmessungsseiten

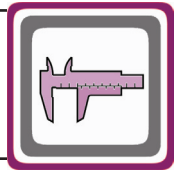

-Mil ucu çektirme deliği DIN 332 sayfa 2 / Tapped center hole to DIN 332, sheet 2 / Zentrierung mit Gewinde DIN 332, Blatt 2

KR973.04

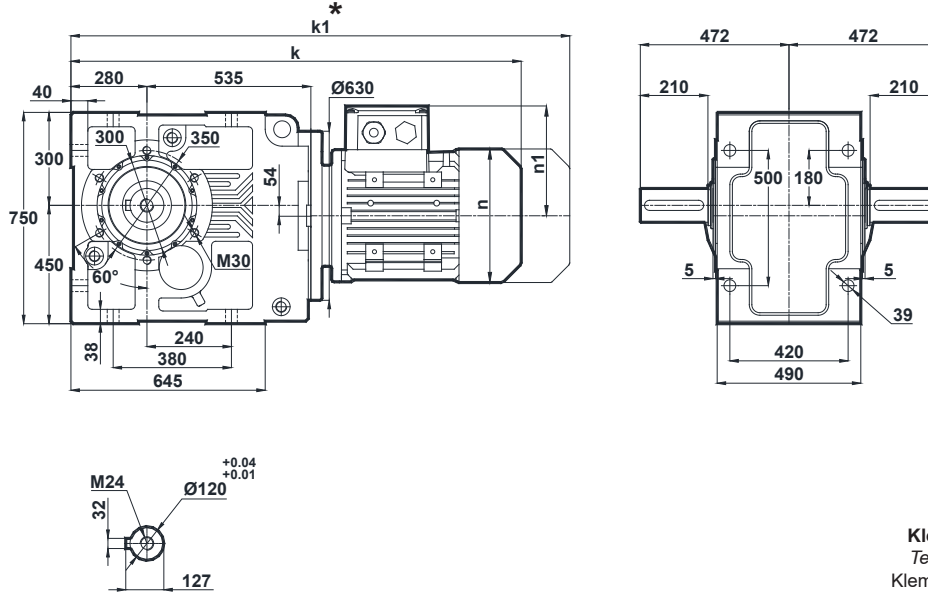

Klemens Pozisyonları
Terminal Box Positions
Klemmenkasten Positionen

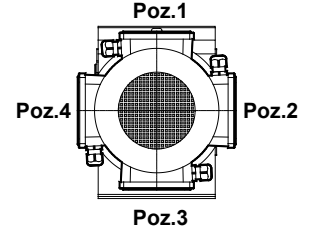

160-180-200-225-250-280-315
Tip / Type / Typ

	160M	160L	180M	180L	200L	225S	225M	250M	280S	280M	315S	315M
k	1307.5	1307.5	1379.5	1379.5	1432	1490	1490	1571.5	1665	1665	1773.5	1773.5
k1	1455.5	1455.5	1538	1538	1614	1672.5	1672.5	1729	1863	1863	-	-
n	316	316	348	348	396	438	438	481	547	547	614	614
n1	224	224	250	250	287	316	316	335	402	402	510	510

KR973.05

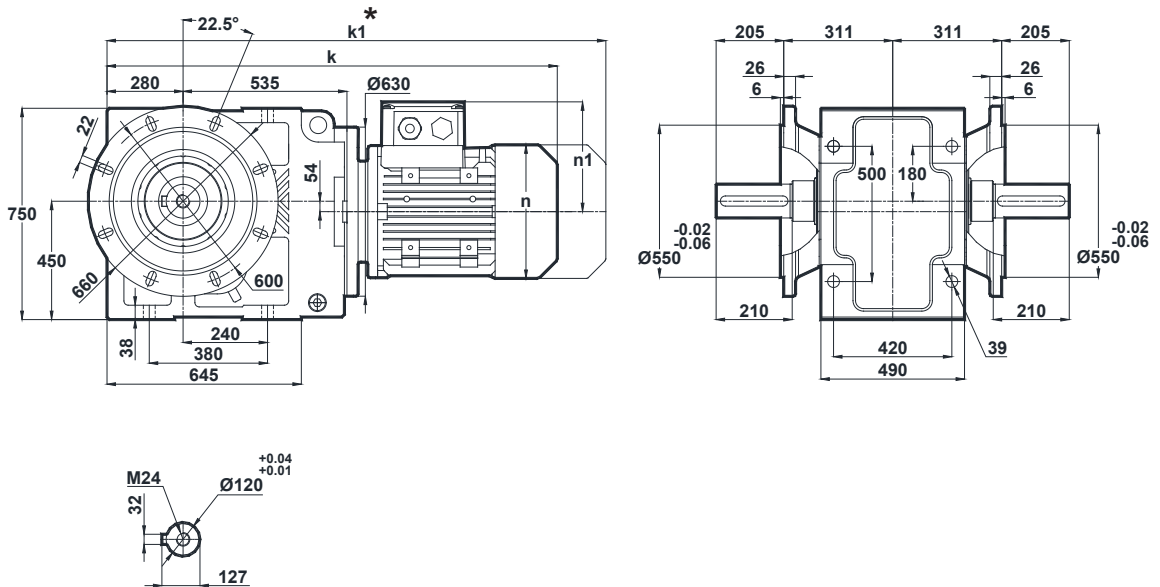

* "k1" Ölçüsü frenli redüktörlere aittir.
Dimension "k1" is for motors with brake.
Maße "k1" ist für Bremsenmotoren.

	160M	160L	180M	180L	200L	225S	225M	250M	280S	280M	315S	315M
k	1307.5	1307.5	1379.5	1379.5	1432	1490	1490	1571.5	1665	1665	1773.5	1773.5
k1	1455.5	1455.5	1538	1538	1614	1672.5	1672.5	1729	1863	1863	-	-
n	316	316	348	348	396	438	438	481	547	547	614	614
n1	224	224	250	250	287	316	316	335	402	402	510	510

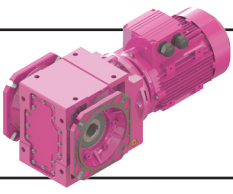

Ölçü Sayfaları Dimension Pages Abmessungsseiten

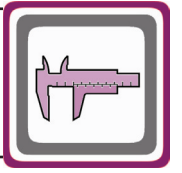

-Mil ucu çektirme deliği DIN 332 sayfa 2 / Tapped center hole to DIN 332, sheet 2 / Zentrierung mit Gewinde DIN 332, Blatt 2

KR973.08

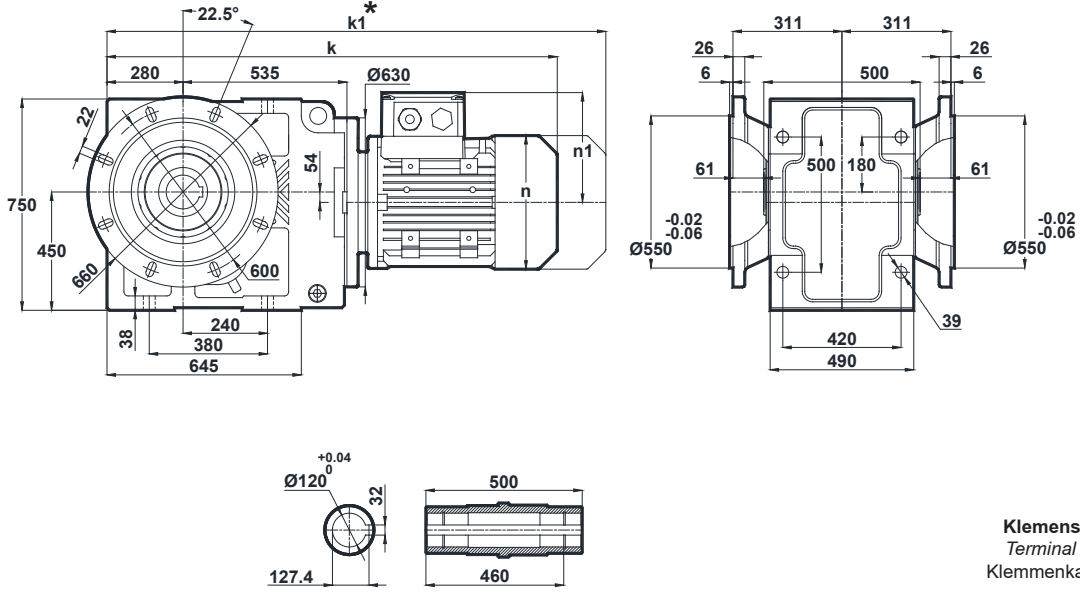

Klemens Pozisyonları
Terminal Box Positions
Klemmenkasten Positionen

	160M	160L	180M	180L	200L	225S	225M	250M	280S	280M	315S	315M
k	1307.5	1307.5	1379.5	1379.5	1432	1490	1490	1571.5	1665	1665	1773.5	1773.5
k1	1455.5	1455.5	1538	1538	1614	1672.5	1672.5	1729	1863	1863	-	-
n	316	316	348	348	396	438	438	481	547	547	614	614
n1	224	224	250	250	287	316	316	335	402	402	510	510

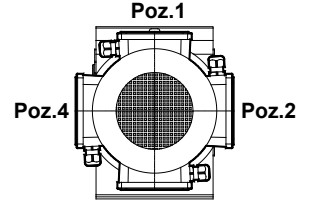

Poz.1
Poz.2
Poz.3
Poz.4
160-180-200-225-250-280-315
Tip / Type / Typ

* "k1" Ölçüsü frenli redüktörlere aittir.
Dimension "k1" is for motors with brake.
Maße "k1" ist für Bremsenmotoren.

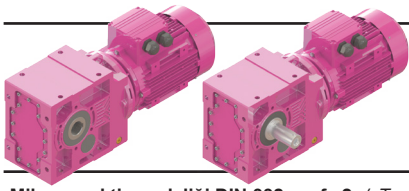

Ölçü Sayfaları

Dimension Pages

Abmessungsseiten

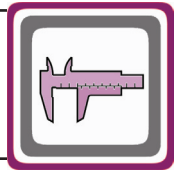

-Mil ucu çektirme deliği DIN 332 sayfa 2 / Tapped center hole to DIN 332, sheet 2 / Zentrierung mit Gewinde DIN 332, Blatt 2

KR974.00

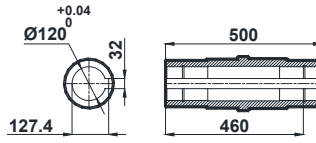
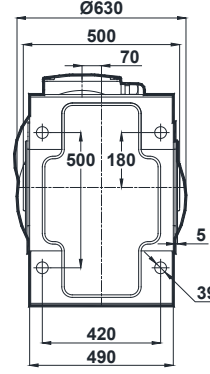
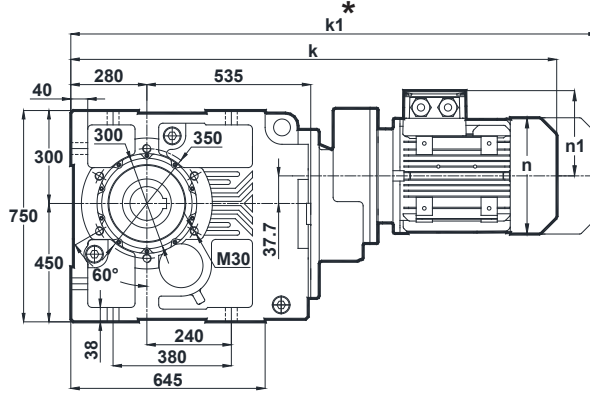

	100L	112M	132S	132M	160M	160L	180M	180L
k	1277	1301	1387.5	1387.5	1483.5	1483.5	1555.5	1555.5
k1	1385.5	1405.5	1517.5	1517.5	1631.5	1631.5	1714	1714
n	193	215	257	257	316	316	348	348
n1	149	161	181	181	224	224	250	250

Klemens Pozisyonları
Terminal Box Positions
Klemmenkasten Positionen

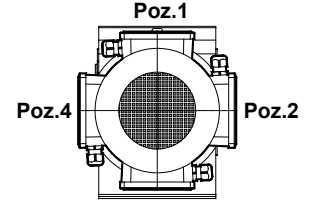

Poz.3
100-112-132-160-180
Tip / Type / Typ

KR974.01

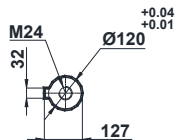
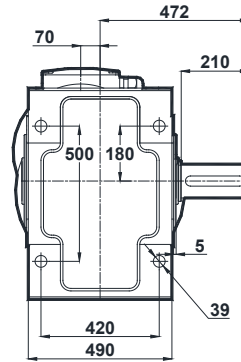
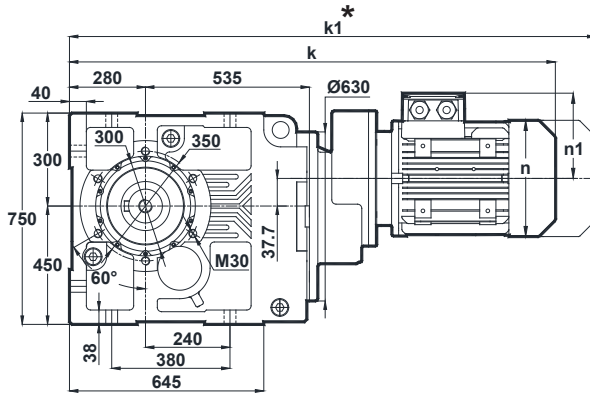

	100L	112M	132S	132M	160M	160L	180M	180L
k	1277	1301	1387.5	1387.5	1483.5	1483.5	1555.5	1555.5
k1	1385.5	1405.5	1517.5	1517.5	1631.5	1631.5	1714	1714
n	193	215	257	257	316	316	348	348
n1	149	161	181	181	224	224	250	250

* "k1" Ölçüsü frenli redüktörlere aittir.
Dimension "k1" is for motors with brake.
Maße "k1" ist für Bremsenmotoren.

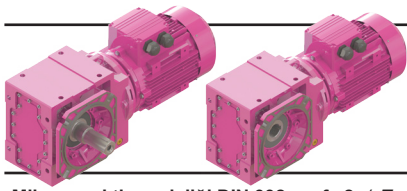

Ölçü Sayfaları Dimension Pages Abmessungsseiten

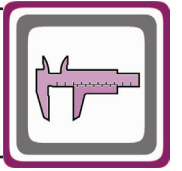

-Mil ucu çektirme deliği DIN 332 sayfa 2 / Tapped center hole to DIN 332, sheet 2 / Zentrierung mit Gewinde DIN 332, Blatt 2

KR974.02

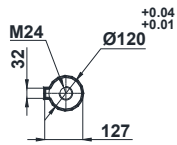
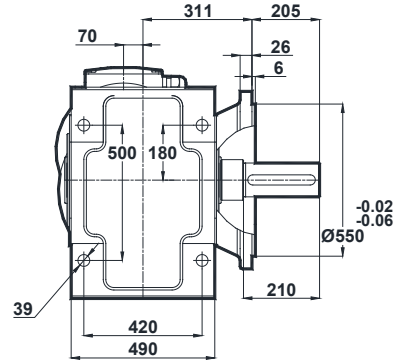
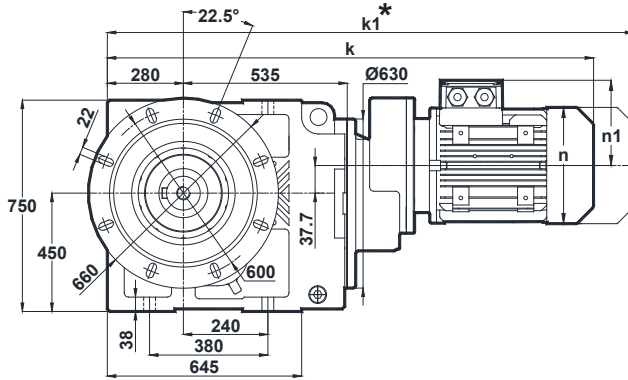

	100L	112M	132S	132M	160M	160L	180M	180L
k	1277	1301	1387.5	1387.5	1483.5	1483.5	1555.5	1555.5
k1	1385.5	1405.5	1517.5	1517.5	1631.5	1631.5	1714	1714
n	193	215	257	257	316	316	348	348
n1	149	161	181	181	224	224	250	250

Klemens Pozisyonları
Terminal Box Positions
Klemmenkasten Positionen

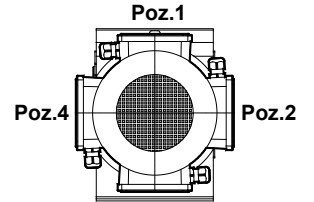

Poz.3

100-112-132-160-180
Tip / Type / Typ

KR974.03

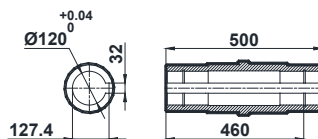
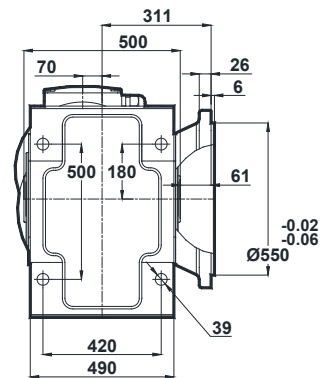
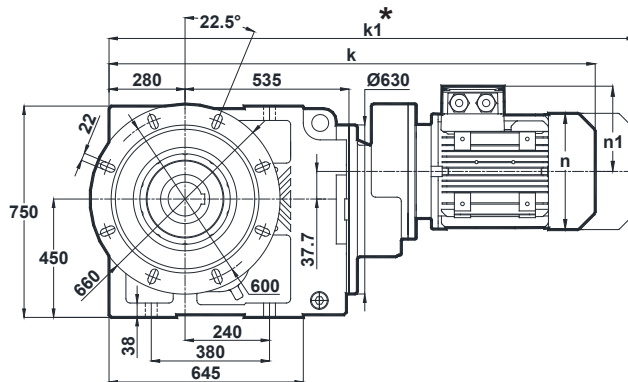

	100L	112M	132S	132M	160M	160L	180M	180L
k	1277	1301	1387.5	1387.5	1483.5	1483.5	1555.5	1555.5
k1	1385.5	1405.5	1517.5	1517.5	1631.5	1631.5	1714	1714
n	193	215	257	257	316	316	348	348
n1	149	161	181	181	224	224	250	250

* "k1" Ölçüsü frenli redüktörlere aittir.
Dimension "k1" is for motors with brake.
Maße "k1" ist für Bremsenmotoren.

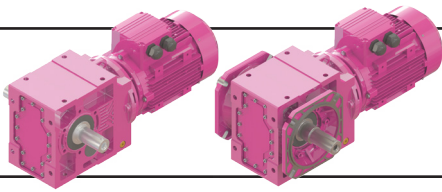

Ölçü Sayfaları Dimension Pages Abmessungsseiten

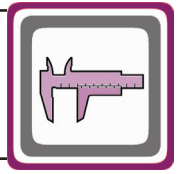

-Mil ucu çektirme deliği DIN 332 sayfa 2 / Tapped center hole to DIN 332, sheet 2 / Zentrierung mit Gewinde DIN 332, Blatt 2

KR974.04

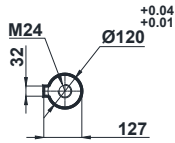
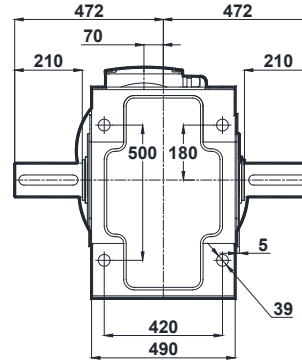
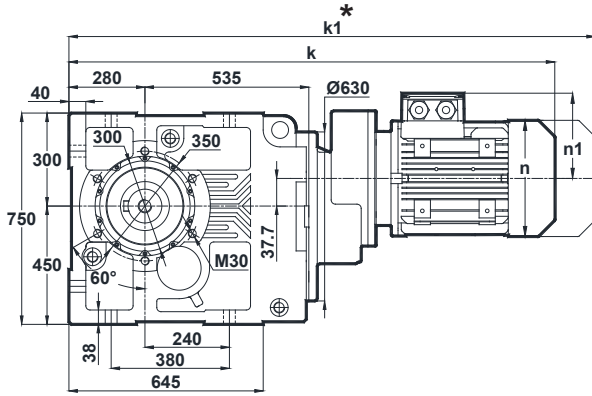

Klemens Pozisyonları
Terminal Box Positions
Klemmenkasten Positionen

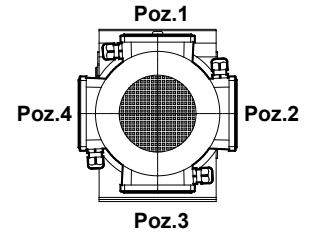

Poz.3
100-112-132-160-180
Tip / Type / Typ

	100L	112M	132S	132M	160M	160L	180M	180L
k	1277	1301	1387.5	1387.5	1483.5	1483.5	1555.5	1555.5
k1	1385.5	1405.5	1517.5	1517.5	1631.5	1631.5	1714	1714
n	193	215	257	257	316	316	348	348
n1	149	161	181	181	224	224	250	250

KR974.05

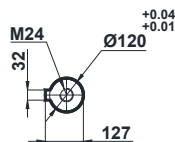
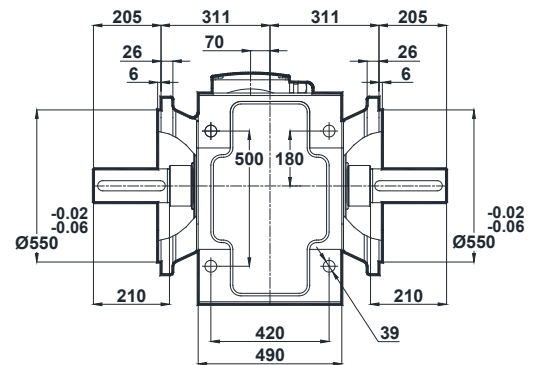
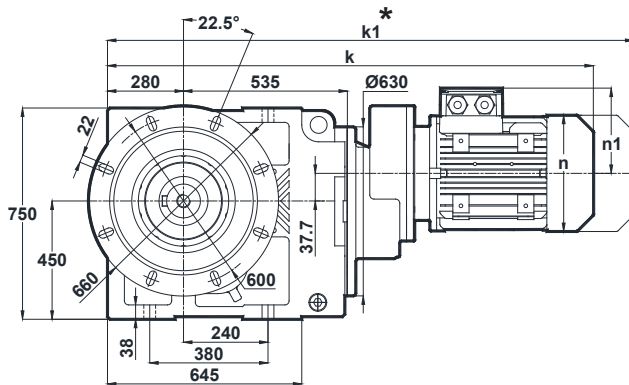

	100L	112M	132S	132M	160M	160L	180M	180L
k	1277	1301	1387.5	1387.5	1483.5	1483.5	1555.5	1555.5
k1	1385.5	1405.5	1517.5	1517.5	1631.5	1631.5	1714	1714
n	193	215	257	257	316	316	348	348
n1	149	161	181	181	224	224	250	250

* "k1" Ölçüsü frenli redüktörlere aittir.
Dimension "k1" is for motors with brake.
Maße "k1" ist für Bremsenmotoren.

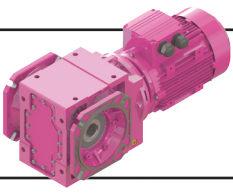

Ölçü Sayfaları

Dimension Pages

Abmessungsseiten

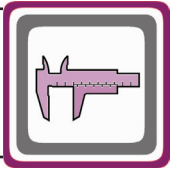

-Mil ucu çektirme deliği DIN 332 sayfa 2 / Tapped center hole to DIN 332, sheet 2 / Zentrierung mit Gewinde DIN 332, Blatt 2

KR974.08

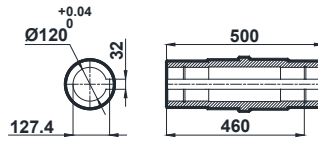
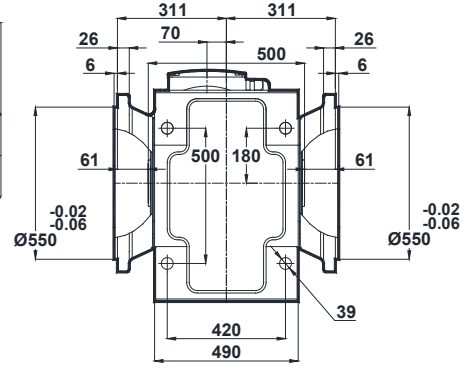
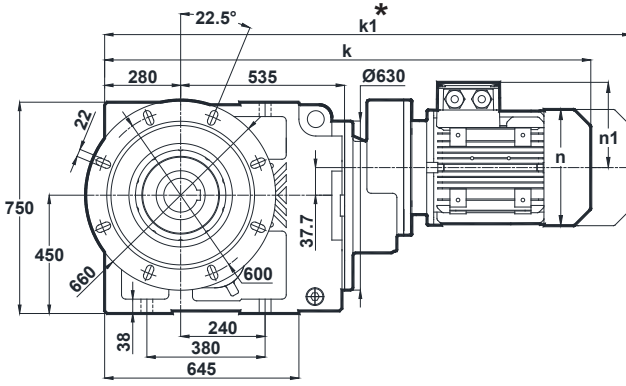

Klemens Pozisyonları
Terminal Box Positions
Klemmenkasten Positionen

	100L	112M	132S	132M	160M	160L	180M	180L
k	1277	1301	1387.5	1387.5	1483.5	1483.5	1555.5	1555.5
k1	1385.5	1405.5	1517.5	1517.5	1631.5	1631.5	1714	1714
n	193	215	257	257	316	316	348	348
n1	149	161	181	181	224	224	250	250

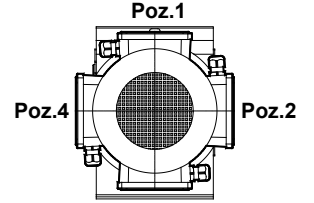

Poz.3

100-112-132-160-180
Tip / Type / Typ

* "k1" Ölçüsü frenli redüktörlere aittir.
Dimension "k1" is for motors with brake.
Maße "k1" ist für Bremsenmotoren.

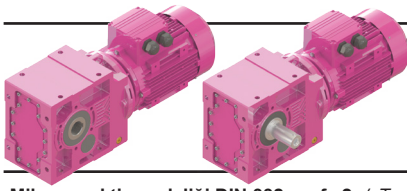

Ölçü Sayfaları Dimension Pages Abmessungsseiten

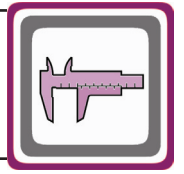

-Mil ucu çektirme deliği DIN 332 sayfa 2 / Tapped center hole to DIN 332, sheet 2 / Zentrierung mit Gewinde DIN 332, Blatt 2

KR975.00
KR976.00

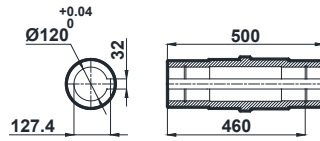
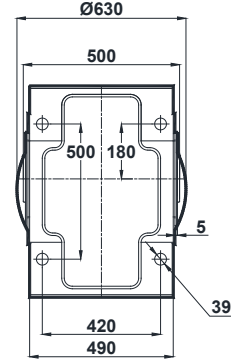
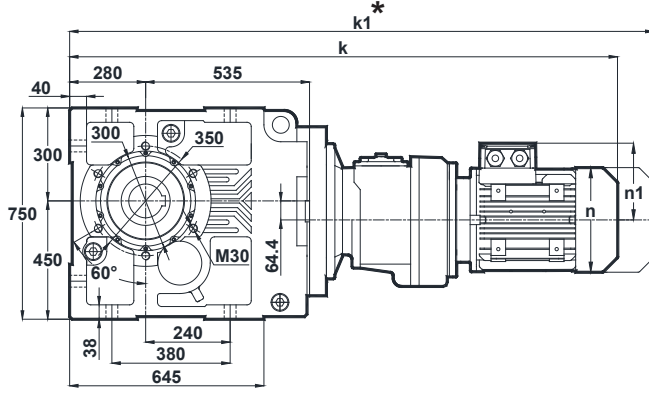

	80	90S	90L	100L	112M	132S	132M
k	1355.5	1394.5	1394.5	1439.5	1463.5	1548.5	1548.5
k1	1448.5	1498	1498	1548	1568	1678.5	1678.5
n	155	176	176	193	215	257	257
n1	123	132	132	149	161	181	181

Klemens Pozisyonları
Terminal Box Positions
Klemmenkasten Positionen

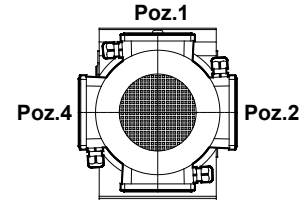

Poz.3
80-90-100-112-132
Tip / Type / Typ

KR975.01
KR976.01

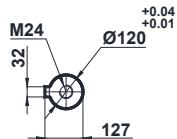
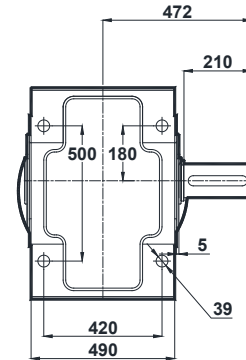
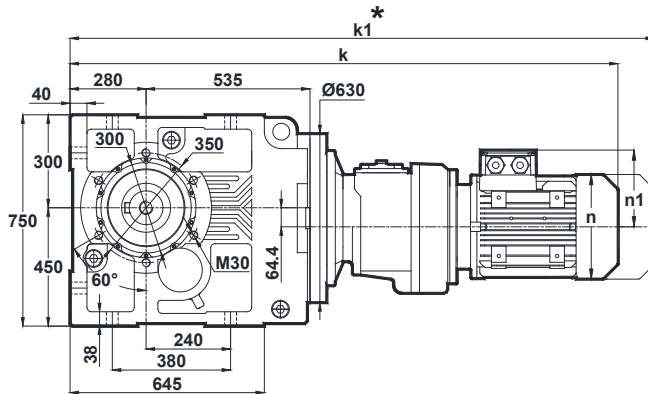

	80	90S	90L	100L	112M	132S	132M
k	1355.5	1394.5	1394.5	1439.5	1463.5	1548.5	1548.5
k1	1448.5	1498	1498	1548	1568	1678.5	1678.5
n	155	176	176	193	215	257	257
n1	123	132	132	149	161	181	181

* "k1" Ölçüsü frenli redüktörlere aittir.
Dimension "k1" is for motors with brake.
Maße "k1" ist für Bremsenmotoren.

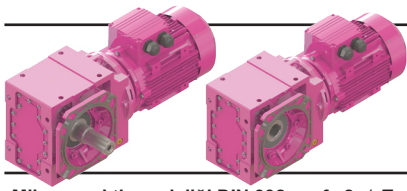

Ölçü Sayfaları

Dimension Pages

Abmessungsseiten

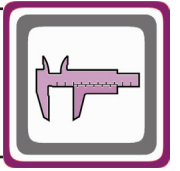

-Mil ucu çektirme deliği DIN 332 sayfa 2 / Tapped center hole to DIN 332, sheet 2 / Zentrierung mit Gewinde DIN 332, Blatt 2

KR975.02
KR976.02

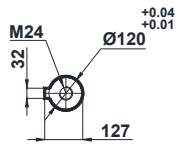
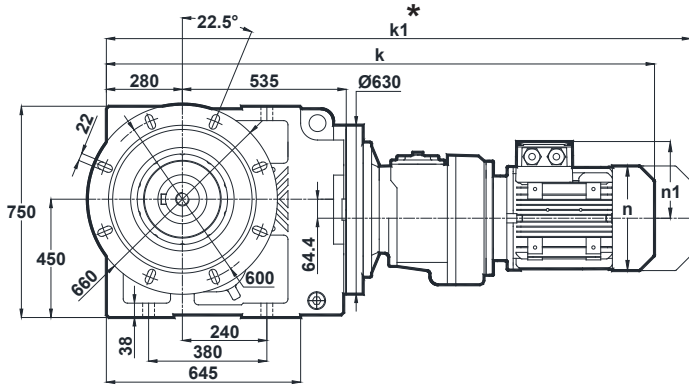

	80	90S	90L	100L	112M	132S	132M
k	1355.5	1394.5	1394.5	1439.5	1463.5	1548.5	1548.5
k1	1448.5	1498	1498	1548	1568	1678.5	1678.5
n	155	176	176	193	215	257	257
n1	123	132	132	149	161	181	181

Klemens Pozisyonları
Terminal Box Positions
Klemmenkasten Positionen

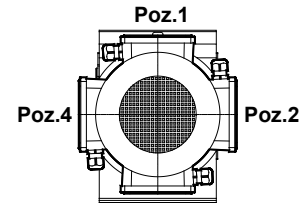

Poz.3
80-90-100-112-132
Tip / Type / Typ

KR975.03
KR976.03

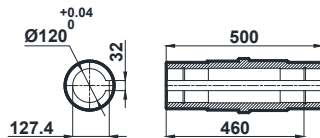
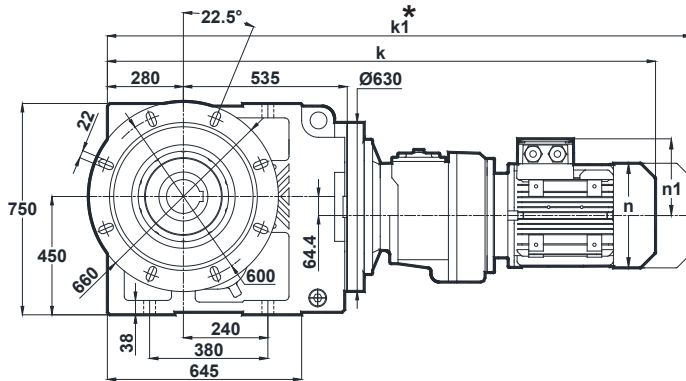

	80	90S	90L	100L	112M	132S	132M
k	1355.5	1394.5	1394.5	1439.5	1463.5	1548.5	1548.5
k1	1448.5	1498	1498	1548	1568	1678.5	1678.5
n	155	176	176	193	215	257	257
n1	123	132	132	149	161	181	181

* "k1" Ölçüsü frenli redüktörlere aittir.
Dimension "k1" is for motors with brake.
Maße "k1" ist für Bremsenmotoren.

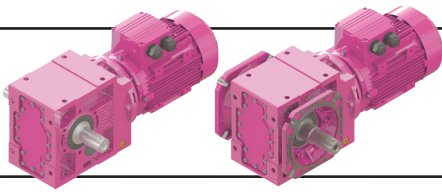

Ölçü Sayfaları Dimension Pages Abmessungsseiten

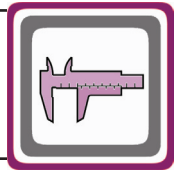

-Mil ucu çektirme deliği DIN 332 sayfa 2 / Tapped center hole to DIN 332, sheet 2 / Zentrierung mit Gewinde DIN 332, Blatt 2

KR975.04
KR976.04

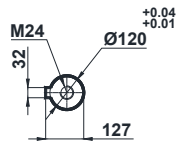
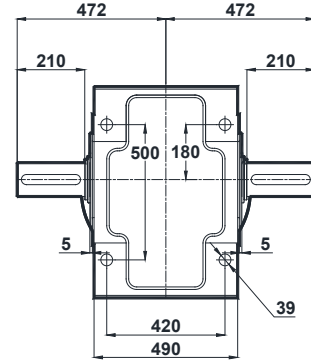
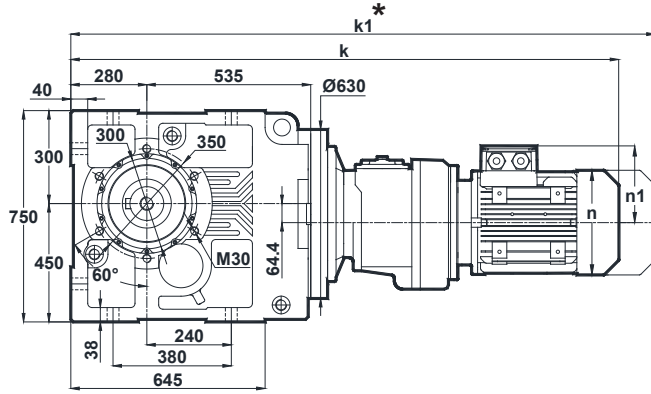

	80	90S	90L	100L	112M	132S	132M
k	1355.5	1394.5	1394.5	1439.5	1463.5	1548.5	1548.5
k1	1448.5	1498	1498	1548	1568	1678.5	1678.5
n	155	176	176	193	215	257	257
n1	123	132	132	149	161	181	181

Klemens Pozisyonları
Terminal Box Positions
Klemmenkasten Positionen

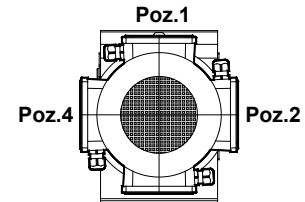

Poz.3
80-90-100-112-132
Tip / Type / Typ

KR975.05
KR976.05

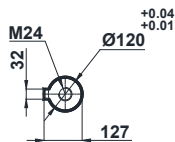
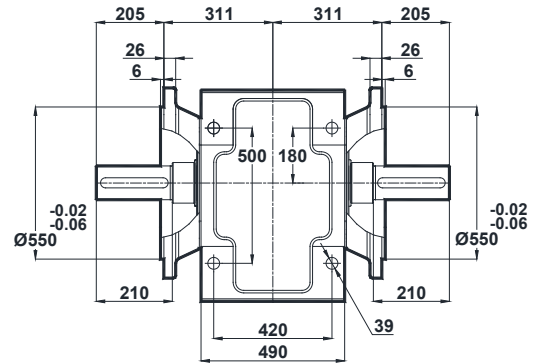
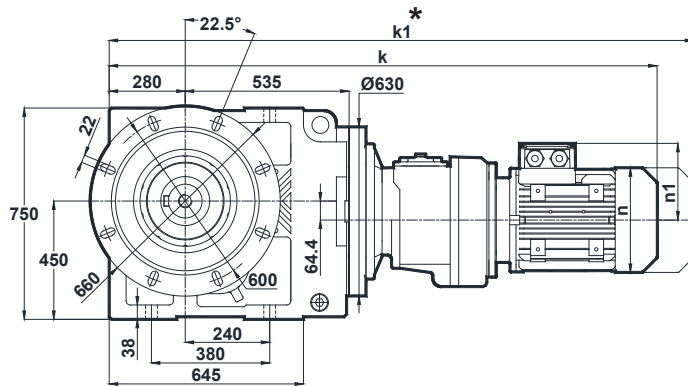

	80	90S	90L	100L	112M	132S	132M
k	1355.5	1394.5	1394.5	1439.5	1463.5	1548.5	1548.5
k1	1448.5	1498	1498	1548	1568	1678.5	1678.5
n	155	176	176	193	215	257	257
n1	123	132	132	149	161	181	181

* "k1" Ölçüsü frenli redüktörlere aittir.
Dimension "k1" is for motors with brake.
Maße "k1" ist für Bremsenmotoren.

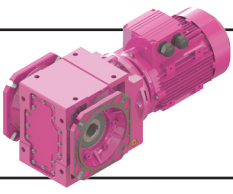

Ölçü Sayfaları Dimension Pages Abmessungsseiten

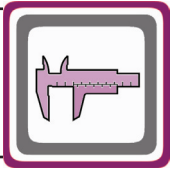

-Mil ucu çektirme deliği DIN 332 sayfa 2 / Tapped center hole to DIN 332, sheet 2 / Zentrierung mit Gewinde DIN 332, Blatt 2

KR975.08
KR976.08

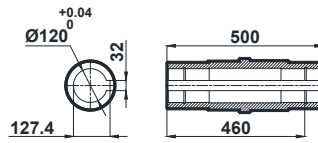
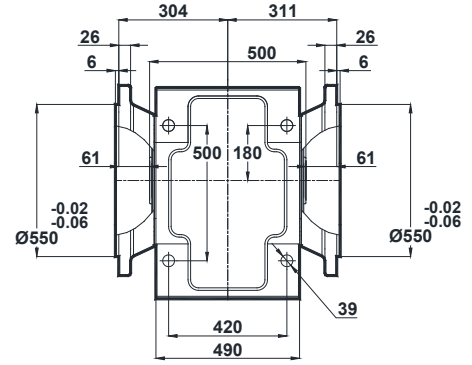
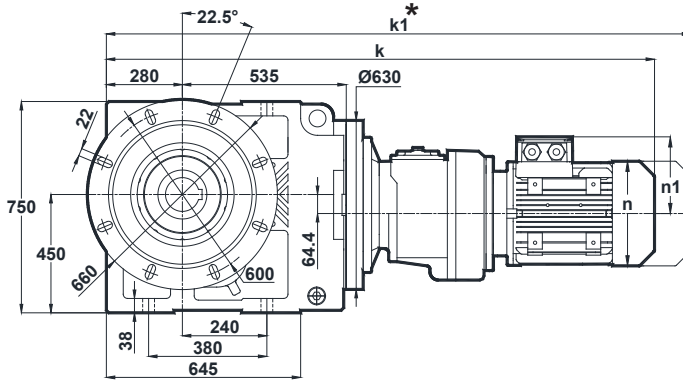

	80	90S	90L	100L	112M	132S	132M
k	1355.5	1394.5	1394.5	1439.5	1463.5	1548.5	1548.5
k1	1448.5	1498	1498	1548	1568	1678.5	1678.5
n	155	176	176	193	215	257	257
n1	123	132	132	149	161	181	181

Klemens Pozisyonları
Terminal Box Positions
Klemmenkasten Positionen

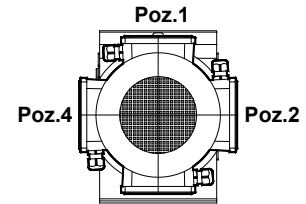

Poz.3
80-90-100-112-132
Tip / Type / Typ

* "k1" Ölçüsü frenli redüktörlere aittir.
Dimension "k1" is for motors with brake.
Maße "k1" ist für Bremsenmotoren.

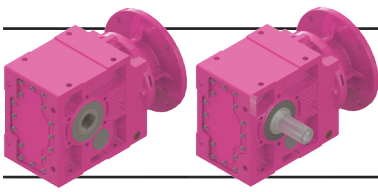

Ölçü Sayfaları

Dimension Pages

Abmessungsseiten

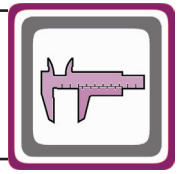

-Mil ucu çektirme deliği DIN 332 sayfa 2 / Tapped center hole to DIN 332, sheet 2 / Zentrierung mit Gewinde DIN 332, Blatt 2

KN002.00
KN003.00

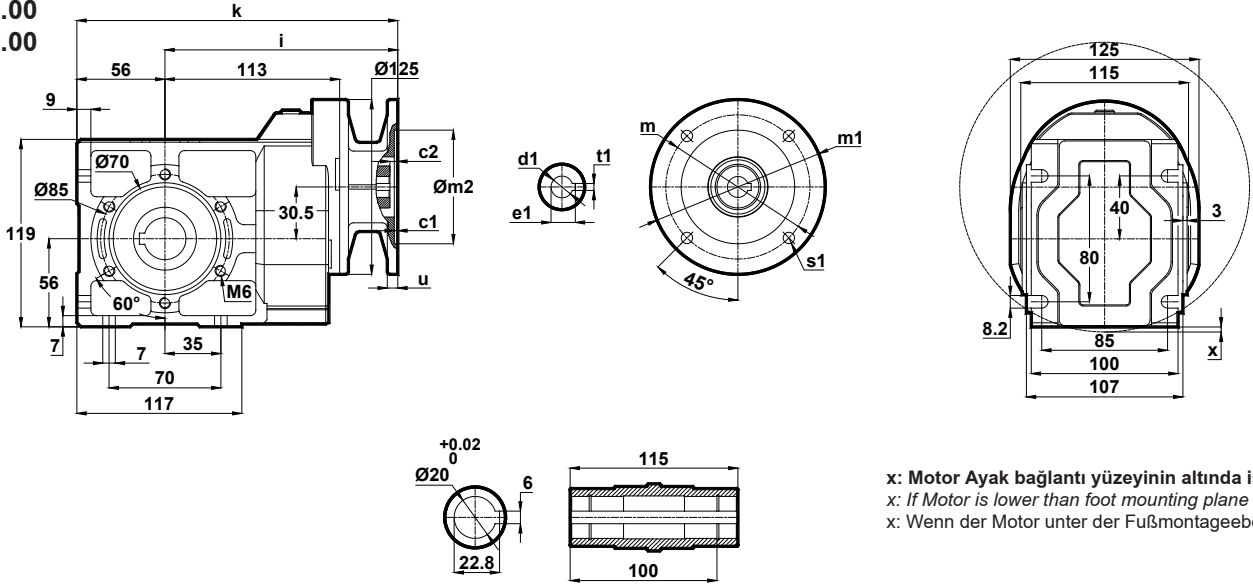

x: Motor Ayak bağlantı yüzeyinin altında ise
x: If Motor is lower than foot mounting plane
x: Wenn der Motor unter der Fußmontageebene ist

	c1	c2	s1	m	m1	m2	i	u	k	d1	t1	e1	x
63/B5	3.5	5	10	115	140	95	156	10	212	11	4	12.8	-
63/B14	2.5	5	5.5	75	90	60	156	10	212	11	4	12.8	-
71/B5	4	4.5	11	130	160	110	157.5	12	213.5	14	5	16.3	-
71/B14	3	4.5	7	85	105	70	157.5	10	213.5	14	5	16.3	-
80/B5	4	5	12	165	200	130	172.5	12	228.5	19	6	21.8	13.5
80/B14	4	5	7	100	120	80	172.5	12	228.5	19	6	21.8	-
90/B5	4	5	12	165	200	130	172.5	12	228.5	24	8	27.3	13.5
90/B14	4	5	9	115	140	95	172.5	12	228.5	24	8	27.3	-

KN002.01
KN003.01

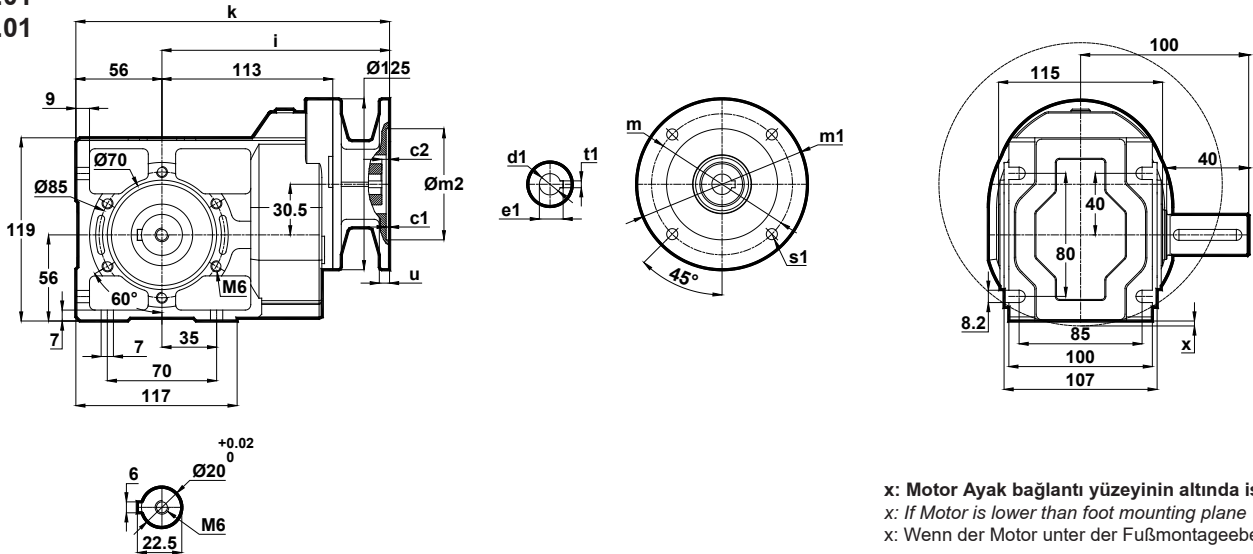

x: Motor Ayak bağlantı yüzeyinin altında ise
x: If Motor is lower than foot mounting plane
x: Wenn der Motor unter der Fußmontageebene ist

	c1	c2	s1	m	m1	m2	i	u	k	d1	t1	e1	x
63/B5	3.5	5	10	115	140	95	156	10	212	11	4	12.8	-
63/B14	2.5	5	5.5	75	90	60	156	10	212	11	4	12.8	-
71/B5	4	4.5	11	130	160	110	157.5	12	213.5	14	5	16.3	-
71/B14	3	4.5	7	85	105	70	157.5	10	213.5	14	5	16.3	-
80/B5	4	5	12	165	200	130	172.5	12	228.5	19	6	21.8	13.5
80/B14	4	5	7	100	120	80	172.5	12	228.5	19	6	21.8	-
90/B5	4	5	12	165	200	130	172.5	12	228.5	24	8	27.3	13.5
90/B14	4	5	9	115	140	95	172.5	12	228.5	24	8	27.3	-

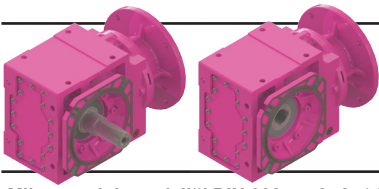

Ölçü Sayfaları

Dimension Pages

Abmessungsseiten

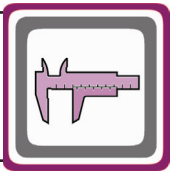

-Mil ucu çektirme deliği DIN 332 sayfa 2 / Tapped center hole to DIN 332, sheet 2 / Zentrierung mit Gewinde DIN 332, Blatt 2

KN002.02
KN003.02

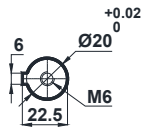
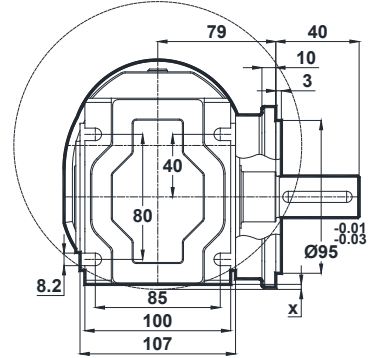
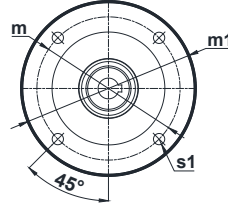
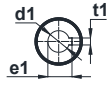
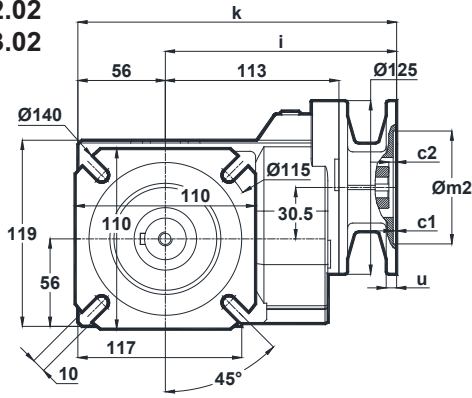

x: Motor Ayak bağlantı yüzeyinin altında ise
x: If Motor is lower than foot mounting plane
x: Wenn der Motor unter der Fußmontageebene ist

Opsiyonel flanş ölçüleri için sayfa 587'ye bakınız.
Please see on page 587 for optional flange dimensions
Siehe Seite 587 für auswählbare Flanschabmessungen

	c1	c2	s1	m	m1	m2	i	u	k	d1	t1	e1	x
63/B5	3.5	5	10	115	140	95	156	10	212	11	4	12.8	-
63/B14	2.5	5	5.5	75	90	60	156	10	212	11	4	12.8	-
71/B5	4	4.5	11	130	160	110	157.5	12	213.5	14	5	16.3	-
71/B14	3	4.5	7	85	105	70	157.5	10	213.5	14	5	16.3	-
80/B5	4	5	12	165	200	130	172.5	12	228.5	19	6	21.8	13.5
80/B14	4	5	7	100	120	80	172.5	12	228.5	19	6	21.8	-
90/B5	4	5	12	165	200	130	172.5	12	228.5	24	8	27.3	13.5
90/B14	4	5	9	115	140	95	172.5	12	228.5	24	8	27.3	-

KN002.03
KN003.03

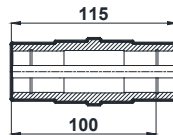
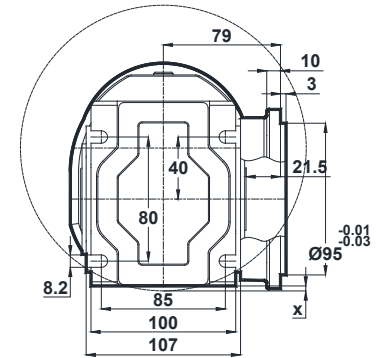
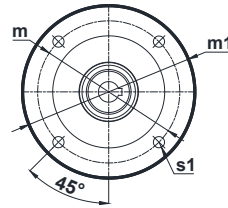
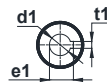
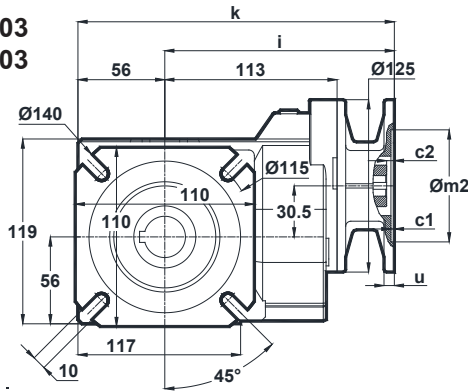

x: Motor Ayak bağlantı yüzeyinin altında ise
x: If Motor is lower than foot mounting plane
x: Wenn der Motor unter der Fußmontageebene ist

Opsiyonel flanş ölçüleri için sayfa 587'ye bakınız.
Please see on page 587 for optional flange dimensions
Siehe Seite 587 für auswählbare Flanschabmessungen

	c1	c2	s1	m	m1	m2	i	u	k	d1	t1	e1	x
63/B5	3.5	5	10	115	140	95	156	10	212	11	4	12.8	-
63/B14	2.5	5	5.5	75	90	60	156	10	212	11	4	12.8	-
71/B5	4	4.5	11	130	160	110	157.5	12	213.5	14	5	16.3	-
71/B14	3	4.5	7	85	105	70	157.5	10	213.5	14	5	16.3	-
80/B5	4	5	12	165	200	130	172.5	12	228.5	19	6	21.8	13.5
80/B14	4	5	7	100	120	80	172.5	12	228.5	19	6	21.8	-
90/B5	4	5	12	165	200	130	172.5	12	228.5	24	8	27.3	13.5
90/B14	4	5	9	115	140	95	172.5	12	228.5	24	8	27.3	-

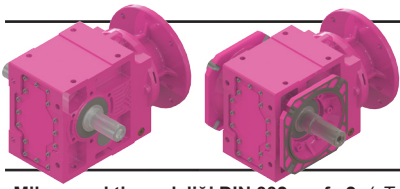

Ölçü Sayfaları

Dimension Pages

Abmessungsseiten

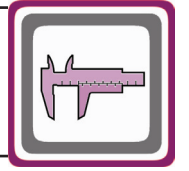

-Mil ucu çektirme deliği DIN 332 sayfa 2 / Tapped center hole to DIN 332, sheet 2 / Zentrierung mit Gewinde DIN 332, Blatt 2

KN002.04
KN003.04

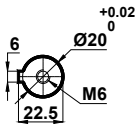
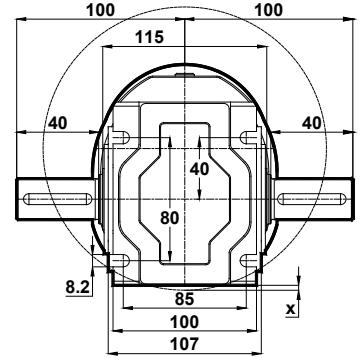
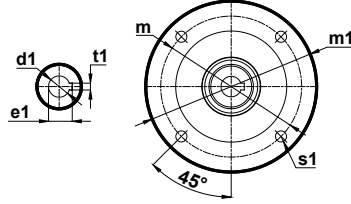
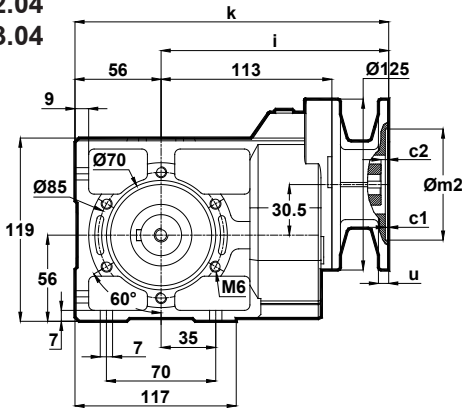

x: Motor Ayak bağlantı yüzeyinin altında ise
x: If Motor is lower than foot mounting plane
x: Wenn der Motor unter der Fußmontageebene ist

	c1	c2	s1	m	m1	m2	i	u	k	d1	t1	e1	x
63/B5	3.5	5	10	115	140	95	156	10	212	11	4	12.8	-
63/B14	2.5	5	5.5	75	90	60	60	10	212	11	4	12.8	-
71/B5	4	4.5	11	130	160	110	157.5	12	213.5	14	5	16.3	-
71/B14	3	4.5	7	85	105	70	70	10	213.5	14	5	16.3	-
80/B5	4	5	12	165	200	130	172.5	12	228.5	19	6	21.8	13.5
80/B14	4	5	7	100	120	80	80	12	228.5	19	6	21.8	-
90/B5	4	5	12	165	200	130	172.5	12	228.5	24	8	27.3	13.5
90/B14	4	5	9	115	140	95	95	12	228.5	24	8	27.3	-

KN002.05
KN003.05

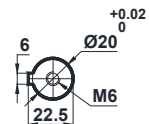
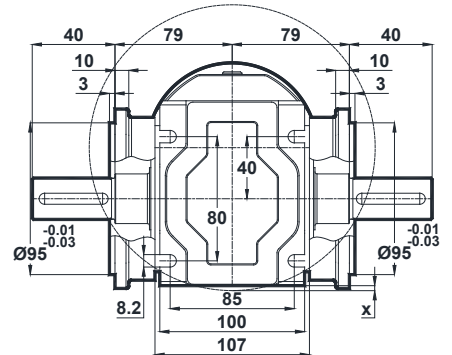
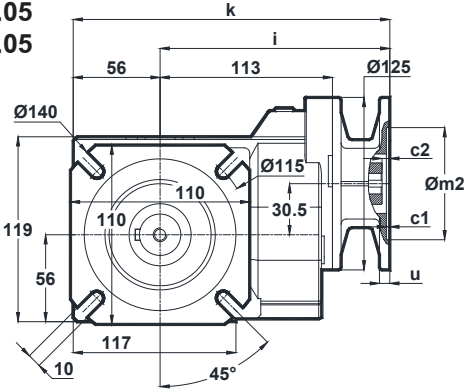

x: Motor Ayak bağlantı yüzeyinin altında ise
x: If Motor is lower than foot mounting plane
x: Wenn der Motor unter der Fußmontageebene ist

Opsiyonel flanş ölçüleri için sayfa 587'ye bakınız.
Please see on page 587 for optional flange dimensions
Siehe Seite 587 für auswählbare Flanschabmessungen

	c1	c2	s1	m	m1	m2	i	u	k	d1	t1	e1	x
63/B5	3.5	5	10	115	140	95	156	10	212	11	4	12.8	-
63/B14	2.5	5	5.5	75	90	60	60	10	212	11	4	12.8	-
71/B5	4	4.5	11	130	160	110	157.5	12	213.5	14	5	16.3	-
71/B14	3	4.5	7	85	105	70	70	10	213.5	14	5	16.3	-
80/B5	4	5	12	165	200	130	172.5	12	228.5	19	6	21.8	13.5
80/B14	4	5	7	100	120	80	80	12	228.5	19	6	21.8	-
90/B5	4	5	12	165	200	130	172.5	12	228.5	24	8	27.3	13.5
90/B14	4	5	9	115	140	95	95	12	228.5	24	8	27.3	-

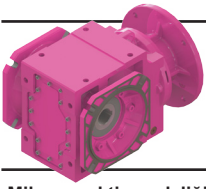

Ölçü Sayfaları Dimension Pages Abmessungsseiten

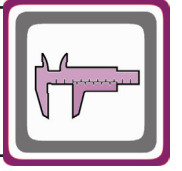

-Mil ucu çekirme deliği DIN 332 sayfa 2 / Tapped center hole to DIN 332, sheet 2 / Zentrierung mit Gewinde DIN 332, Blatt 2

KN002.08
KN003.08

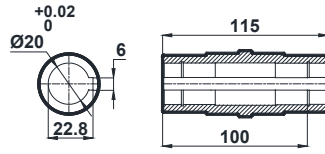
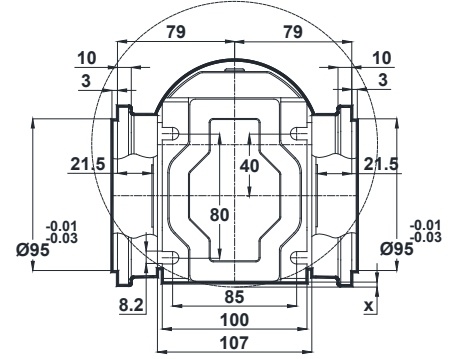
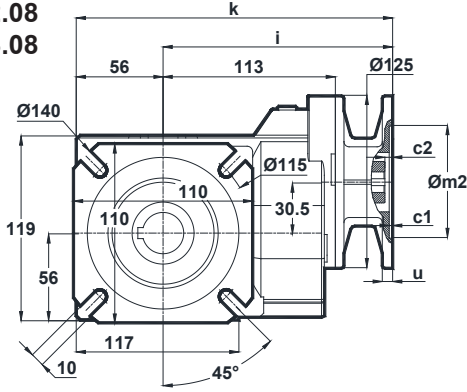

x: Motor Ayak bağlantı yüzeyinin altında ise
x: If Motor is lower than foot mounting plane
x: Wenn der Motor unter der Fußmontageebene ist

Opsiyonel flanş ölçüleri için sayfa 587'ye bakınız.
Please see on page 587 for optional flange dimensions
Siehe Seite 587 für auswählbare Flanschabmessungen

	c1	c2	s1	m	m1	m2	i	u	k	d1	t1	e1	x
63/B5	3.5	5	10	115	140	95	156	10	212	11	4	12.8	-
63/B14	2.5	5	5.5	75	90	60	60	10	212	11	4	12.8	-
71/B5	4	4.5	11	130	160	110	157.5	12	213.5	14	5	16.3	-
71/B14	3	4.5	7	85	105	70	70	10	213.5	14	5	16.3	-
80/B5	4	5	12	165	200	130	172.5	12	228.5	19	6	21.8	13.5
80/B14	4	5	7	100	120	80	80	12	228.5	19	6	21.8	-
90/B5	4	5	12	165	200	130	172.5	12	228.5	24	8	27.3	13.5
90/B14	4	5	9	115	140	95	95	12	228.5	24	8	27.3	-

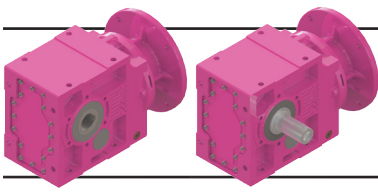

Ölçü Sayfaları

Dimension Pages

Abmessungsseiten

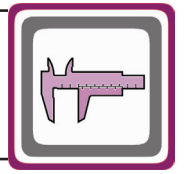

-Mil ucu çekirme deliği DIN 332 sayfa 2 / Tapped center hole to DIN 332, sheet 2 / Zentrierung mit Gewinde DIN 332, Blatt 2

KN102.00
KN103.00

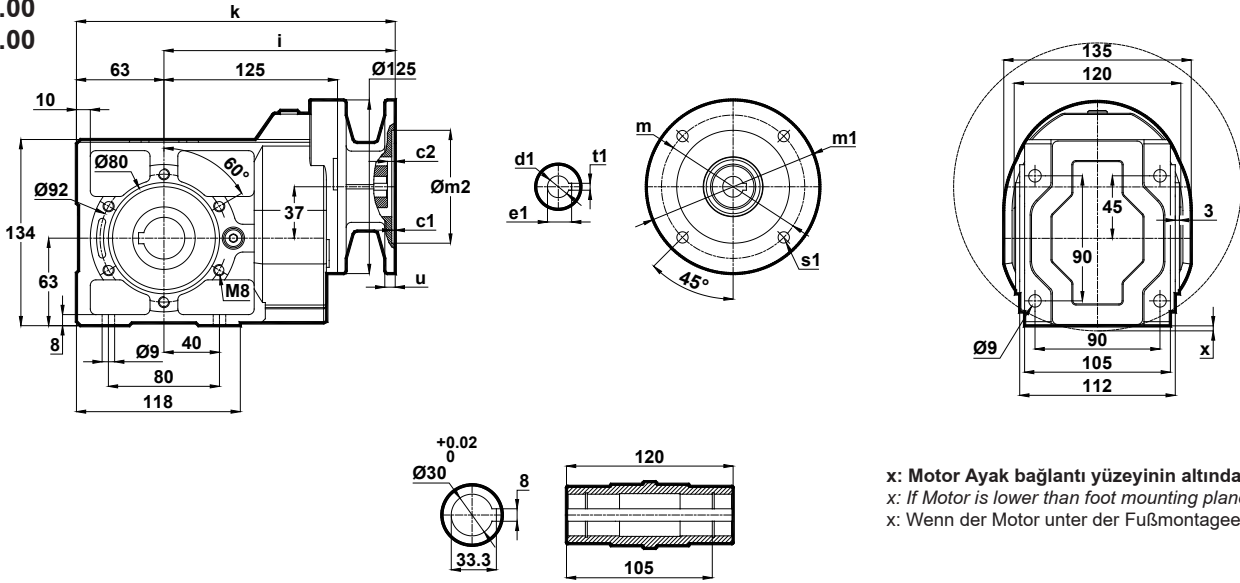

x: Motor Ayak bağlantı yüzeyinin altında ise
x: If Motor is lower than foot mounting plane
x: Wenn der Motor unter der Fußmontageebene ist

	c1	c2	s1	m	m1	m2	i	u	k	d1	t1	e1	x
63/B5	3.5	5	10	115	140	95	168	10	231	11	4	12.8	-
63/B14	2.5	5	5.5	75	90	60	168	10	231	11	4	12.8	-
71/B5	4	4.5	11	130	160	110	169.5	12	232.5	14	5	16.3	-
71/B14	3	4.5	7	85	105	70	169.5	10	232.5	14	5	16.3	-
80/B5	4	5	12	165	200	130	184.5	12	247.5	19	6	21.8	-
80/B14	4	5	7	100	120	80	184.5	12	247.5	19	6	21.8	-
90/B5	4	5	12	165	200	130	184.5	12	247.5	24	8	27.3	-
90/B14	4	5	9	115	140	95	184.5	12	247.5	24	8	27.3	-

KN102.01
KN103.01

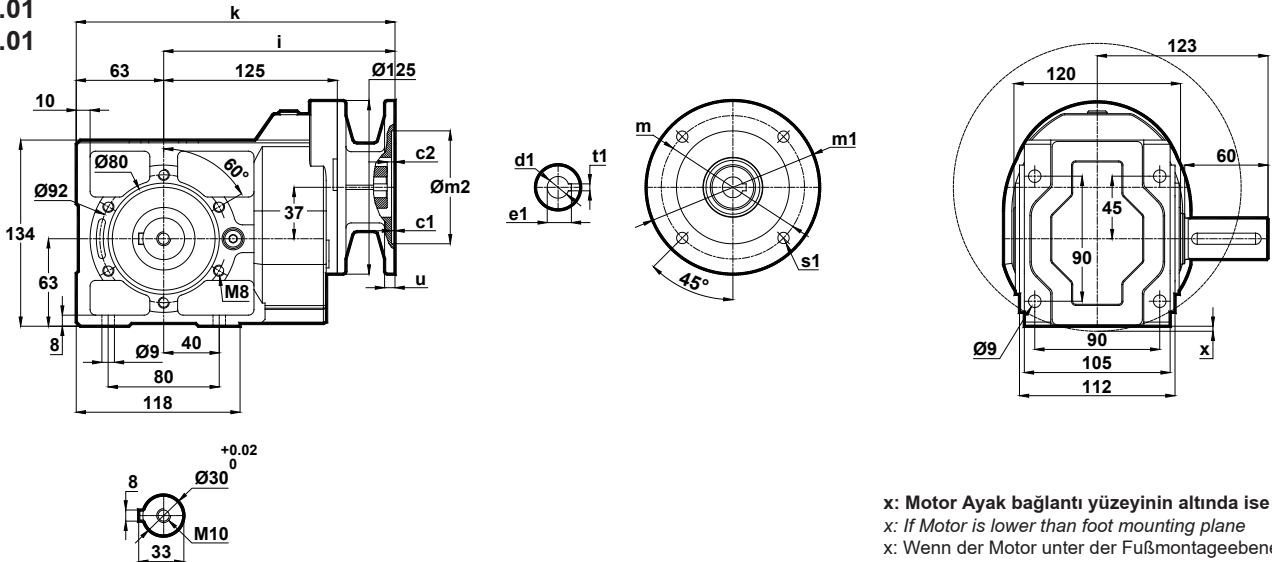

x: Motor Ayak bağlantı yüzeyinin altında ise
x: If Motor is lower than foot mounting plane
x: Wenn der Motor unter der Fußmontageebene ist

	c1	c2	s1	m	m1	m2	i	u	k	d1	t1	e1	x
63/B5	3.5	5	10	115	140	95	168	10	231	11	4	12.8	-
63/B14	2.5	5	5.5	75	90	60	168	10	231	11	4	12.8	-
71/B5	4	4.5	11	130	160	110	169.5	12	232.5	14	5	16.3	-
71/B14	3	4.5	7	85	105	70	169.5	10	232.5	14	5	16.3	-
80/B5	4	5	12	165	200	130	184.5	12	247.5	19	6	21.8	-
80/B14	4	5	7	100	120	80	184.5	12	247.5	19	6	21.8	-
90/B5	4	5	12	165	200	130	184.5	12	247.5	24	8	27.3	-
90/B14	4	5	9	115	140	95	184.5	12	247.5	24	8	27.3	-

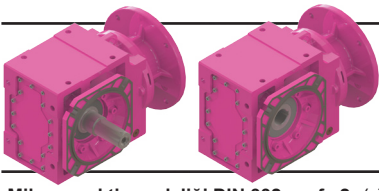

Ölçü Sayfaları

Dimension Pages

Abmessungsseiten

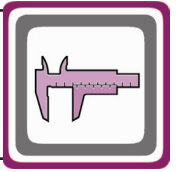

-Mil ucu çektirme deliği DIN 332 sayfa 2 / Tapped center hole to DIN 332, sheet 2 / Zentrierung mit Gewinde DIN 332, Blatt 2

KN102.02
KN103.02

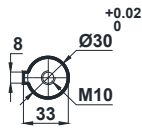
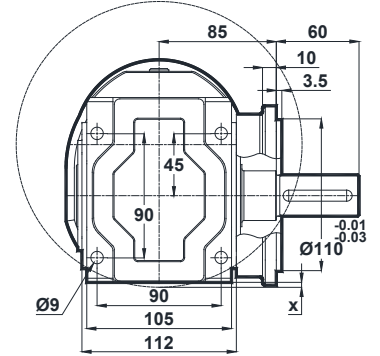
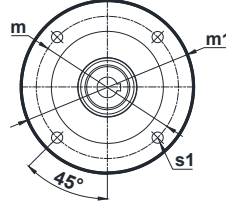
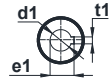
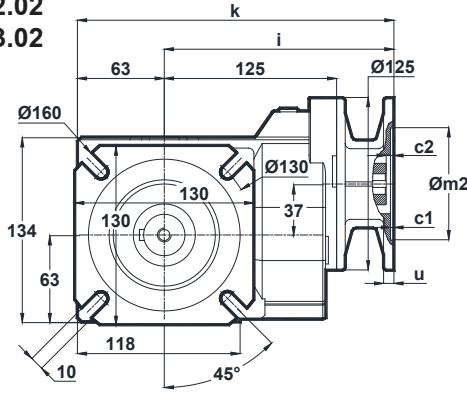

x: Motor Ayak bağlantı yüzeyinin altında ise
x: If Motor is lower than foot mounting plane
x: Wenn der Motor unter der Fußmontageebene ist

Opsiyonel flanş ölçüleri için sayfa 587'ye bakınız.
Please see on page 587 for optional flange dimensions
Siehe Seite 587 für auswählbare Flanschabmessungen

	c1	c2	s1	m	m1	m2	i	u	k	d1	t1	e1	x
63/B5	3.5	5	10	115	140	95	168	10	231	11	4	12.8	-
63/B14	2.5	5	5.5	75	90	60	168	10	231	11	4	12.8	-
71/B5	4	4.5	11	130	160	110	169.5	12	232.5	14	5	16.3	-
71/B14	3	4.5	7	85	105	70	169.5	10	232.5	14	5	16.3	-
80/B5	4	5	12	165	200	130	184.5	12	247.5	19	6	21.8	-
80/B14	4	5	7	100	120	80	184.5	12	247.5	19	6	21.8	-
90/B5	4	5	12	165	200	130	184.5	12	247.5	24	8	27.3	-
90/B14	4	5	9	115	140	95	184.5	12	247.5	24	8	27.3	-

KN102.03
KN103.03

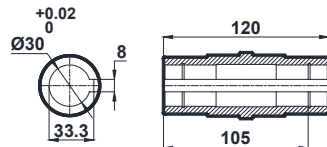
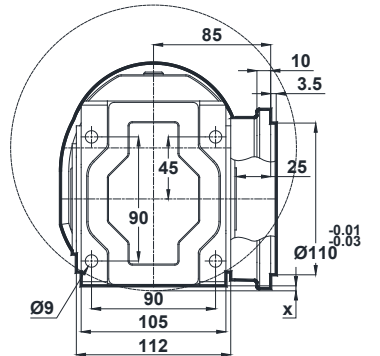
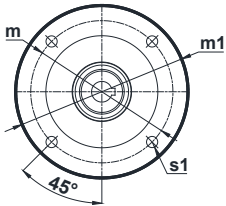
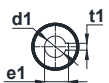
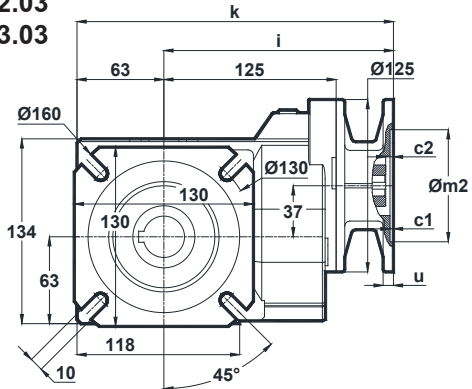

x: Motor Ayak bağlantı yüzeyinin altında ise
x: If Motor is lower than foot mounting plane
x: Wenn der Motor unter der Fußmontageebene ist

Opsiyonel flanş ölçüleri için sayfa 587'ye bakınız.
Please see on page 587 for optional flange dimensions
Siehe Seite 587 für auswählbare Flanschabmessungen

	c1	c2	s1	m	m1	m2	i	u	k	d1	t1	e1	x
63/B5	3.5	5	10	115	140	95	168	10	231	11	4	12.8	-
63/B14	2.5	5	5.5	75	90	60	168	10	231	11	4	12.8	-
71/B5	4	4.5	11	130	160	110	169.5	12	232.5	14	5	16.3	-
71/B14	3	4.5	7	85	105	70	169.5	10	232.5	14	5	16.3	-
80/B5	4	5	12	165	200	130	184.5	12	247.5	19	6	21.8	-
80/B14	4	5	7	100	120	80	184.5	12	247.5	19	6	21.8	-
90/B5	4	5	12	165	200	130	184.5	12	247.5	24	8	27.3	-
90/B14	4	5	9	115	140	95	184.5	12	247.5	24	8	27.3	-

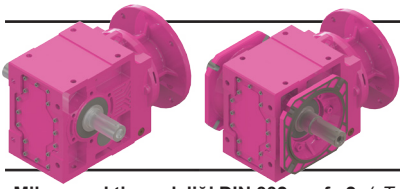

Ölçü Sayfaları

Dimension Pages

Abmessungsseiten

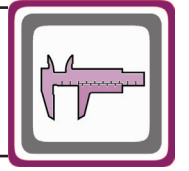

-Mil ucu çektirme deliği DIN 332 sayfa 2 / Tapped center hole to DIN 332, sheet 2 / Zentrierung mit Gewinde DIN 332, Blatt 2

KN102.04
KN103.04

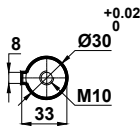
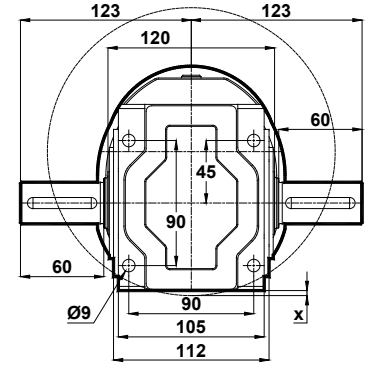
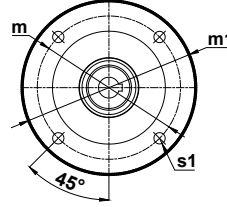
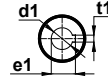
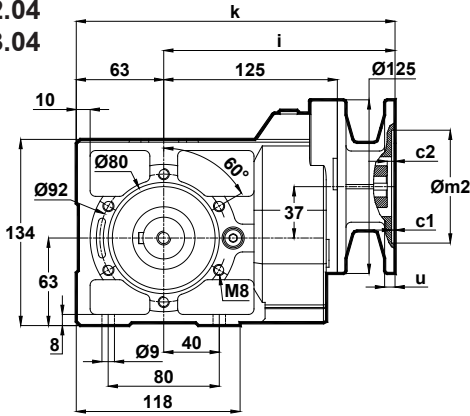

x: Motor Ayak bağlantı yüzeyinin altında ise
x: If Motor is lower than foot mounting plane
x: Wenn der Motor unter der Fußmontageebene ist

	c1	c2	s1	m	m1	m2	i	u	k	d1	t1	e1	x
63/B5	3.5	5	10	115	140	95	168	10	231	11	4	12.8	-
63/B14	2.5	5	5.5	75	90	60	168	10	231	11	4	12.8	-
71/B5	4	4.5	11	130	160	110	169.5	12	232.5	14	5	16.3	-
71/B14	3	4.5	7	85	105	70	169.5	10	232.5	14	5	16.3	-
80/B5	4	5	12	165	200	130	184.5	12	247.5	19	6	21.8	-
80/B14	4	5	7	100	120	80	184.5	12	247.5	19	6	21.8	-
90/B5	4	5	12	165	200	130	184.5	12	247.5	24	8	27.3	-
90/B14	4	5	9	115	140	95	184.5	12	247.5	24	8	27.3	-

KN102.05
KN103.05

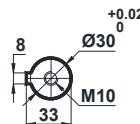
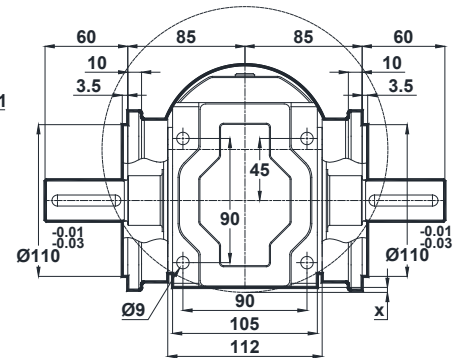
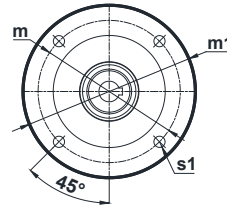
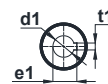
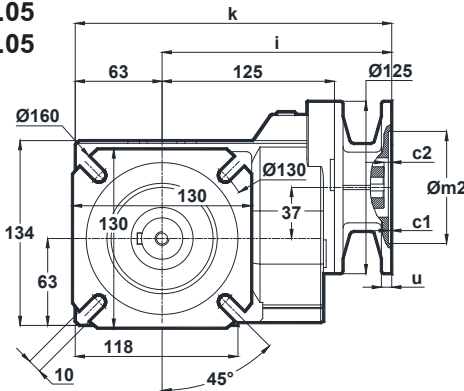

x: Motor Ayak bağlantı yüzeyinin altında ise
x: If Motor is lower than foot mounting plane
x: Wenn der Motor unter der Fußmontageebene ist

Opsiyonel flanş ölçüleri için sayfa 587'ye bakınız.
Please see on page 587 for optional flange dimensions
Siehe Seite 587 für auswählbare Flanschabmessungen

	c1	c2	s1	m	m1	m2	i	u	k	d1	t1	e1	x
63/B5	3.5	5	10	115	140	95	168	10	231	11	4	12.8	-
63/B14	2.5	5	5.5	75	90	60	168	10	231	11	4	12.8	-
71/B5	4	4.5	11	130	160	110	169.5	12	232.5	14	5	16.3	-
71/B14	3	4.5	7	85	105	70	169.5	10	232.5	14	5	16.3	-
80/B5	4	5	12	165	200	130	184.5	12	247.5	19	6	21.8	-
80/B14	4	5	7	100	120	80	184.5	12	247.5	19	6	21.8	-
90/B5	4	5	12	165	200	130	184.5	12	247.5	24	8	27.3	-
90/B14	4	5	9	115	140	95	184.5	12	247.5	24	8	27.3	-

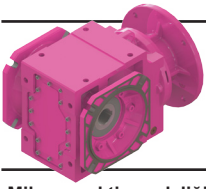

Ölçü Sayfaları Dimension Pages Abmessungenseiten

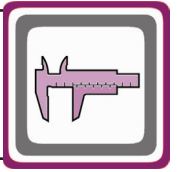

-Mil ucu çekirme deliği DIN 332 sayfa 2 / Tapped center hole to DIN 332, sheet 2 / Zentrierung mit Gewinde DIN 332, Blatt 2

KN102.08
KN103.08

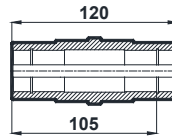
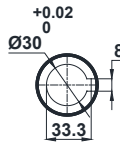
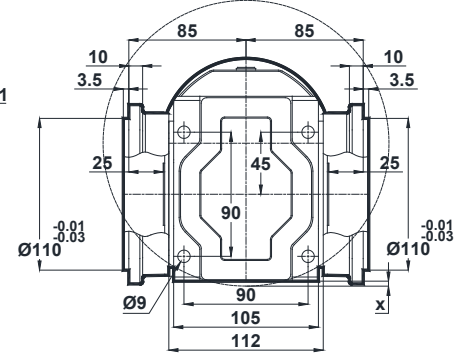
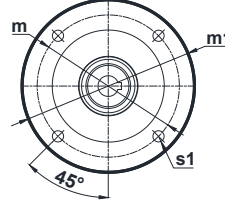
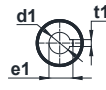
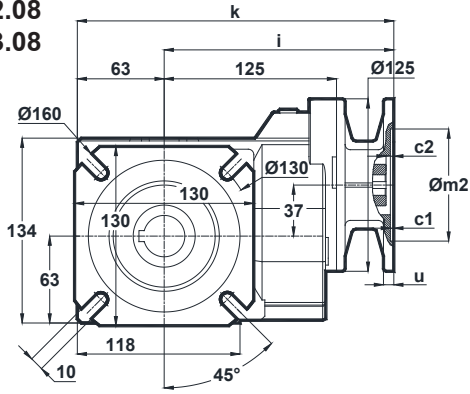

x: Motor Ayak bağlantı yüzeyinin altında ise
x: If Motor is lower than foot mounting plane
x: Wenn der Motor unter der Fußmontageebene ist

Opsiyonel flanş ölçüleri için sayfa 587'ye bakınız.
Please see on page 587 for optional flange dimensions
Siehe Seite 587 für auswählbare Flanschabmessungen

	c1	c2	s1	m	m1	m2	i	u	k	d1	t1	e1	x
63/B5	3.5	5	10	115	140	95	168	10	231	11	4	12.8	-
63/B14	2.5	5	5.5	75	90	60	169.5	12	232.5	14	5	16.3	-
71/B5	4	4.5	11	130	160	110	184.5	12	247.5	19	6	21.8	-
71/B14	3	4.5	7	85	105	70	184.5	12	247.5	24	8	27.3	-
80/B5	4	5	12	165	200	130	184.5	12	247.5	24	8	27.3	-
80/B14	4	5	7	100	120	80	184.5	12	247.5	24	8	27.3	-
90/B5	4	5	12	165	200	130	184.5	12	247.5	24	8	27.3	-
90/B14	4	5	9	115	140	95	184.5	12	247.5	24	8	27.3	-

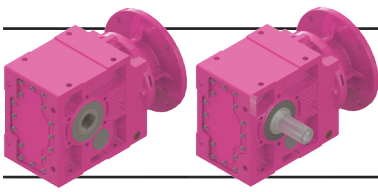

Ölçü Sayfaları

Dimension Pages

Abmessungsseiten

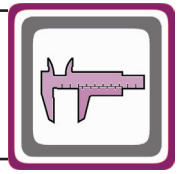

-Mil ucu çekirme deliği DIN 332 sayfa 2 / Tapped center hole to DIN 332, sheet 2 / Zentrierung mit Gewinde DIN 332, Blatt 2

KN202.00
KN203.00

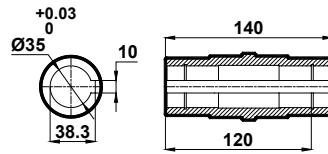
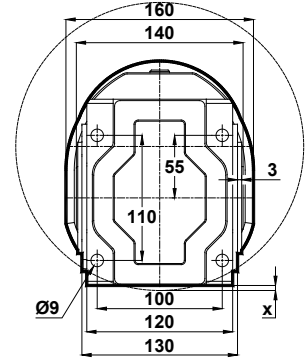
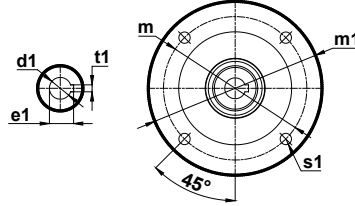
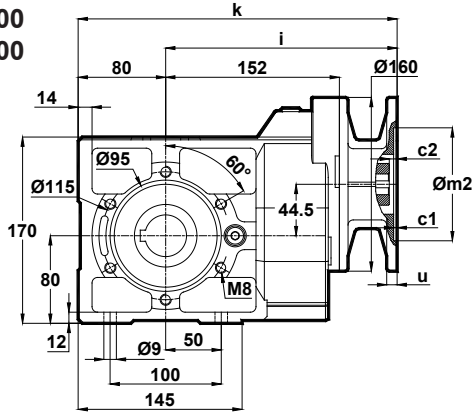

x: Motor Ayak bağlantı yüzeyinin altında ise
x: If Motor is lower than foot mounting plane
x: Wenn der Motor unter der Fußmontageebene ist

	c1	c2	s1	m	m1	m2	i	u	k	d1	t1	e1	x
63/B5	3.5	5	9	115	140	95	225.5	12	305.5	11	4	12.8	-
71/B5	4	8.5	11	130	160	110	196.5	12	276.5	14	5	16.3	-
71/B14	3		7	85	105	70		10					
80/B5	4	5	12	165	200	130	225.5	12	305.5	19	6	21.8	-
80/B14			7	100	120	80							
90/B5	4	5	12	165	200	130	225.5	12	305.5	24	8	27.3	-
90/B14			9	115	140	95							
100/B5	4.5	5.5	15	215	250	180	218.5	12	298.5	28	8	31.3	0.5
100/B14	4		9	130	160	110							
112/B5	4.5	5.5	15	215	250	180	218.5	12	298.5	28	8	31.3	0.5
112/B14	4		9	130	160	110							

KN202.01
KN203.01

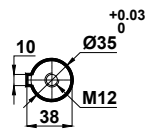
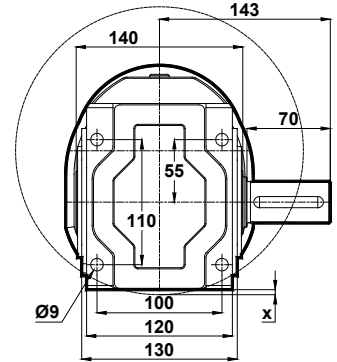
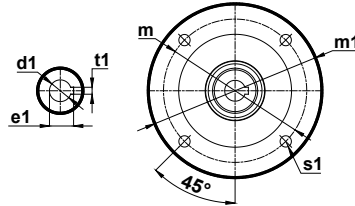
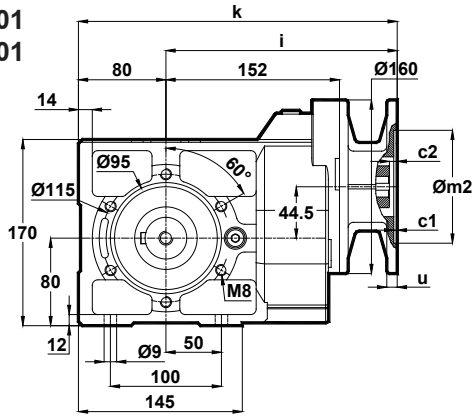

x: Motor Ayak bağlantı yüzeyinin altında ise
x: If Motor is lower than foot mounting plane
x: Wenn der Motor unter der Fußmontageebene ist

	c1	c2	s1	m	m1	m2	i	u	k	d1	t1	e1	x
63/B5	3.5	5	9	115	140	95	225.5	12	305.5	11	4	12.8	-
71/B5	4	8.5	11	130	160	110	196.5	12	276.5	14	5	16.3	-
71/B14	3		7	85	105	70		10					
80/B5	4	5	12	165	200	130	225.5	12	305.5	19	6	21.8	-
80/B14			7	100	120	80							
90/B5	4	5	12	165	200	130	225.5	12	305.5	24	8	27.3	-
90/B14			9	115	140	95							
100/B5	4.5	5.5	15	215	250	180	218.5	12	298.5	28	8	31.3	0.5
100/B14	4		9	130	160	110							
112/B5	4.5	5.5	15	215	250	180	218.5	12	298.5	28	8	31.3	0.5
112/B14	4		9	130	160	110							

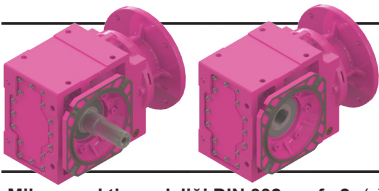

Ölçü Sayfaları

Dimension Pages

Abmessungsseiten

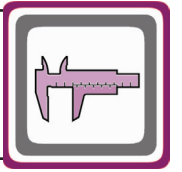

-Mil ucu çekirme deliği DIN 332 sayfa 2 / Tapped center hole to DIN 332, sheet 2 / Zentrierung mit Gewinde DIN 332, Blatt 2

KN202.02
KN203.02

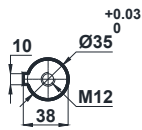
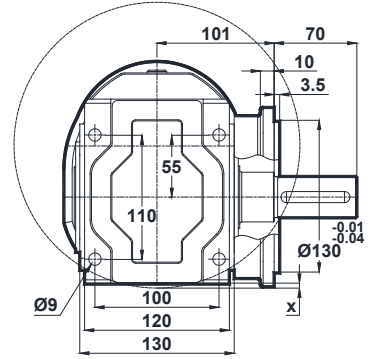
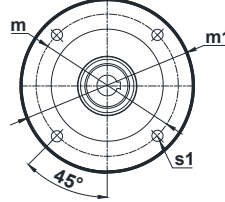
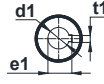
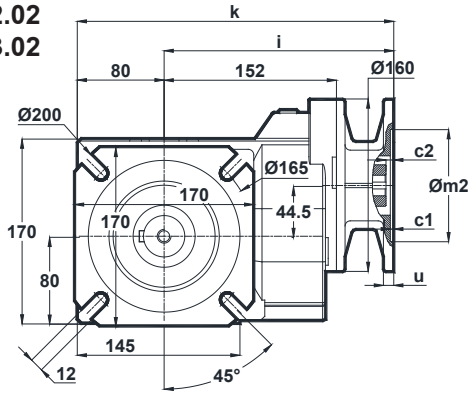

x: Motor Ayak bağlantı yüzeyinin altında ise
x: If Motor is lower than foot mounting plane
x: Wenn der Motor unter der Fußmontageebene ist

Opsiyonel flanş ölçüleri için sayfa 587'ye bakınız.
Please see on page 587 for optional flange dimensions
Siehe Seite 587 für auswählbare Flanschabmessungen

	c1	c2	s1	m	m1	m2	i	u	k	d1	t1	e1	x
63/B5	3.5	5	9	115	140	95	225.5	12	305.5	11	4	12.8	-
71/B5	4	8.5	11	130	160	110	196.5	12	276.5	14	5	16.3	-
71/B14	3		7	85	105	70		10					
80/B5	4	5	12	165	200	130	225.5	12	305.5	19	6	21.8	-
80/B14			7	100	120	80							
90/B5	4	5	12	165	200	130	225.5	12	305.5	24	8	27.3	-
90/B14			9	115	140	95							
100/B5	4.5	5.5	15	215	250	180	218.5	12	298.5	28	8	31.3	0.5
100/B14	4		9	130	160	110							-
112/B5	4.5	5.5	15	215	250	180	218.5	12	298.5	28	8	31.3	0.5
112/B14	4		9	130	160	110							-

KN202.03
KN203.03

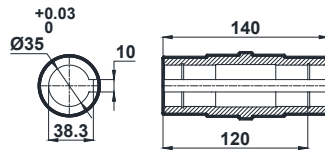
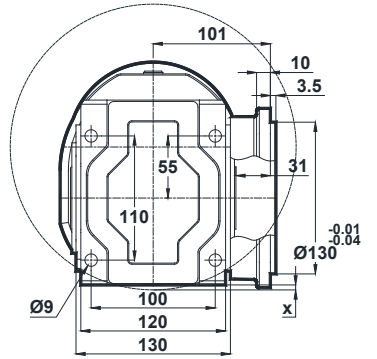
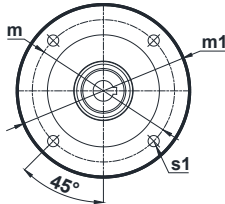
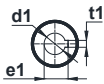
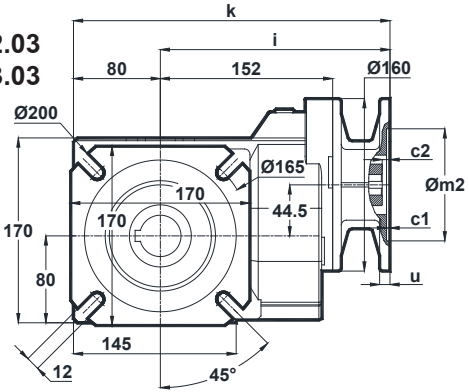

x: Motor Ayak bağlantı yüzeyinin altında ise
x: If Motor is lower than foot mounting plane
x: Wenn der Motor unter der Fußmontageebene ist

Opsiyonel flanş ölçüleri için sayfa 587'ye bakınız.
Please see on page 587 for optional flange dimensions
Siehe Seite 587 für auswählbare Flanschabmessungen

	c1	c2	s1	m	m1	m2	i	u	k	d1	t1	e1	x
63/B5	3.5	5	9	115	140	95	225.5	12	305.5	11	4	12.8	-
71/B5	4	8.5	11	130	160	110	196.5	12	276.5	14	5	16.3	-
71/B14	3		7	85	105	70		10					
80/B5	4	5	12	165	200	130	225.5	12	305.5	19	6	21.8	-
80/B14			7	100	120	80							
90/B5	4	5	12	165	200	130	225.5	12	305.5	24	8	27.3	-
90/B14			9	115	140	95							
100/B5	4.5	5.5	15	215	250	180	218.5	12	298.5	28	8	31.3	0.5
100/B14	4		9	130	160	110							-
112/B5	4.5	5.5	15	215	250	180	218.5	12	298.5	28	8	31.3	0.5
112/B14	4		9	130	160	110							-

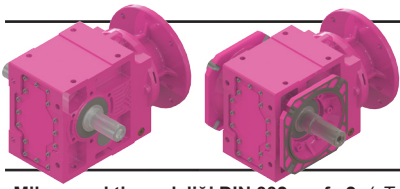

Ölçü Sayfaları

Dimension Pages

Abmessungsseiten

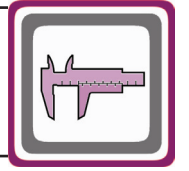

-Mil ucu çekirme deliği DIN 332 sayfa 2 / Tapped center hole to DIN 332, sheet 2 / Zentrierung mit Gewinde DIN 332, Blatt 2

KN202.04
KN203.04

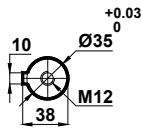
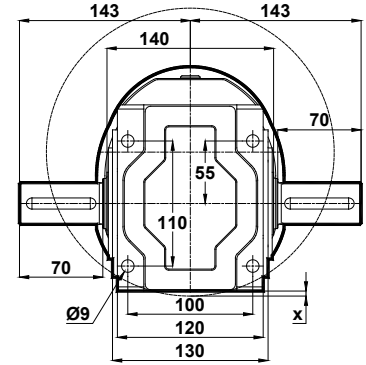
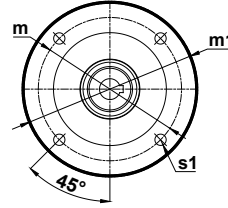
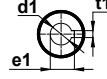
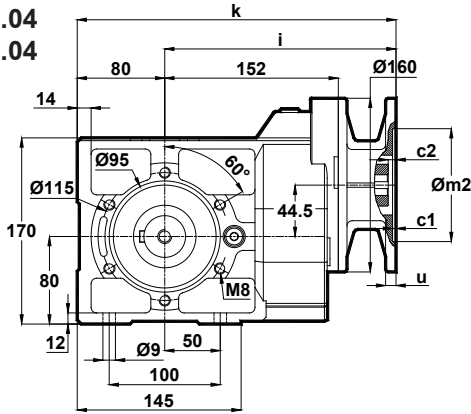

x: Motor Ayak bağlantı yüzeyinin altında ise
x: If Motor is lower than foot mounting plane
x: Wenn der Motor unter der Fußmontageebene ist

	c1	c2	s1	m	m1	m2	i	u	k	d1	t1	e1	x
63/B5	3.5	5	9	115	140	95	225.5	12	305.5	11	4	12.8	-
71/B5	4	8.5	11	130	160	110	196.5	12	276.5	14	5	16.3	-
71/B14	3		7	85	105	70		10					
80/B5	4	5	12	165	200	130	225.5	12	305.5	19	6	21.8	-
80/B14			7	100	120	80							
90/B5	4	5	12	165	200	130	225.5	12	305.5	24	8	27.3	-
90/B14			9	115	140	95							
100/B5	4.5	5.5	15	215	250	180	218.5	12	298.5	28	8	31.3	0.5
100/B14	4		9	130	160	110							
112/B5	4.5	5.5	15	215	250	180	218.5	12	298.5	28	8	31.3	0.5
112/B14	4		9	130	160	110							

KN202.05
KN203.05

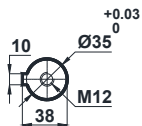
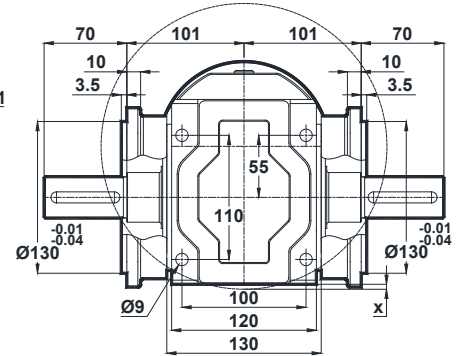
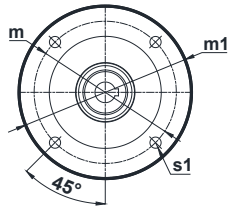
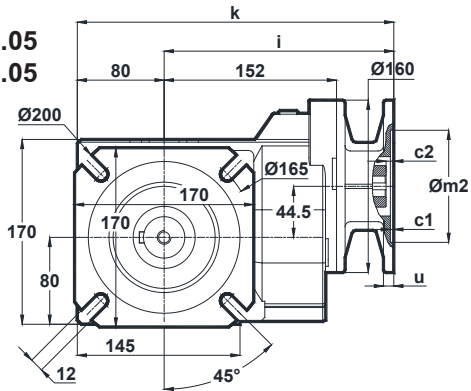

x: Motor Ayak bağlantı yüzeyinin altında ise
x: If Motor is lower than foot mounting plane
x: Wenn der Motor unter der Fußmontageebene ist

Opsiyonel flanş ölçüleri için sayfa 587'ye bakınız.
Please see on page 587 for optional flange dimensions
Siehe Seite 587 für auswählbare Flanschabmessungen

	c1	c2	s1	m	m1	m2	i	u	k	d1	t1	e1	x
63/B5	3.5	5	9	115	140	95	225.5	12	305.5	11	4	12.8	-
71/B5	4	8.5	11	130	160	110	196.5	12	276.5	14	5	16.3	-
71/B14	3		7	85	105	70		10					
80/B5	4	5	12	165	200	130	225.5	12	305.5	19	6	21.8	-
80/B14			7	100	120	80							
90/B5	4	5	12	165	200	130	225.5	12	305.5	24	8	27.3	-
90/B14			9	115	140	95							
100/B5	4.5	5.5	15	215	250	180	218.5	12	298.5	28	8	31.3	0.5
100/B14	4		9	130	160	110							
112/B5	4.5	5.5	15	215	250	180	218.5	12	298.5	28	8	31.3	0.5
112/B14	4		9	130	160	110							

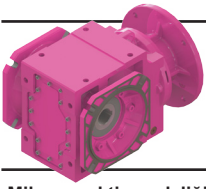

Ölçü Sayfaları Dimension Pages Abmessungsseiten

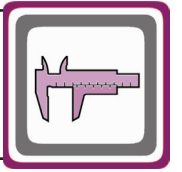

-Mil ucu çekirme deliği DIN 332 sayfa 2 / Tapped center hole to DIN 332, sheet 2 / Zentrierung mit Gewinde DIN 332, Blatt 2

KN202.08
KN203.08

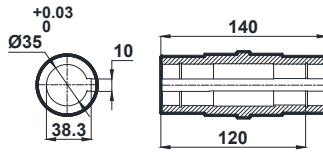
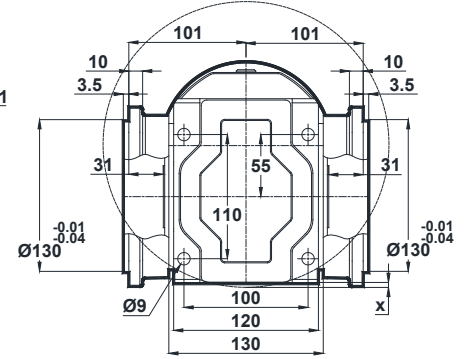
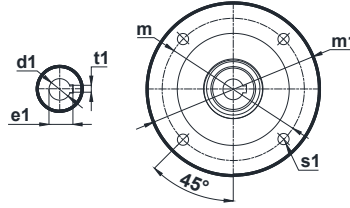
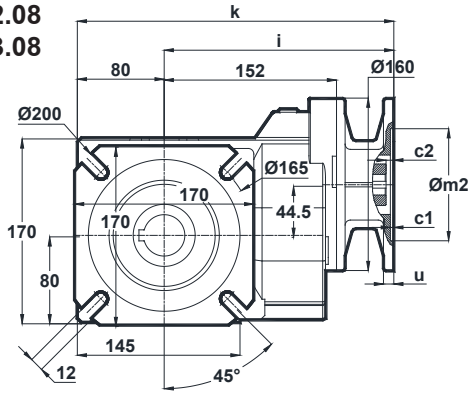

x: Motor Ayak bağlantı yüzeyinin altında ise
x: If Motor is lower than foot mounting plane
x: Wenn der Motor unter der Fußmontageebene ist

Opsiyonel flanş ölçüleri için sayfa 587'ye bakınız.
Please see on page 587 for optional flange dimensions
Siehe Seite 587 für auswählbare Flanschabmessungen

	c1	c2	s1	m	m1	m2	i	u	k	d1	t1	e1	x
63/B5	3.5	5	9	115	140	95	225.5	12	305.5	11	4	12.8	-
71/B5	4	8.5	11	130	160	110	196.5	12	276.5	14	5	16.3	-
71/B14	3		7	85	105	70		10					
80/B5	4	5	12	165	200	130	225.5	12	305.5	19	6	21.8	-
80/B14			7	100	120	80							
90/B5	4	5	12	165	200	130	225.5	12	305.5	24	8	27.3	-
90/B14			9	115	140	95							
100/B5	4.5	5.5	15	215	250	180	218.5	12	298.5	28	8	31.3	0.5
100/B14	4		9	130	160	110							-
112/B5	4.5	5.5	15	215	250	180	218.5	12	298.5	28	8	31.3	0.5
112/B14	4		9	130	160	110							-

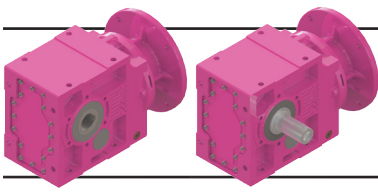

Ölçü Sayfaları

Dimension Pages

Abmessungsseiten

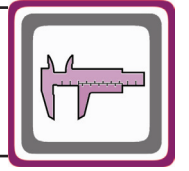

-Mil ucu çekirme deliği DIN 332 sayfa 2 / Tapped center hole to DIN 332, sheet 2 / Zentrierung mit Gewinde DIN 332, Blatt 2

KN273.00

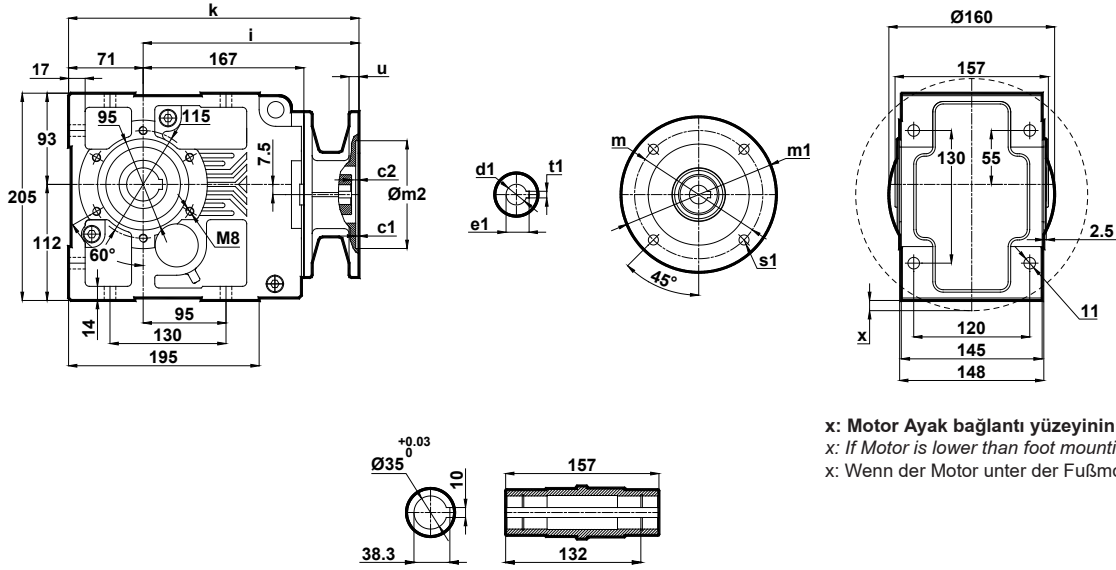

x: Motor Ayak bağlantı yüzeyinin altında ise
 x: If Motor is lower than foot mounting plane
 x: Wenn der Motor unter der Fußmontageebene ist

	c1	c2	s1	m	m1	m2	i	u	k	d1	t1	e1	x
63/B5	3.5	5	9	115	140	95	240.5	12	311.5	11	4	12.8	-
71/B5	4	8.5	11	130	160	110	211.5	12	282.5	14	5	16.3	-
71/B14	3		7	85	105	70		10					
80/B5	4	5	12	165	200	130	240.5	12	311.5	19	6	21.8	-
80/B14			7	100	120	80							
90/B5	4	5	12	165	200	130	240.5	12	311.5	24	8	27.3	-
90/B14			9	115	140	95							
100/B5	4.5	5.5	15	215	250	180	233.5	12	304.5	28	8	31.3	20.5
100/B14	4		9	130	160	110							-
112/B5	4.5	5.5	15	215	250	180	233.5	12	304.5	28	8	31.3	20.5
112/B14	4		9	130	160	110							-

KN273.01

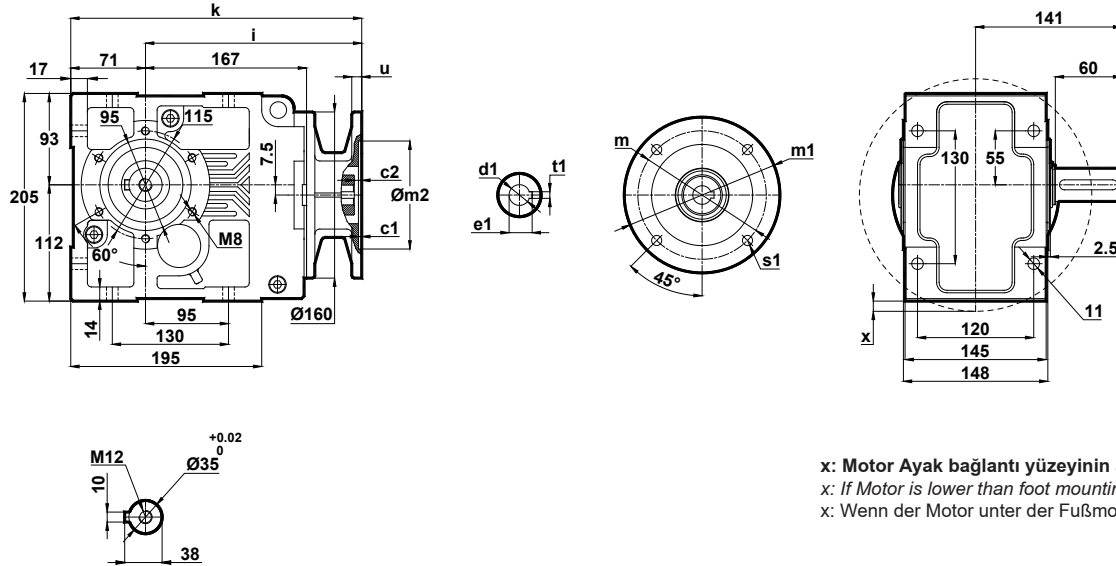

x: Motor Ayak bağlantı yüzeyinin altında ise
 x: If Motor is lower than foot mounting plane
 x: Wenn der Motor unter der Fußmontageebene ist

	c1	c2	s1	m	m1	m2	i	u	k	d1	t1	e1	x
63/B5	3.5	5	9	115	140	95	240.5	12	311.5	11	4	12.8	-
71/B5	4	8.5	11	130	160	110	211.5	12	282.5	14	5	16.3	-
71/B14	3		7	85	105	70		10					
80/B5	4	5	12	165	200	130	240.5	12	311.5	19	6	21.8	-
80/B14			7	100	120	80							
90/B5	4	5	12	165	200	130	240.5	12	311.5	24	8	27.3	-
90/B14			9	115	140	95							
100/B5	4.5	5.5	15	215	250	180	233.5	12	304.5	28	8	31.3	20.5
100/B14	4		9	130	160	110							-
112/B5	4.5	5.5	15	215	250	180	233.5	12	304.5	28	8	31.3	20.5
112/B14	4		9	130	160	110							-

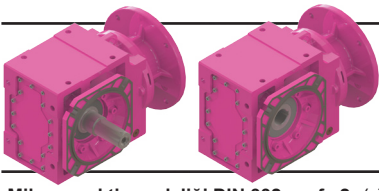

Ölçü Sayfaları

Dimension Pages

Abmessungsseiten

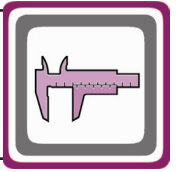

-Mil ucu çektirme deliği DIN 332 sayfa 2 / Tapped center hole to DIN 332, sheet 2 / Zentrierung mit Gewinde DIN 332, Blatt 2

KN273.02

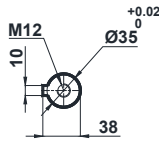
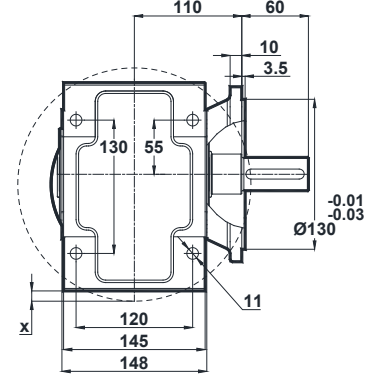
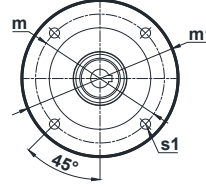
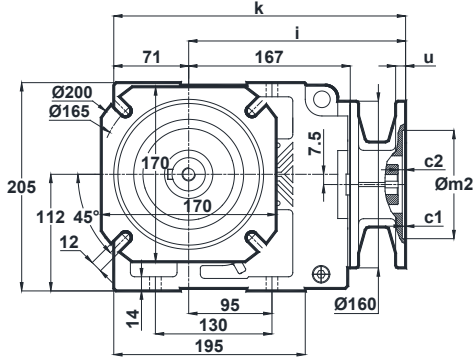

x: Motor Ayak bağlantı yüzeyinin altında ise
x: If Motor is lower than foot mounting plane
x: Wenn der Motor unter der Fußmontageebene ist

Opsiyonel flanş ölçüleri için sayfa 587'ye bakınız.
Please see on page 587 for optional flange dimensions
Siehe Seite 587 für auswählbare Flanschabmessungen

	c1	c2	s1	m	m1	m2	i	u	k	d1	t1	e1	x
63/B5	3.5	5	9	115	140	95	240.5	12	311.5	11	4	12.8	-
71/B5	4	8.5	11	130	160	110	211.5	12	282.5	14	5	16.3	-
71/B14	3		7	85	105	70		10					
80/B5	4	5	12	165	200	130	240.5	12	311.5	19	6	21.8	-
80/B14			7	100	120	80							
90/B5	4	5	12	165	200	130	240.5	12	311.5	24	8	27.3	-
90/B14			9	115	140	95							
100/B5	4.5	5.5	15	215	250	180	233.5	12	304.5	28	8	31.3	20.5
100/B14	4		9	130	160	110							-
112/B5	4.5	5.5	15	215	250	180	233.5	12	304.5	28	8	31.3	20.5
112/B14	4		9	130	160	110							-

KN273.03

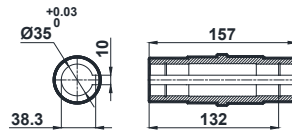
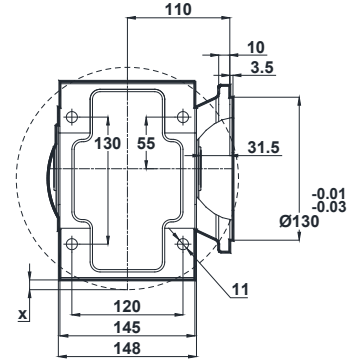
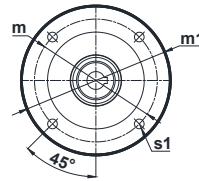
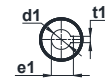
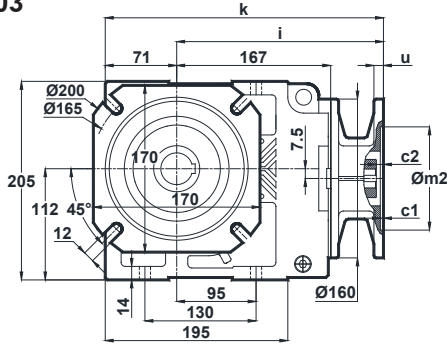

x: Motor Ayak bağlantı yüzeyinin altında ise
x: If Motor is lower than foot mounting plane
x: Wenn der Motor unter der Fußmontageebene ist

Opsiyonel flanş ölçüleri için sayfa 587'ye bakınız.
Please see on page 587 for optional flange dimensions
Siehe Seite 587 für auswählbare Flanschabmessungen

	c1	c2	s1	m	m1	m2	i	u	k	d1	t1	e1	x
63/B5	3.5	5	9	115	140	95	240.5	12	311.5	11	4	12.8	-
71/B5	4	8.5	11	130	160	110	211.5	12	282.5	14	5	16.3	-
71/B14	3		7	85	105	70		10					
80/B5	4	5	12	165	200	130	240.5	12	311.5	19	6	21.8	-
80/B14			7	100	120	80							
90/B5	4	5	12	165	200	130	240.5	12	311.5	24	8	27.3	-
90/B14			9	115	140	95							
100/B5	4.5	5.5	15	215	250	180	233.5	12	304.5	28	8	31.3	20.5
100/B14	4		9	130	160	110							-
112/B5	4.5	5.5	15	215	250	180	233.5	12	304.5	28	8	31.3	20.5
112/B14	4		9	130	160	110							-

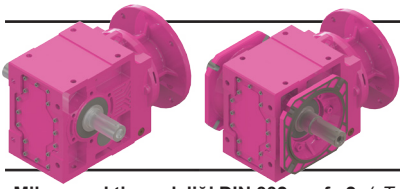

Ölçü Sayfaları

Dimension Pages

Abmessungsseiten

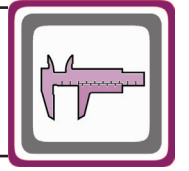

-Mil ucu çektirme deliği DIN 332 sayfa 2 / Tapped center hole to DIN 332, sheet 2 / Zentrierung mit Gewinde DIN 332, Blatt 2

KN273.04

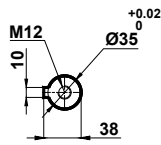
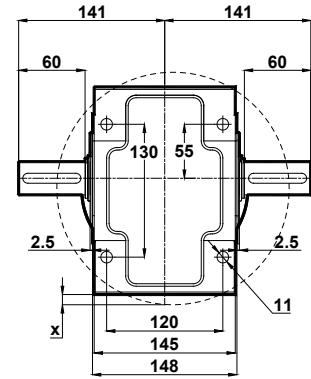
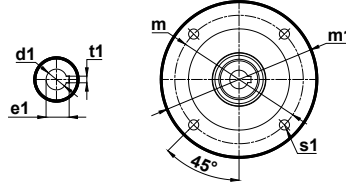
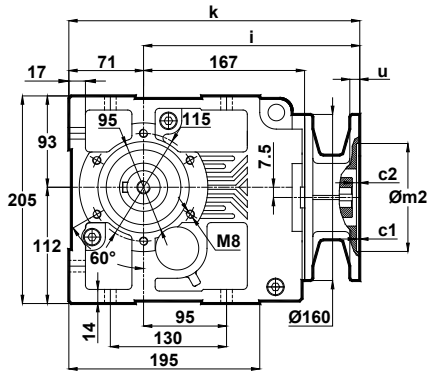

x: Motor Ayak bağlantı yüzeyinin altında ise
x: If Motor is lower than foot mounting plane
x: Wenn der Motor unter der Fußmontageebene ist

	c1	c2	s1	m	m1	m2	i	u	k	d1	t1	e1	x
63/B5	3.5	5	9	115	140	95	240.5	12	311.5	11	4	12.8	-
71/B5	4	8.5	11	130	160	110	211.5	12	282.5	14	5	16.3	-
71/B14	3	8.5	7	85	105	70	211.5	10	282.5	14	5	16.3	-
80/B5	4	5	12	165	200	130	240.5	12	311.5	19	6	21.8	-
80/B14	4	5	7	100	120	80	240.5	12	311.5	19	6	21.8	-
90/B5	4	5	12	165	200	130	240.5	12	311.5	24	8	27.3	-
90//B14	4	5	9	115	140	95	240.5	12	311.5	24	8	27.3	-
100/B5	4.5	5.5	15	215	250	180	233.5	12	304.5	28	8	31.3	20.5
100/B14	4	5.5	9	130	160	110	233.5	12	304.5	28	8	31.3	-
112/B5	4.5	5.5	15	215	250	180	233.5	12	304.5	28	8	31.3	20.5
112/B14	4	5.5	9	130	160	110	233.5	12	304.5	28	8	31.3	-

KN273.05

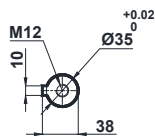
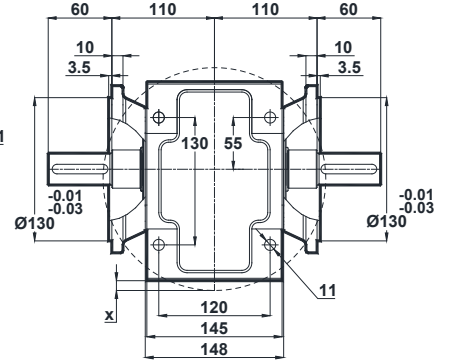
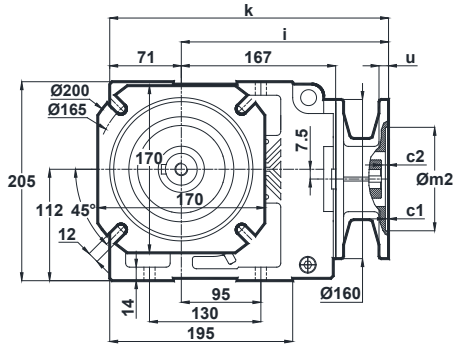

x: Motor Ayak bağlantı yüzeyinin altında ise
x: If Motor is lower than foot mounting plane
x: Wenn der Motor unter der Fußmontageebene ist

Opsiyonel flanş ölçüleri için sayfa 587'ye bakınız.
Please see on page 587 for optional flange dimensions
Siehe Seite 587 für auswählbare Flanschabmessungen

	c1	c2	s1	m	m1	m2	i	u	k	d1	t1	e1	x
63/B5	3.5	5	9	115	140	95	240.5	12	311.5	11	4	12.8	-
71/B5	4	8.5	11	130	160	110	211.5	12	282.5	14	5	16.3	-
71/B14	3	8.5	7	85	105	70	211.5	10	282.5	14	5	16.3	-
80/B5	4	5	12	165	200	130	240.5	12	311.5	19	6	21.8	-
80/B14	4	5	7	100	120	80	240.5	12	311.5	19	6	21.8	-
90/B5	4	5	12	165	200	130	240.5	12	311.5	24	8	27.3	-
90//B14	4	5	9	115	140	95	240.5	12	311.5	24	8	27.3	-
100/B5	4.5	5.5	15	215	250	180	233.5	12	304.5	28	8	31.3	20.5
100/B14	4	5.5	9	130	160	110	233.5	12	304.5	28	8	31.3	-
112/B5	4.5	5.5	15	215	250	180	233.5	12	304.5	28	8	31.3	20.5
112/B14	4	5.5	9	130	160	110	233.5	12	304.5	28	8	31.3	-

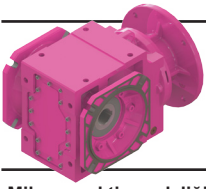

Ölçü Sayfaları Dimension Pages Abmessungsseiten

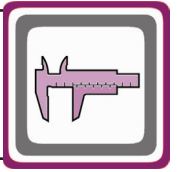

-Mil ucu çektirme deliği DIN 332 sayfa 2 / Tapped center hole to DIN 332, sheet 2 / Zentrierung mit Gewinde DIN 332, Blatt 2

KN273.08

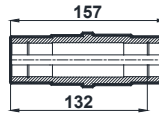
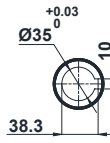
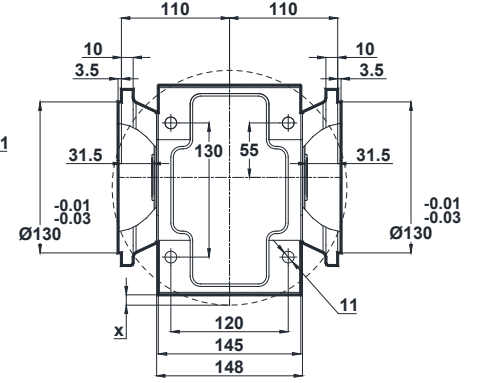
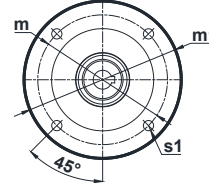
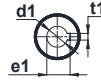
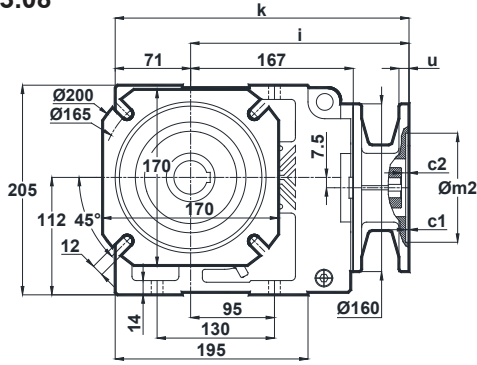

x: Motor Ayak bağlantı yüzeyinin altında ise
x: If Motor is lower than foot mounting plane
x: Wenn der Motor unter der Fußmontageebene ist

Opsiyonel flanş ölçüleri için sayfa 587'ye bakınız.
Please see on page 587 for optional flange dimensions
Siehe Seite 587 für auswählbare Flanschabmessungen

	c1	c2	s1	m	m1	m2	i	u	k	d1	t1	e1	x
63/B5	3.5	5	9	115	140	95	240.5	12	311.5	11	4	12.8	-
71/B5	4	8.5	11	130	160	110	211.5	12	282.5	14	5	16.3	-
71/B14	3		7	85	105	70		10					
80/B5	4	5	12	165	200	130	240.5	12	311.5	19	6	21.8	-
80/B14			7	100	120	80							
90/B5	4	5	12	165	200	130	240.5	12	311.5	24	8	27.3	-
90//B14			9	115	140	95							
100/B5	4.5	5.5	15	215	250	180	233.5	12	304.5	28	8	31.3	20.5
100/B14	4		9	130	160	110							-
112/B5	4.5	5.5	15	215	250	180	233.5	12	304.5	28	8	31.3	20.5
112/B14	4		9	130	160	110							-

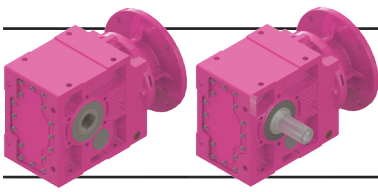

Ölçü Sayfaları

Dimension Pages

Abmessungsseiten

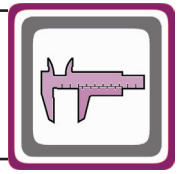

-Mil ucu çekirme deliği DIN 332 sayfa 2 / Tapped center hole to DIN 332, sheet 2 / Zentrierung mit Gewinde DIN 332, Blatt 2

KN275.00
KN276.00

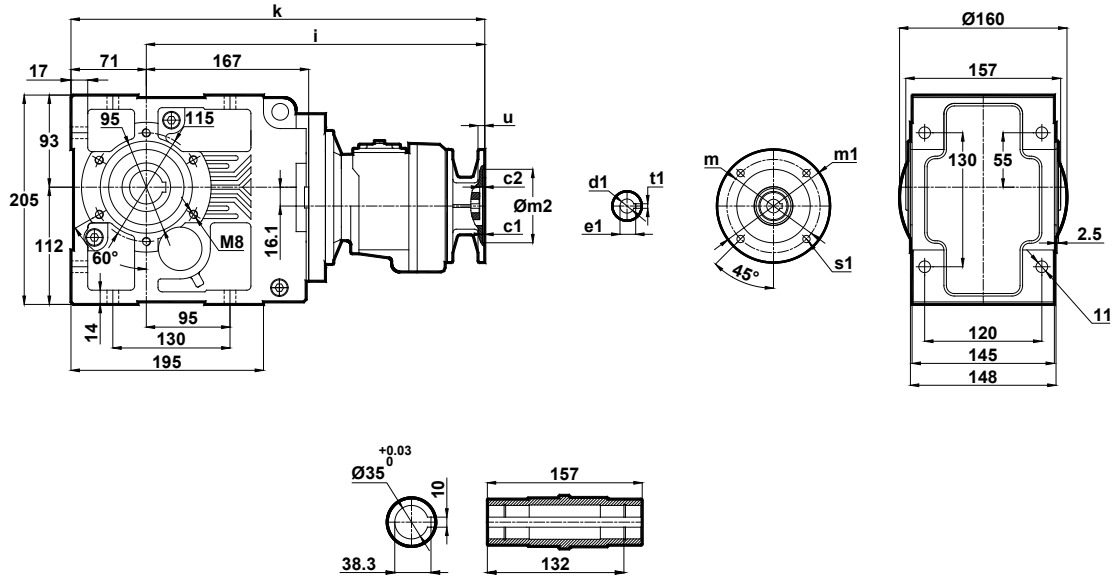

	c1	c2	s1	m	m1	m2	i	u	k	d1	t1	e1
63/B5	3.5	5	10	115	140	95	356	10	427	11	4	12.8
63/B14	2.5	5	5.5	75	90	60	356	10	427	11	4	12.8
71/B5	4	4.5	11	130	160	110	357.5	12	428.5	14	5	16.3
71/B14	3	4.5	7	85	105	70	357.5	10	428.5	14	5	16.3
80/B5	4	5	12	165	200	130	372.5	12	443.5	19	6	21.8
80/B14	4	5	7	100	120	80	372.5	12	443.5	19	6	21.8

KN275.01
KN276.01

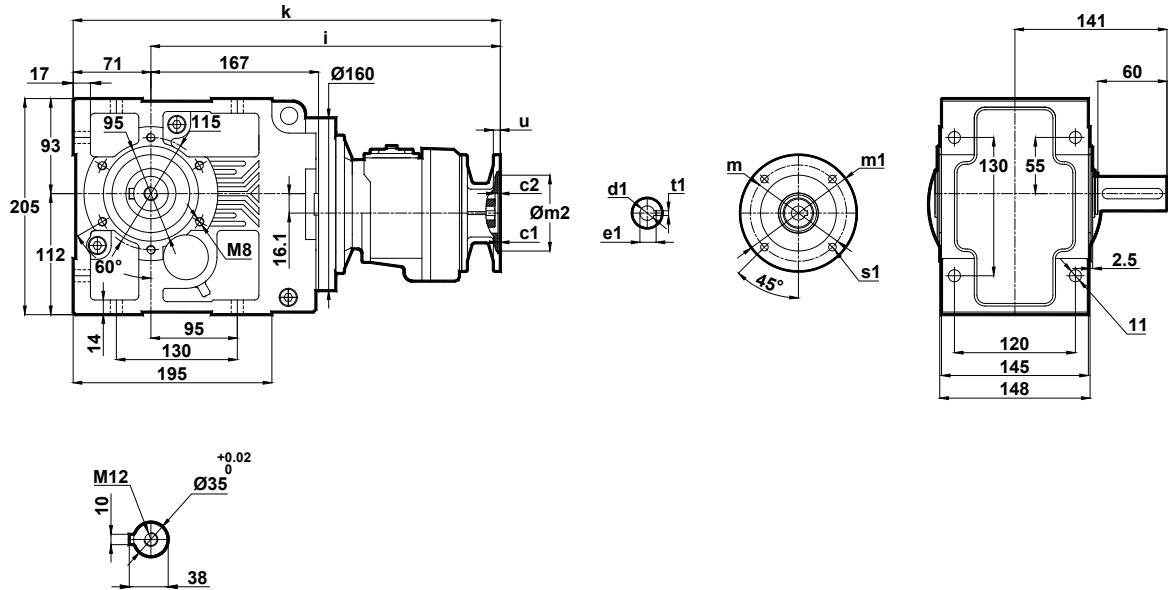

	c1	c2	s1	m	m1	m2	i	u	k	d1	t1	e1
63/B5	3.5	5	10	115	140	95	356	10	427	11	4	12.8
63/B14	2.5	5	5.5	75	90	60	356	10	427	11	4	12.8
71/B5	4	4.5	11	130	160	110	357.5	12	428.5	14	5	16.3
71/B14	3	4.5	7	85	105	70	357.5	10	428.5	14	5	16.3
80/B5	4	5	12	165	200	130	372.5	12	443.5	19	6	21.8
80/B14	4	5	7	100	120	80	372.5	12	443.5	19	6	21.8

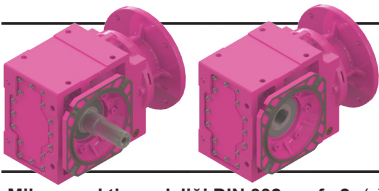

Ölçü Sayfaları

Dimension Pages

Abmessungsseiten

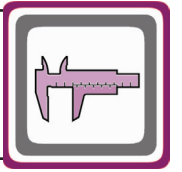

-Mil ucu çektirme deliği DIN 332 sayfa 2 / Tapped center hole to DIN 332, sheet 2 / Zentrierung mit Gewinde DIN 332, Blatt 2

KN275.02
KN276.02

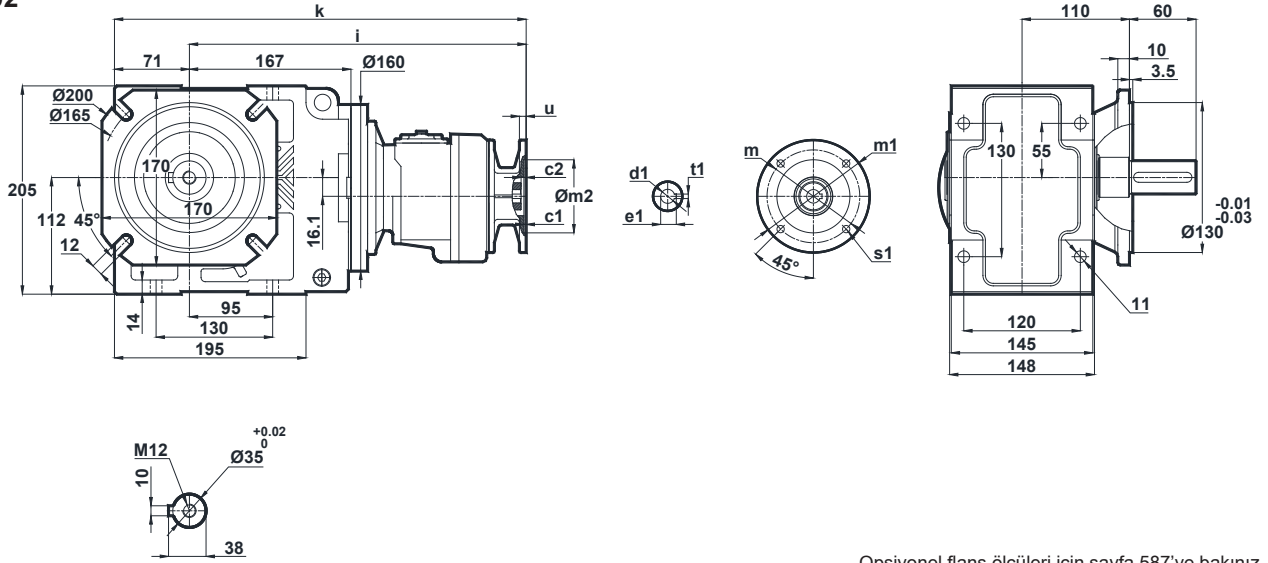

Opsiyonel flanş ölçüleri için sayfa 587'ye bakınız.
Please see on page 587 for optional flange dimensions
Siehe Seite 587 für auswählbare Flanschabmessungen

	c1	c2	s1	m	m1	m2	i	u	k	d1	t1	e1
63/B5	3.5	5	10	115	140	95	356	10	427	11	4	12.8
63/B14	2.5	5	5.5	75	90	60						
71/B5	4	4.5	11	130	160	110	357.5	12	428.5	14	5	16.3
71/B14	3	4.5	7	85	105	70		10				
80/B5	4	5	12	165	200	130	372.5	12	443.5	19	6	21.8
80/B14	4	5	7	100	120	80						

KN275.03
KN276.03

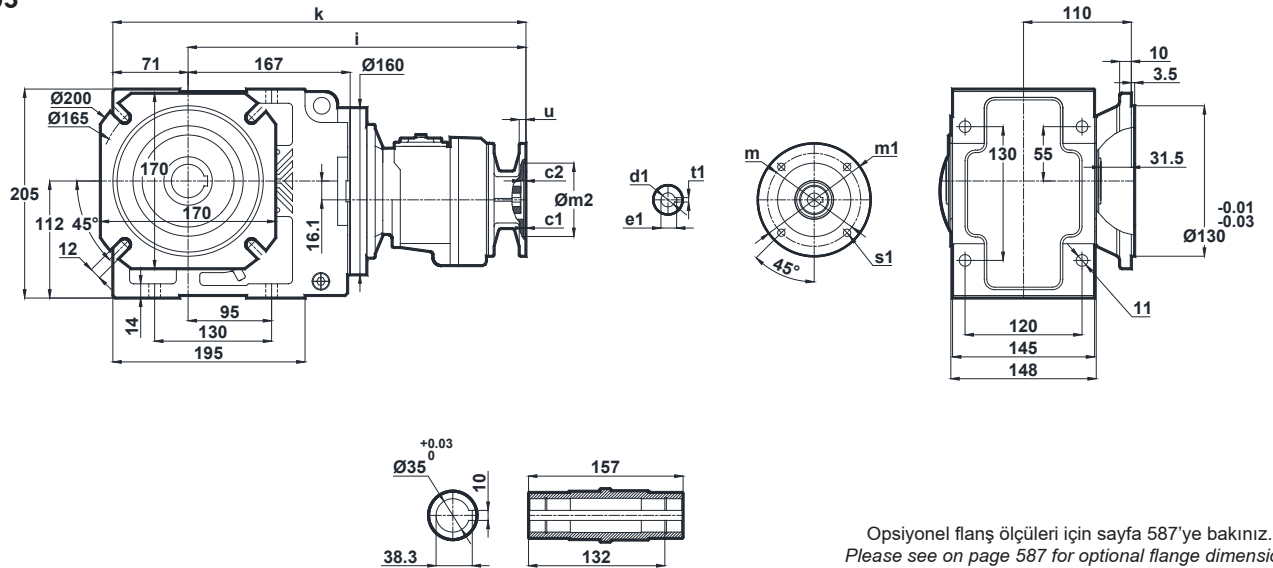

Opsiyonel flanş ölçüleri için sayfa 587'ye bakınız.
Please see on page 587 for optional flange dimensions
Siehe Seite 587 für auswählbare Flanschabmessungen

	c1	c2	s1	m	m1	m2	i	u	k	d1	t1	e1
63/B5	3.5	5	10	115	140	95	356	10	427	11	4	12.8
63/B14	2.5	5	5.5	75	90	60						
71/B5	4	4.5	11	130	160	110	357.5	12	428.5	14	5	16.3
71/B14	3	4.5	7	85	105	70		10				
80/B5	4	5	12	165	200	130	372.5	12	443.5	19	6	21.8
80/B14	4	5	7	100	120	80						

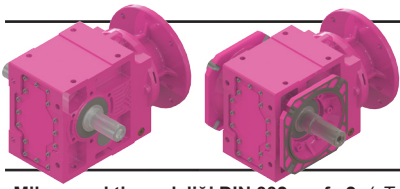

Ölçü Sayfaları Dimension Pages Abmessungsseiten

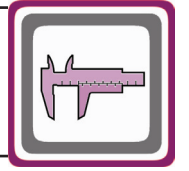

-Mil ucu çektirme deliği DIN 332 sayfa 2 / Tapped center hole to DIN 332, sheet 2 / Zentrierung mit Gewinde DIN 332, Blatt 2

KN275.04
KN276.04

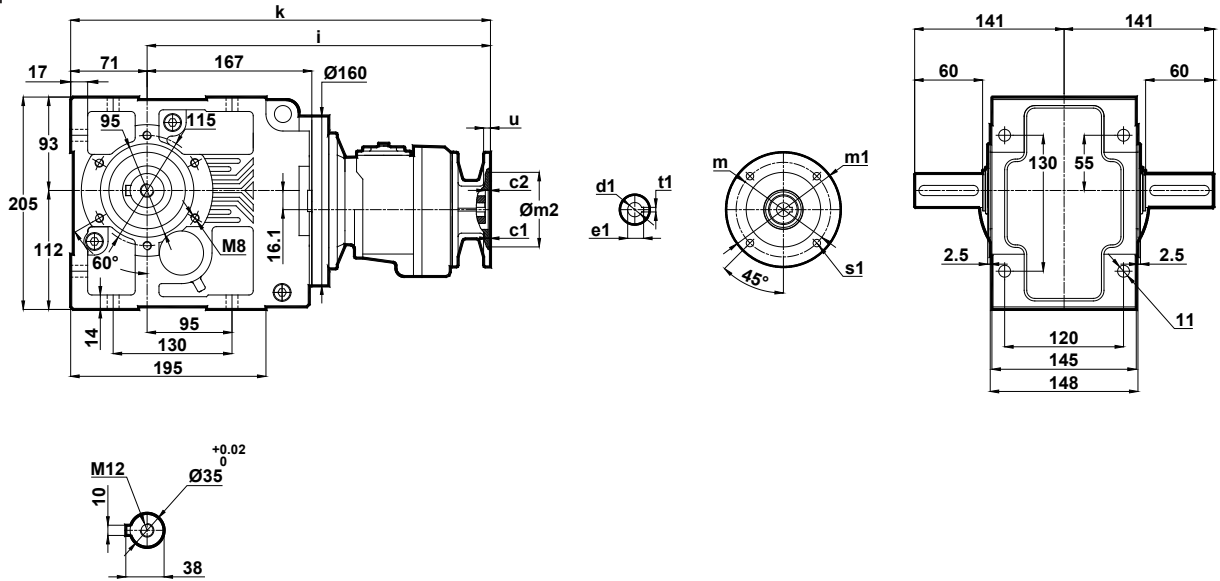

	c1	c2	s1	m	m1	m2	i	u	k	d1	t1	e1
63/B5	3.5	5	10	115	140	95	356	10	427	11	4	12.8
63/B14	2.5	5	5.5	75	90	60						
71/B5	4	4.5	11	130	160	110	357.5	12	428.5	14	5	16.3
71/B14	3	4.5	7	85	105	70		10				
80/B5	4	5	12	165	200	130	372.5	12	443.5	19	6	21.8
80/B14	4	5	7	100	120	80						

KN275.05
KN276.05

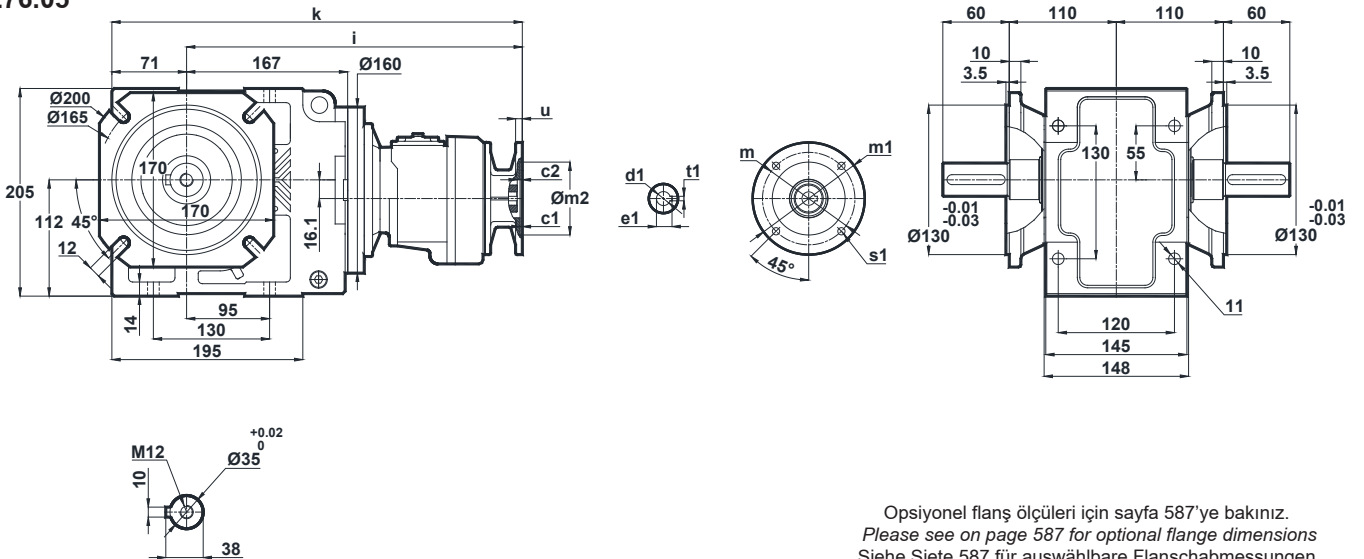

Opsiyonel flanş ölçüleri için sayfa 587'ye bakınız.
Please see on page 587 for optional flange dimensions
Siehe Seite 587 für auswählbare Flanschabmessungen

	c1	c2	s1	m	m1	m2	i	u	k	d1	t1	e1
63/B5	3.5	5	10	115	140	95	356	10	427	11	4	12.8
63/B14	2.5	5	5.5	75	90	60						
71/B5	4	4.5	11	130	160	110	357.5	12	428.5	14	5	16.3
71/B14	3	4.5	7	85	105	70		10				
80/B5	4	5	12	165	200	130	372.5	12	443.5	19	6	21.8
80/B14	4	5	7	100	120	80						

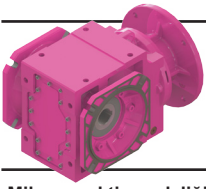

Ölçü Sayfaları

Dimension Pages

Abmessungsseiten

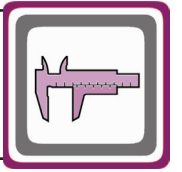

-Mil ucu çektirme deliği DIN 332 sayfa 2 / Tapped center hole to DIN 332, sheet 2 / Zentrierung mit Gewinde DIN 332, Blatt 2

KN275.08
KN276.08

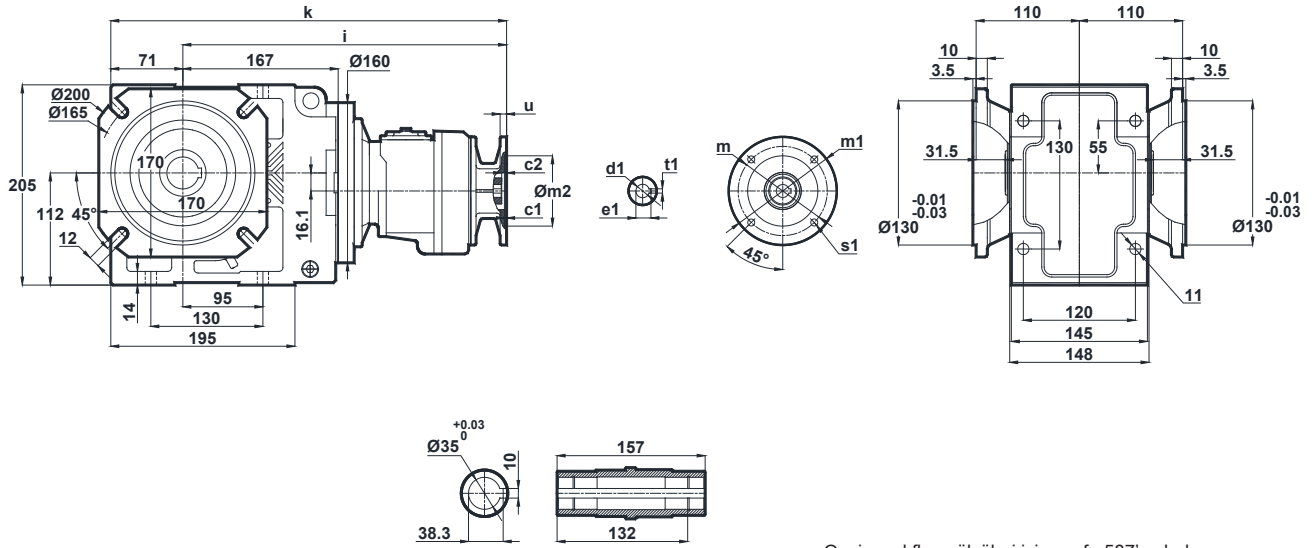

Opsiyonel flanş ölçüleri için sayfa 587'ye bakınız.
Please see on page 587 for optional flange dimensions
Siehe Seite 587 für auswählbare Flanschabmessungen

	c1	c2	s1	m	m1	m2	i	u	k	d1	t1	e1
63/B5	3.5	5	10	115	140	95	356	10	427	11	4	12.8
63/B14	2.5	5	5.5	75	90	60						
71/B5	4	4.5	11	130	160	110	357.5	12	428.5	14	5	16.3
71/B14	3	4.5	7	85	105	70		10				
80/B5	4	5	12	165	200	130	372.5	12	443.5	19	6	21.8
80/B14	4	5	7	100	120	80						

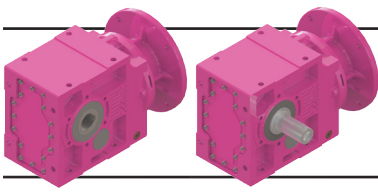

Ölçü Sayfaları

Dimension Pages

Abmessungsseiten

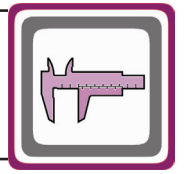

-Mil ucu çekirme deliği DIN 332 sayfa 2 / Tapped center hole to DIN 332, sheet 2 / Zentrierung mit Gewinde DIN 332, Blatt 2

KN283.00

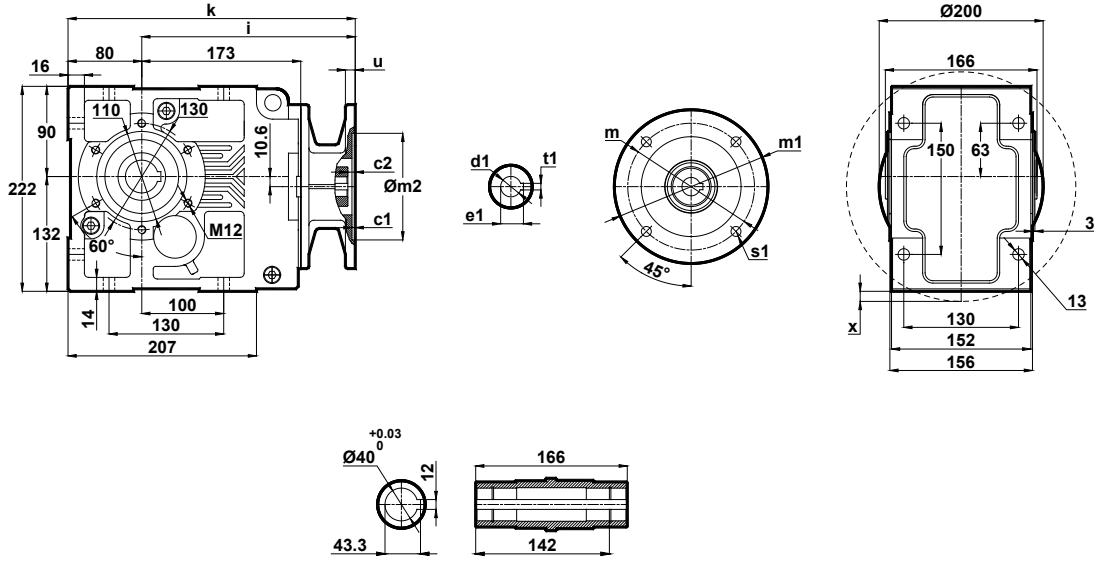

	c1	c2	s1	m	m1	m2	i	u	k	d1	t1	e1	x
71/B5	4	9	11	130	160	110	239.5	12	319.5	14	5	16.3	-
80/B5	4	9	12	165	200	130	239.5	12	319.5	19	6	21.8	-
80/B14	4	9	7	100	120	80	239.5	12	319.5	19	6	21.8	-
90/B5	4	9	12	165	200	130	239.5	12	319.5	24	8	27.3	-
90/B14	4	9	9	115	140	95	239.5	12	319.5	24	8	27.3	-
100/B5	4.5	9	15	215	250	180	256.5	15	336.5	28	8	31.3	3.6
100/B14	4	9	9	130	160	110	256.5	15	336.5	28	8	31.3	-
112/B5	4.5	9	15	215	250	180	256.5	15	336.5	28	8	31.3	3.6
112/B14	4	9	9	130	160	110	256.5	15	336.5	28	8	31.3	-
132/B5	4.5	7	15	265	300	230	276.5	15	356.5	38	10	41.3	28.6
132/B14	4.5	7	11	165	200	130	276.5	15	356.5	38	10	41.3	-

KN283.01

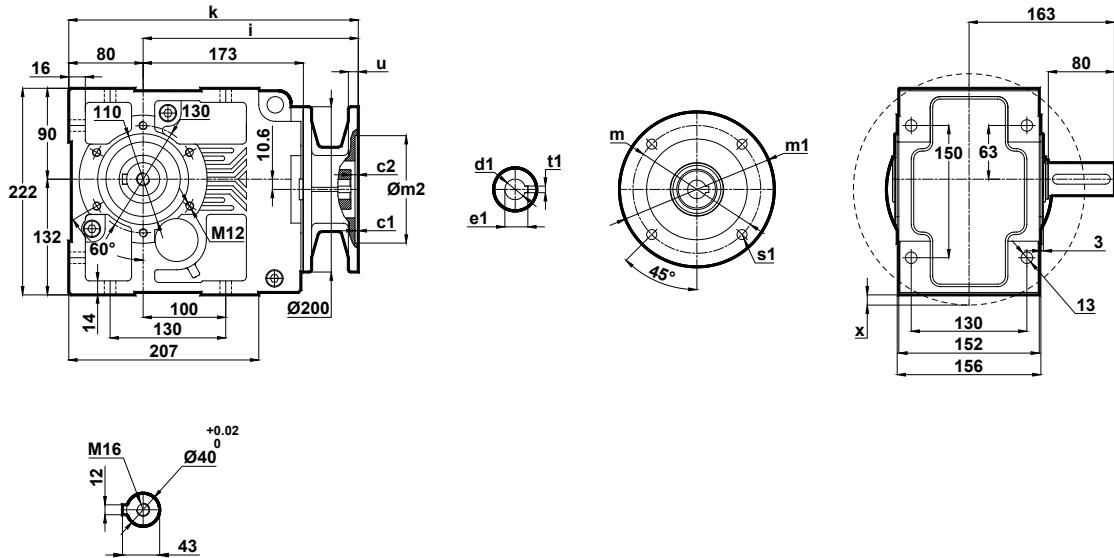

	c1	c2	s1	m	m1	m2	i	u	k	d1	t1	e1	x
71/B5	4	9	11	130	160	110	239.5	12	319.5	14	5	16.3	-
80/B5	4	9	12	165	200	130	239.5	12	319.5	19	6	21.8	-
80/B14	4	9	7	100	120	80	239.5	12	319.5	19	6	21.8	-
90/B5	4	9	12	165	200	130	239.5	12	319.5	24	8	27.3	-
90/B14	4	9	9	115	140	95	239.5	12	319.5	24	8	27.3	-
100/B5	4.5	9	15	215	250	180	256.5	15	336.5	28	8	31.3	3.6
100/B14	4	9	9	130	160	110	256.5	15	336.5	28	8	31.3	-
112/B5	4.5	9	15	215	250	180	256.5	15	336.5	28	8	31.3	3.6
112/B14	4	9	9	130	160	110	256.5	15	336.5	28	8	31.3	-
132/B5	4.5	7	15	265	300	230	276.5	15	356.5	38	10	41.3	28.6
132/B14	4.5	7	11	165	200	130	276.5	15	356.5	38	10	41.3	-

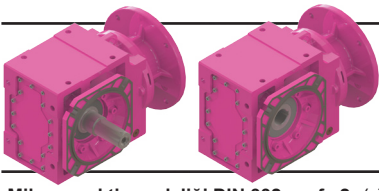

Ölçü Sayfaları

Dimension Pages

Abmessungsseiten

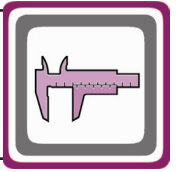

-Mil ucu çektirme deliği DIN 332 sayfa 2 / Tapped center hole to DIN 332, sheet 2 / Zentrierung mit Gewinde DIN 332, Blatt 2

KN283.02

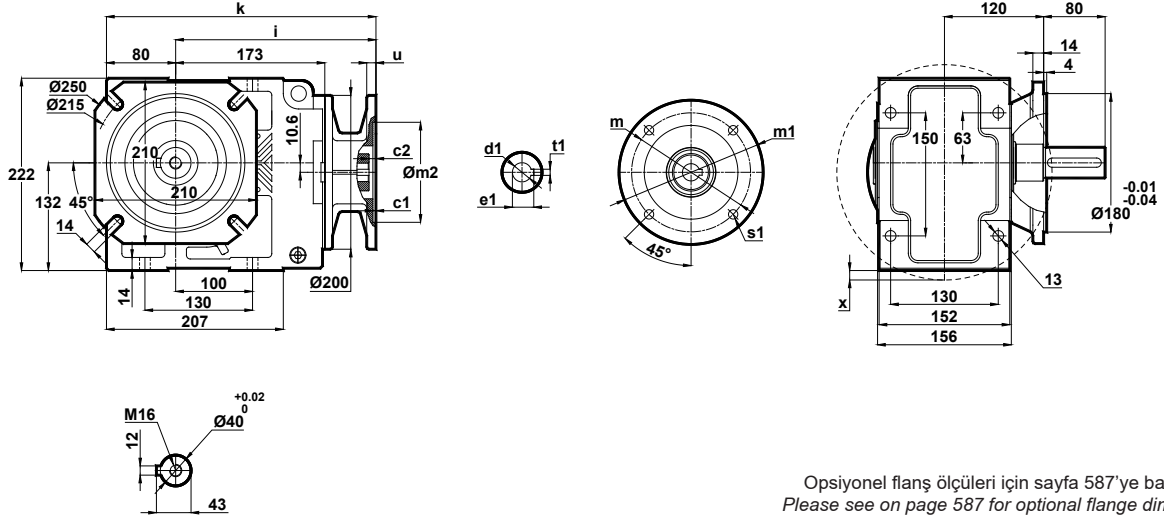

Opsiyonel flanş ölçüleri için sayfa 587'ye bakınız.
Please see on page 587 for optional flange dimensions
Siehe Seite 587 für auswählbare Flanschabmessungen

	c1	c2	s1	m	m1	m2	i	u	k	d1	t1	e1	x
71/B5	4	9	11	130	160	110	239.5	12	319.5	14	5	16.3	-
80/B5	4	9	12	165	200	130	239.5	12	319.5	19	6	21.8	-
80/B14	4	9	7	100	120	80	239.5	12	319.5	19	6	21.8	-
90/B5	4	9	12	165	200	130	239.5	12	319.5	24	8	27.3	-
90/B14	4	9	9	115	140	95	239.5	12	319.5	24	8	27.3	-
100/B5	4.5	9	15	215	250	180	256.5	15	336.5	28	8	31.3	3.6
100/B14	4	9	9	130	160	110	256.5	15	336.5	28	8	31.3	-
112/B5	4.5	9	15	215	250	180	256.5	15	336.5	28	8	31.3	3.6
112/B14	4	9	9	130	160	110	256.5	15	336.5	28	8	31.3	-
132/B5	4.5	7	15	265	300	230	276.5	15	356.5	38	10	41.3	28.6
132/B14	4.5	7	11	165	200	130	276.5	15	356.5	38	10	41.3	-

KN283.03

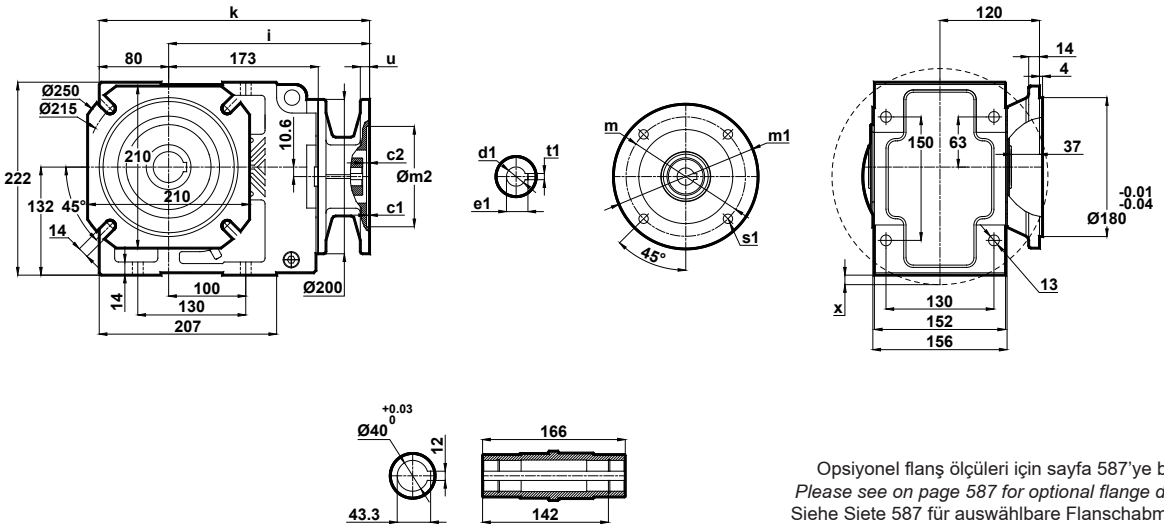

Opsiyonel flanş ölçüleri için sayfa 587'ye bakınız.
Please see on page 587 for optional flange dimensions
Siehe Seite 587 für auswählbare Flanschabmessungen

	c1	c2	s1	m	m1	m2	i	u	k	d1	t1	e1	x
71/B5	4	9	11	130	160	110	239.5	12	319.5	14	5	16.3	-
80/B5	4	9	12	165	200	130	239.5	12	319.5	19	6	21.8	-
80/B14	4	9	7	100	120	80	239.5	12	319.5	19	6	21.8	-
90/B5	4	9	12	165	200	130	239.5	12	319.5	24	8	27.3	-
90/B14	4	9	9	115	140	95	239.5	12	319.5	24	8	27.3	-
100/B5	4.5	9	15	215	250	180	256.5	15	336.5	28	8	31.3	3.6
100/B14	4	9	9	130	160	110	256.5	15	336.5	28	8	31.3	-
112/B5	4.5	9	15	215	250	180	256.5	15	336.5	28	8	31.3	3.6
112/B14	4	9	9	130	160	110	256.5	15	336.5	28	8	31.3	-
132/B5	4.5	7	15	265	300	230	276.5	15	356.5	38	10	41.3	28.6
132/B14	4.5	7	11	165	200	130	276.5	15	356.5	38	10	41.3	-

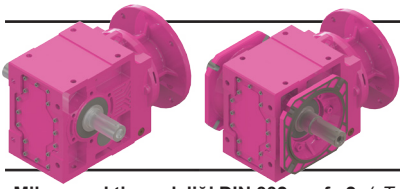

Ölçü Sayfaları Dimension Pages Abmessungsseiten

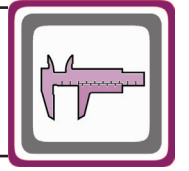

-Mil ucu çekirme deliği DIN 332 sayfa 2 / Tapped center hole to DIN 332, sheet 2 / Zentrierung mit Gewinde DIN 332, Blatt 2

KN283.04

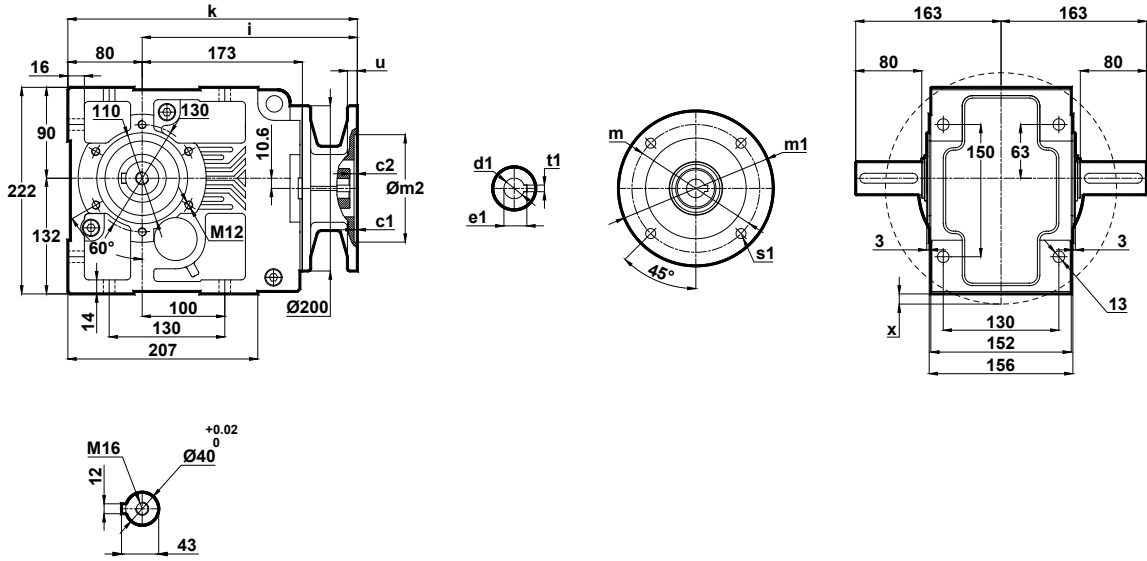

	c1	c2	s1	m	m1	m2	i	u	k	d1	t1	e1	x
71/B5	4	9	11	130	160	110	239.5	12	319.5	14	5	16.3	-
80/B5 80/B14	4	9	7	100	120	80	239.5	12	319.5	19	6	21.8	-
90/B5 90/B14	4	9	9	115	140	95	239.5	12	319.5	24	8	27.3	-
100/B5 100/B14	4.5 4	9	9	130	160	110	256.5	15	336.5	28	8	31.3	3.6 -
112/B5 112/B14	4.5 4	9	9	130	160	110	256.5	15	336.5	28	8	31.3	3.6 -
132/B5 132/B14	4.5	7	11	165	200	130	276.5	15	356.5	38	10	41.3	28.6 -

KN283.05

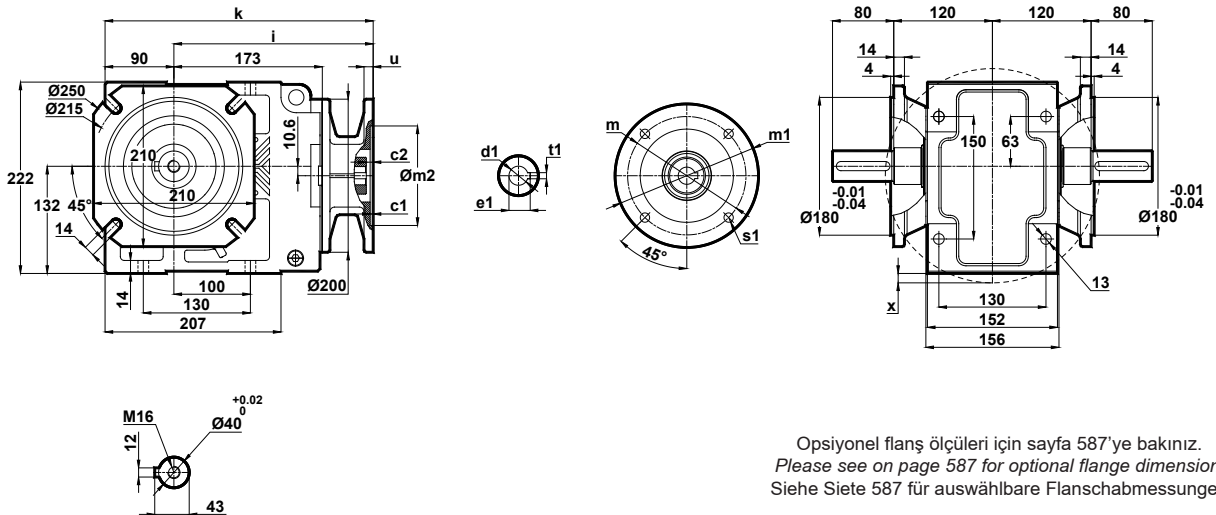

Opsiyonel flanş ölçüleri için sayfa 587'ye bakınız.
Please see on page 587 for optional flange dimensions
Siehe Seite 587 für auswählbare Flanschabmessungen

	c1	c2	s1	m	m1	m2	i	u	k	d1	t1	e1	x
71/B5	4	9	11	130	160	110	239.5	12	319.5	14	5	16.3	-
80/B5 80/B14	4	9	7	100	120	80	239.5	12	319.5	19	6	21.8	-
90/B5 90/B14	4	9	9	115	140	95	239.5	12	319.5	24	8	27.3	-
100/B5 100/B14	4.5 4	9	9	130	160	110	256.5	15	336.5	28	8	31.3	3.6 -
112/B5 112/B14	4.5 4	9	9	130	160	110	256.5	15	336.5	28	8	31.3	3.6 -
132/B5 132/B14	4.5	7	11	165	200	130	276.5	15	356.5	38	10	41.3	28.6 -

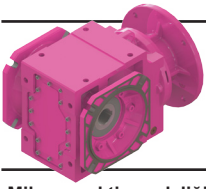

Ölçü Sayfaları

Dimension Pages

Abmessungsseiten

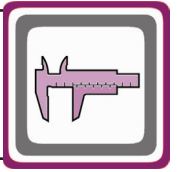

-Mil ucu çektirme deliği DIN 332 sayfa 2 / Tapped center hole to DIN 332, sheet 2 / Zentrierung mit Gewinde DIN 332, Blatt 2

KN283.08

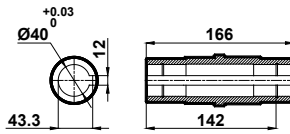
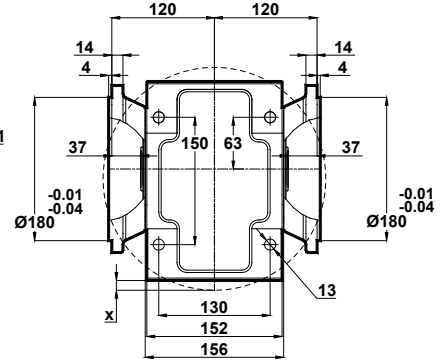
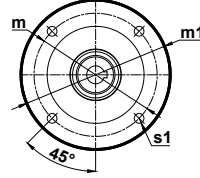
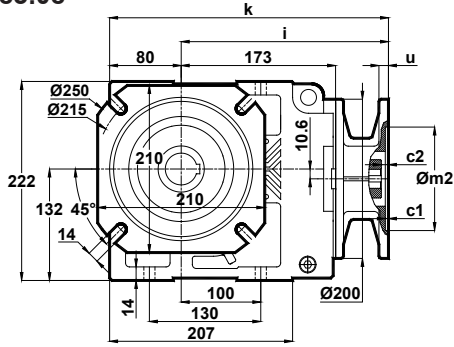

Opsiyonel flanş ölçüleri için sayfa 587'ye bakınız.
Please see on page 587 for optional flange dimensions
Siehe Seite 587 für auswählbare Flanschabmessungen

	c1	c2	s1	m	m1	m2	i	u	k	d1	t1	e1	x
71/B5	4	9	11	130	160	110	239.5	12	319.5	14	5	16.3	-
80/B5	4	9	12	165	200	130	239.5	12	319.5	19	6	21.8	-
80/B14	4	9	7	100	120	80	239.5	12	319.5	19	6	21.8	-
90/B5	4	9	12	165	200	130	239.5	12	319.5	24	8	27.3	-
90/B14	4	9	9	115	140	95	239.5	12	319.5	24	8	27.3	-
100/B5	4.5	9	15	215	250	180	256.5	15	336.5	28	8	31.3	3.6
100/B14	4	9	9	130	160	110	256.5	15	336.5	28	8	31.3	-
112/B5	4.5	9	15	215	250	180	256.5	15	336.5	28	8	31.3	3.6
112/B14	4	9	9	130	160	110	256.5	15	336.5	28	8	31.3	-
132/B5	4.5	7	15	265	300	230	276.5	15	356.5	38	10	41.3	28.6
132/B14	4.5	7	11	165	200	130	276.5	15	356.5	38	10	41.3	-

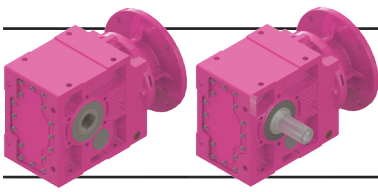

Ölçü Sayfaları

Dimension Pages

Abmessungsseiten

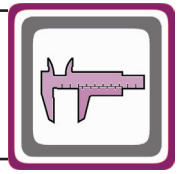

-Mil ucu çekirme deliği DIN 332 sayfa 2 / Tapped center hole to DIN 332, sheet 2 / Zentrierung mit Gewinde DIN 332, Blatt 2

KN284.00

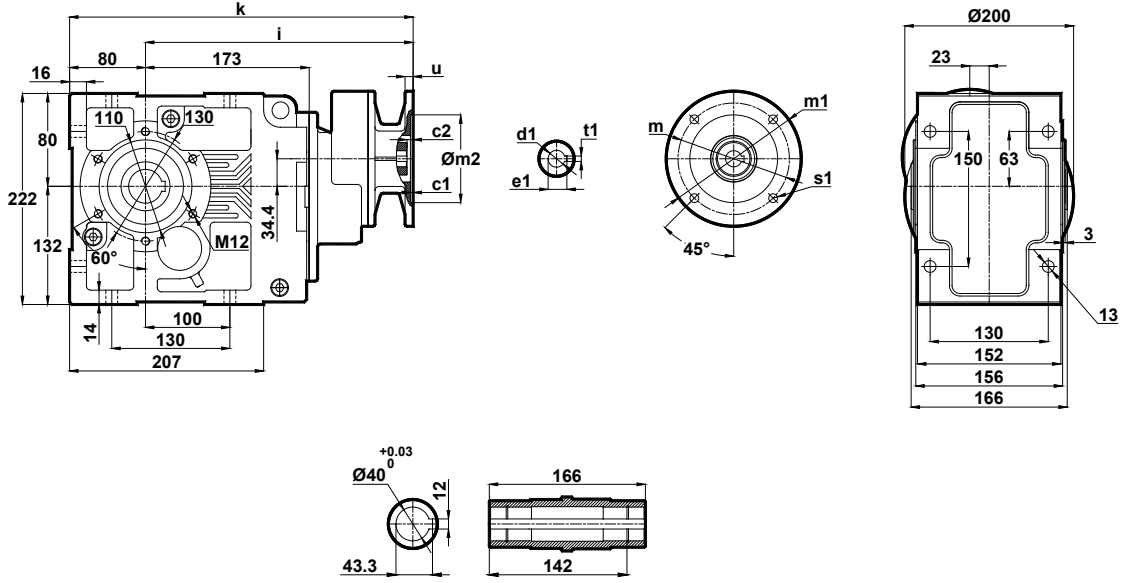

	c1	c2	s1	m	m1	m2	i	u	k	d1	t1	e1
63/B5	3.5	5	9	115	140	95	316.5	12	396.5	11	4	12.8
71/B5	4	8.5	11	130	160	110	287.5	12	367.5	14	5	16.3
71/B14	3		7	85	105	70		10				
80/B5	4	5	12	165	200	130	316.5	12	396.5	19	6	21.8
80/B14			7	100	120	80						

KN284.01

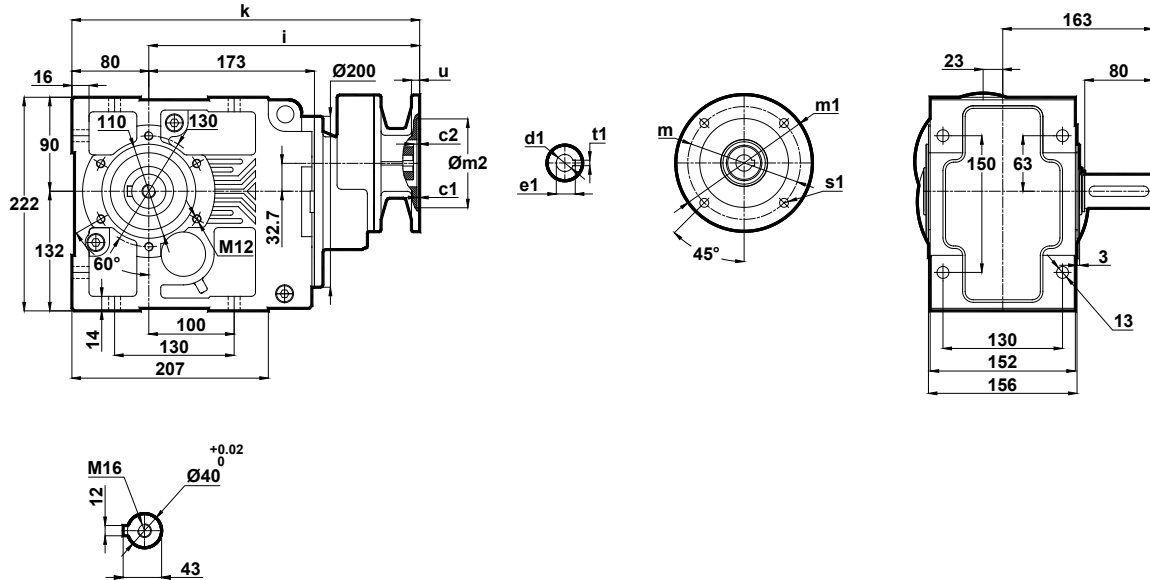

	c1	c2	s1	m	m1	m2	i	u	k	d1	t1	e1
63/B5	3.5	5	9	115	140	95	316.5	12	396.5	11	4	12.8
71/B5	4	8.5	11	130	160	110	287.5	12	367.5	14	5	16.3
71/B14	3		7	85	105	70		10				
80/B5	4	5	12	165	200	130	316.5	12	396.5	19	6	21.8
80/B14			7	100	120	80						

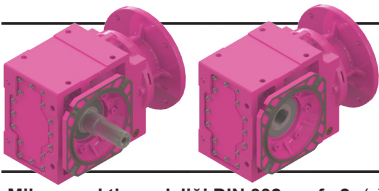

Ölçü Sayfaları Dimension Pages Abmessungsseiten

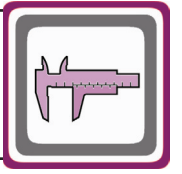

-Mil ucu çektirme deliği DIN 332 sayfa 2 / Tapped center hole to DIN 332, sheet 2 / Zentrierung mit Gewinde DIN 332, Blatt 2

KN284.02

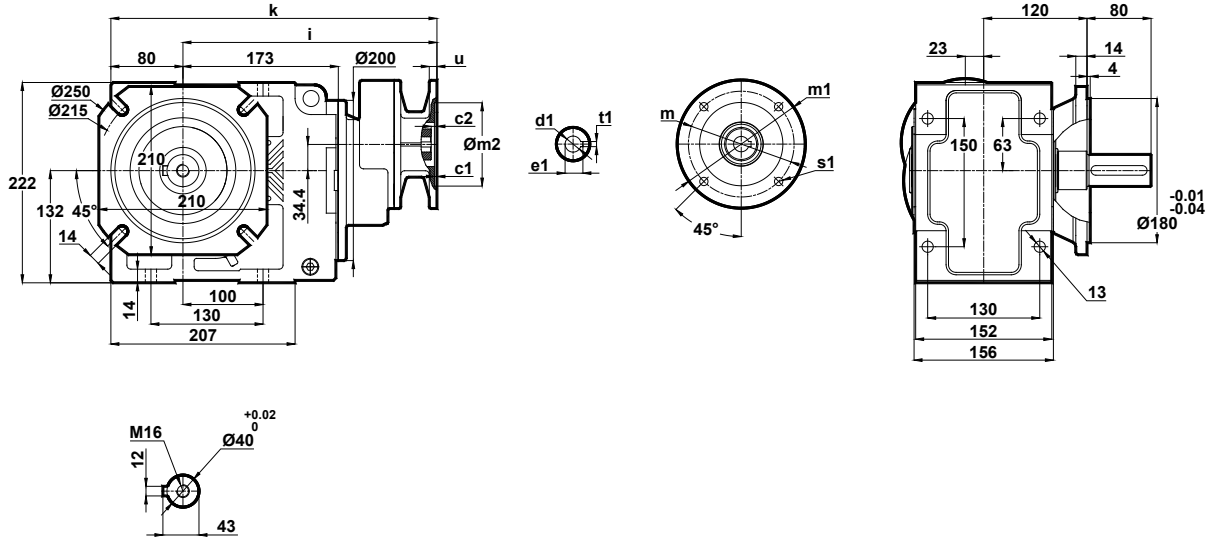

Opsiyonel flanş ölçüleri için sayfa 587'ye bakınız.
Please see on page 587 for optional flange dimensions
Siehe Seite 587 für auswählbare Flanschabmessungen

	c1	c2	s1	m	m1	m2	i	u	k	d1	t1	e1
63/B5	3.5	5	9	115	140	95	316.5	12	396.5	11	4	12.8
71/B5	4	8.5	11	130	160	110	287.5	12	367.5	14	5	16.3
71/B14	3		7	85	105	70		10				
80/B5	4	5	12	165	200	130	316.5	12	396.5	19	6	21.8
80/B14			7	100	120	80						

KN284.03

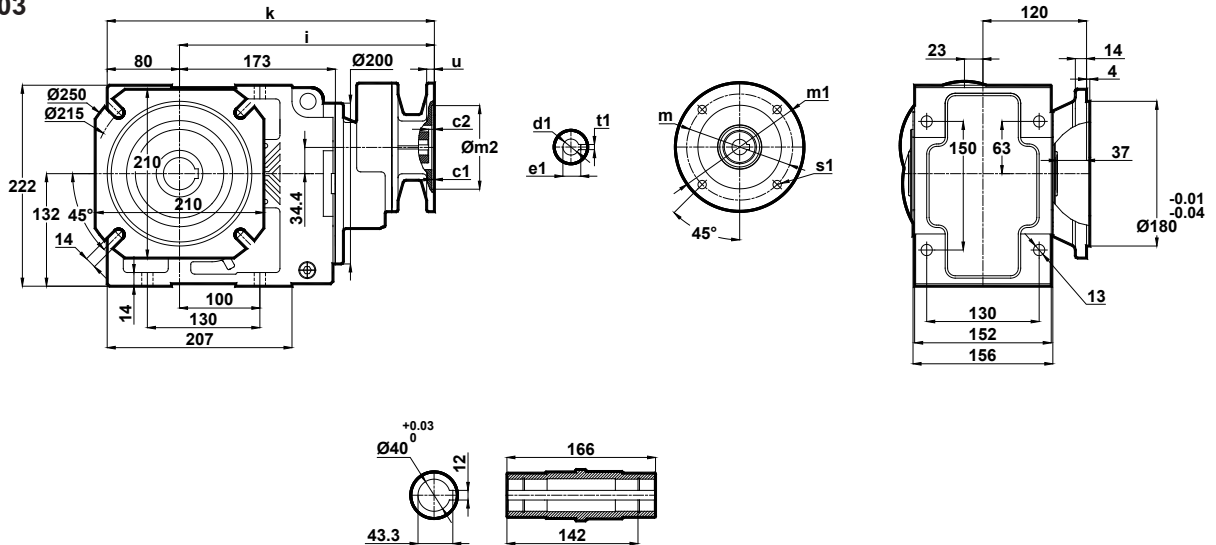

Opsiyonel flanş ölçüleri için sayfa 587'ye bakınız.
Please see on page 587 for optional flange dimensions
Siehe Seite 587 für auswählbare Flanschabmessungen

	c1	c2	s1	m	m1	m2	i	u	k	d1	t1	e1
63/B5	3.5	5	9	115	140	95	316.5	12	396.5	11	4	12.8
71/B5	4	8.5	11	130	160	110	287.5	12	367.5	14	5	16.3
71/B14	3		7	85	105	70		10				
80/B5	4	5	12	165	200	130	316.5	12	396.5	19	6	21.8
80/B14			7	100	120	80						

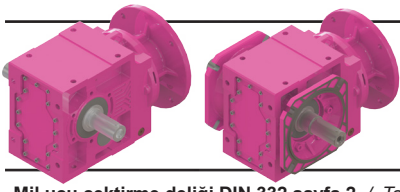

Ölçü Sayfaları Dimension Pages Abmessungsseiten

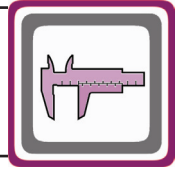

-Mil ucu çekirme deliği DIN 332 sayfa 2 / Tapped center hole to DIN 332, sheet 2 / Zentrierung mit Gewinde DIN 332, Blatt 2

KN284.04

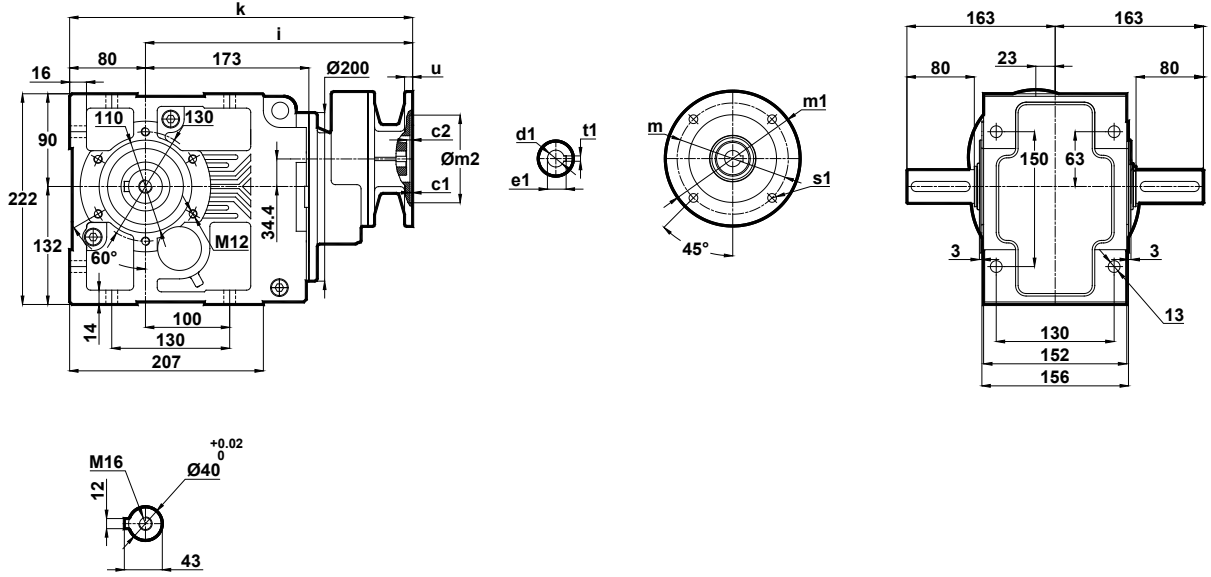

	c1	c2	s1	m	m1	m2	i	u	k	d1	t1	e1
63/B5	3.5	5	9	115	140	95	316.5	12	396.5	11	4	12.8
71/B5	4	8.5	11	130	160	110	287.5	12	367.5	14	5	16.3
71/B14	3		7	85	105	70		10				
80/B5	4	5	12	165	200	130	316.5	12	396.5	19	6	21.8
80/B14			7	100	120	80						

KN284.05

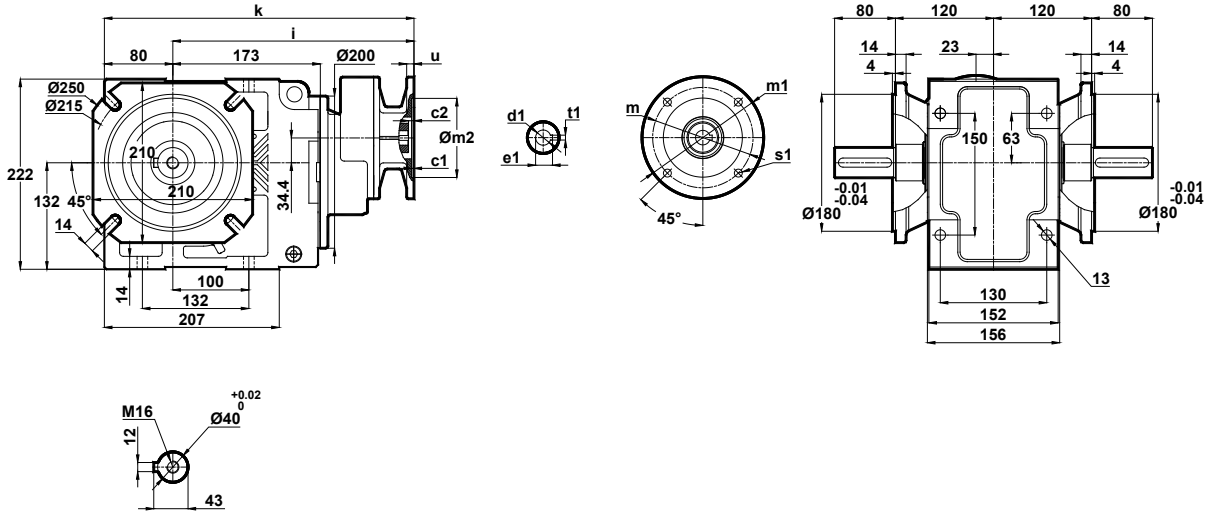

Opsiyonel flanş ölçüleri için sayfa 587'ye bakınız.
Please see on page 587 for optional flange dimensions
Siehe Seite 587 für auswählbare Flanschabmessungen

	c1	c2	s1	m	m1	m2	i	u	k	d1	t1	e1
63/B5	3.5	5	9	115	140	95	316.5	12	396.5	11	4	12.8
71/B5	4	8.5	11	130	160	110	287.5	12	367.5	14	5	16.3
71/B14	3		7	85	105	70		10				
80/B5	4	5	12	165	200	130	316.5	12	396.5	19	6	21.8
80/B14			7	100	120	80						

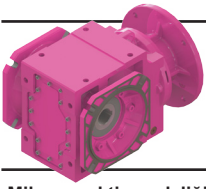

Ölçü Sayfaları Dimension Pages Abmessungsseiten

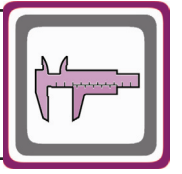

-Mil ucu çektirme deliği DIN 332 sayfa 2 / Tapped center hole to DIN 332, sheet 2 / Zentrierung mit Gewinde DIN 332, Blatt 2

KN284.08

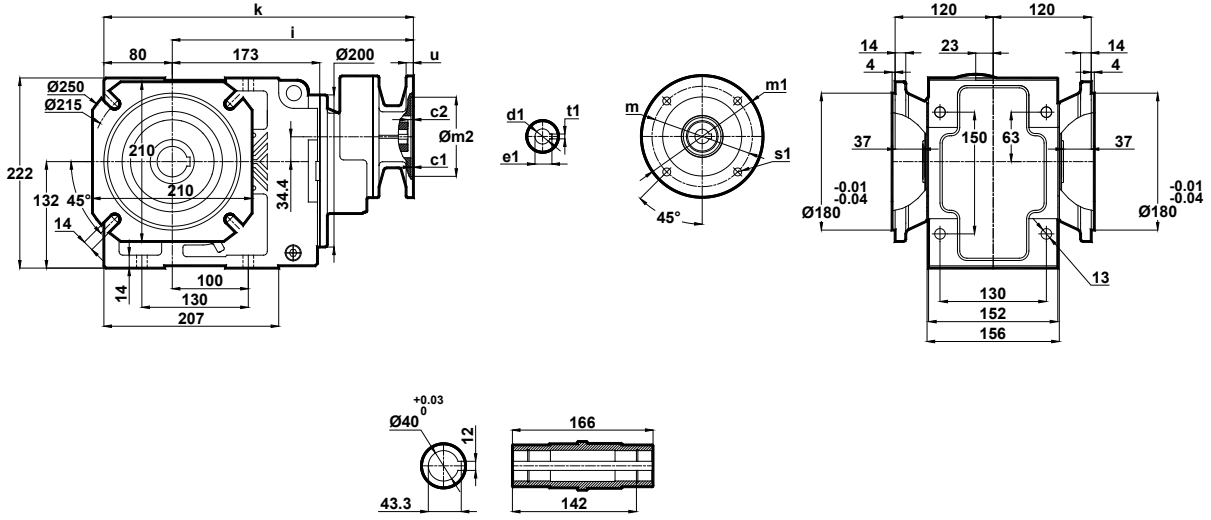

Opsiyonel flanş ölçüleri için sayfa 587'ye bakınız.
Please see on page 587 for optional flange dimensions
Siehe Seite 587 für auswählbare Flanschabmessungen

	c1	c2	s1	m	m1	m2	i	u	k	d1	t1	e1
63/B5	3.5	5	9	115	140	95	316.5	12	396.5	11	4	12.8
71/B5	4			130	160	110		12				
71/B14	3	8.5	7	85	105	70	287.5	10	367.5	14	5	16.3
80/B5	4			165	200	130		12				
80/B14		5	7	100	120	80	316.5		396.5	19	6	21.8

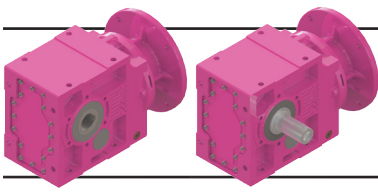

Ölçü Sayfaları

Dimension Pages

Abmessungsseiten

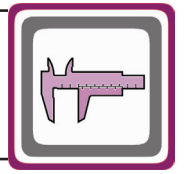

-Mil ucu çekirme deliği DIN 332 sayfa 2 / Tapped center hole to DIN 332, sheet 2 / Zentrierung mit Gewinde DIN 332, Blatt 2

KN285.00
KN286.00

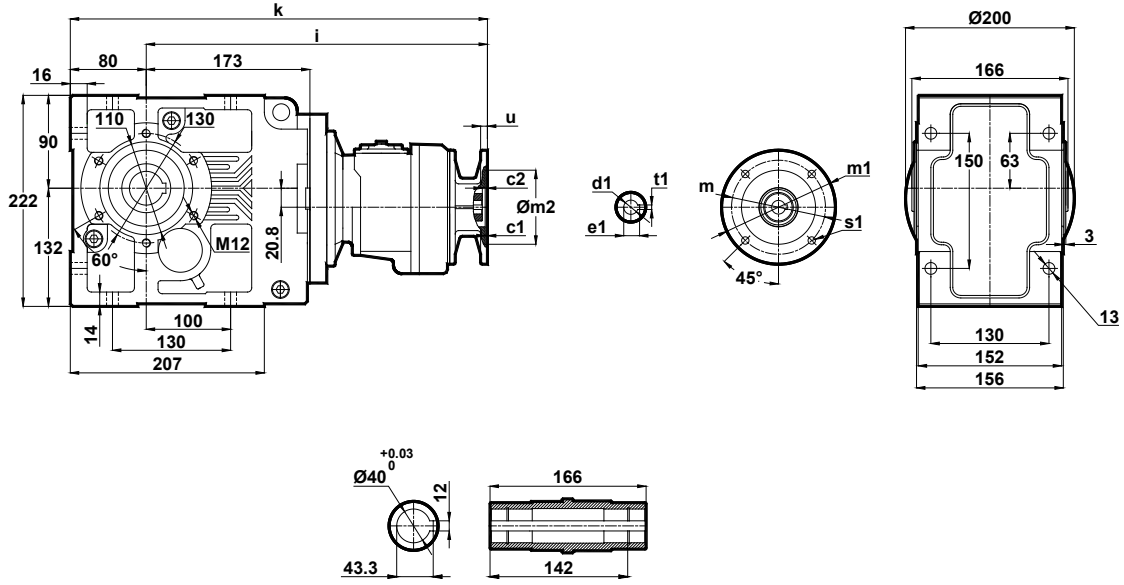

	c1	c2	s1	m	m1	m2	i	u	k	d1	t1	e1
63/B5	3.5	5	10	115	140	95	382	10	549	11	4	12.8

KN285.01
KN286.01

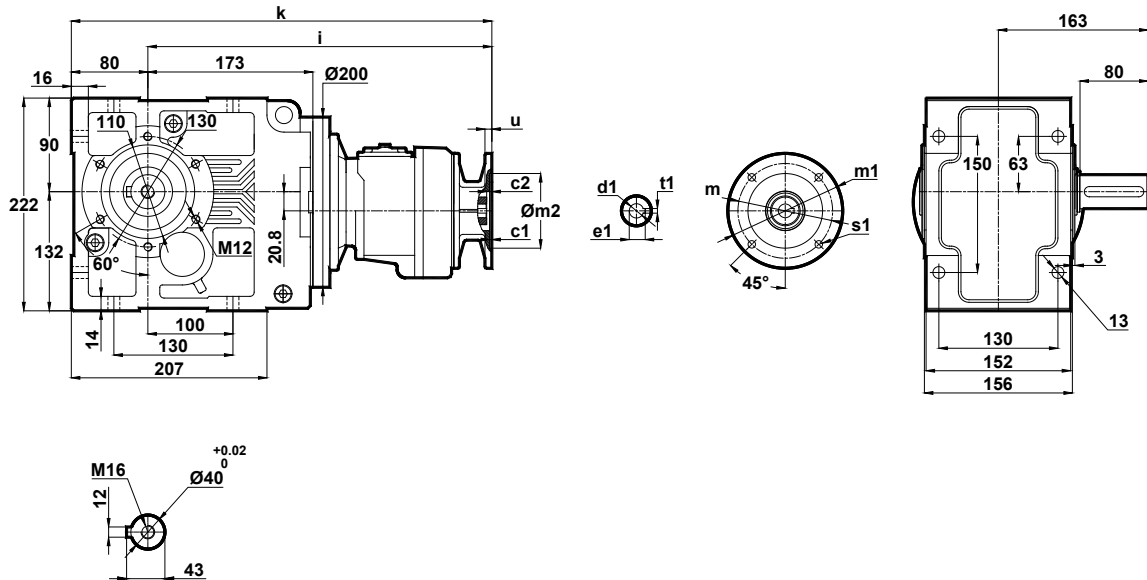

	c1	c2	s1	m	m1	m2	i	u	k	d1	t1	e1
63/B5	3.5	5	10	115	140	95	382	10	549	11	4	12.8

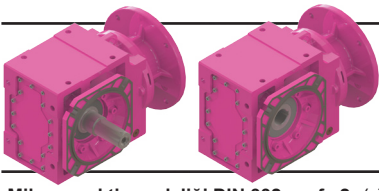

Ölçü Sayfaları

Dimension Pages

Abmessungsseiten

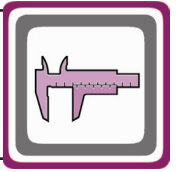

-Mil ucu çekirme deliği DIN 332 sayfa 2 / Tapped center hole to DIN 332, sheet 2 / Zentrierung mit Gewinde DIN 332, Blatt 2

KN285.02
KN286.02

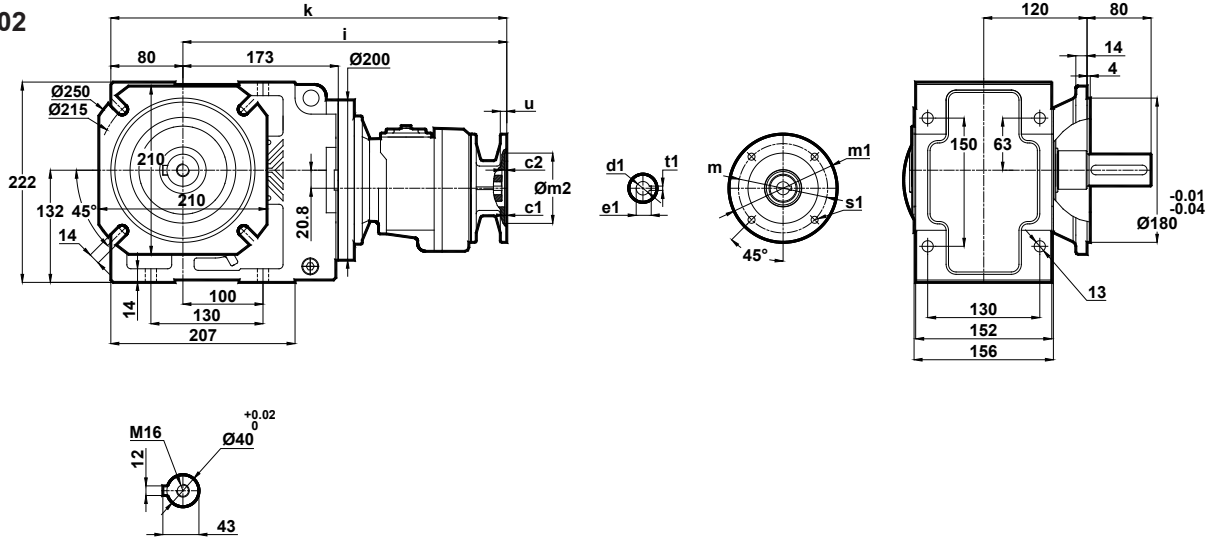

Opsiyonel flanş ölçüleri için sayfa 587'ye bakınız.
Please see on page 587 for optional flange dimensions
Siehe Seite 587 für auswählbare Flanschabmessungen

	c1	c2	s1	m	m1	m2	i	u	k	d1	t1	e1
63/B5	3.5	5	10	115	140	95	382	10	549	11	4	12.8

KN285.03
KN286.03

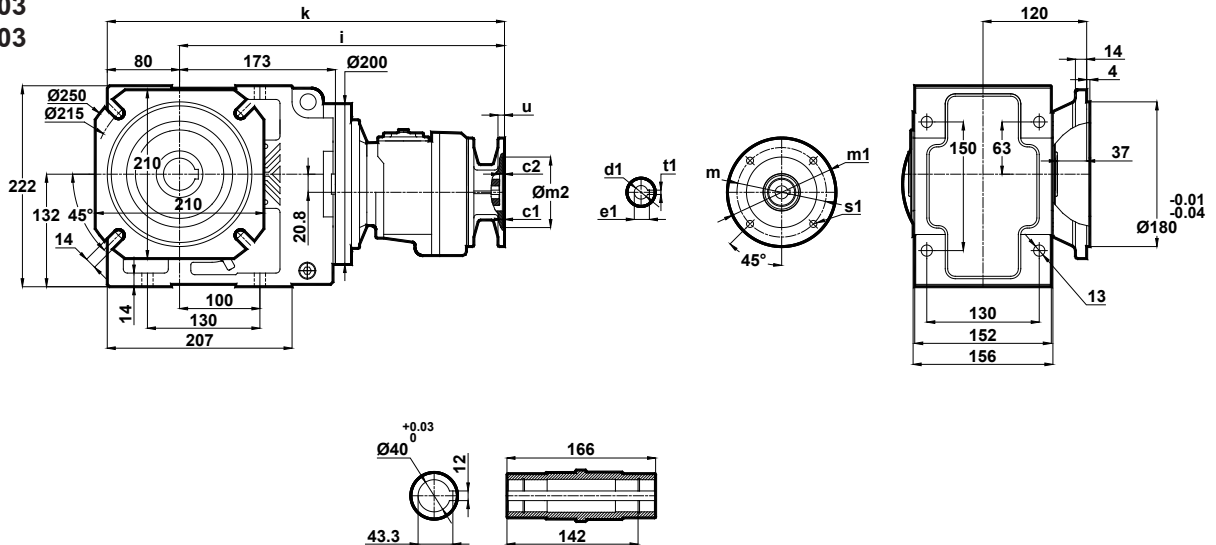

Opsiyonel flanş ölçüleri için sayfa 587'ye bakınız.
Please see on page 587 for optional flange dimensions
Siehe Seite 587 für auswählbare Flanschabmessungen

	c1	c2	s1	m	m1	m2	i	u	k	d1	t1	e1
63/B5	3.5	5	10	115	140	95	382	10	549	11	4	12.8

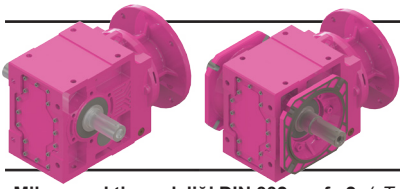

Ölçü Sayfaları

Dimension Pages

Abmessungsseiten

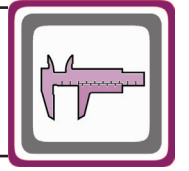

-Mil ucu çekirme deliği DIN 332 sayfa 2 / Tapped center hole to DIN 332, sheet 2 / Zentrierung mit Gewinde DIN 332, Blatt 2

KN285.04
KN286.04

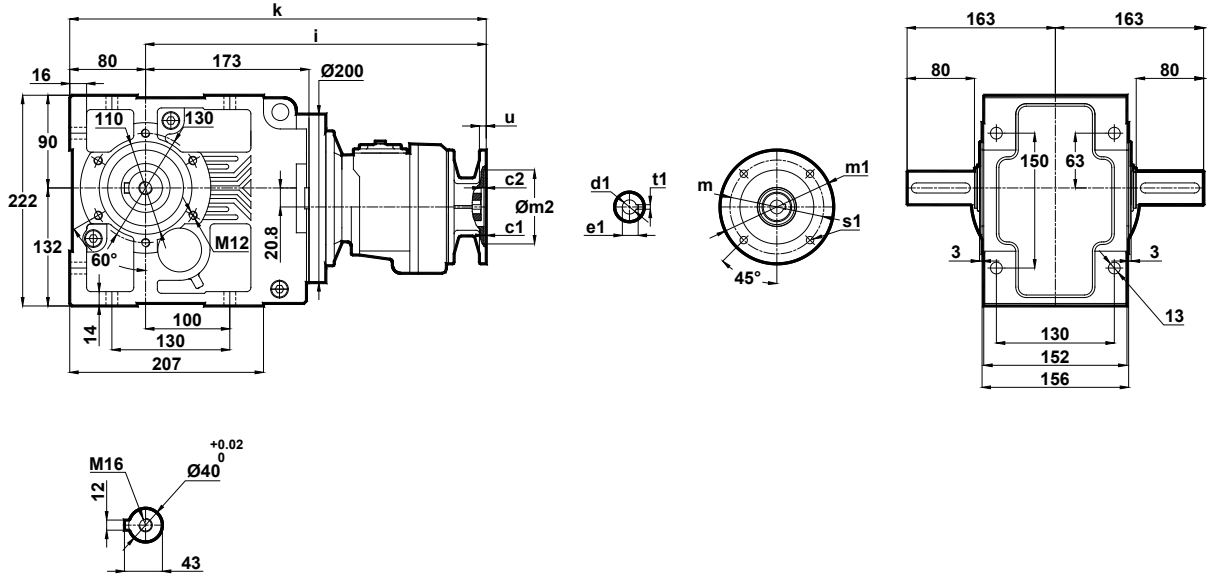

	c1	c2	s1	m	m1	m2	i	u	k	d1	t1	e1
63/B5	3.5	5	10	115	140	95	382	10	549	11	4	12.8

KN285.05
KN286.05

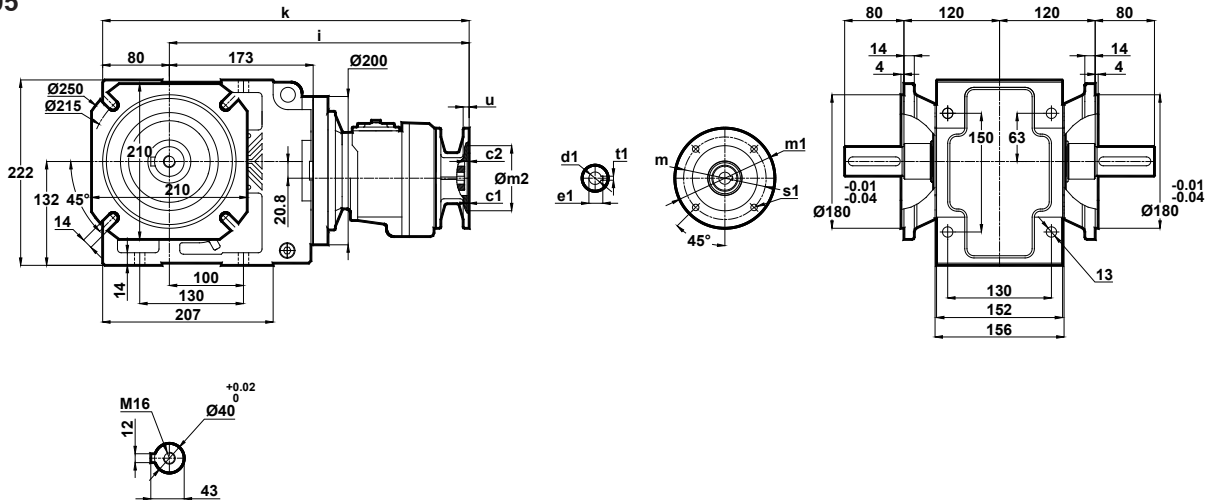

Opsiyonel flanş ölçüleri için sayfa 587'ye bakınız.
Please see on page 587 for optional flange dimensions
Siehe Seite 587 für auswählbare Flanschabmessungen

	c1	c2	s1	m	m1	m2	i	u	k	d1	t1	e1
63/B5	3.5	5	10	115	140	95	382	10	549	11	4	12.8

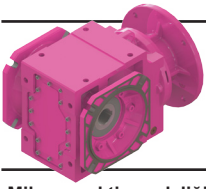

Ölçü Sayfaları Dimension Pages Abmessungenseiten

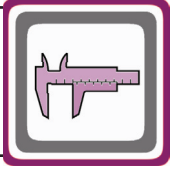

-Mil ucu çekirme deliği DIN 332 sayfa 2 / Tapped center hole to DIN 332, sheet 2 / Zentrierung mit Gewinde DIN 332, Blatt 2

KN285.08
KN286.08

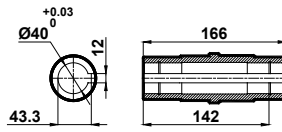
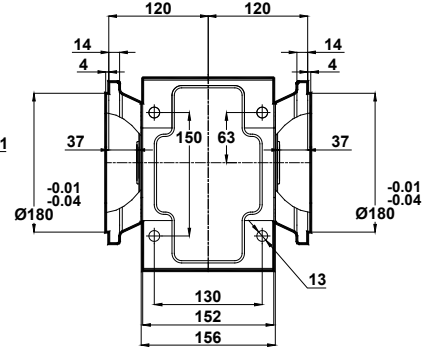
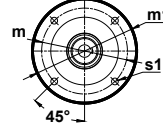
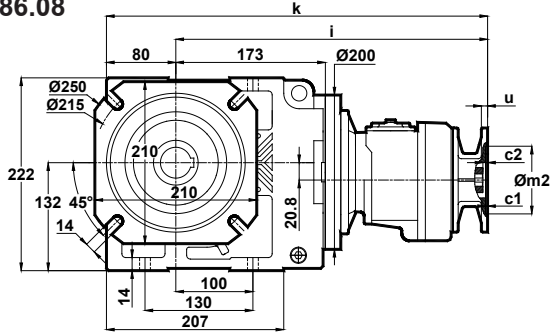

Opsiyonel flanş ölçüleri için sayfa 587'ye bakınız.
Please see on page 587 for optional flange dimensions
Siehe Seite 587 für auswählbare Flanschabmessungen

	c1	c2	s1	m	m1	m2	i	u	k	d1	t1	e1
63/B5	3.5	5	10	115	140	95	382	10	549	11	4	12.8

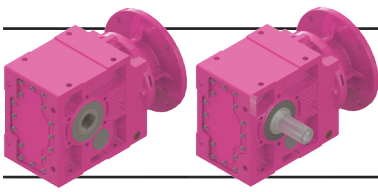

Ölçü Sayfaları

Dimension Pages

Abmessungsseiten

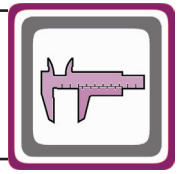

-Mil ucu çekirme deliği DIN 332 sayfa 2 / Tapped center hole to DIN 332, sheet 2 / Zentrierung mit Gewinde DIN 332, Blatt 2

KN373.00

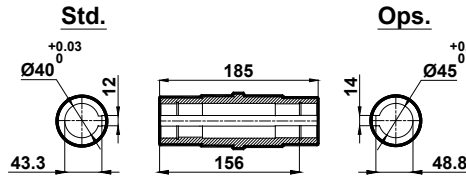
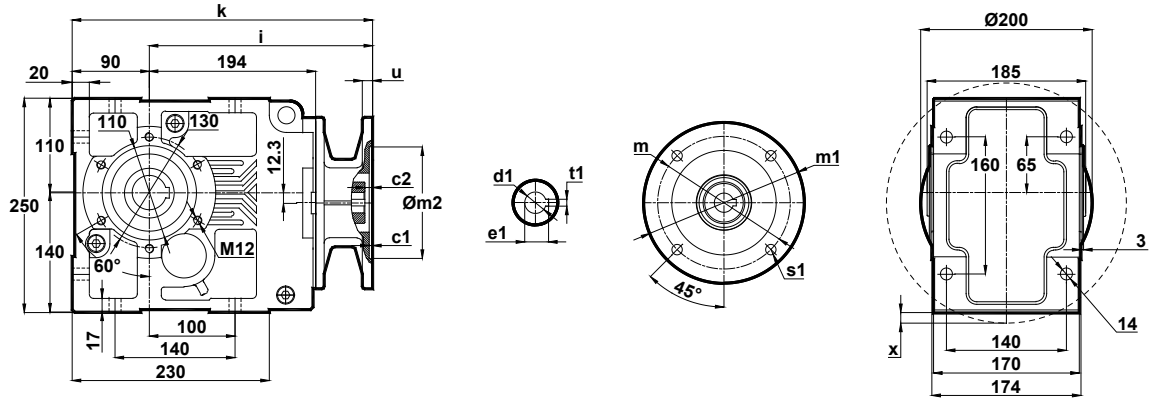

x: Motor Ayak bağlantı yüzeyinin altında ise
x: If Motor is lower than foot mounting plane
x: Wenn der Motor unter der Fußmontageebene ist

	c1	c2	s1	m	m1	m2	i	u	k	d1	t1	e1	x
71/B5	4	9	11	130	160	110	260.5	12	350.5	14	5	16.3	-
80/B5	4	9	12	165	200	130	260.5	12	350.5	19	6	21.8	-
80/B14	4	9	7	100	120	80	260.5	12	350.5	19	6	21.8	-
90/B5	4	9	12	165	200	130	260.5	12	350.5	24	8	27.3	-
90/B14	4	9	9	115	140	95	260.5	12	350.5	24	8	27.3	-
100/B5	4.5	9	15	215	250	180	277.5	15	367.5	28	8	31.3	-
100/B14	4	9	9	130	160	110	277.5	15	367.5	28	8	31.3	-
112/B5	4.5	9	15	215	250	180	277.5	15	367.5	28	8	31.3	-
112/B14	4	9	9	130	160	110	277.5	15	367.5	28	8	31.3	-
132/B5	4.5	7	15	265	300	230	297.5	15	387.5	38	10	41.3	22.3
132/B14	4.5	7	11	165	200	130	297.5	15	387.5	38	10	41.3	-

KN373.01

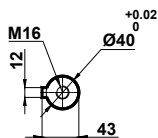
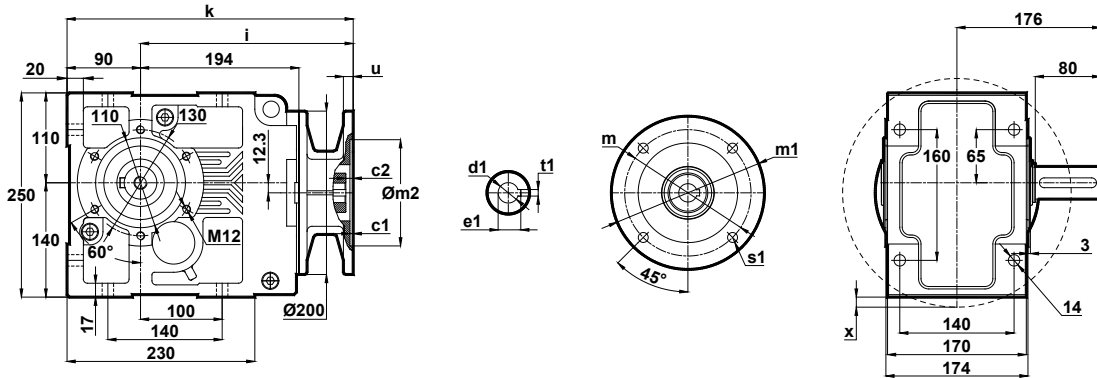

x: Motor Ayak bağlantı yüzeyinin altında ise
x: If Motor is lower than foot mounting plane
x: Wenn der Motor unter der Fußmontageebene ist

	c1	c2	s1	m	m1	m2	i	u	k	d1	t1	e1	x
71/B5	4	9	11	130	160	110	260.5	12	350.5	14	5	16.3	-
80/B5	4	9	12	165	200	130	260.5	12	350.5	19	6	21.8	-
80/B14	4	9	7	100	120	80	260.5	12	350.5	19	6	21.8	-
90/B5	4	9	12	165	200	130	260.5	12	350.5	24	8	27.3	-
90/B14	4	9	9	115	140	95	260.5	12	350.5	24	8	27.3	-
100/B5	4.5	9	15	215	250	180	277.5	15	367.5	28	8	31.3	-
100/B14	4	9	9	130	160	110	277.5	15	367.5	28	8	31.3	-
112/B5	4.5	9	15	215	250	180	277.5	15	367.5	28	8	31.3	-
112/B14	4	9	9	130	160	110	277.5	15	367.5	28	8	31.3	-
132/B5	4.5	7	15	265	300	230	297.5	15	387.5	38	10	41.3	22.3
132/B14	4.5	7	11	165	200	130	297.5	15	387.5	38	10	41.3	-

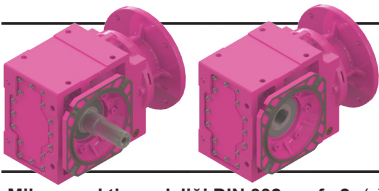

Ölçü Sayfaları

Dimension Pages

Abmessungsseiten

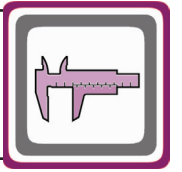

-Mil ucu çekirme deliği DIN 332 sayfa 2 / Tapped center hole to DIN 332, sheet 2 / Zentrierung mit Gewinde DIN 332, Blatt 2

KN373.02

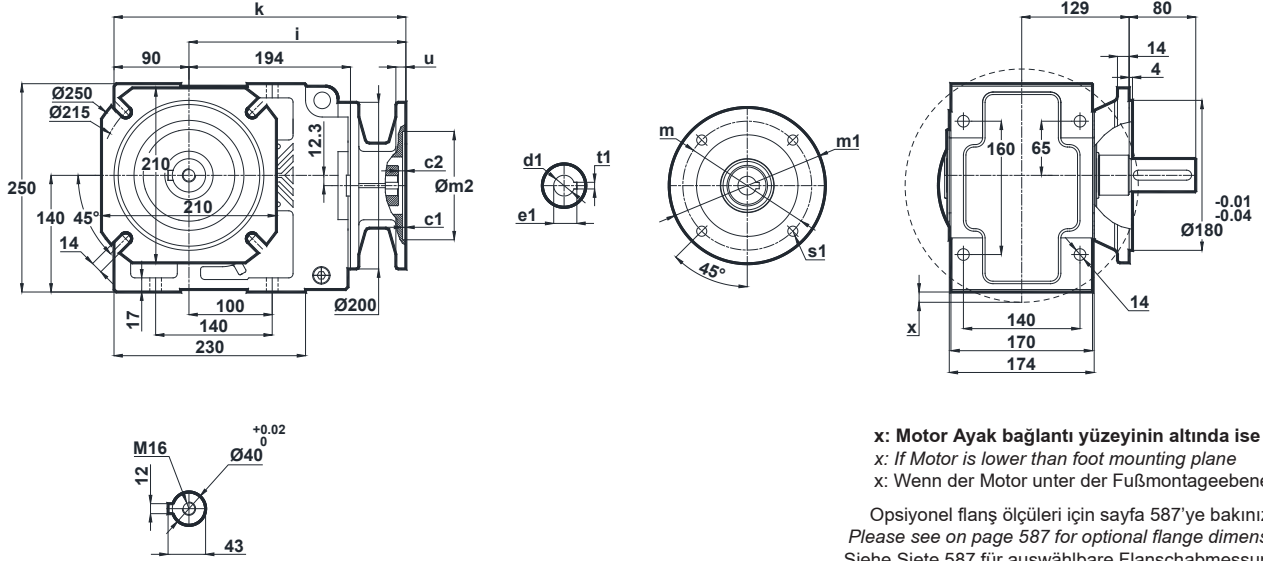

	c1	c2	s1	m	m1	m2	i	u	k	d1	t1	e1	x
71/B5	4	9	11	130	160	110	260.5	12	350.5	14	5	16.3	-
80/B5	4	9	12	165	200	130	260.5	12	350.5	19	6	21.8	-
80/B14	4	9	7	100	120	80	260.5	12	350.5	19	6	21.8	-
90/B5	4	9	12	165	200	130	260.5	12	350.5	24	8	27.3	-
90/B14	4	9	9	115	140	95	260.5	12	350.5	24	8	27.3	-
100/B5	4.5	9	15	215	250	180	277.5	15	367.5	28	8	31.3	-
100/B14	4	9	9	130	160	110	277.5	15	367.5	28	8	31.3	-
112/B5	4.5	9	15	215	250	180	277.5	15	367.5	28	8	31.3	-
112/B14	4	9	9	130	160	110	277.5	15	367.5	28	8	31.3	-
132/B5	4.5	7	15	265	300	230	297.5	15	387.5	38	10	41.3	22.3
132/B14	4.5	7	11	165	200	130	297.5	15	387.5	38	10	41.3	-

KN373.03

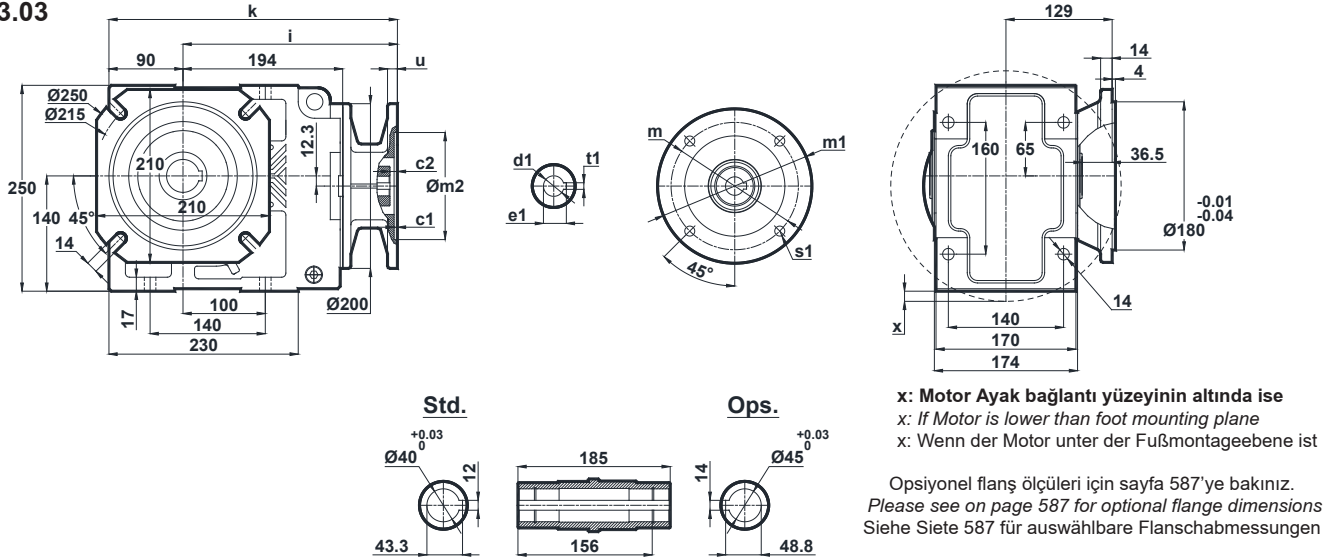

	c1	c2	s1	m	m1	m2	i	u	k	d1	t1	e1	x
71/B5	4	9	11	130	160	110	260.5	12	350.5	14	5	16.3	-
80/B5	4	9	12	165	200	130	260.5	12	350.5	19	6	21.8	-
80/B14	4	9	7	100	120	80	260.5	12	350.5	19	6	21.8	-
90/B5	4	9	12	165	200	130	260.5	12	350.5	24	8	27.3	-
90/B14	4	9	9	115	140	95	260.5	12	350.5	24	8	27.3	-
100/B5	4.5	9	15	215	250	180	277.5	15	367.5	28	8	31.3	-
100/B14	4	9	9	130	160	110	277.5	15	367.5	28	8	31.3	-
112/B5	4.5	9	15	215	250	180	277.5	15	367.5	28	8	31.3	-
112/B14	4	9	9	130	160	110	277.5	15	367.5	28	8	31.3	-
132/B5	4.5	7	15	265	300	230	297.5	15	387.5	38	10	41.3	22.3
132/B14	4.5	7	11	165	200	130	297.5	15	387.5	38	10	41.3	-

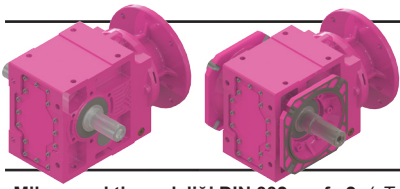

Ölçü Sayfaları

Dimension Pages

Abmessungsseiten

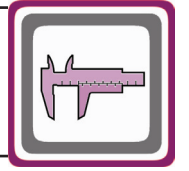

-Mil ucu çektirme deliği DIN 332 sayfa 2 / Tapped center hole to DIN 332, sheet 2 / Zentrierung mit Gewinde DIN 332, Blatt 2

KN373.04

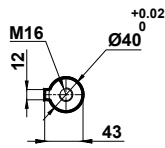
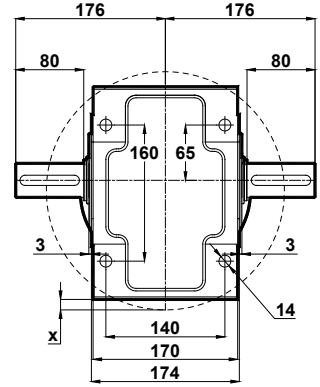
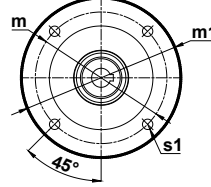
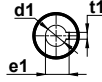
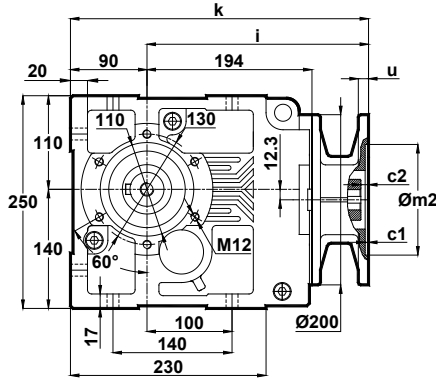

x: Motor Ayak bağlantı yüzeyinin altında ise
x: If Motor is lower than foot mounting plane
x: Wenn der Motor unter der Fußmontageebene ist

	c1	c2	s1	m	m1	m2	i	u	k	d1	t1	e1	x
71/B5	4	9	11	130	160	110	260.5	12	350.5	14	5	16.3	-
80/B5	4	9	12	165	200	130	260.5	12	350.5	19	6	21.8	-
80/B14	4	9	7	100	120	80	260.5	12	350.5	19	6	21.8	-
90/B5	4	9	12	165	200	130	260.5	12	350.5	24	8	27.3	-
90/B14	4	9	9	115	140	95	260.5	12	350.5	24	8	27.3	-
100/B5	4.5	9	15	215	250	180	277.5	15	367.5	28	8	31.3	-
100/B14	4	9	9	130	160	110	277.5	15	367.5	28	8	31.3	-
112/B5	4.5	9	15	215	250	180	277.5	15	367.5	28	8	31.3	-
112/B14	4	9	9	130	160	110	277.5	15	367.5	28	8	31.3	-
132/B5	4.5	7	15	265	300	230	297.5	15	387.5	38	10	41.3	22.3
132/B14	4.5	7	11	165	200	130	297.5	15	387.5	38	10	41.3	-

KN373.05

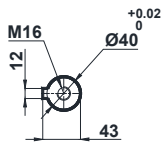
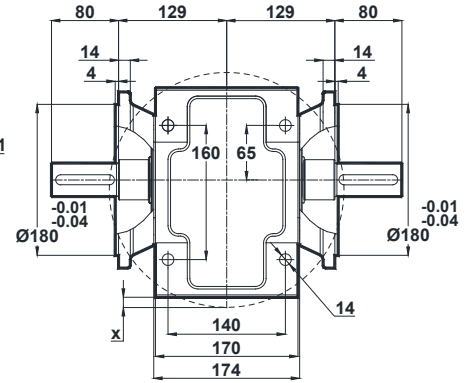
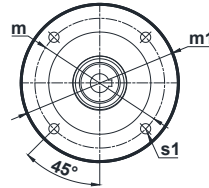
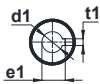
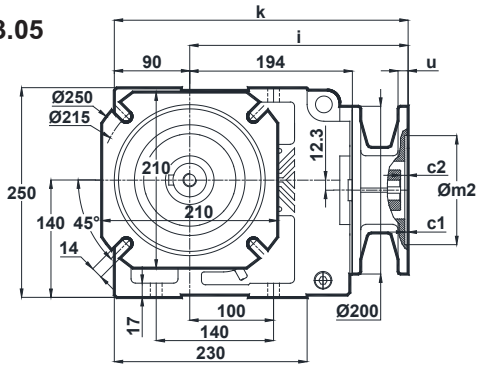

x: Motor Ayak bağlantı yüzeyinin altında ise
x: If Motor is lower than foot mounting plane
x: Wenn der Motor unter der Fußmontageebene ist

Opsiyonel flanş ölçüleri için sayfa 587'ye bakınız.
Please see on page 587 for optional flange dimensions
Siehe Seite 587 für auswählbare Flanschabmessungen

	c1	c2	s1	m	m1	m2	i	u	k	d1	t1	e1	x
71/B5	4	9	11	130	160	110	260.5	12	350.5	14	5	16.3	-
80/B5	4	9	12	165	200	130	260.5	12	350.5	19	6	21.8	-
80/B14	4	9	7	100	120	80	260.5	12	350.5	19	6	21.8	-
90/B5	4	9	12	165	200	130	260.5	12	350.5	24	8	27.3	-
90/B14	4	9	9	115	140	95	260.5	12	350.5	24	8	27.3	-
100/B5	4.5	9	15	215	250	180	277.5	15	367.5	28	8	31.3	-
100/B14	4	9	9	130	160	110	277.5	15	367.5	28	8	31.3	-
112/B5	4.5	9	15	215	250	180	277.5	15	367.5	28	8	31.3	-
112/B14	4	9	9	130	160	110	277.5	15	367.5	28	8	31.3	-
132/B5	4.5	7	15	265	300	230	297.5	15	387.5	38	10	41.3	22.3
132/B14	4.5	7	11	165	200	130	297.5	15	387.5	38	10	41.3	-

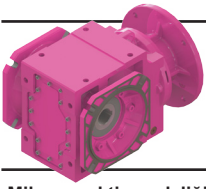

Ölçü Sayfaları Dimension Pages Abmessungenseiten

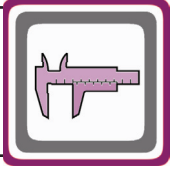

-Mil ucu çektirme deliği DIN 332 sayfa 2 / Tapped center hole to DIN 332, sheet 2 / Zentrierung mit Gewinde DIN 332, Blatt 2

KN373.08

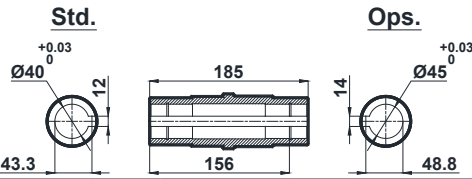
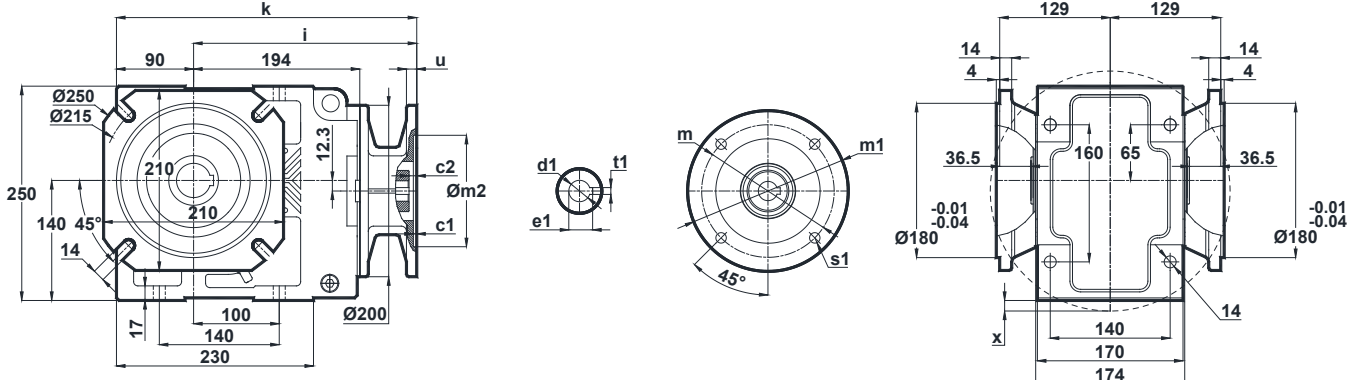

x: Motor Ayak bağlantı yüzeyinin altında ise
x: If Motor is lower than foot mounting plane
x: Wenn der Motor unter der Fußmontageebene ist

Opsiyonel flanş ölçüleri için sayfa 587'ye bakınız.
Please see on page 587 for optional flange dimensions
Siehe Seite 587 für auswählbare Flanschabmessungen

	c1	c2	s1	m	m1	m2	i	u	k	d1	t1	e1	x
71/B5	4	9	11	130	160	110	260.5	12	350.5	14	5	16.3	-
80/B5	4	9	12	165	200	130	260.5	12	350.5	19	6	21.8	-
80/B14	4	9	7	100	120	80	260.5	12	350.5	19	6	21.8	-
90/B5	4	9	12	165	200	130	260.5	12	350.5	24	8	27.3	-
90/B14	4	9	9	115	140	95	260.5	12	350.5	24	8	27.3	-
100/B5	4.5	9	15	215	250	180	277.5	15	367.5	28	8	31.3	-
100/B14	4	9	9	130	160	110	277.5	15	367.5	28	8	31.3	-
112/B5	4.5	9	15	215	250	180	277.5	15	367.5	28	8	31.3	-
112/B14	4	9	9	130	160	110	277.5	15	367.5	28	8	31.3	-
132/B5	4.5	7	15	265	300	230	297.5	15	387.5	38	10	41.3	22.3
132/B14	4.5	7	11	165	200	130	297.5	15	387.5	38	10	41.3	-

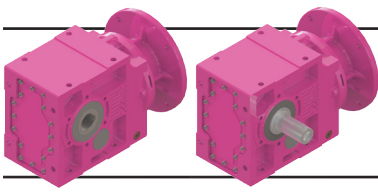

Ölçü Sayfaları

Dimension Pages

Abmessungsseiten

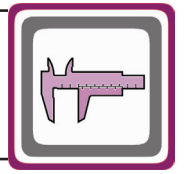

-Mil ucu çekirme deliği DIN 332 sayfa 2 / Tapped center hole to DIN 332, sheet 2 / Zentrierung mit Gewinde DIN 332, Blatt 2

KN374.00

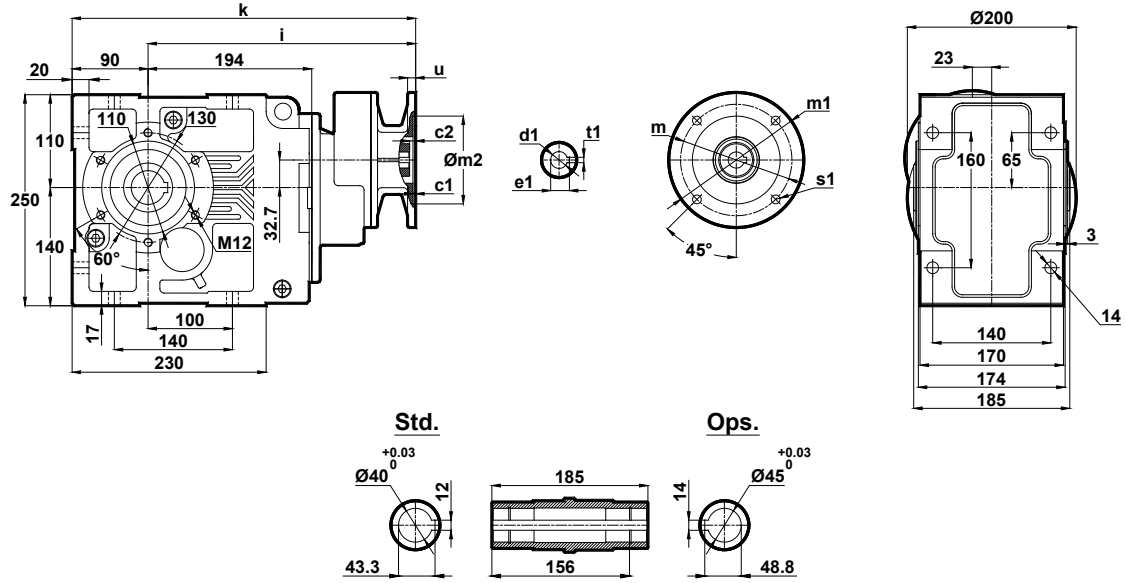

	c1	c2	s1	m	m1	m2	i	u	k	d1	t1	e1
63/B5	3.5	5	9	115	140	95	337.5	12	427.5	11	4	12.8
71/B5	4	8.5	11	130	160	110	308.5	12	398.5	14	5	16.3
71/B14	3		7	85	105	70		10				
80/B5	4	5	12	165	200	130	337.5	12	427.5	19	6	21.8
80/B14			7	100	120	80						

KN374.01

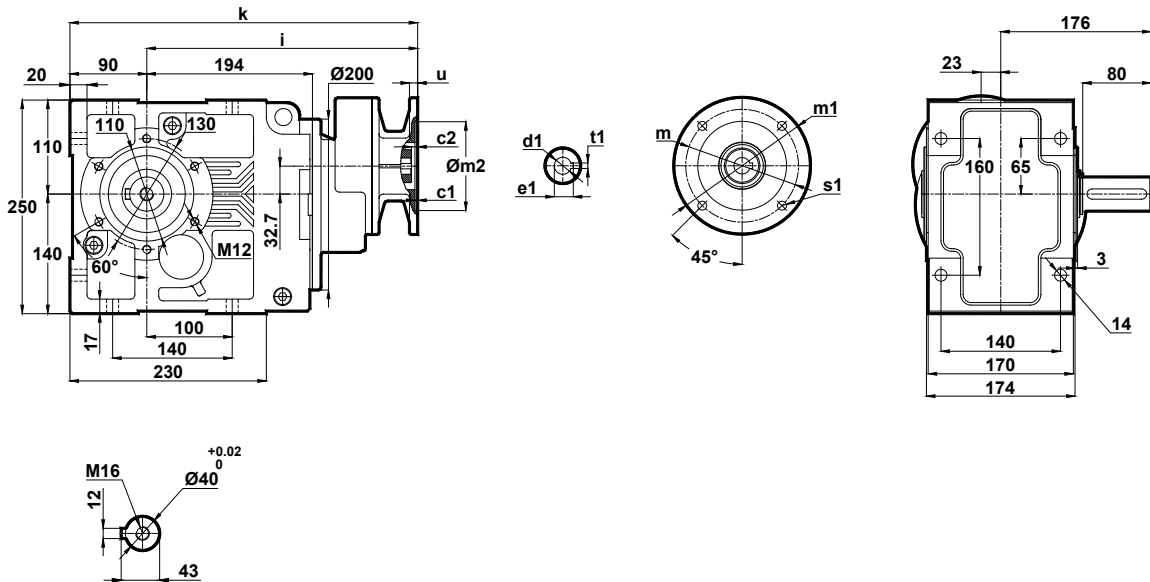

	c1	c2	s1	m	m1	m2	i	u	k	d1	t1	e1
63/B5	3.5	5	9	115	140	95	337.5	12	427.5	11	4	12.8
71/B5	4	8.5	11	130	160	110	308.5	12	398.5	14	5	16.3
71/B14	3		7	85	105	70		10				
80/B5	4	5	12	165	200	130	337.5	12	427.5	19	6	21.8
80/B14			7	100	120	80						

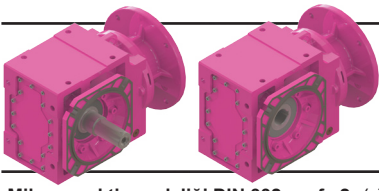

Ölçü Sayfaları

Dimension Pages

Abmessungsseiten

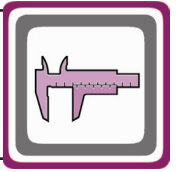

-Mil ucu çekirme deliği DIN 332 sayfa 2 / Tapped center hole to DIN 332, sheet 2 / Zentrierung mit Gewinde DIN 332, Blatt 2

KN374.02

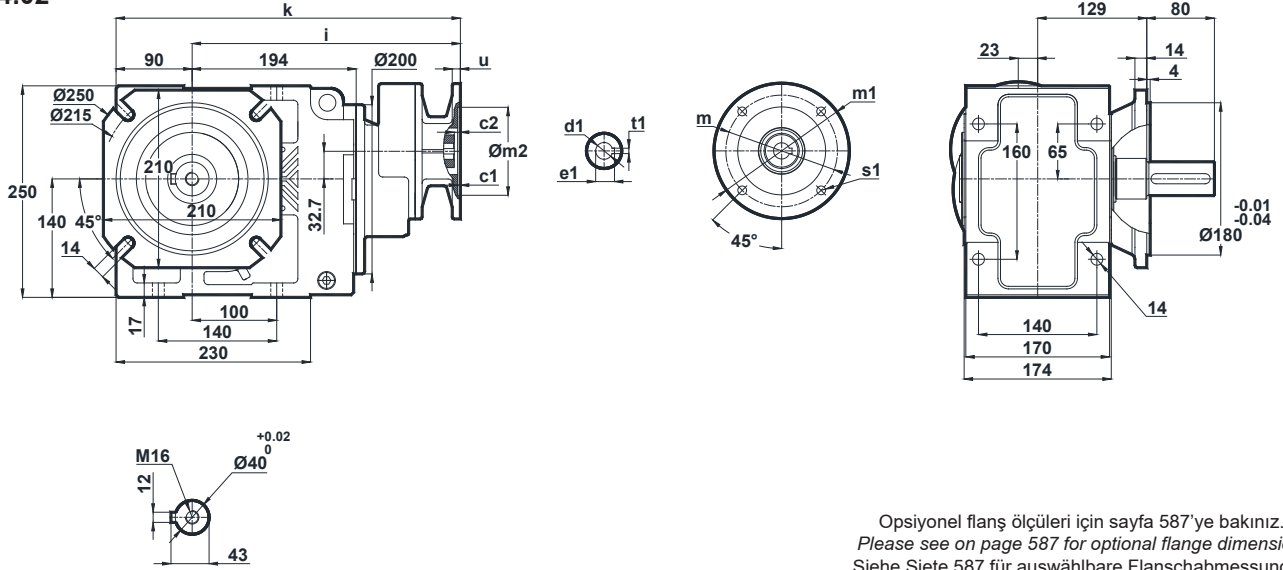

Opsiyonel flanş ölçüleri için sayfa 587'ye bakınız.
Please see on page 587 for optional flange dimensions
Siehe Siete 587 für auswählbare Flanschabmessungen

	c1	c2	s1	m	m1	m2	i	u	k	d1	t1	e1
63/B5	3.5	5	9	115	140	95	337.5	12	427.5	11	4	12.8
71/B5	4	8.5	11	130	160	110	308.5	12	398.5	14	5	16.3
71/B14	3		7	85	105	70		10				
80/B5	4	5	12	165	200	130	337.5	12	427.5	19	6	21.8
80/B14			7	100	120	80						

KN374.03

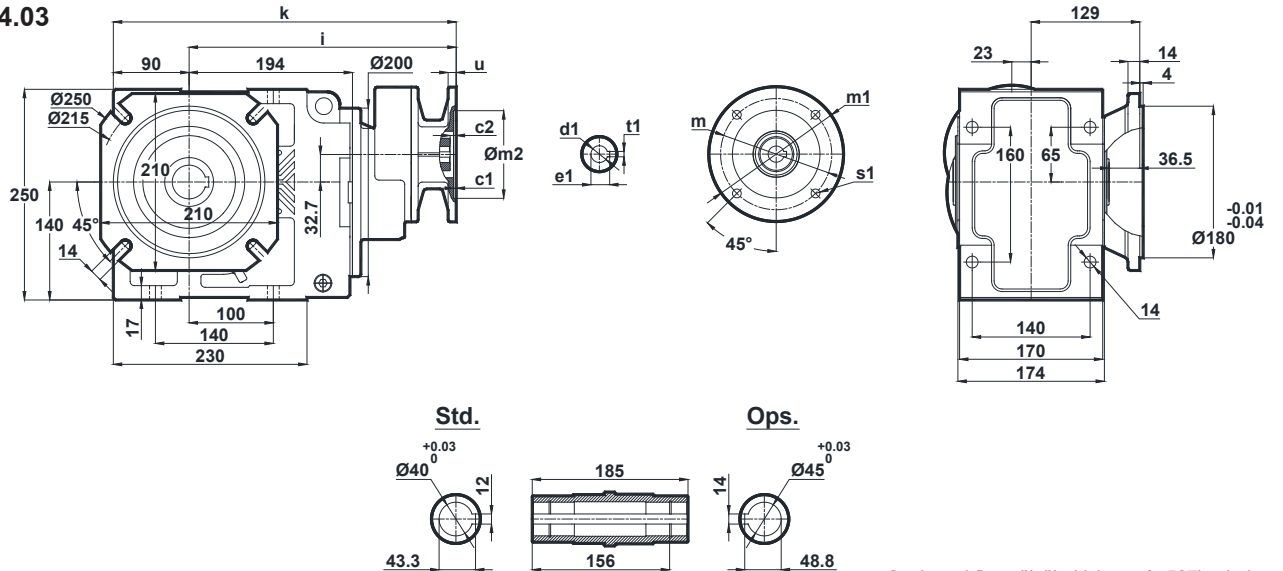

Opsiyonel flanş ölçüleri için sayfa 587'ye bakınız.
Please see on page 587 for optional flange dimensions
Siehe Siete 587 für auswählbare Flanschabmessungen

	c1	c2	s1	m	m1	m2	i	u	k	d1	t1	e1
63/B5	3.5	5	9	115	140	95	337.5	12	427.5	11	4	12.8
71/B5	4	8.5	11	130	160	110	308.5	12	398.5	14	5	16.3
71/B14	3		7	85	105	70		10				
80/B5	4	5	12	165	200	130	337.5	12	427.5	19	6	21.8
80/B14			7	100	120	80						

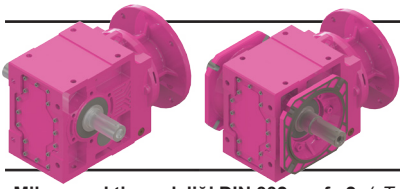

Ölçü Sayfaları

Dimension Pages

Abmessungsseiten

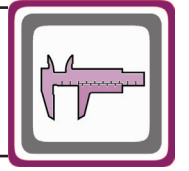

-Mil ucu çekirme deliği DIN 332 sayfa 2 / Tapped center hole to DIN 332, sheet 2 / Zentrierung mit Gewinde DIN 332, Blatt 2

KN374.04

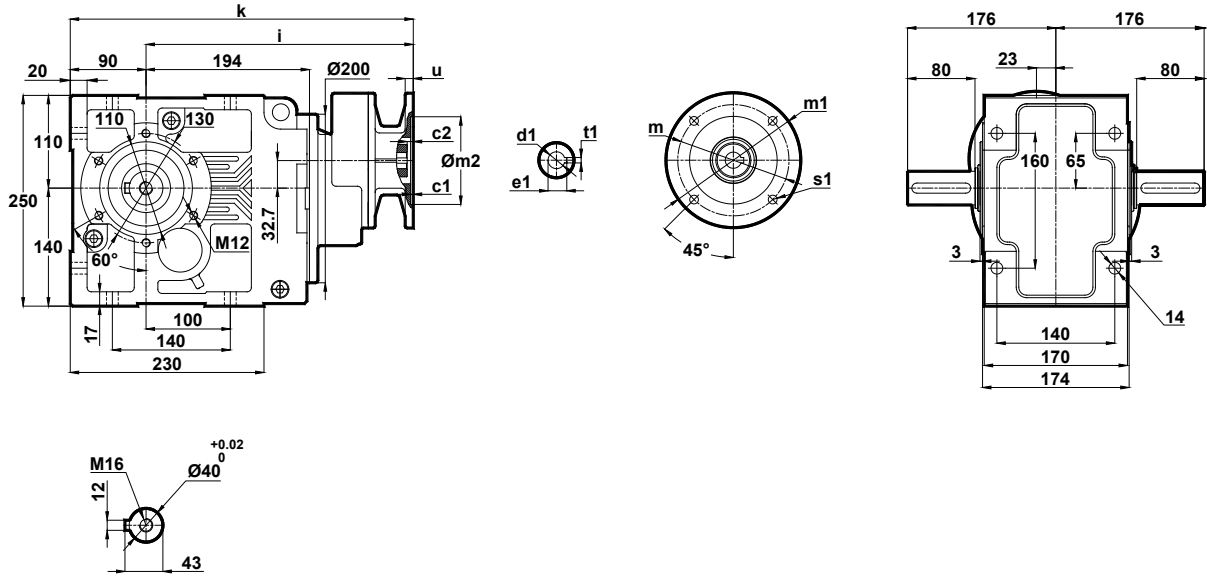

	c1	c2	s1	m	m1	m2	i	u	k	d1	t1	e1
63/B5	3.5	5	9	115	140	95	337.5	12	427.5	11	4	12.8
71/B5	4	8.5	11	130	160	110	308.5	12	398.5	14	5	16.3
71/B14	3		7	85	105	70		10				
80/B5	4	5	12	165	200	130	337.5	12	427.5	19	6	21.8
80/B14			7	100	120	80						

KN374.05

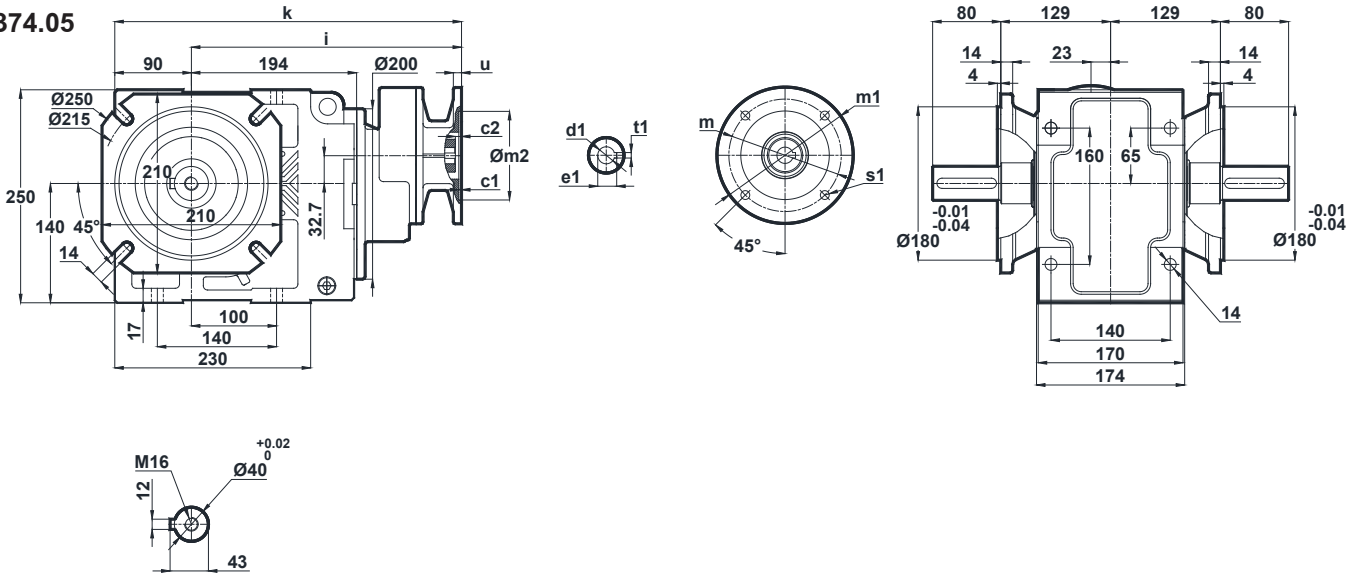

Opsiyonel flanş ölçüleri için sayfa 587'ye bakınız.
Please see on page 587 for optional flange dimensions
Siehe Seite 587 für auswählbare Flanschabmessungen

	c1	c2	s1	m	m1	m2	i	u	k	d1	t1	e1
63/B5	3.5	5	9	115	140	95	337.5	12	427.5	11	4	12.8
71/B5	4	8.5	11	130	160	110	308.5	12	398.5	14	5	16.3
71/B14	3		7	85	105	70		10				
80/B5	4	5	12	165	200	130	337.5	12	427.5	19	6	21.8
80/B14			7	100	120	80						

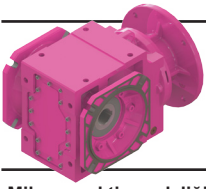

Ölçü Sayfaları Dimension Pages Abmessungenseiten

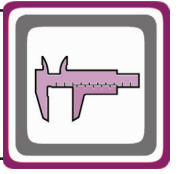

-Mil ucu çektirme deliği DIN 332 sayfa 2 / Tapped center hole to DIN 332, sheet 2 / Zentrierung mit Gewinde DIN 332, Blatt 2

KN374.08

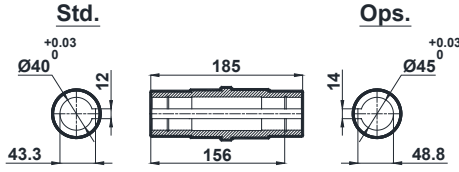
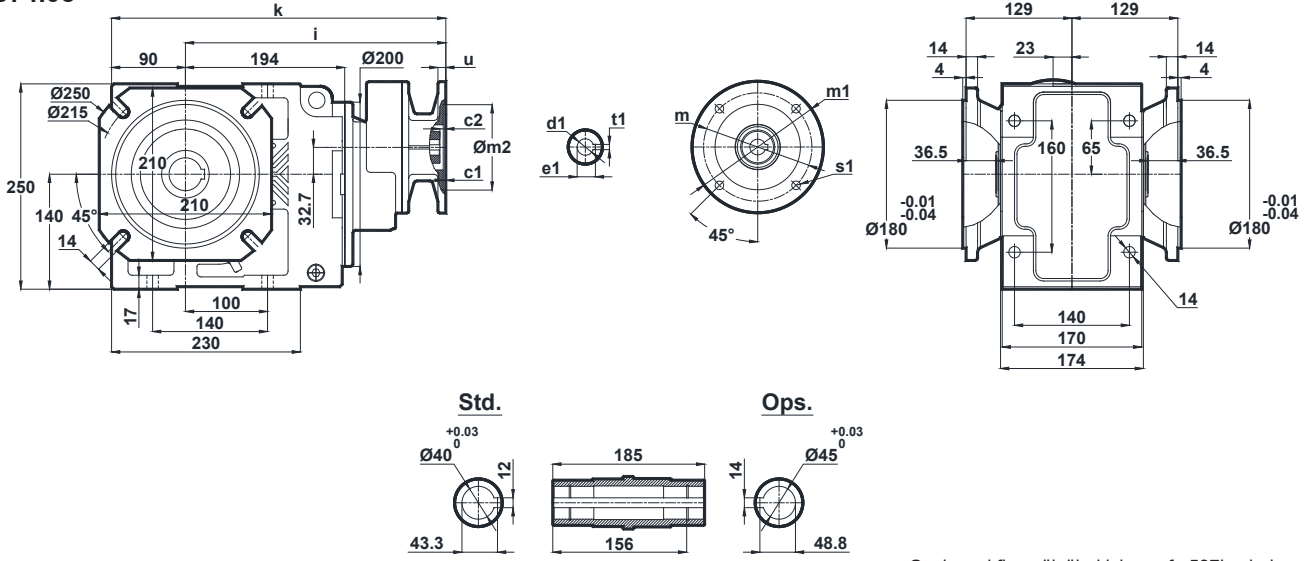

Opsiyonel flanş ölçüleri için sayfa 587'ye bakınız.
Please see on page 587 for optional flange dimensions
Siehe Seite 587 für auswählbare Flanschabmessungen

	c1	c2	s1	m	m1	m2	i	u	k	d1	t1	e1
63/B5	3.5	5	9	115	140	95	337.5	12	427.5	11	4	12.8
71/B5	4			130	160	110		12				
71/B14	3	8.5	7	85	105	70	308.5	10	398.5	14	5	16.3
80/B5	4	5	12	165	200	130	337.5	12	427.5	19	6	21.8
80/B14			7	100	120	80						

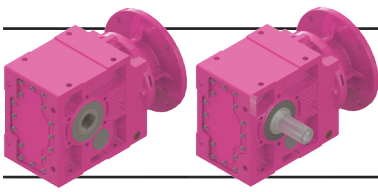

Ölçü Sayfaları

Dimension Pages

Abmessungsseiten

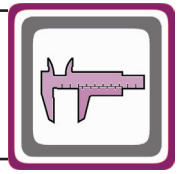

-Mil ucu çekirme deliği DIN 332 sayfa 2 / Tapped center hole to DIN 332, sheet 2 / Zentrierung mit Gewinde DIN 332, Blatt 2

KN375.00
KN376.00

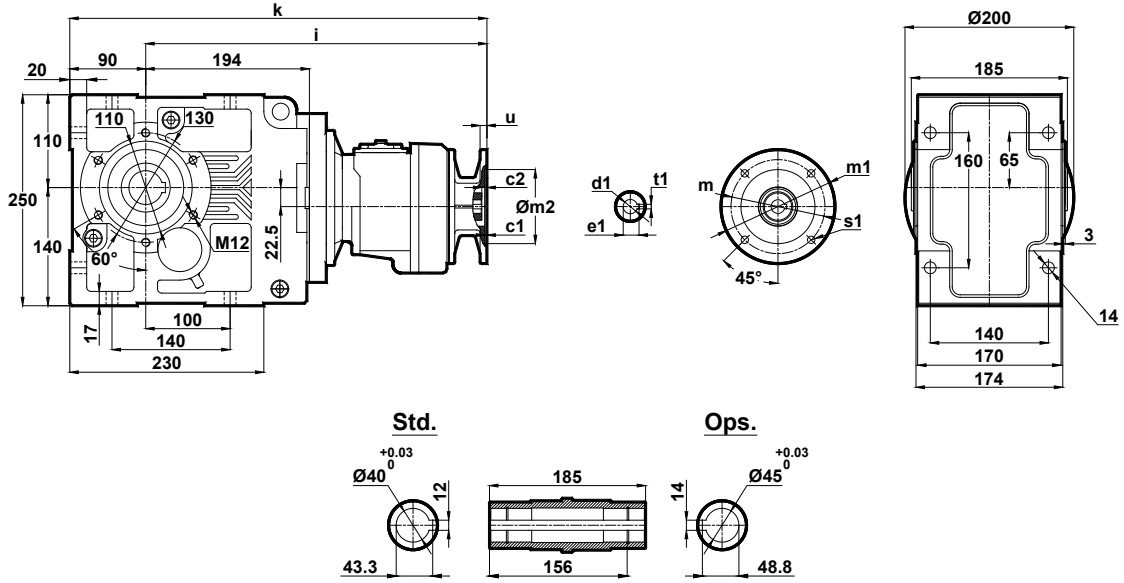

	c1	c2	s1	m	m1	m2	i	u	k	d1	t1	e1
63/B5	3.5	5	10	115	140	95	403	10	493	11	4	12.8
63/B14	2.5	5	5.5	75	90	60	60	10	493	11	4	12.8
71/B5	4	4.5	11	130	160	110	404.5	12	494.5	14	5	16.3
71/B14	3	4.5	7	85	105	70	404.5	10	494.5	14	5	16.3

KN375.01
KN376.01

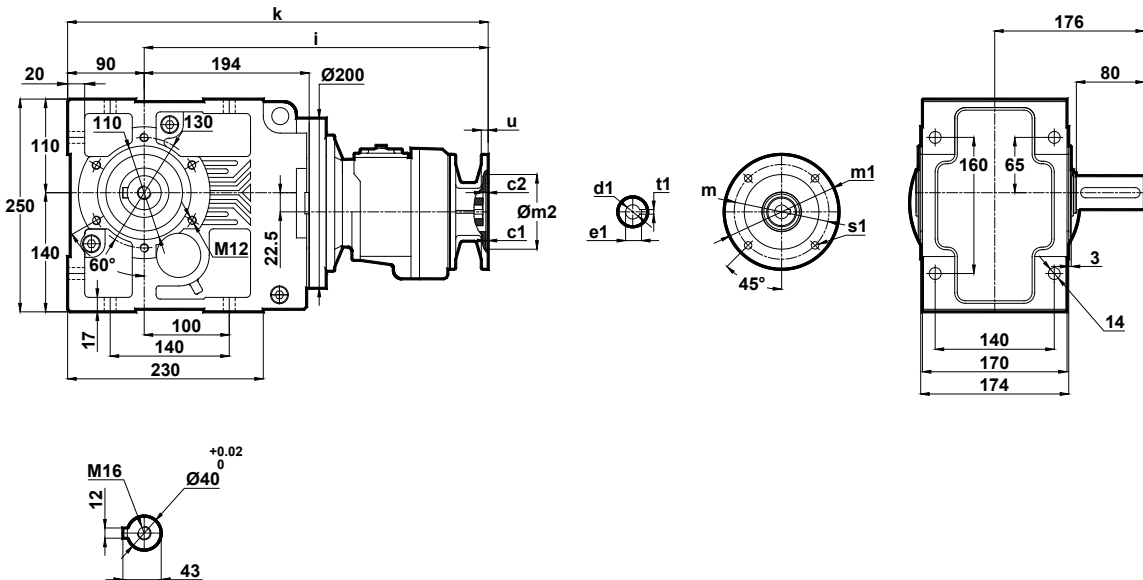

	c1	c2	s1	m	m1	m2	i	u	k	d1	t1	e1
63/B5	3.5	5	10	115	140	95	403	10	493	11	4	12.8
63/B14	2.5	5	5.5	75	90	60	60	10	493	11	4	12.8
71/B5	4	4.5	11	130	160	110	404.5	12	494.5	14	5	16.3
71/B14	3	4.5	7	85	105	70	404.5	10	494.5	14	5	16.3

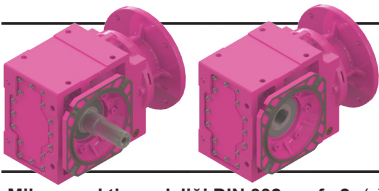

Ölçü Sayfaları

Dimension Pages

Abmessungsseiten

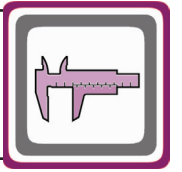

-Mil ucu çektirme deliği DIN 332 sayfa 2 / Tapped center hole to DIN 332, sheet 2 / Zentrierung mit Gewinde DIN 332, Blatt 2

KN375.02
KN376.02

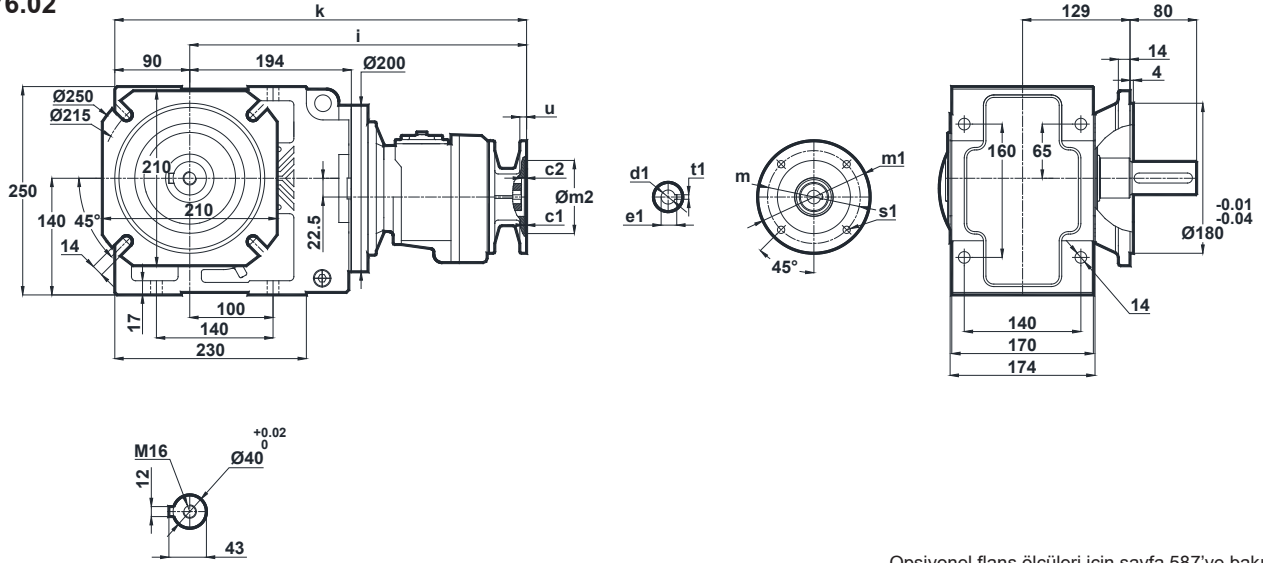

Opsiyonel flanş ölçüleri için sayfa 587'ye bakınız.
Please see on page 587 for optional flange dimensions
Siehe Seite 587 für auswählbare Flanschabmessungen

	c1	c2	s1	m	m1	m2	i	u	k	d1	t1	e1
63/B5	3.5	5	10	115	140	95	403	10	493	11	4	12.8
63/B14	2.5	5	5.5	75	90	60						
71/B5	4	4.5	11	130	160	110	404.5	12	494.5	14	5	16.3
71/B14	3	4.5	7	85	105	70						

KN375.03
KN376.03

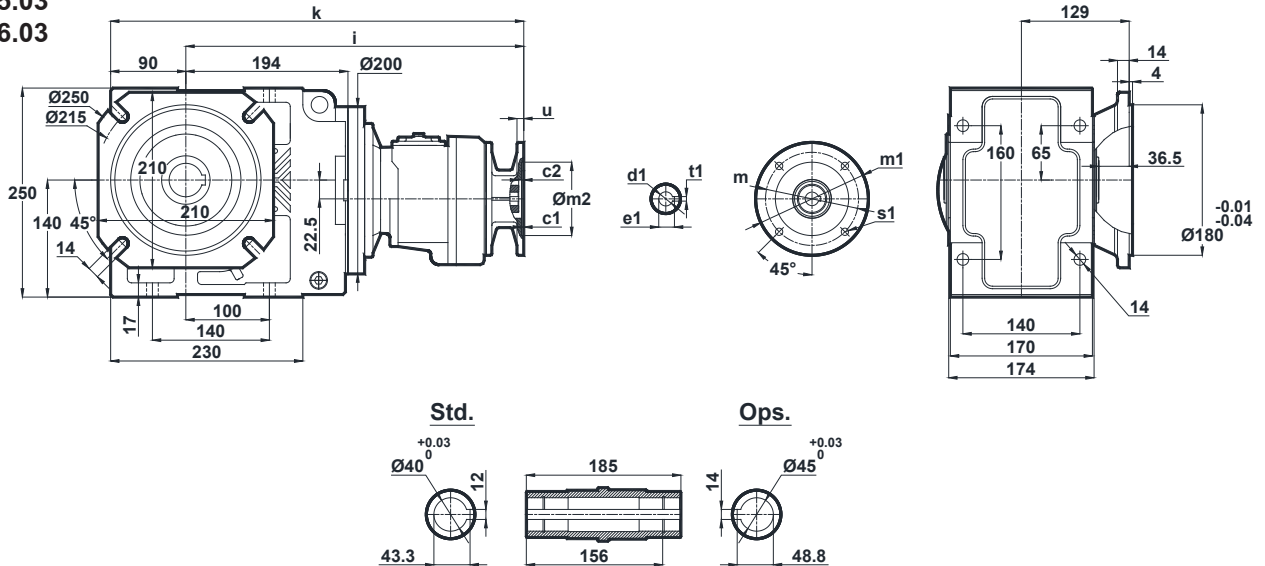

Opsiyonel flanş ölçüleri için sayfa 587'ye bakınız.
Please see on page 587 for optional flange dimensions
Siehe Seite 587 für auswählbare Flanschabmessungen

	c1	c2	s1	m	m1	m2	i	u	k	d1	t1	e1
63/B5	3.5	5	10	115	140	95	403	10	493	11	4	12.8
63/B14	2.5	5	5.5	75	90	60						
71/B5	4	4.5	11	130	160	110	404.5	12	494.5	14	5	16.3
71/B14	3	4.5	7	85	105	70						

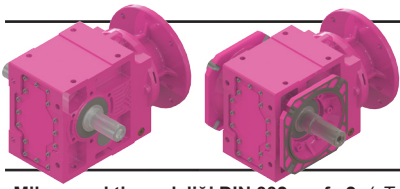

Ölçü Sayfaları

Dimension Pages

Abmessungsseiten

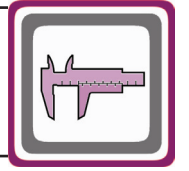

-Mil ucu çektirme deliği DIN 332 sayfa 2 / Tapped center hole to DIN 332, sheet 2 / Zentrierung mit Gewinde DIN 332, Blatt 2

KN375.04
KN376.04

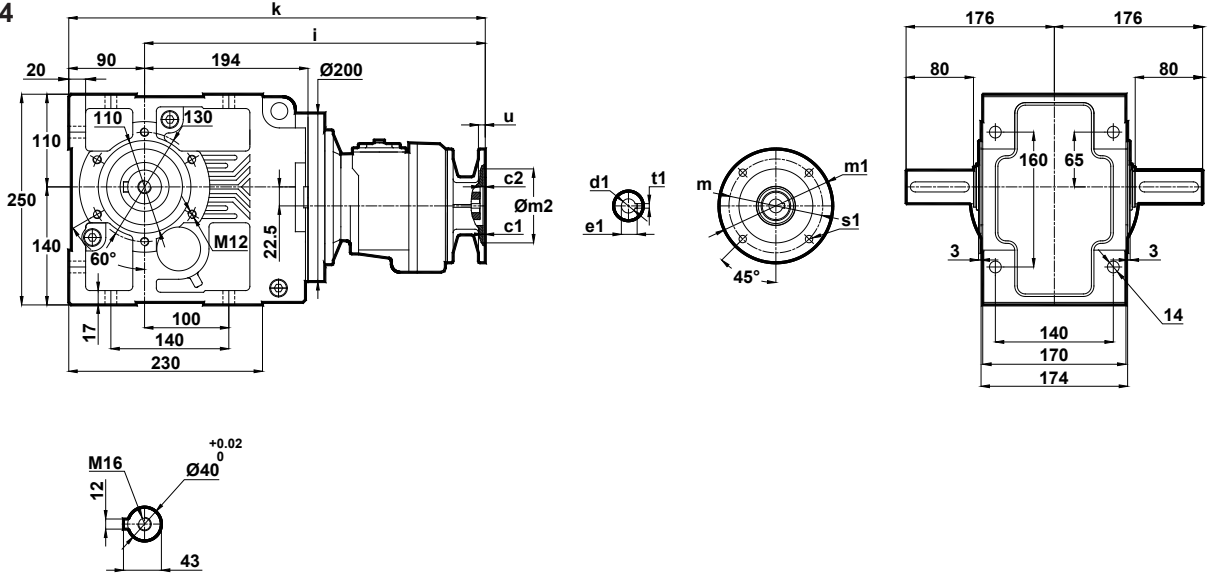

	c1	c2	s1	m	m1	m2	i	u	k	d1	t1	e1
63/B5	3.5	5	10	115	140	95	403	10	493	11	4	12.8
63/B14	2.5	5	5.5	75	90	60	403	10	493	11	4	12.8
71/B5	4	4.5	11	130	160	110	404.5	12	494.5	14	5	16.3
71/B14	3	4.5	7	85	105	70	404.5	10	494.5	14	5	16.3

KN375.05
KN376.05

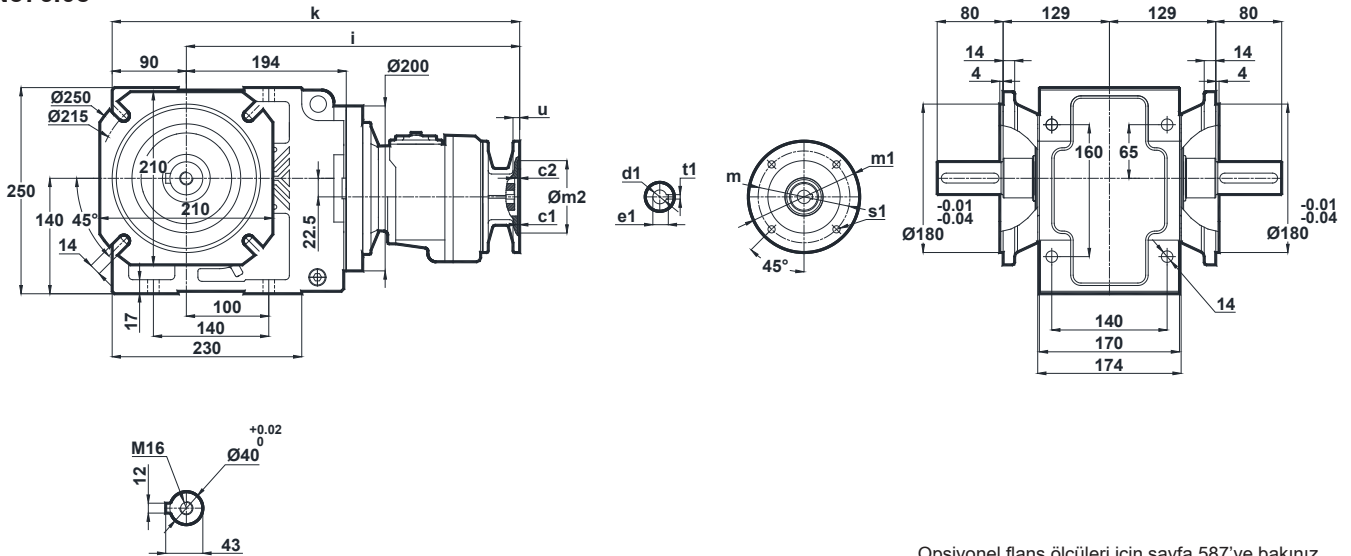

Opsiyonel flanş ölçüleri için sayfa 587'ye bakınız.
Please see on page 587 for optional flange dimensions
Siehe Seite 587 für auswählbare Flanschabmessungen

	c1	c2	s1	m	m1	m2	i	u	k	d1	t1	e1
63/B5	3.5	5	10	115	140	95	403	10	493	11	4	12.8
63/B14	2.5	5	5.5	75	90	60	403	10	493	11	4	12.8
71/B5	4	4.5	11	130	160	110	404.5	12	494.5	14	5	16.3
71/B14	3	4.5	7	85	105	70	404.5	10	494.5	14	5	16.3

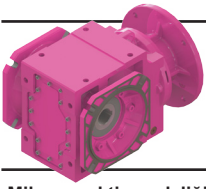

Ölçü Sayfaları Dimension Pages Abmessungsseiten

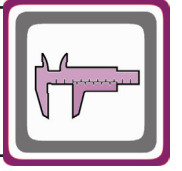

-Mil ucu çekirme deliği DIN 332 sayfa 2 / Tapped center hole to DIN 332, sheet 2 / Zentrierung mit Gewinde DIN 332, Blatt 2

KN375.08
KN376.08

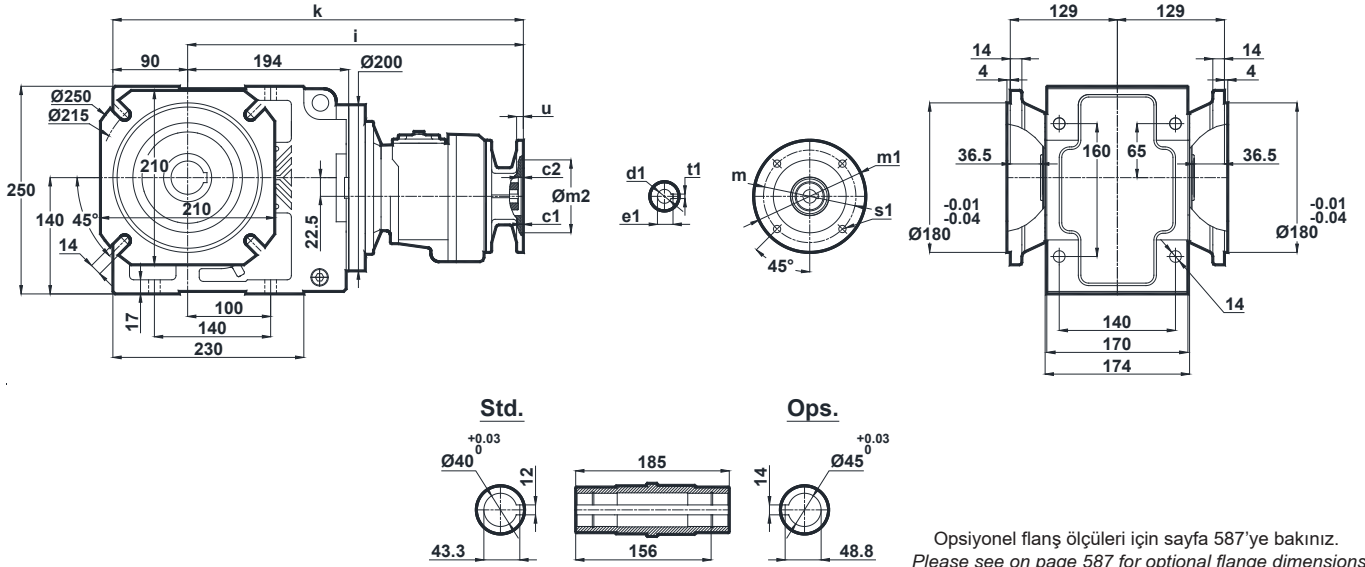

	c1	c2	s1	m	m1	m2	i	u	k	d1	t1	e1
63/B5	3.5	5	10	115	140	95	403	10	493	11	4	12.8
63/B14	2.5	5	5.5	75	90	60						
71/B5	4	4.5	11	130	160	110	404.5	12	494.5	14	5	16.3
71/B14	3	4.5	7	85	105	70		10				

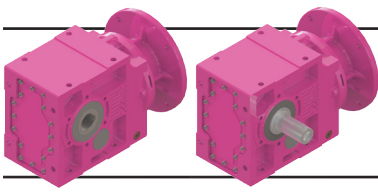

Ölçü Sayfaları

Dimension Pages

Abmessungsseiten

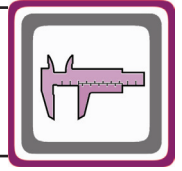

-Mil ucu çekirme deliği DIN 332 sayfa 2 / Tapped center hole to DIN 332, sheet 2 / Zentrierung mit Gewinde DIN 332, Blatt 2

KN473.00

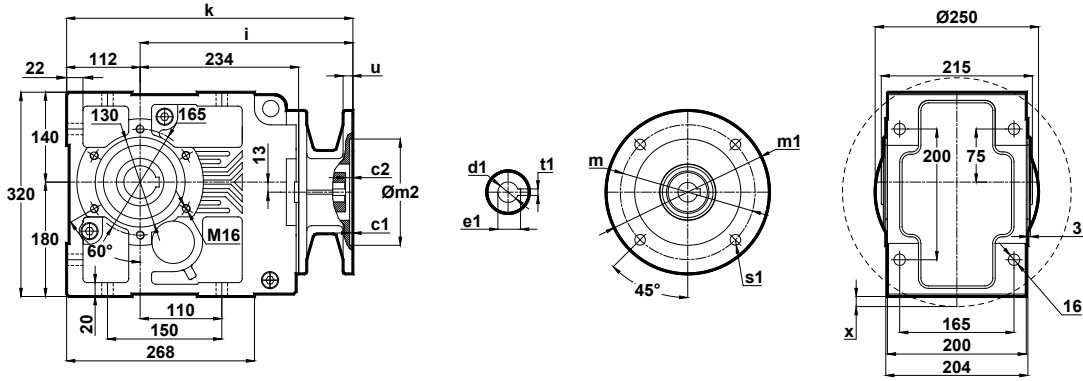

Std.

Ops.

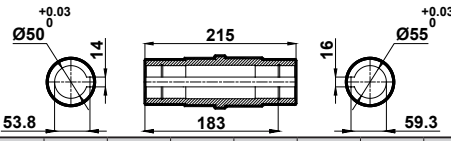

x: Motor Ayak bağlantı yüzeyinin altında ise
x: If Motor is lower than foot mounting plane
x: Wenn der Motor unter der Fußmontageebene ist

	c1	c2	s1	m	m1	m2	i	u	k	d1	t1	e1	x
80/B5	4	5	12	165	200	130	290.5	12	402.5	19	6	21.8	-
90/B5	4	5	12	165	200	130	290.5	12	402.5	24	8	27.3	-
90/B14	4	5	9	115	140	95	290.5	12	402.5	24	8	27.3	-
100/B5	4.5	9	15	215	250	180	309	15	421	28	8	31.3	-
100/B14	4	9	9	130	160	110	309	15	421	28	8	31.3	-
112/B5	4.5	9	15	215	250	180	309	15	421	28	8	31.3	-
112/B14	4	9	9	130	160	110	309	15	421	28	8	31.3	-
132/B5	4.5	6	15	265	300	230	327.5	15	439.5	38	10	41.3	-
132/B14	4.5	6	11	165	200	130	327.5	15	439.5	38	10	41.3	-
160/B5	5.5	10	19	300	350	250	407	20	519	42	12	45.3	8
180/B5	5.5	10	19	300	350	250	407	20	519	48	14	51.8	8

KN473.01

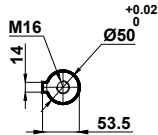
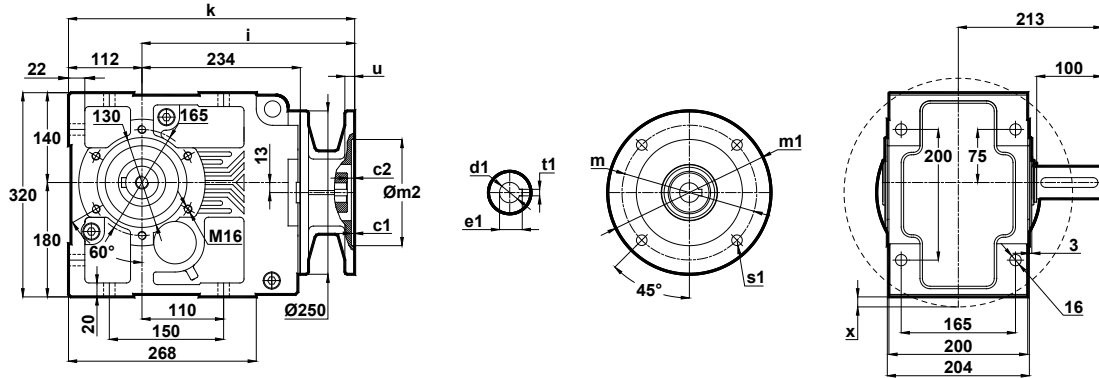

x: Motor Ayak bağlantı yüzeyinin altında ise
x: If Motor is lower than foot mounting plane
x: Wenn der Motor unter der Fußmontageebene ist

	c1	c2	s1	m	m1	m2	i	u	k	d1	t1	e1	x
80/B5	4	5	12	165	200	130	290.5	12	402.5	19	6	21.8	-
90/B5	4	5	12	165	200	130	290.5	12	402.5	24	8	27.3	-
90/B14	4	5	9	115	140	95	290.5	12	402.5	24	8	27.3	-
100/B5	4.5	9	15	215	250	180	309	15	421	28	8	31.3	-
100/B14	4	9	9	130	160	110	309	15	421	28	8	31.3	-
112/B5	4.5	9	15	215	250	180	309	15	421	28	8	31.3	-
112/B14	4	9	9	130	160	110	309	15	421	28	8	31.3	-
132/B5	4.5	6	15	265	300	230	327.5	15	439.5	38	10	41.3	-
132/B14	4.5	6	11	165	200	130	327.5	15	439.5	38	10	41.3	-
160/B5	5.5	10	19	300	350	250	407	20	519	42	12	45.3	8
180/B5	5.5	10	19	300	350	250	407	20	519	48	14	51.8	8

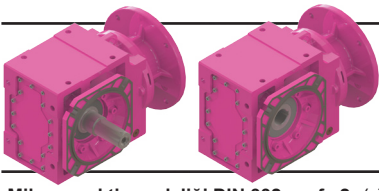

Ölçü Sayfaları

Dimension Pages

Abmessungsseiten

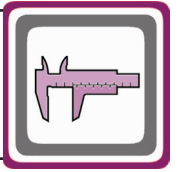

-Mil ucu çektirme deliği DIN 332 sayfa 2 / Tapped center hole to DIN 332, sheet 2 / Zentrierung mit Gewinde DIN 332, Blatt 2

KN473.02

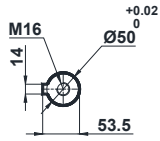
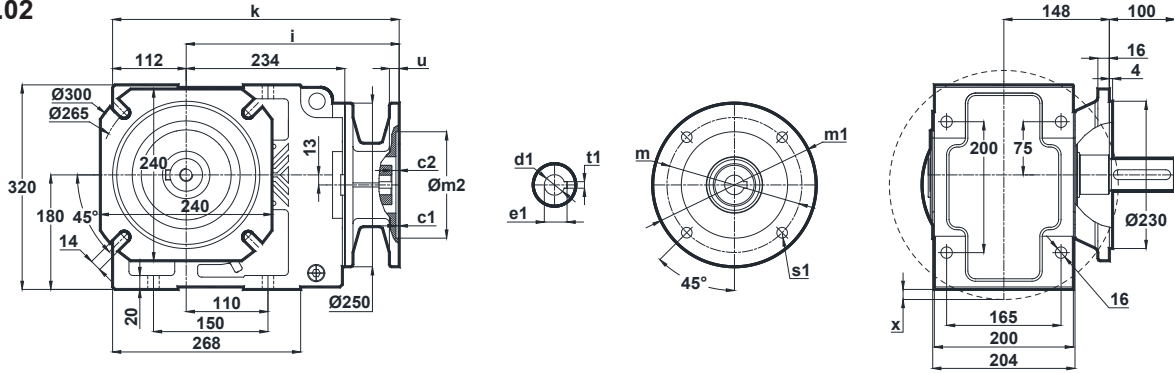

x: Motor Ayak bağlantı yüzeyinin altında ise
x: If Motor is lower than foot mounting plane
x: Wenn der Motor unter der Fußmontageebene ist

Opsiyonel flanş ölçüleri için sayfa 587'ye bakınız.
Please see on page 587 for optional flange dimensions
Siehe Siete 587 für auswählbare Flanschabmessungen

	c1	c2	s1	m	m1	m2	i	u	k	d1	t1	e1	x
80/B5	4	5	12	165	200	130	290.5	12	402.5	19	6	21.8	-
90/B5	4	5	12	165	200	130	290.5	12	402.5	24	8	27.3	-
90/B14	4	5	9	115	140	95	290.5	12	402.5	24	8	27.3	-
100/B5	4.5	9	15	215	250	180	309	15	421	28	8	31.3	-
100/B14	4	9	9	130	160	110	309	15	421	28	8	31.3	-
112/B5	4.5	9	15	215	250	180	309	15	421	28	8	31.3	-
112/B14	4	9	9	130	160	110	309	15	421	28	8	31.3	-
132/B5	4.5	6	15	265	300	230	327.5	15	439.5	38	10	41.3	-
132/B14	4.5	6	11	165	200	130	327.5	15	439.5	38	10	41.3	-
160/B5	5.5	10	19	300	350	250	407	20	519	42	12	45.3	8
180/B5	5.5	10	19	300	350	250	407	20	519	48	14	51.8	8

KN473.03

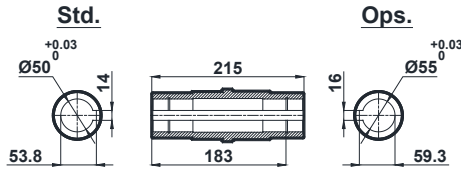
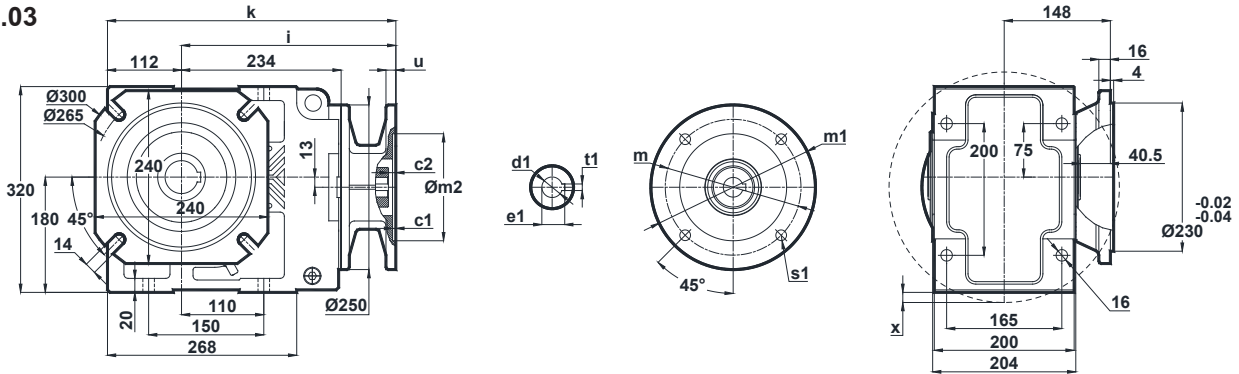

x: Motor Ayak bağlantı yüzeyinin altında ise
x: If Motor is lower than foot mounting plane
x: Wenn der Motor unter der Fußmontageebene ist

Opsiyonel flanş ölçüleri için sayfa 587'ye bakınız.
Please see on page 587 for optional flange dimensions
Siehe Siete 587 für auswählbare Flanschabmessungen

	c1	c2	s1	m	m1	m2	i	u	k	d1	t1	e1	x
80/B5	4	5	12	165	200	130	290.5	12	402.5	19	6	21.8	-
90/B5	4	5	12	165	200	130	290.5	12	402.5	24	8	27.3	-
90/B14	4	5	9	115	140	95	290.5	12	402.5	24	8	27.3	-
100/B5	4.5	9	15	215	250	180	309	15	421	28	8	31.3	-
100/B14	4	9	9	130	160	110	309	15	421	28	8	31.3	-
112/B5	4.5	9	15	215	250	180	309	15	421	28	8	31.3	-
112/B14	4	9	9	130	160	110	309	15	421	28	8	31.3	-
132/B5	4.5	6	15	265	300	230	327.5	15	439.5	38	10	41.3	-
132/B14	4.5	6	11	165	200	130	327.5	15	439.5	38	10	41.3	-
160/B5	5.5	10	19	300	350	250	407	20	519	42	12	45.3	8
180/B5	5.5	10	19	300	350	250	407	20	519	48	14	51.8	8

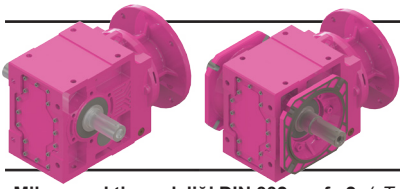

Ölçü Sayfaları Dimension Pages Abmessungsseiten

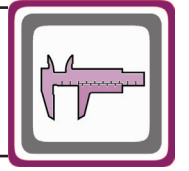

-Mil ucu çektirme deliği DIN 332 sayfa 2 / Tapped center hole to DIN 332, sheet 2 / Zentrierung mit Gewinde DIN 332, Blatt 2

KN473.04

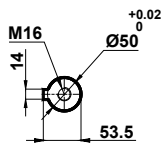
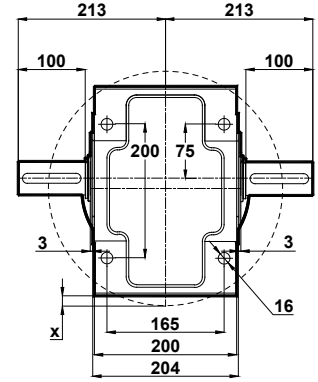
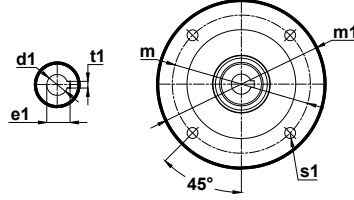
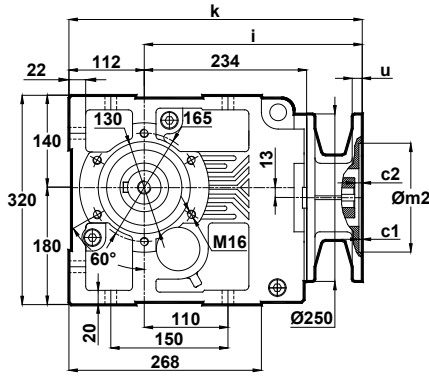

x: Motor Ayak bağlantı yüzeyinin altında ise
x: If Motor is lower than foot mounting plane
x: Wenn der Motor unter der Fußmontageebene ist

	c1	c2	s1	m	m1	m2	i	u	k	d1	t1	e1	x
80/B5	4	5	12	165	200	130	290.5	12	402.5	19	6	21.8	-
90/B5 90/B14	4	5	12	165 115	200 140	130 95	290.5	12	402.5	24	8	27.3	-
100/B5 100/B14	4.5 4	9	15 9	215 130	250 160	180 110	309	15	421	28	8	31.3	-
112/B5 112/B14	4.5 4	9	15 9	215 130	250 160	180 110	309	15	421	28	8	31.3	-
132/B5 132/B14	4.5	6	15 11	265 165	300 200	230 130	327.5	15	439.5	38	10	41.3	-
160/B5	5.5	10	19	300	350	250	407	20	519	42	12	45.3	8
180/B5	5.5	10	19	300	350	250	407	20	519	48	14	51.8	8

KN473.05

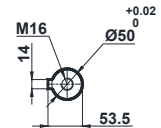
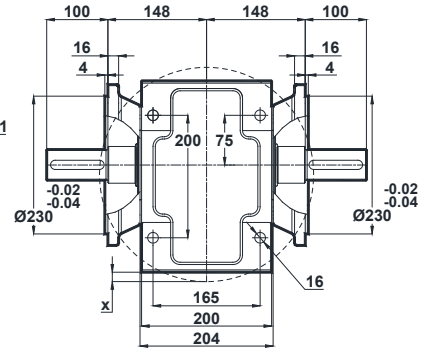
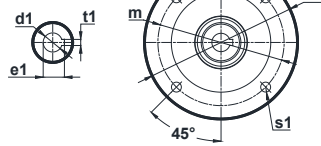
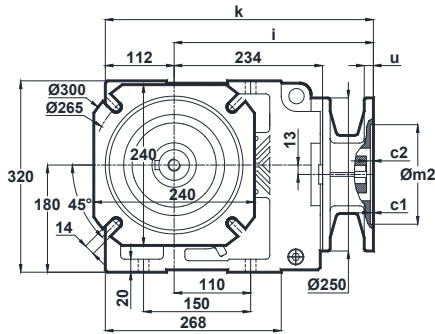

x: Motor Ayak bağlantı yüzeyinin altında ise
x: If Motor is lower than foot mounting plane
x: Wenn der Motor unter der Fußmontageebene ist

Opsiyonel flanş ölçüleri için sayfa 587'ye bakınız.
Please see on page 587 for optional flange dimensions
Siehe Seite 587 für auswählbare Flanschabmessungen

	c1	c2	s1	m	m1	m2	i	u	k	d1	t1	e1	x
80/B5	4	5	12	165	200	130	290.5	12	402.5	19	6	21.8	-
90/B5 90/B14	4	5	12	165 115	200 140	130 95	290.5	12	402.5	24	8	27.3	-
100/B5 100/B14	4.5 4	9	15 9	215 130	250 160	180 110	309	15	421	28	8	31.3	-
112/B5 112/B14	4.5 4	9	15 9	215 130	250 160	180 110	309	15	421	28	8	31.3	-
132/B5 132/B14	4.5	6	15 11	265 165	300 200	230 130	327.5	15	439.5	38	10	41.3	-
160/B5	5.5	10	19	300	350	250	407	20	519	42	12	45.3	8
180/B5	5.5	10	19	300	350	250	407	20	519	48	14	51.8	8

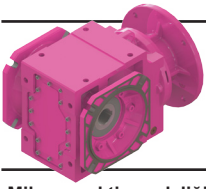

Ölçü Sayfaları Dimension Pages Abmessungsseiten

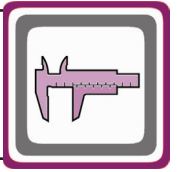

-Mil ucu çektirme deliği DIN 332 sayfa 2 / Tapped center hole to DIN 332, sheet 2 / Zentrierung mit Gewinde DIN 332, Blatt 2

KN473.08

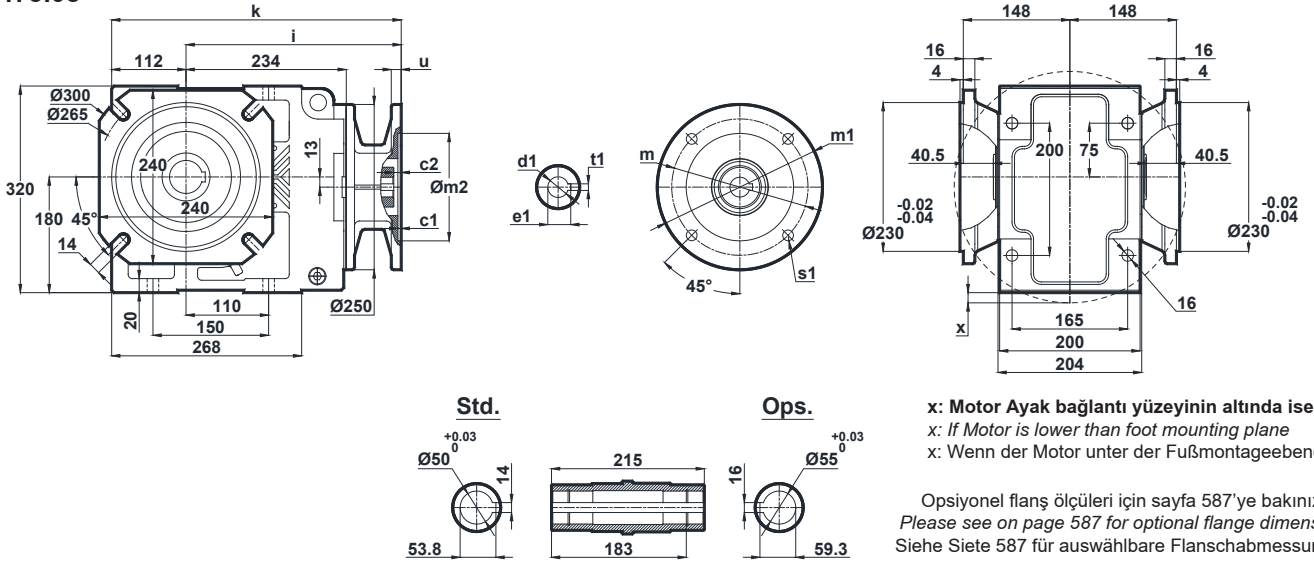

	c1	c2	s1	m	m1	m2	i	u	k	d1	t1	e1	x
80/B5	4	5	12	165	200	130	290.5	12	402.5	19	6	21.8	-
90/B5	4	5	12	165	200	130	290.5	12	402.5	24	8	27.3	-
90/B14	4	5	9	115	140	95	290.5	12	402.5	24	8	27.3	-
100/B5	4.5	9	15	215	250	180	309	15	421	28	8	31.3	-
100/B14	4	9	9	130	160	110	309	15	421	28	8	31.3	-
112/B5	4.5	9	15	215	250	180	309	15	421	28	8	31.3	-
112/B14	4	9	9	130	160	110	309	15	421	28	8	31.3	-
132/B5	4.5	6	15	265	300	230	327.5	15	439.5	38	10	41.3	-
132/B14	4.5	6	11	165	200	130	327.5	15	439.5	38	10	41.3	-
160/B5	5.5	10	19	300	350	250	407	20	519	42	12	45.3	8
180/B5	5.5	10	19	300	350	250	407	20	519	48	14	51.8	8

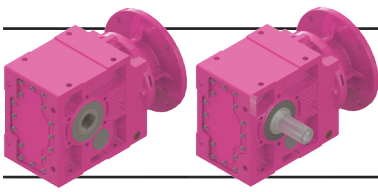

Ölçü Sayfaları

Dimension Pages

Abmessungsseiten

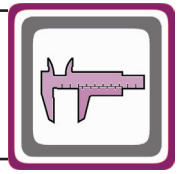

-Mil ucu çekirme deliği DIN 332 sayfa 2 / Tapped center hole to DIN 332, sheet 2 / Zentrierung mit Gewinde DIN 332, Blatt 2

KN474.00

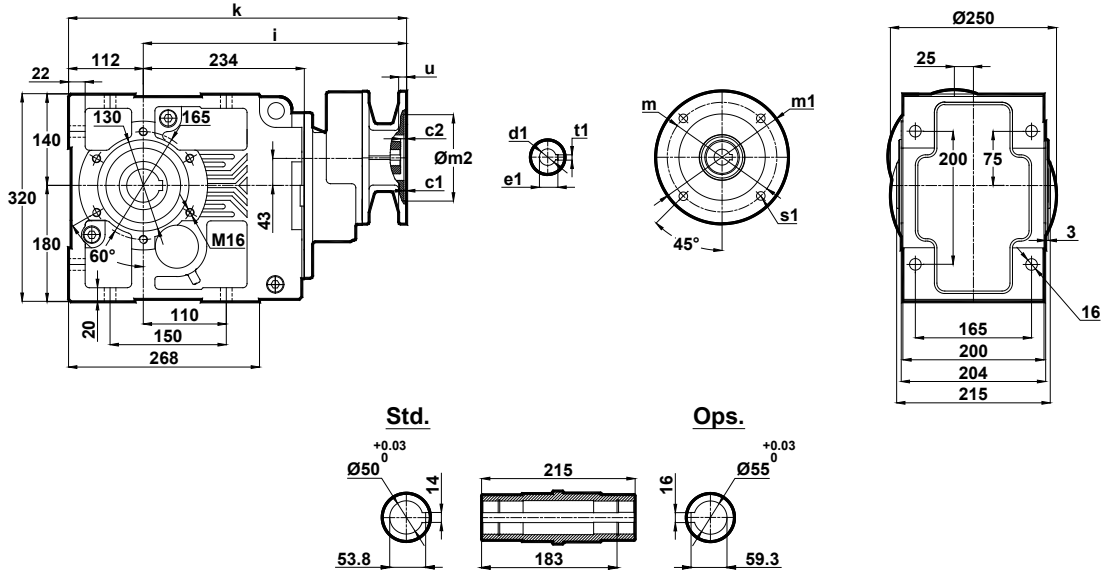

	c1	c2	s1	m	m1	m2	i	u	k	d1	t1	e1
71/B5	4	9	11	130	160	110	388.5	12	500.5	14	5	16.3
80/B5 80/B14	4	9	12 7	165 100	200 120	130 80	388.5	12	500.5	19	6	21.8

KN474.01

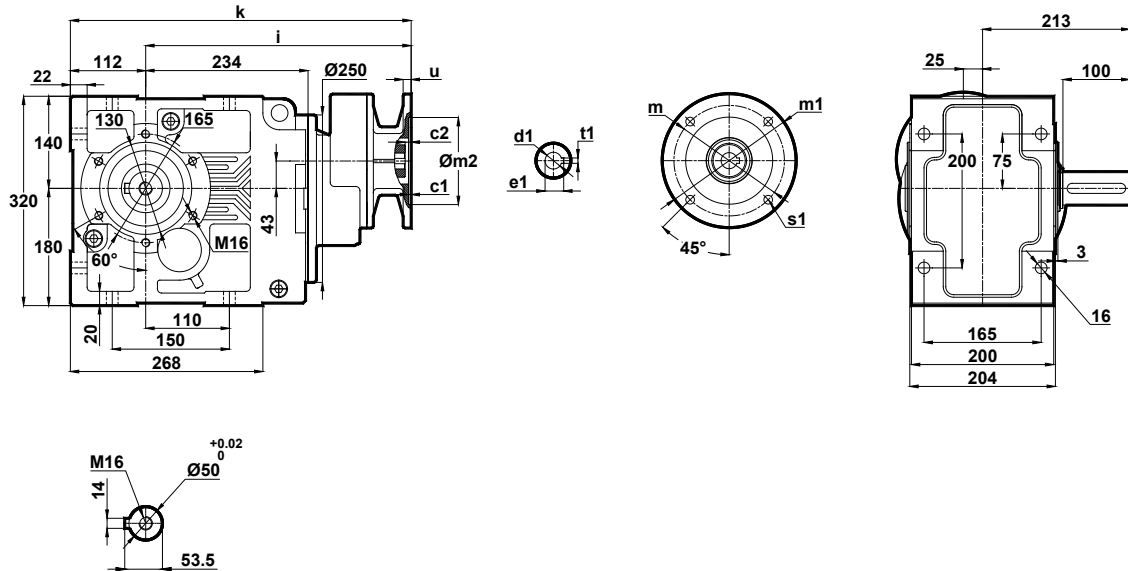

	c1	c2	s1	m	m1	m2	i	u	k	d1	t1	e1
71/B5	4	9	11	130	160	110	388.5	12	500.5	14	5	16.3
80/B5 80/B14	4	9	12 7	165 100	200 120	130 80	388.5	12	500.5	19	6	21.8

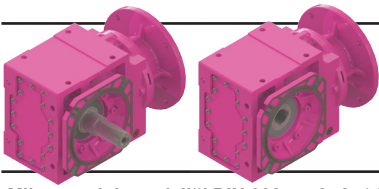

Ölçü Sayfaları

Dimension Pages

Abmessungsseiten

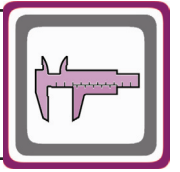

-Mil ucu çekirme deliği DIN 332 sayfa 2 / Tapped center hole to DIN 332, sheet 2 / Zentrierung mit Gewinde DIN 332, Blatt 2

KN474.02

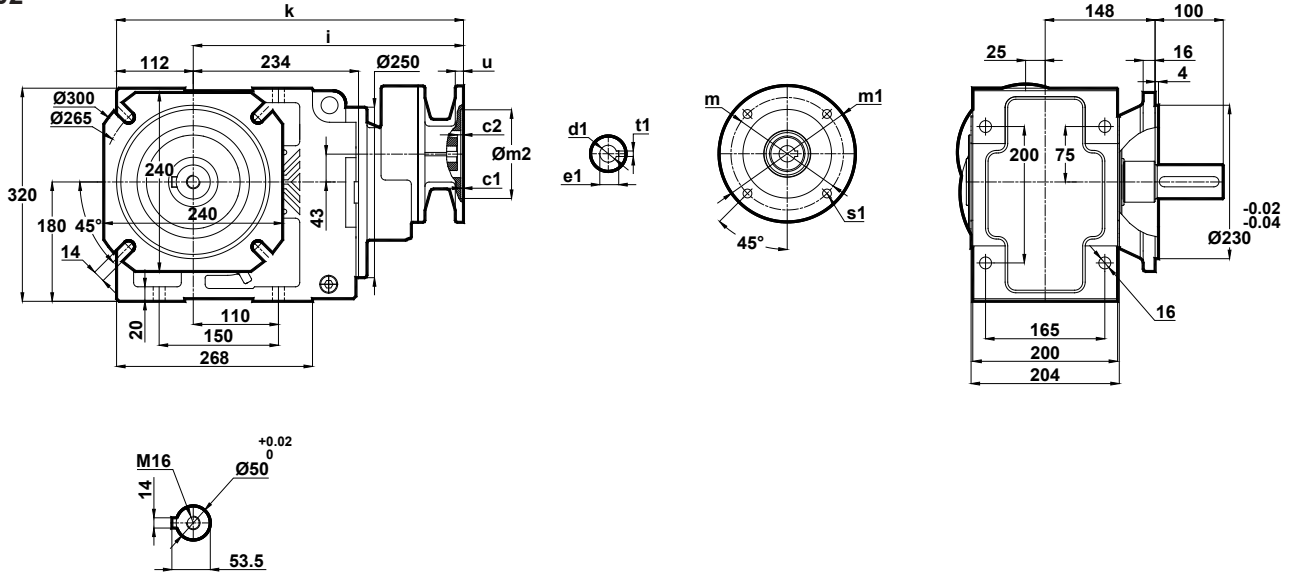

Opsiyonel flanş ölçüleri için sayfa 587'ye bakınız.
Please see on page 587 for optional flange dimensions
Siehe Seite 587 für auswählbare Flanschabmessungen

	c1	c2	s1	m	m1	m2	i	u	k	d1	t1	e1
71/B5	4	9	11	130	160	110	388.5	12	500.5	14	5	16.3
80/B5 80/B14	4	9	12 7	165 100	200 120	130 80	388.5	12	500.5	19	6	21.8

KN474.03

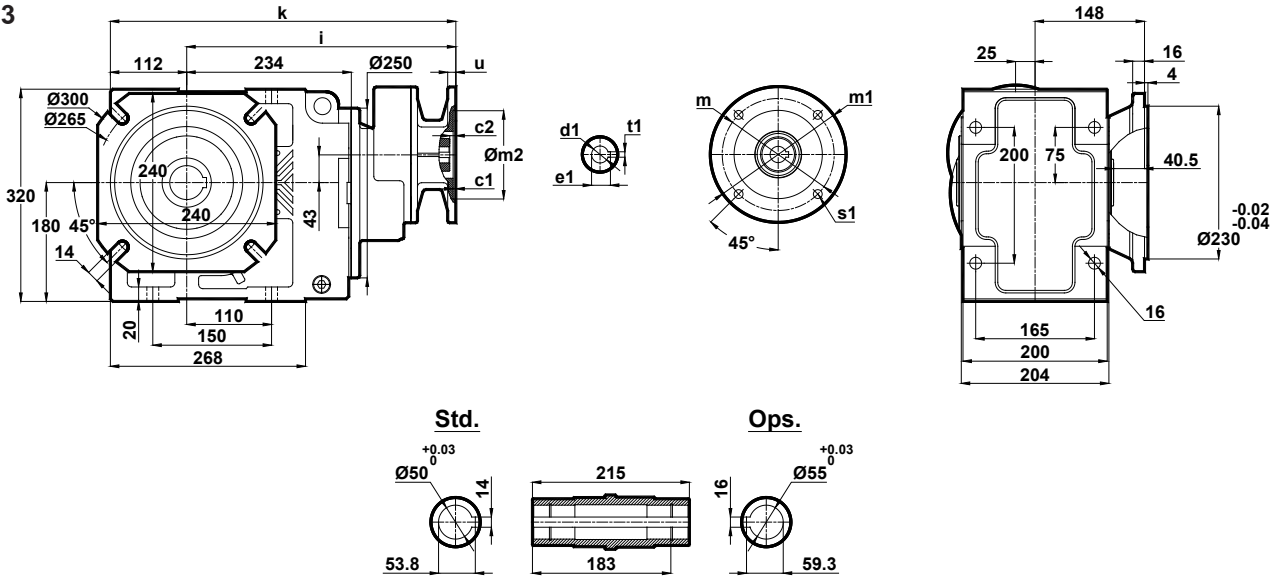

Opsiyonel flanş ölçüleri için sayfa 587'ye bakınız.
Please see on page 587 for optional flange dimensions
Siehe Seite 587 für auswählbare Flanschabmessungen

	c1	c2	s1	m	m1	m2	i	u	k	d1	t1	e1
71/B5	4	9	11	130	160	110	388.5	12	500.5	14	5	16.3
80/B5 80/B14	4	9	12 7	165 100	200 120	130 80	388.5	12	500.5	19	6	21.8

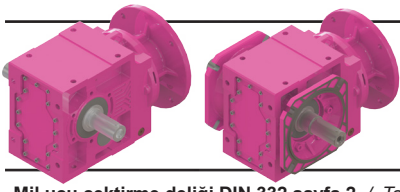

Ölçü Sayfaları

Dimension Pages

Abmessungsseiten

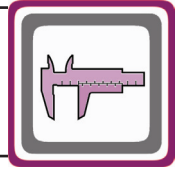

-Mil ucu çekirme deliği DIN 332 sayfa 2 / Tapped center hole to DIN 332, sheet 2 / Zentrierung mit Gewinde DIN 332, Blatt 2

KN474.04

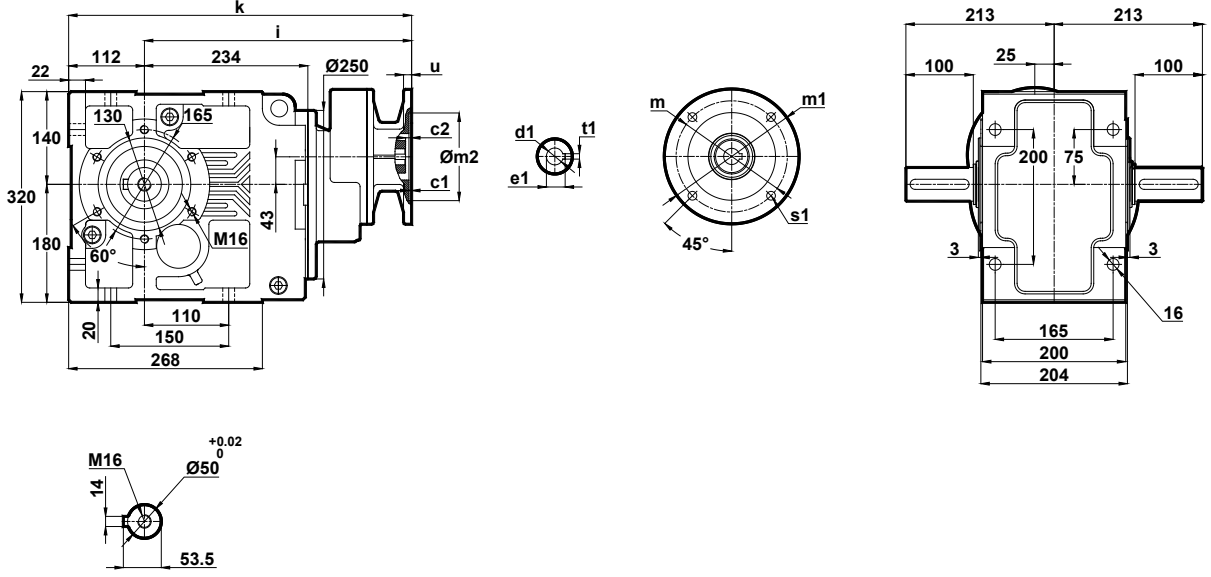

	c1	c2	s1	m	m1	m2	i	u	k	d1	t1	e1
71/B5	4	9	11	130	160	110	388.5	12	500.5	14	5	16.3
80/B5 80/B14	4	9	12 7	165 100	200 120	130 80	388.5	12	500.5	19	6	21.8

KN474.05

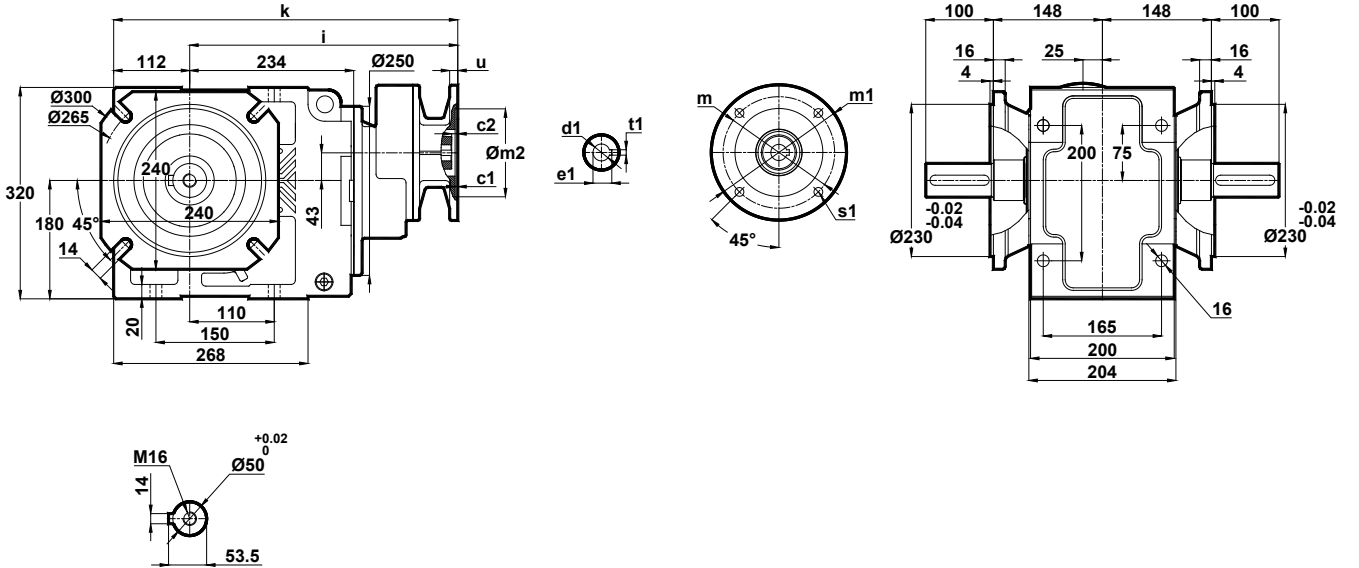

Opsiyonel flanş ölçüleri için sayfa 587'ye bakınız.
Please see on page 587 for optional flange dimensions
Siehe Seite 587 für auswählbare Flanschabmessungen

	c1	c2	s1	m	m1	m2	i	u	k	d1	t1	e1
71/B5	4	9	11	130	160	110	388.5	12	500.5	14	5	16.3
80/B5 80/B14	4	9	12 7	165 100	200 120	130 80	388.5	12	500.5	19	6	21.8

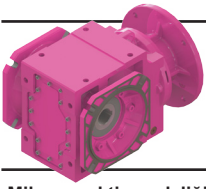

Ölçü Sayfaları Dimension Pages Abmessungsseiten

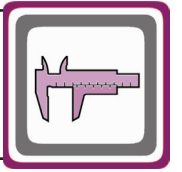

-Mil ucu çekirme deliği DIN 332 sayfa 2 / Tapped center hole to DIN 332, sheet 2 / Zentrierung mit Gewinde DIN 332, Blatt 2

KN474.08

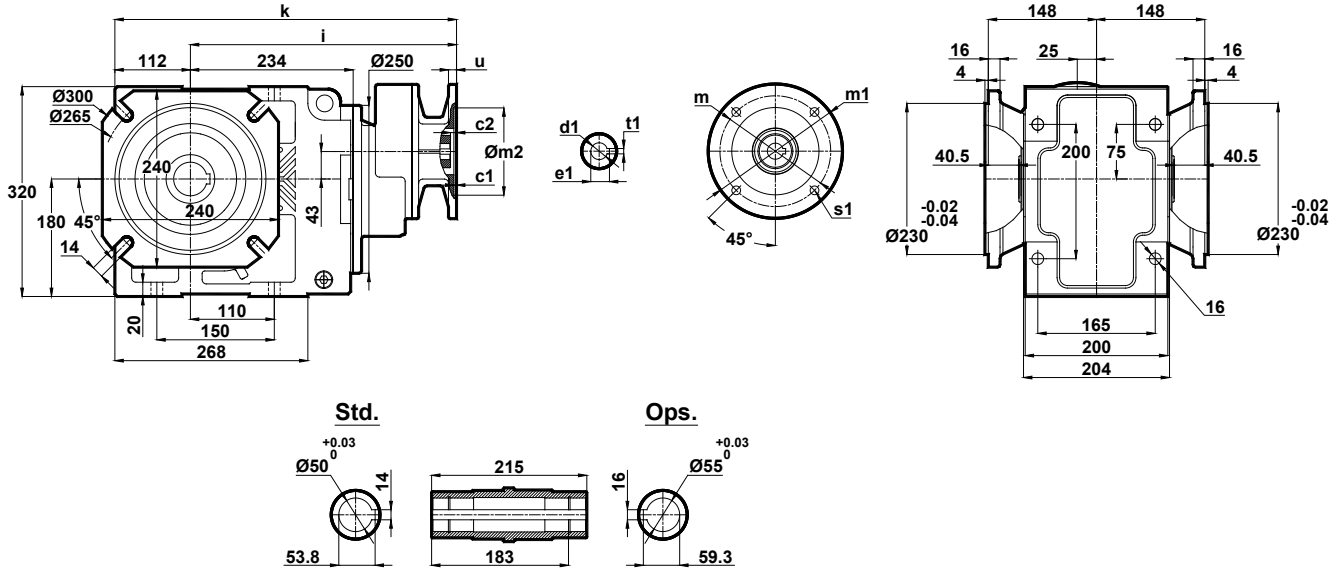

Opsiyonel flanş ölçüleri için sayfa 587'ye bakınız.
Please see on page 587 for optional flange dimensions
Siehe Seite 587 für auswählbare Flanschabmessungen

	c1	c2	s1	m	m1	m2	i	u	k	d1	t1	e1
71/B5	4	9	11	130	160	110	388.5	12	500.5	14	5	16.3
80/B5 80/B14	4	9	12 7	165 100	200 120	130 80	388.5	12	500.5	19	6	21.8

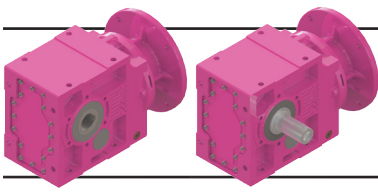

Ölçü Sayfaları

Dimension Pages

Abmessungsseiten

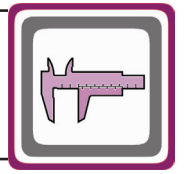

-Mil ucu çekirme deliği DIN 332 sayfa 2 / Tapped center hole to DIN 332, sheet 2 / Zentrierung mit Gewinde DIN 332, Blatt 2

KN475.00
KN476.00

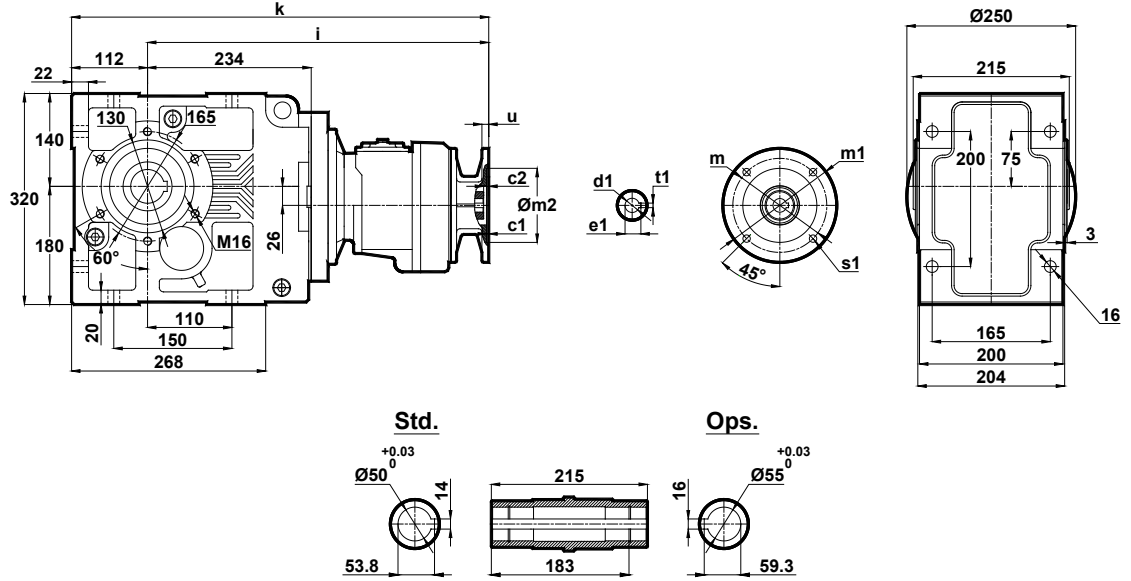

	c1	c2	s1	m	m1	m2	i	u	k	d1	t1	e1
63/B5	3.5	5	9	115	140	95	516.5	12	628.5	11	4	12.8
71/B5	4	8.5	11	130	160	110	487.5	12	599.5	14	5	16.3
71/B14	3		7	85	105	70		10				

KN475.01
KN476.01

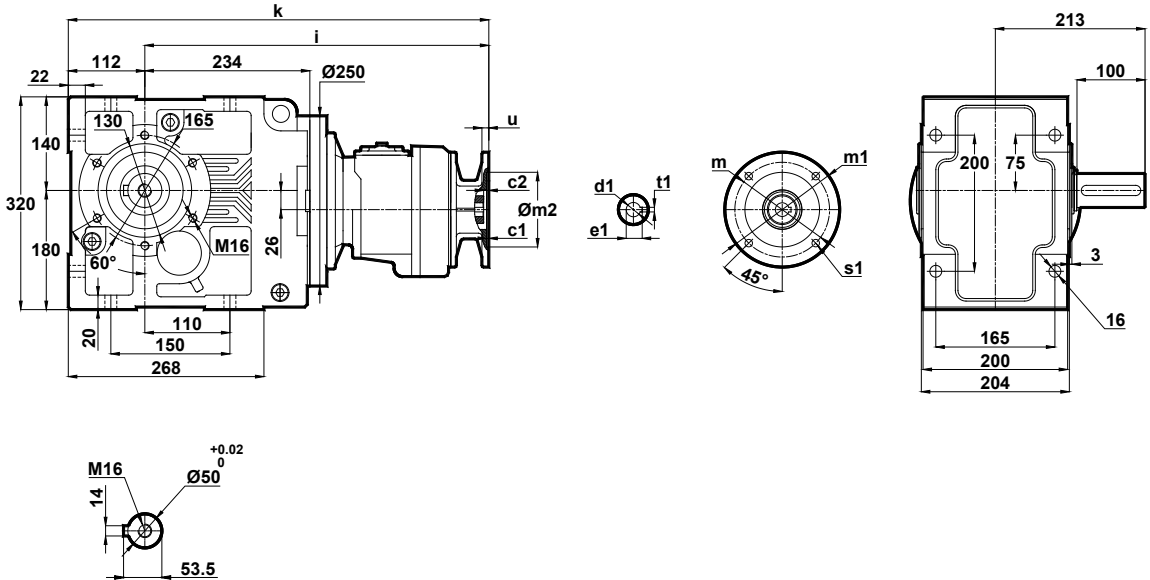

	c1	c2	s1	m	m1	m2	i	u	k	d1	t1	e1
63/B5	3.5	5	9	115	140	95	516.5	12	628.5	11	4	12.8
71/B5	4	8.5	11	130	160	110	487.5	12	599.5	14	5	16.3
71/B14	3		7	85	105	70		10				

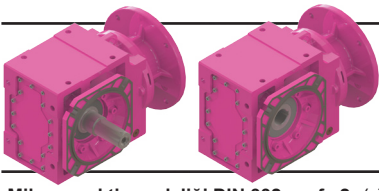

Ölçü Sayfaları Dimension Pages Abmessungenseiten

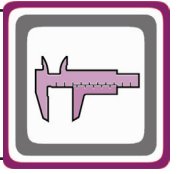

-Mil ucu çekirme deliği DIN 332 sayfa 2 / Tapped center hole to DIN 332, sheet 2 / Zentrierung mit Gewinde DIN 332, Blatt 2

KN475.02
KN476.02

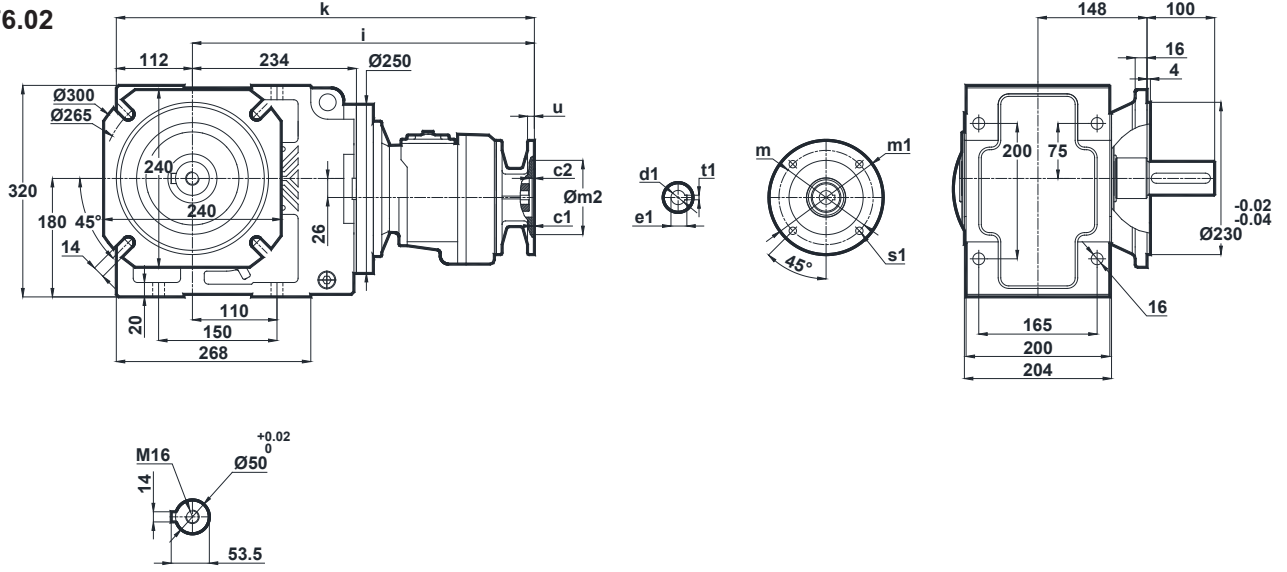

Opsiyonel flanş ölçüleri için sayfa 587'ye bakınız.
Please see on page 587 for optional flange dimensions
Siehe Seite 587 für auswählbare Flanschabmessungen

	c1	c2	s1	m	m1	m2	i	u	k	d1	t1	e1
63/B5	3.5	5	9	115	140	95	516.5	12	628.5	11	4	12.8
71/B5 71/B14	4 3	8.5	11 7	130 85	160 105	110 70	487.5	12 10	599.5	14	5	16.3

KN475.03
KN476.03

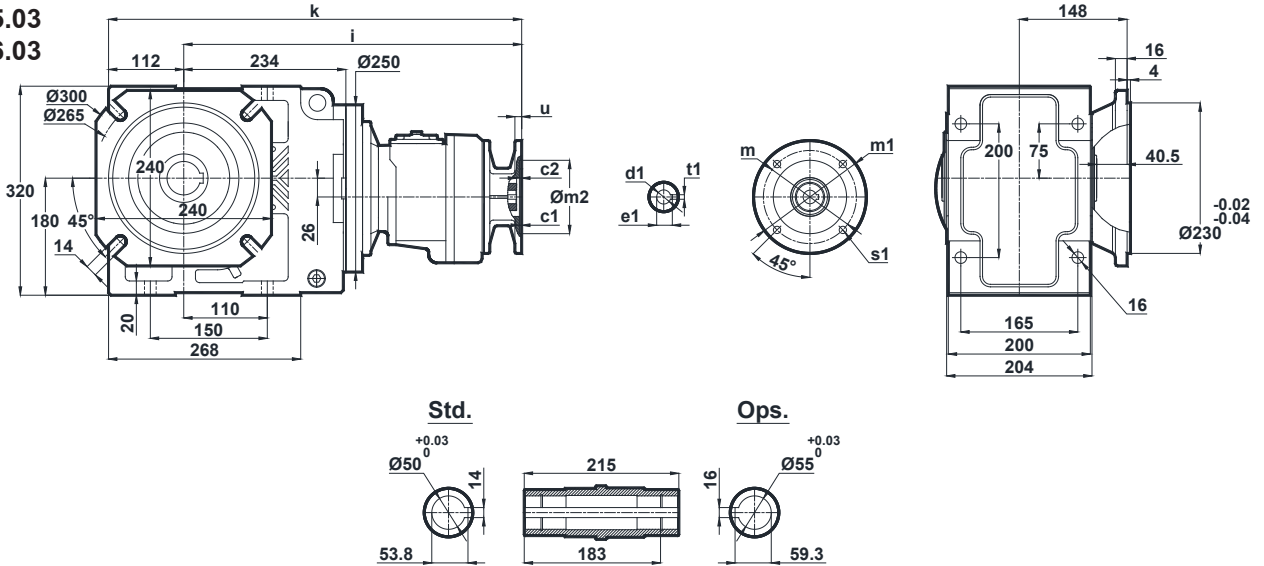

Opsiyonel flanş ölçüleri için sayfa 587'ye bakınız.
Please see on page 587 for optional flange dimensions
Siehe Seite 587 für auswählbare Flanschabmessungen

	c1	c2	s1	m	m1	m2	i	u	k	d1	t1	e1
63/B5	3.5	5	9	115	140	95	516.5	12	628.5	11	4	12.8
71/B5 71/B14	4 3	8.5	11 7	130 85	160 105	110 70	487.5	12 10	599.5	14	5	16.3

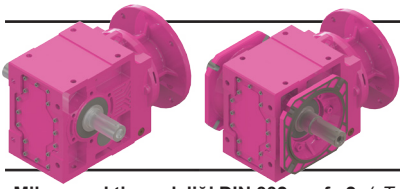

Ölçü Sayfaları

Dimension Pages

Abmessungsseiten

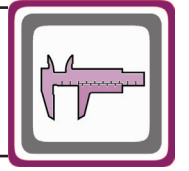

-Mil ucu çektirme deliği DIN 332 sayfa 2 / Tapped center hole to DIN 332, sheet 2 / Zentrierung mit Gewinde DIN 332, Blatt 2

KN475.04
KN476.04

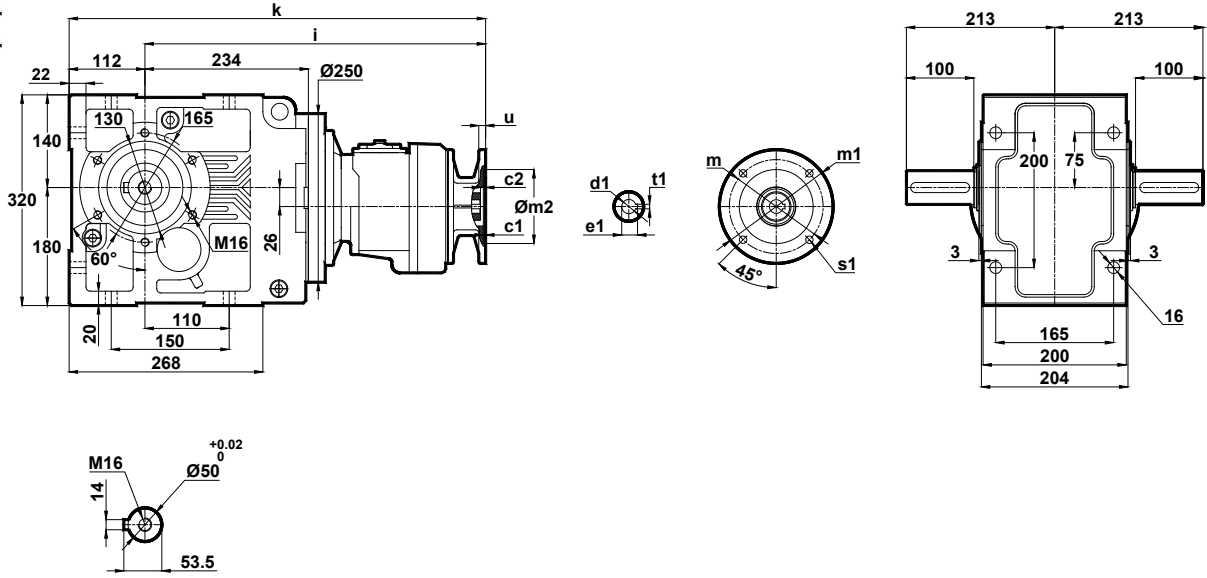

	c1	c2	s1	m	m1	m2	i	u	k	d1	t1	e1
63/B5	3.5	5	9	115	140	95	516.5	12	628.5	11	4	12.8
71/B5	4	8.5	11	130	160	110	487.5	12	599.5	14	5	16.3
71/B14	3		7	85	105	70		10				

KN475.05
KN476.05

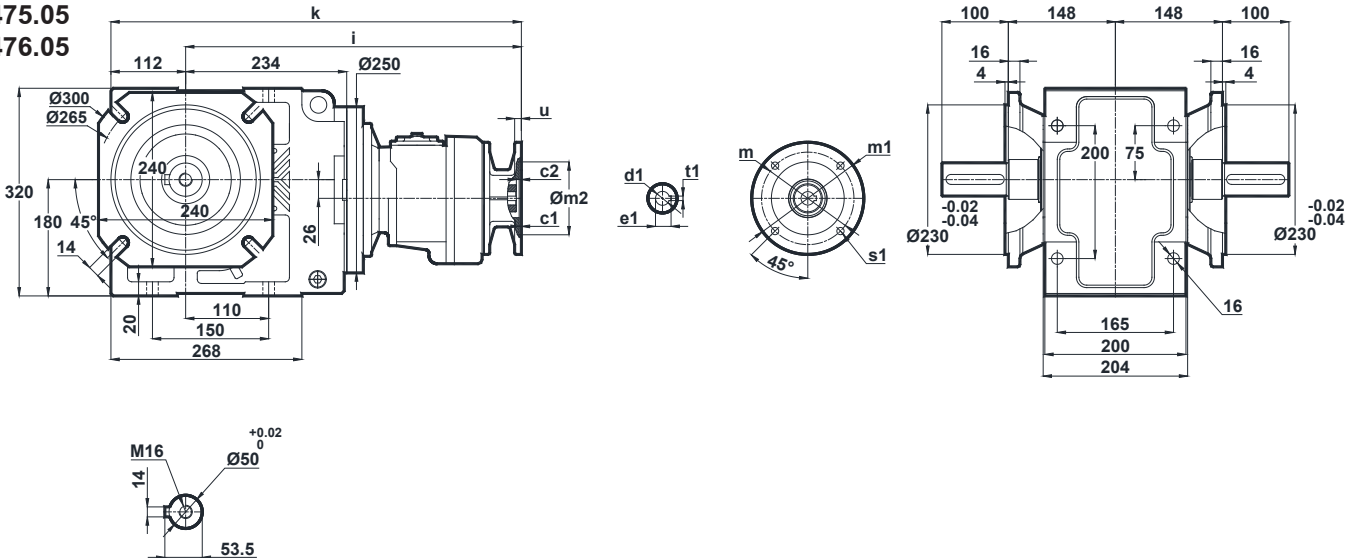

	c1	c2	s1	m	m1	m2	i	u	k	d1	t1	e1
63/B5	3.5	5	9	115	140	95	516.5	12	628.5	11	4	12.8
71/B5	4	8.5	11	130	160	110	487.5	12	599.5	14	5	16.3
71/B14	3		7	85	105	70		10				

Opsiyonel flanş ölçüleri için sayfa 587'ye bakınız.
Please see on page 587 for optional flange dimensions
Siehe Seite 587 für auswählbare Flanschabmessungen

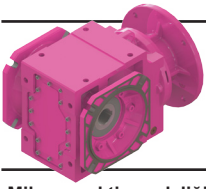

Ölçü Sayfaları Dimension Pages Abmessungsseiten

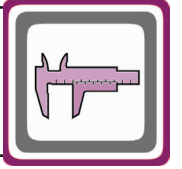

-Mil ucu çekirme deliği DIN 332 sayfa 2 / Tapped center hole to DIN 332, sheet 2 / Zentrierung mit Gewinde DIN 332, Blatt 2

KN475.08
KN476.08

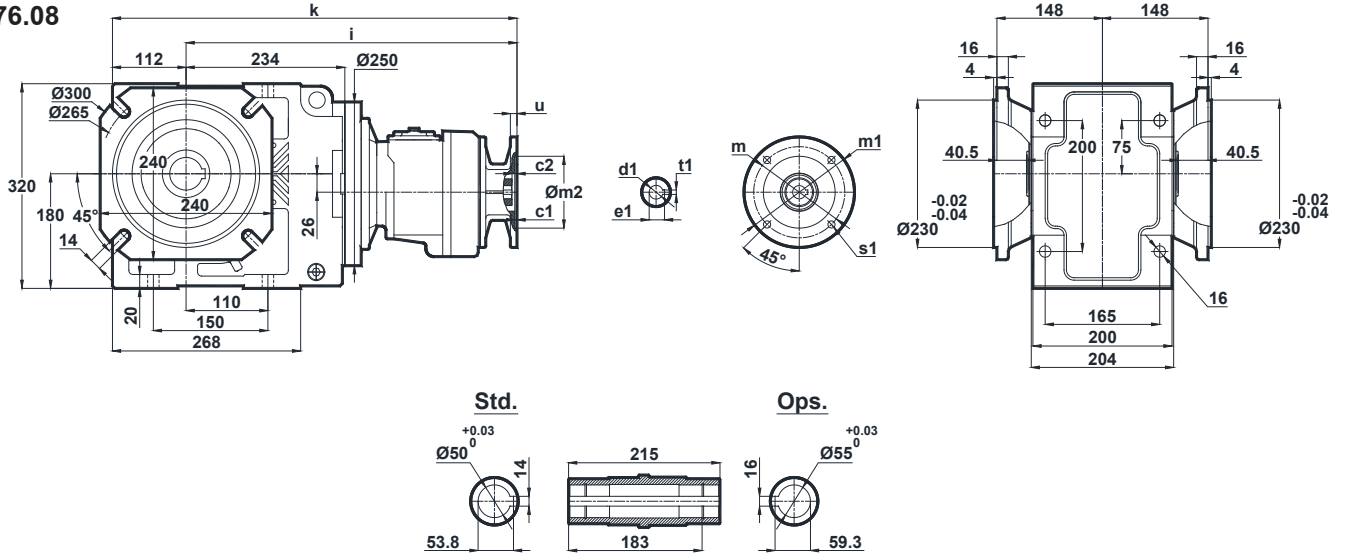

Opsiyonel flanş ölçüleri için sayfa 587'ye bakınız.
Please see on page 587 for optional flange dimensions
Siehe Seite 587 für auswählbare Flanschabmessungen

	c1	c2	s1	m	m1	m2	i	u	k	d1	t1	e1
63/B5	3.5	5	9	115	140	95	516.5	12	628.5	11	4	12.8
71/B5 71/B14	4 3	8.5	11 7	130 85	160 105	110 70	487.5	12 10	599.5	14	5	16.3

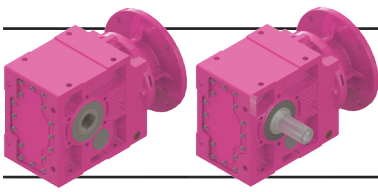

Ölçü Sayfaları

Dimension Pages

Abmessungsseiten

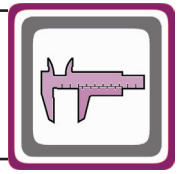

-Mil ucu çekirme deliği DIN 332 sayfa 2 / Tapped center hole to DIN 332, sheet 2 / Zentrierung mit Gewinde DIN 332, Blatt 2

KN573.00

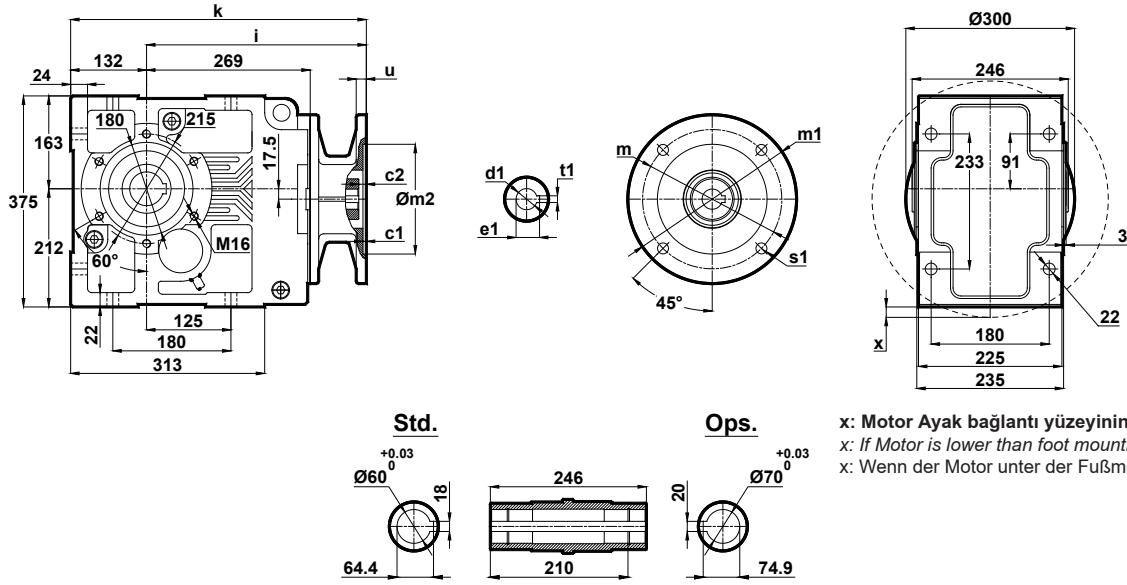

x: Motor Ayak bağlantı yüzeyinin altında ise
 x: If Motor is lower than foot mounting plane
 x: Wenn der Motor unter der Fußmontageebene ist

	c1	c2	s1	m	m1	m2	i	u	k	d1	t1	e1	x
100/B5	4.5	9	15	215	250	180	341.5	15	473.5	28	8	31.3	-
112/B5	4.5	9	15	215	250	180	341.5	15	473.5	28	8	31.3	-
132/B5 132/B14	4.5	9	15 11	265 165	300 200	230 130	362.5	15	494.5	38	10	41.3	-
160/B5	5.5	10	19	300	350	250	438	18	570	42	12	45.3	-
180/B5	5.5	10	19	300	350	250	438	18	570	48	14	51.8	-

KN573.01

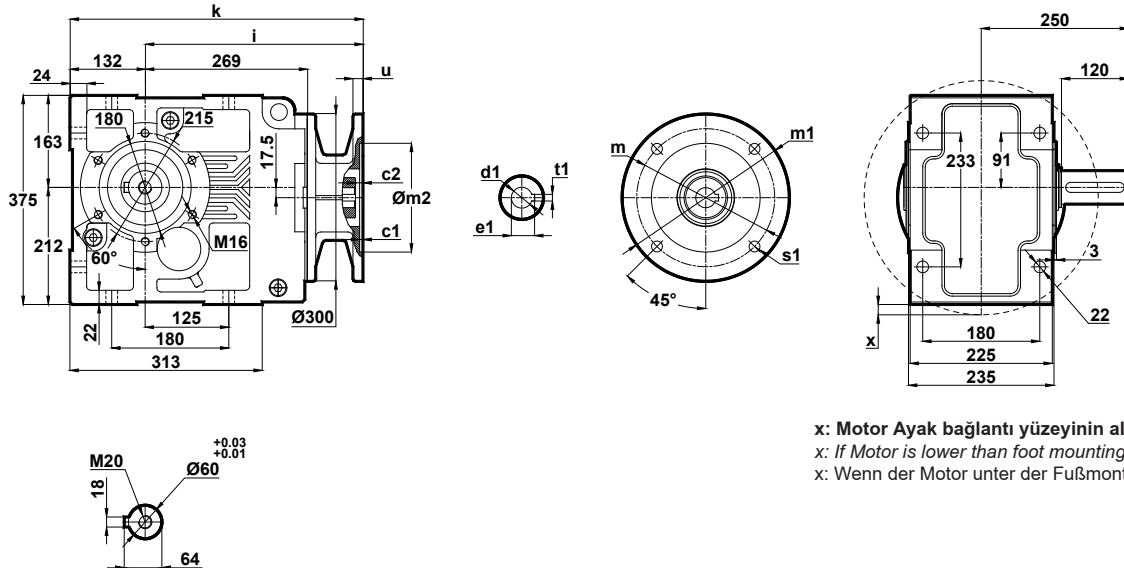

x: Motor Ayak bağlantı yüzeyinin altında ise
 x: If Motor is lower than foot mounting plane
 x: Wenn der Motor unter der Fußmontageebene ist

	c1	c2	s1	m	m1	m2	i	u	k	d1	t1	e1	x
100/B5	4.5	9	15	215	250	180	341.5	15	473.5	28	8	31.3	-
112/B5	4.5	9	15	215	250	180	341.5	15	473.5	28	8	31.3	-
132/B5 132/B14	4.5	9	15 11	265 165	300 200	230 130	362.5	15	494.5	38	10	41.3	-
160/B5	5.5	10	19	300	350	250	438	18	570	42	12	45.3	-
180/B5	5.5	10	19	300	350	250	438	18	570	48	14	51.8	-

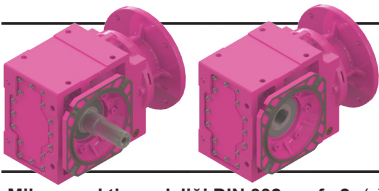

Ölçü Sayfaları

Dimension Pages

Abmessungsseiten

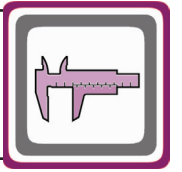

-Mil ucu çektirme deliği DIN 332 sayfa 2 / Tapped center hole to DIN 332, sheet 2 / Zentrierung mit Gewinde DIN 332, Blatt 2

KN573.02

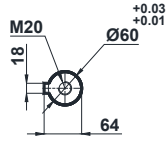
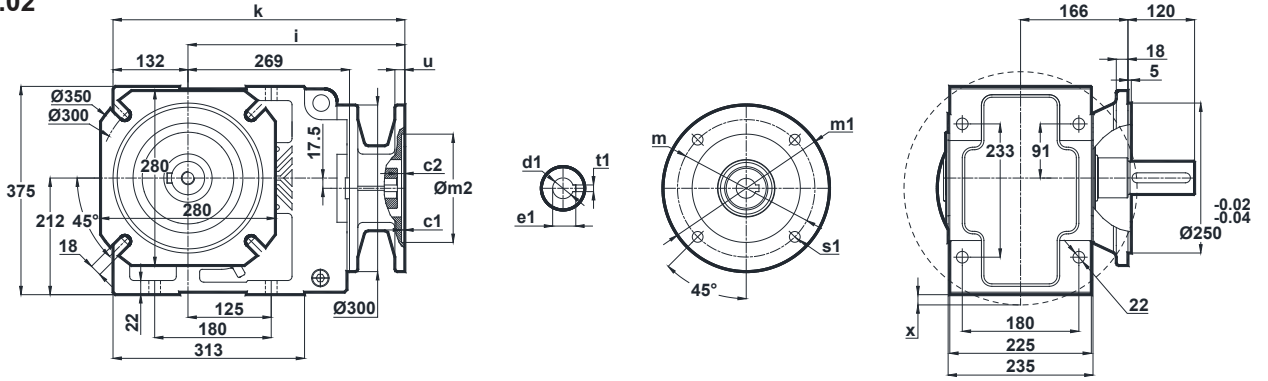

x: Motor Ayak bağlantı yüzeyinin altında ise
x: If Motor is lower than foot mounting plane
x: Wenn der Motor unter der Fußmontageebene ist

Opsiyonel flanş ölçüleri için sayfa 587'ye bakınız.
Please see on page 587 for optional flange dimensions
Siehe Seite 587 für auswählbare Flanschabmessungen

	c1	c2	s1	m	m1	m2	i	u	k	d1	t1	e1	x
100/B5	4.5	9	15	215	250	180	341.5	15	473.5	28	8	31.3	-
112/B5	4.5	9	15	215	250	180	341.5	15	473.5	28	8	31.3	-
132/B5 132/B14	4.5	9	15 11	265 165	300 200	230 130	362.5	15	494.5	38	10	41.3	-
160/B5	5.5	10	19	300	350	250	438	18	570	42	12	45.3	-
180/B5	5.5	10	19	300	350	250	438	18	570	48	14	51.8	-

KN573.03

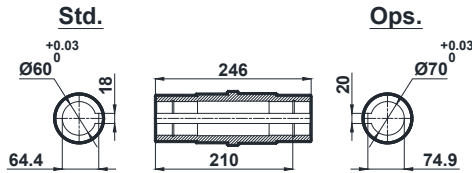
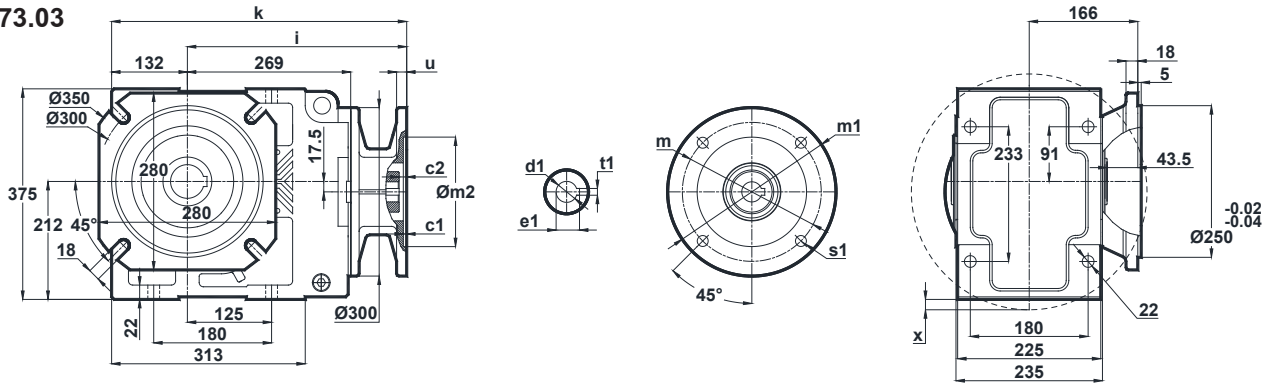

x: Motor Ayak bağlantı yüzeyinin altında ise
x: If Motor is lower than foot mounting plane
x: Wenn der Motor unter der Fußmontageebene ist

Opsiyonel flanş ölçüleri için sayfa 587'ye bakınız.
Please see on page 587 for optional flange dimensions
Siehe Seite 587 für auswählbare Flanschabmessungen

	c1	c2	s1	m	m1	m2	i	u	k	d1	t1	e1	x
100/B5	4.5	9	15	215	250	180	341.5	15	473.5	28	8	31.3	-
112/B5	4.5	9	15	215	250	180	341.5	15	473.5	28	8	31.3	-
132/B5 132/B14	4.5	9	15 11	265 165	300 200	230 130	362.5	15	494.5	38	10	41.3	-
160/B5	5.5	10	19	300	350	250	438	18	570	42	12	45.3	-
180/B5	5.5	10	19	300	350	250	438	18	570	48	14	51.8	-

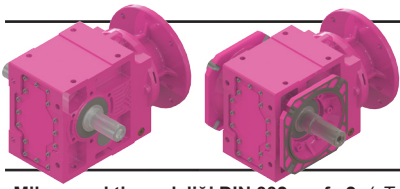

Ölçü Sayfaları Dimension Pages Abmessungsseiten

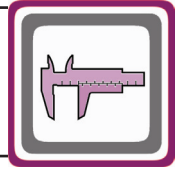

-Mil ucu çektirme deliği DIN 332 sayfa 2 / Tapped center hole to DIN 332, sheet 2 / Zentrierung mit Gewinde DIN 332, Blatt 2

KN573.04

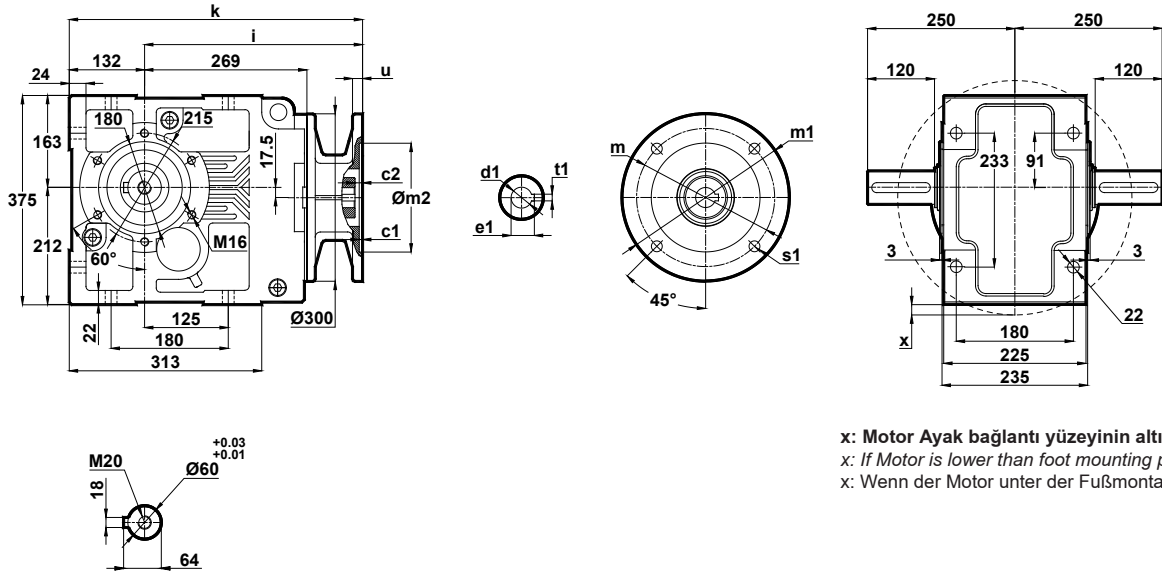

x: Motor Ayak bağlantı yüzeyinin altında ise
x: If Motor is lower than foot mounting plane
x: Wenn der Motor unter der Fußmontageebene ist

	c1	c2	s1	m	m1	m2	i	u	k	d1	t1	e1	x
100/B5	4.5	9	15	215	250	180	341.5	15	473.5	28	8	31.3	-
112/B5	4.5	9	15	215	250	180	341.5	15	473.5	28	8	31.3	-
132/B5 132/B14	4.5	9	15 11	265 165	300 200	230 130	362.5	15	494.5	38	10	41.3	-
160/B5	5.5	10	19	300	350	250	438	18	570	42	12	45.3	-
180/B5	5.5	10	19	300	350	250	438	18	570	48	14	51.8	-

KN573.05

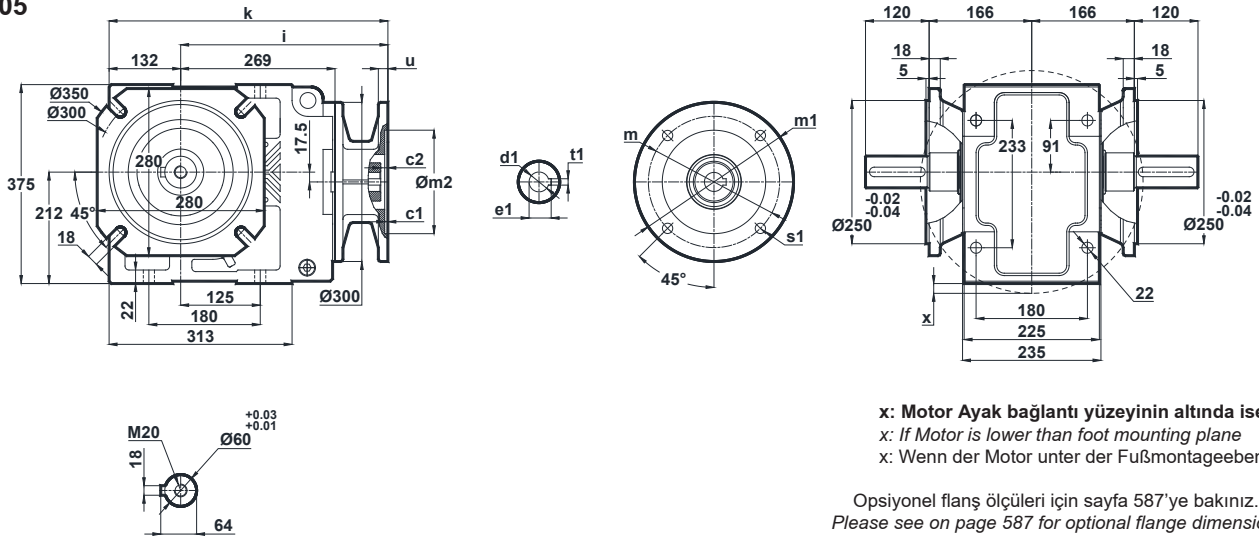

x: Motor Ayak bağlantı yüzeyinin altında ise
x: If Motor is lower than foot mounting plane
x: Wenn der Motor unter der Fußmontageebene ist

Opsiyonel flanş ölçüleri için sayfa 587'ye bakınız.
Please see on page 587 for optional flange dimensions
Siehe Seite 587 für auswählbare Flanschabmessungen

	c1	c2	s1	m	m1	m2	i	u	k	d1	t1	e1	x
100/B5	4.5	9	15	215	250	180	341.5	15	473.5	28	8	31.3	-
112/B5	4.5	9	15	215	250	180	341.5	15	473.5	28	8	31.3	-
132/B5 132/B14	4.5	9	15 11	265 165	300 200	230 130	362.5	15	494.5	38	10	41.3	-
160/B5	5.5	10	19	300	350	250	438	18	570	42	12	45.3	-
180/B5	5.5	10	19	300	350	250	438	18	570	48	14	51.8	-

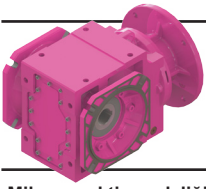

Ölçü Sayfaları Dimension Pages Abmessungsseiten

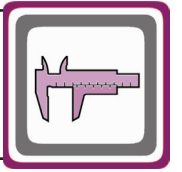

-Mil ucu çektirme deliği DIN 332 sayfa 2 / Tapped center hole to DIN 332, sheet 2 / Zentrierung mit Gewinde DIN 332, Blatt 2

KN573.08

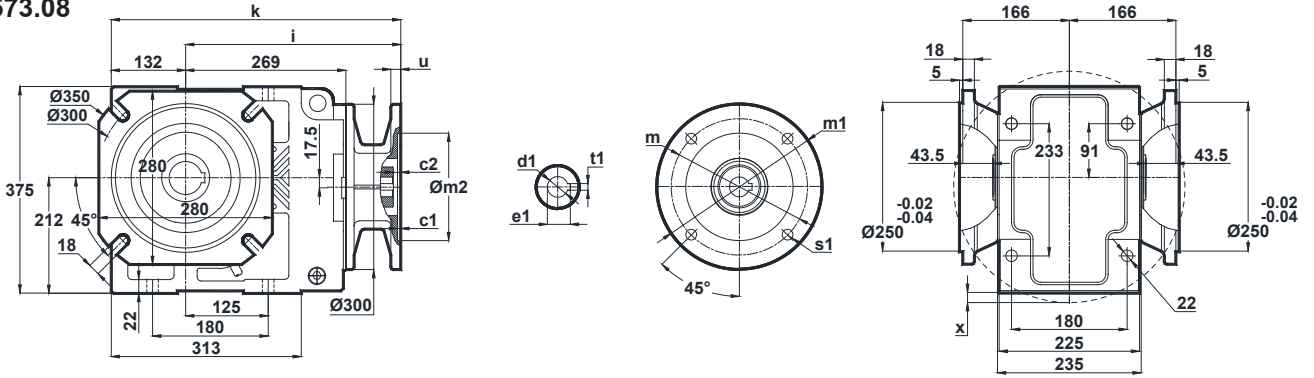

Std.



Ops.

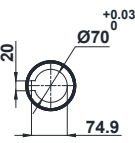

x: Motor Ayak bağlantı yüzeyinin altında ise
x: If Motor is lower than foot mounting plane
x: Wenn der Motor unter der Fußmontageebene ist

Opsiyonel flanş ölçüleri için sayfa 587'ye bakınız.
Please see on page 587 for optional flange dimensions
Siehe Seite 587 für auswählbare Flanschabmessungen

	c1	c2	s1	m	m1	m2	i	u	k	d1	t1	e1	x
100/B5	4.5	9	15	215	250	180	341.5	15	473.5	28	8	31.3	-
112/B5	4.5	9	15	215	250	180	341.5	15	473.5	28	8	31.3	-
132/B5 132/B14	4.5	9	15 11	265 165	300 200	230 130	362.5	15	494.5	38	10	41.3	-
160/B5	5.5	10	19	300	350	250	438	18	570	42	12	45.3	-
180/B5	5.5	10	19	300	350	250	438	18	570	48	14	51.8	-

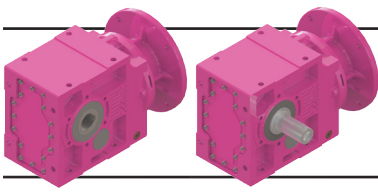

Ölçü Sayfaları

Dimension Pages

Abmessungsseiten

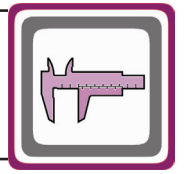

-Mil ucu çekirme deliği DIN 332 sayfa 2 / Tapped center hole to DIN 332, sheet 2 / Zentrierung mit Gewinde DIN 332, Blatt 2

KN574.00

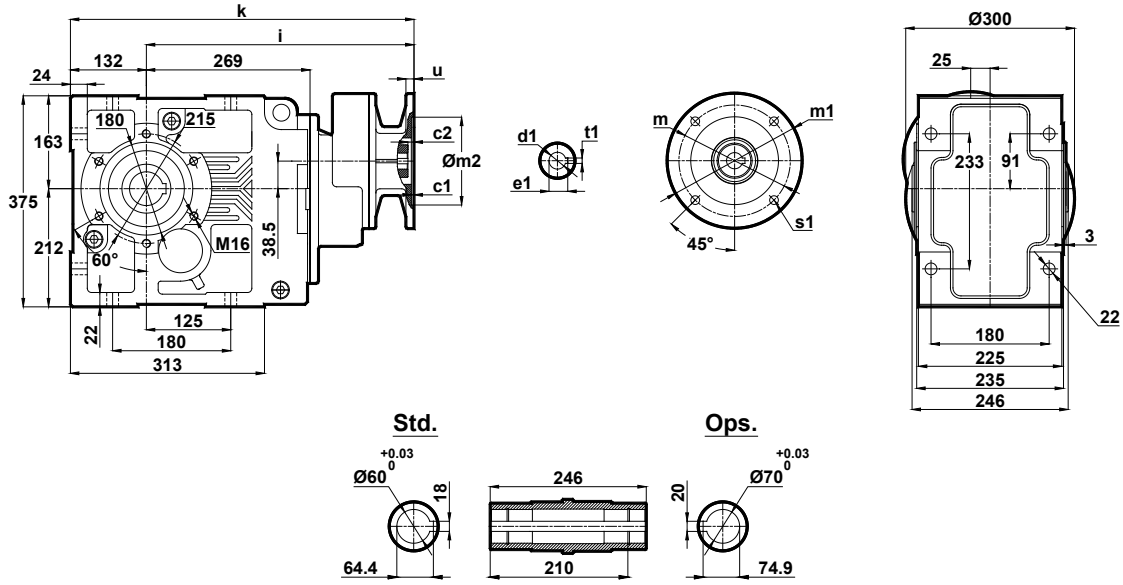

	c1	c2	s1	m	m1	m2	i	u	k	d1	t1	e1
71/B5	4	9	11	130	160	110	421.5	12	553.5	14	5	16.3
80/B5	4	9	12	165	200	130	421.5	12	553.5	19	6	21.8
80/B14	4	9	7	100	120	80	421.5	12	553.5	19	6	21.8
90/B5	4	9	12	165	200	130	421.5	12	553.5	24	8	27.3
90/B14	4	9	9	115	140	95	421.5	12	553.5	24	8	27.3
100/B5	4.5	9	15	215	250	180	438.5	15	570.5	28	8	31.3

KN574.01

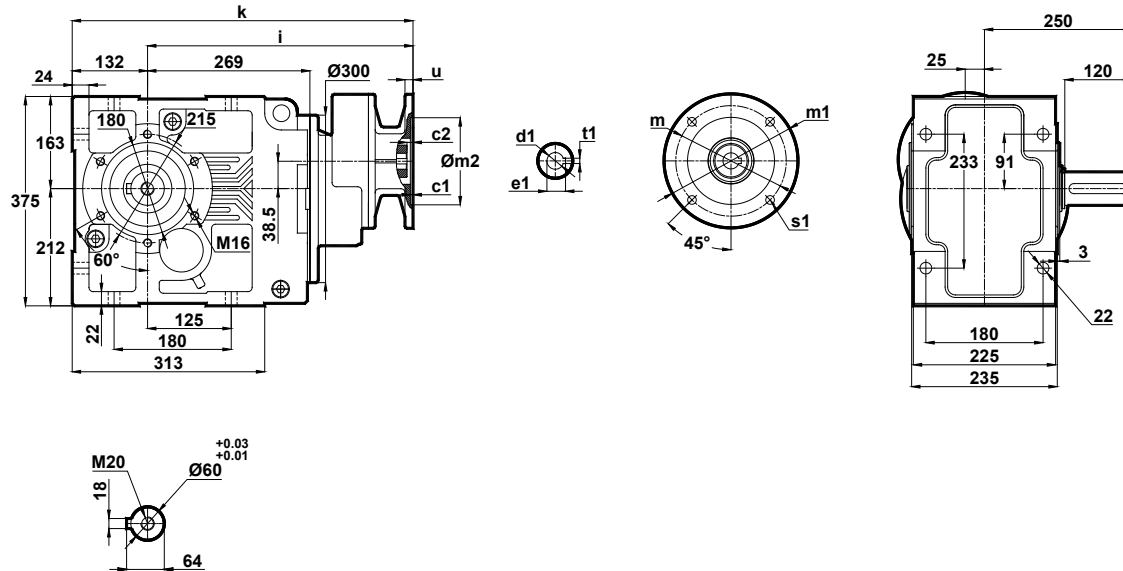

	c1	c2	s1	m	m1	m2	i	u	k	d1	t1	e1
71/B5	4	9	11	130	160	110	421.5	12	553.5	14	5	16.3
80/B5	4	9	12	165	200	130	421.5	12	553.5	19	6	21.8
80/B14	4	9	7	100	120	80	421.5	12	553.5	19	6	21.8
90/B5	4	9	12	165	200	130	421.5	12	553.5	24	8	27.3
90/B14	4	9	9	115	140	95	421.5	12	553.5	24	8	27.3
100/B5	4.5	9	15	215	250	180	438.5	15	570.5	28	8	31.3

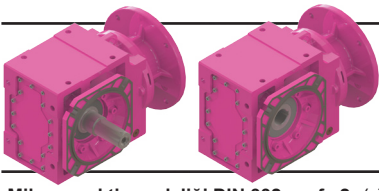

Ölçü Sayfaları

Dimension Pages

Abmessungsseiten

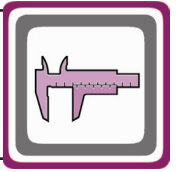

-Mil ucu çektirme deliği DIN 332 sayfa 2 / Tapped center hole to DIN 332, sheet 2 / Zentrierung mit Gewinde DIN 332, Blatt 2

KN574.02

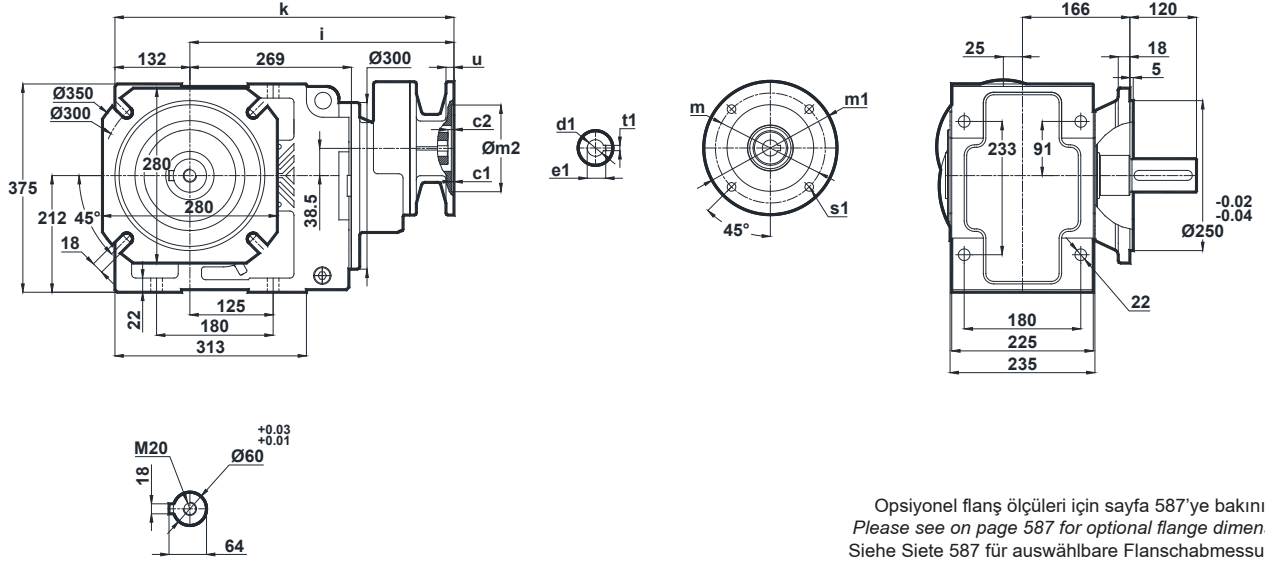

	c1	c2	s1	m	m1	m2	i	u	k	d1	t1	e1
71/B5	4	9	11	130	160	110	421.5	12	553.5	14	5	16.3
80/B5	4	9	12	165	200	130	421.5	12	553.5	19	6	21.8
80/B14	4	9	7	100	120	80	421.5	12	553.5	19	6	21.8
90/B5	4	9	12	165	200	130	421.5	12	553.5	24	8	27.3
90/B14	4	9	9	115	140	95	421.5	12	553.5	24	8	27.3
100/B5	4.5	9	15	215	250	180	438.5	15	570.5	28	8	31.3

KN574.03

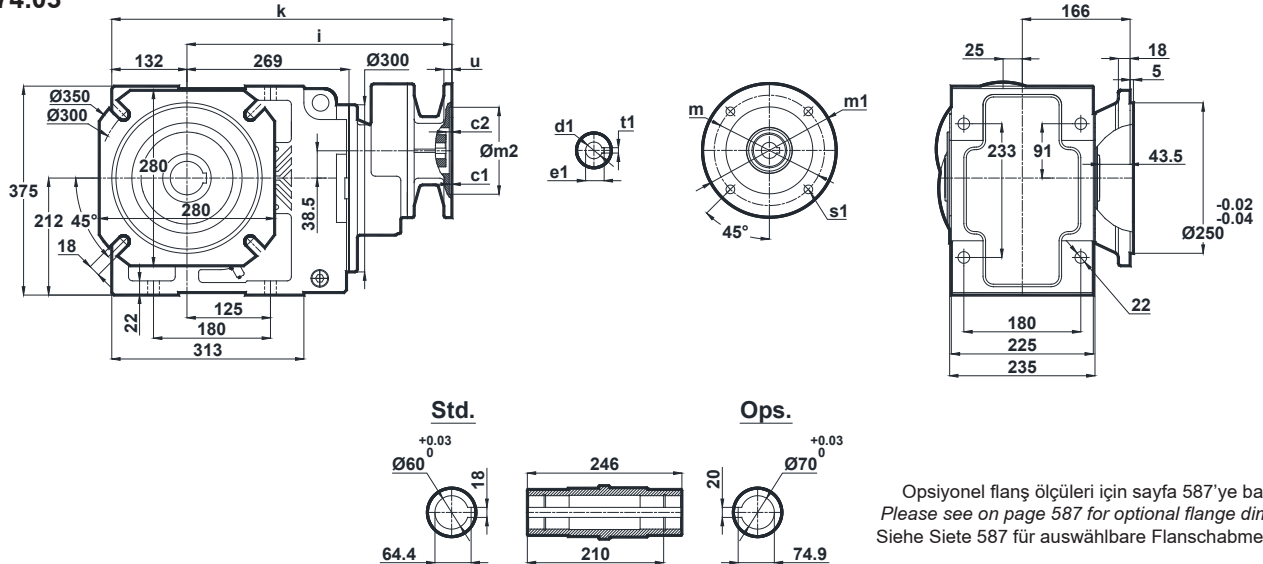

	c1	c2	s1	m	m1	m2	i	u	k	d1	t1	e1
71/B5	4	9	11	130	160	110	421.5	12	553.5	14	5	16.3
80/B5	4	9	12	165	200	130	421.5	12	553.5	19	6	21.8
80/B14	4	9	7	100	120	80	421.5	12	553.5	19	6	21.8
90/B5	4	9	12	165	200	130	421.5	12	553.5	24	8	27.3
90/B14	4	9	9	115	140	95	421.5	12	553.5	24	8	27.3
100/B5	4.5	9	15	215	250	180	438.5	15	570.5	28	8	31.3

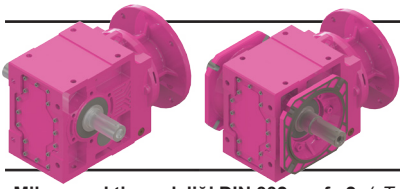

Ölçü Sayfaları Dimension Pages Abmessungsseiten

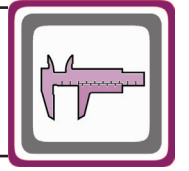

-Mil ucu çekirme deliği DIN 332 sayfa 2 / Tapped center hole to DIN 332, sheet 2 / Zentrierung mit Gewinde DIN 332, Blatt 2

KN574.04

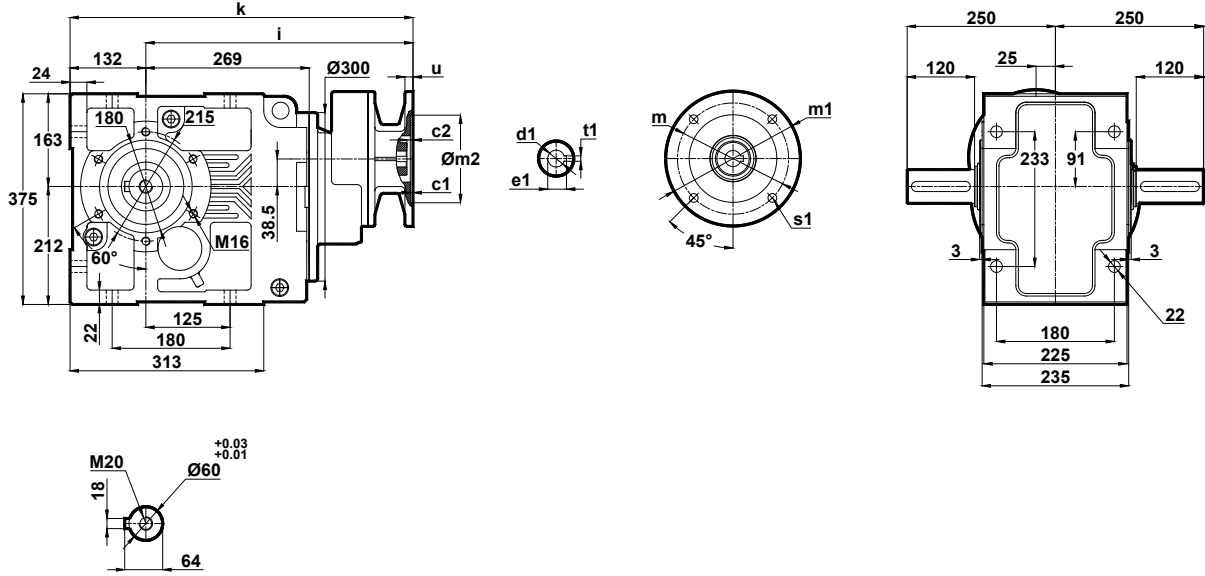

	c1	c2	s1	m	m1	m2	i	u	k	d1	t1	e1
71/B5	4	9	11	130	160	110	421.5	12	553.5	14	5	16.3
80/B5 80/B14	4	9	12 7	165 100	200 120	130 80	421.5	12	553.5	19	6	21.8
90/B5 90/B14	4	9	12 9	165 115	200 140	130 95	421.5	12	553.5	24	8	27.3
100/B5	4.5	9	15	215	250	180	438.5	15	570.5	28	8	31.3

KN574.05

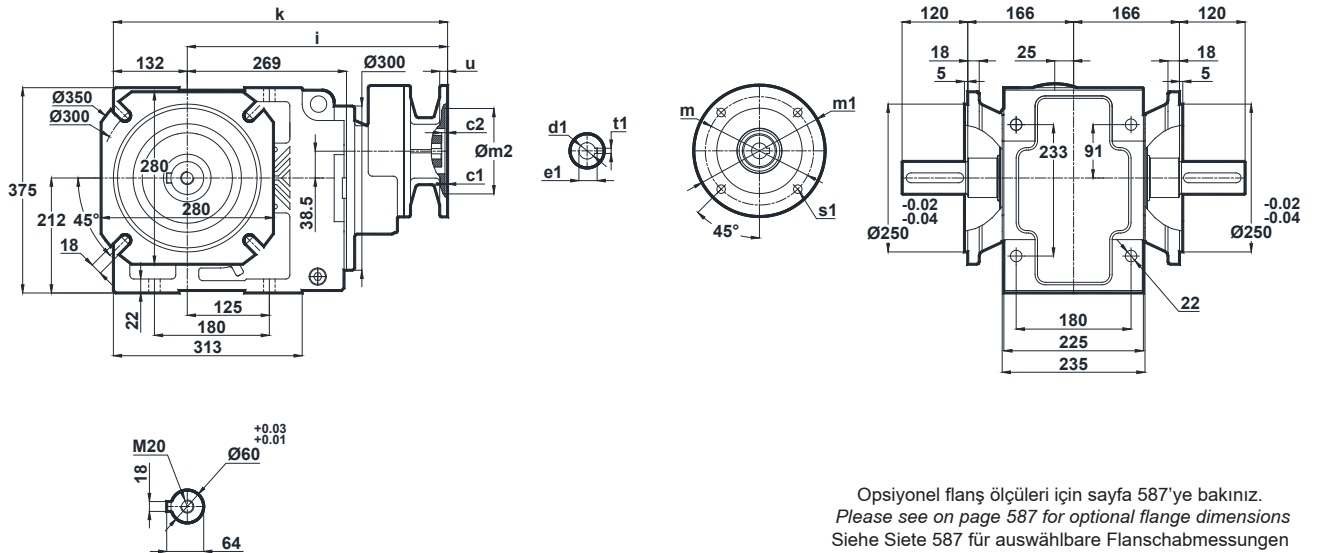

Opsiyonel flanş ölçüleri için sayfa 587'ye bakınız.
Please see on page 587 for optional flange dimensions
Siehe Seite 587 für auswählbare Flanschabmessungen

	c1	c2	s1	m	m1	m2	i	u	k	d1	t1	e1
71/B5	4	9	11	130	160	110	421.5	12	553.5	14	5	16.3
80/B5 80/B14	4	9	12 7	165 100	200 120	130 80	421.5	12	553.5	19	6	21.8
90/B5 90/B14	4	9	12 9	165 115	200 140	130 95	421.5	12	553.5	24	8	27.3
100/B5	4.5	9	15	215	250	180	438.5	15	570.5	28	8	31.3

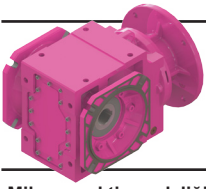

Ölçü Sayfaları Dimension Pages Abmessungenseiten

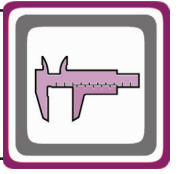

-Mil ucu çektirme deliği DIN 332 sayfa 2 / Tapped center hole to DIN 332, sheet 2 / Zentrierung mit Gewinde DIN 332, Blatt 2

KN574.08

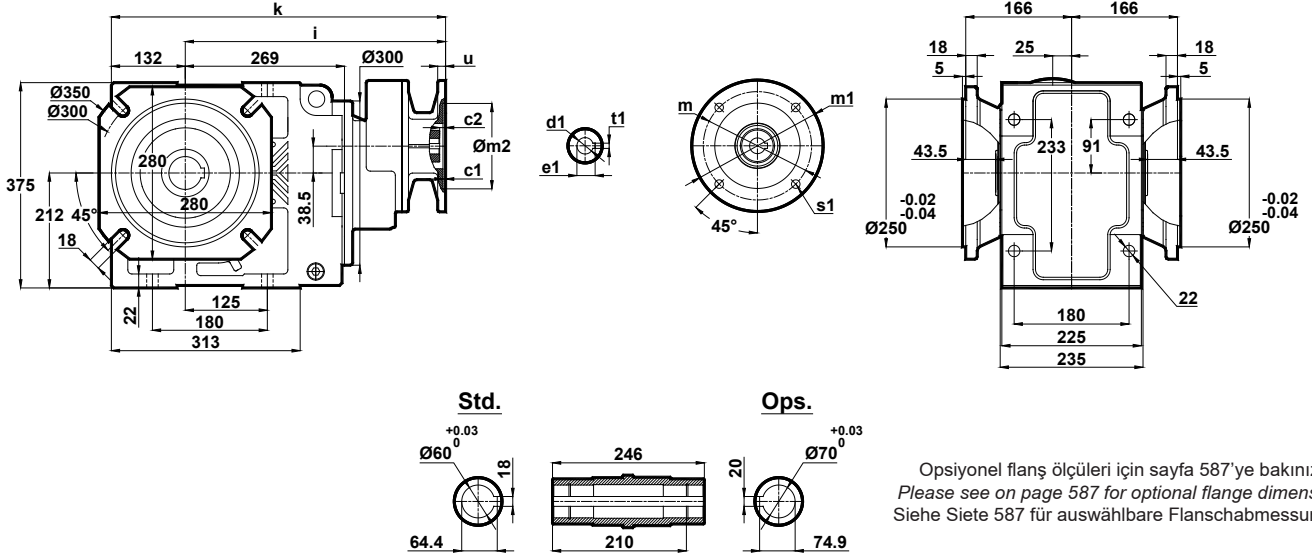

	c1	c2	s1	m	m1	m2	i	u	k	d1	t1	e1
71/B5	4	9	11	130	160	110	421.5	12	553.5	14	5	16.3
80/B5 80/B14	4	9	12 7	165 100	200 120	130 80	421.5	12	553.5	19	6	21.8
90/B5 90/B14	4	9	12 9	165 115	200 140	130 95	421.5	12	553.5	24	8	27.3
100/B5	4.5	9	15	215	250	180	438.5	15	570.5	28	8	31.3

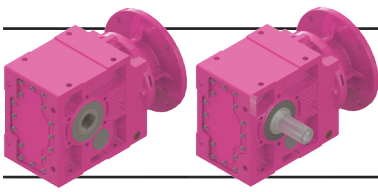

Ölçü Sayfaları

Dimension Pages

Abmessungsseiten

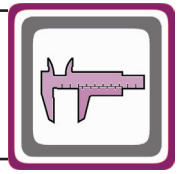

-Mil ucu çekirme deliği DIN 332 sayfa 2 / Tapped center hole to DIN 332, sheet 2 / Zentrierung mit Gewinde DIN 332, Blatt 2

KN575.00
KN576.00

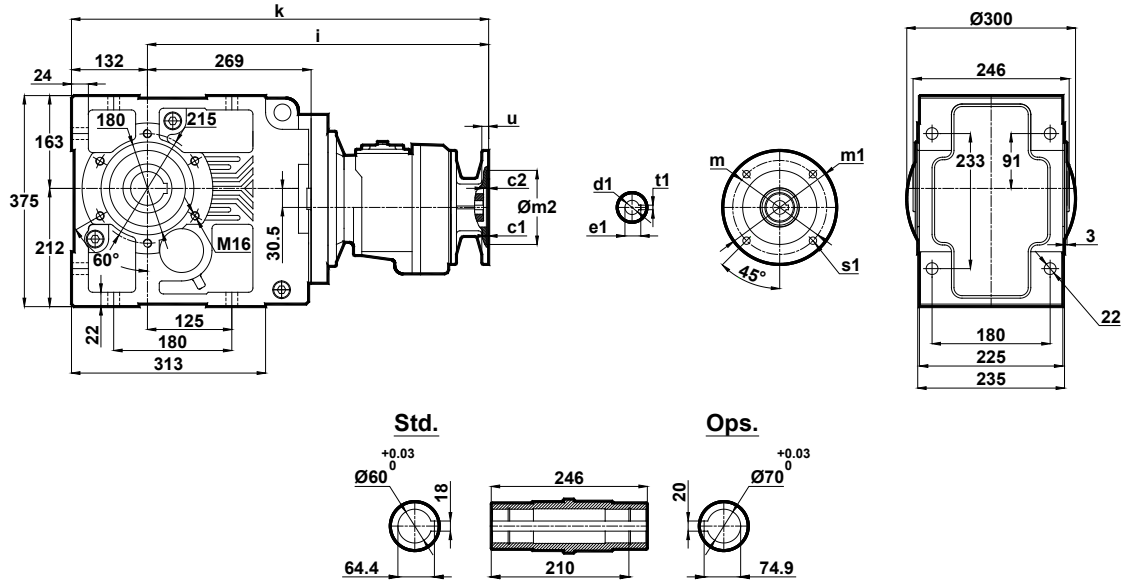

	c1	c2	s1	m	m1	m2	i	u	k	d1	t1	e1
63/B5	3.5	5	9	115	140	95	551.5	12	683.5	11	4	12.8
71/B5	4	8.5	11	130	160	110	522.5	12	654.5	14	5	16.3
71/B14	3		7	85	105	70		10				
80/B5	4	5	12	165	200	130	551.5	12	683.5	19	6	21.8
80/B14			7	100	120	80						

KN575.01
KN576.01

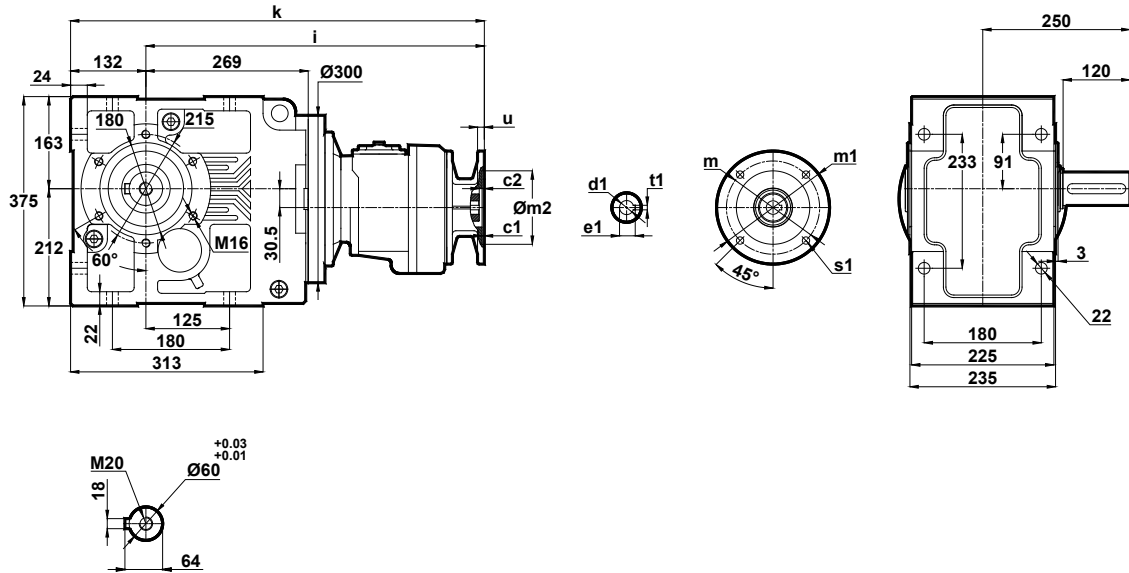

	c1	c2	s1	m	m1	m2	i	u	k	d1	t1	e1
63/B5	3.5	5	9	115	140	95	551.5	12	683.5	11	4	12.8
71/B5	4	8.5	11	130	160	110	522.5	12	654.5	14	5	16.3
71/B14	3		7	85	105	70		10				
80/B5	4	5	12	165	200	130	551.5	12	683.5	19	6	21.8
80/B14			7	100	120	80						

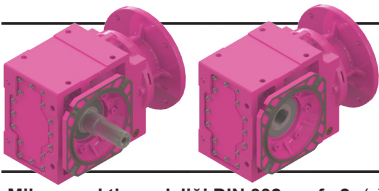

Ölçü Sayfaları Dimension Pages Abmessungsseiten

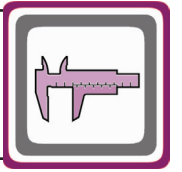

-Mil ucu çekirme deliği DIN 332 sayfa 2 / Tapped center hole to DIN 332, sheet 2 / Zentrierung mit Gewinde DIN 332, Blatt 2

KN575.02
KN576.02

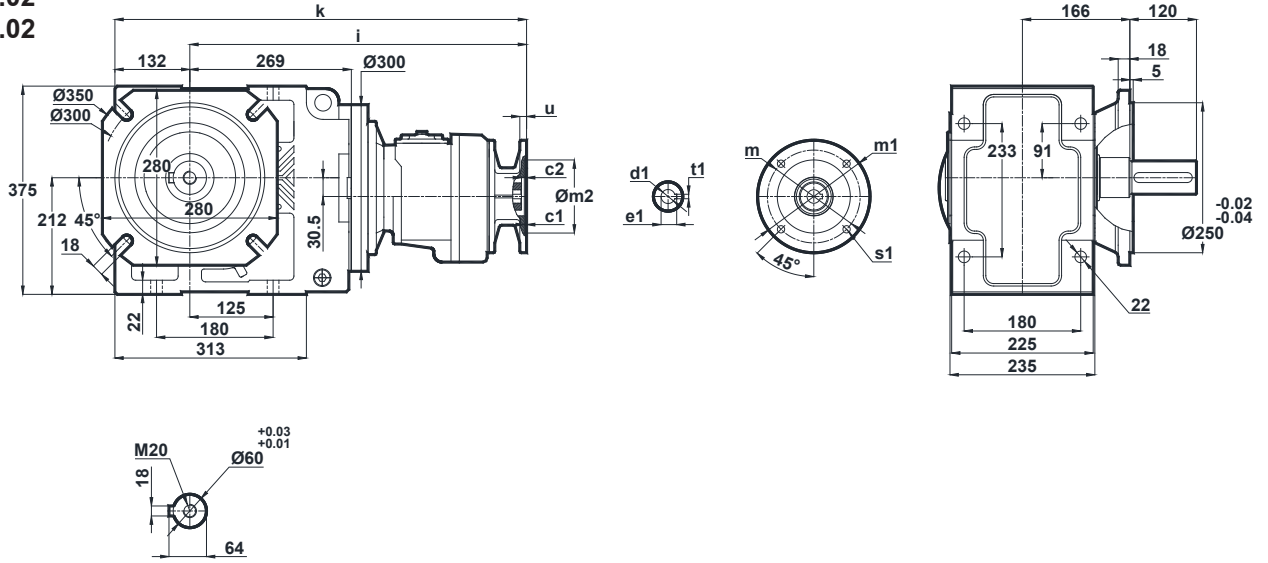

Opsiyonel flanş ölçüleri için sayfa 587'ye bakınız.
Please see on page 587 for optional flange dimensions
Siehe Seite 587 für auswählbare Flanschabmessungen

	c1	c2	s1	m	m1	m2	i	u	k	d1	t1	e1
63/B5	3.5	5	9	115	140	95	551.5	12	683.5	11	4	12.8
71/B5	4	8.5	11	130	160	110	522.5	12	654.5	14	5	16.3
71/B14	3		7	85	105	70						
80/B5	4	5	12	165	200	130	551.5	12	683.5	19	6	21.8
80/B14			7	100	120	80						

KN575.03
KN576.03

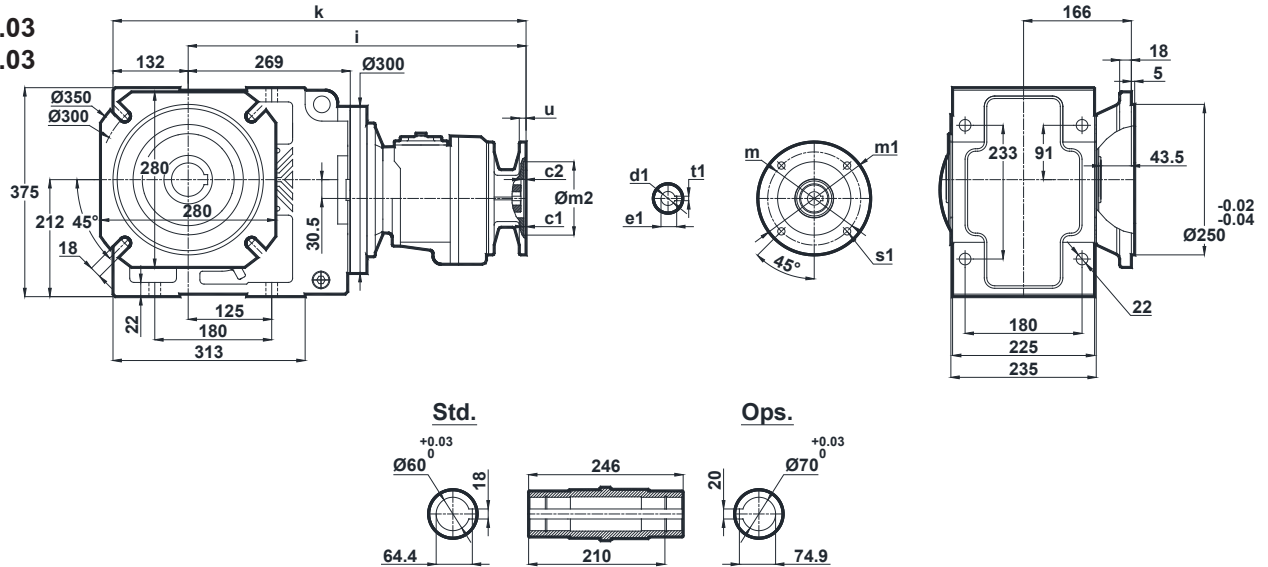

Opsiyonel flanş ölçüleri için sayfa 587'ye bakınız.
Please see on page 587 for optional flange dimensions
Siehe Seite 587 für auswählbare Flanschabmessungen

	c1	c2	s1	m	m1	m2	i	u	k	d1	t1	e1
63/B5	3.5	5	9	115	140	95	551.5	12	683.5	11	4	12.8
71/B5	4	8.5	11	130	160	110	522.5	12	654.5	14	5	16.3
71/B14	3		7	85	105	70						
80/B5	4	5	12	165	200	130	551.5	12	683.5	19	6	21.8
80/B14			7	100	120	80						

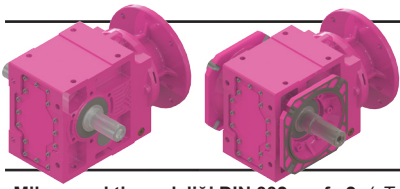

Ölçü Sayfaları

Dimension Pages

Abmessungsseiten

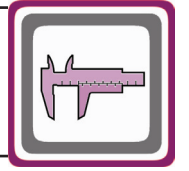

-Mil ucu çektirme deliği DIN 332 sayfa 2 / Tapped center hole to DIN 332, sheet 2 / Zentrierung mit Gewinde DIN 332, Blatt 2

KN575.04
KN576.04

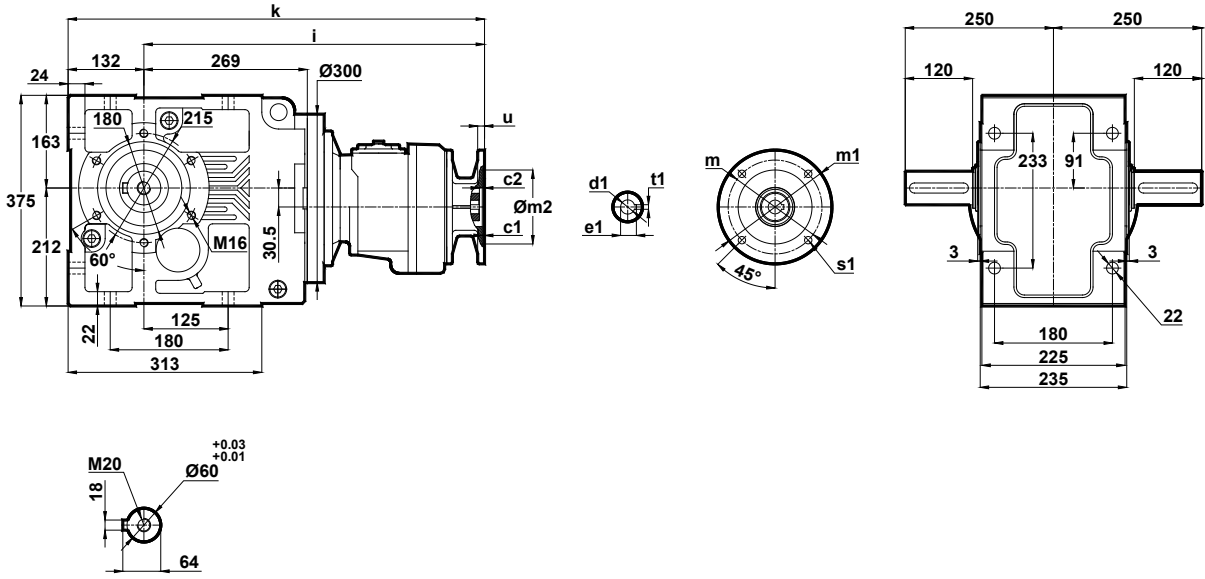

	c1	c2	s1	m	m1	m2	i	u	k	d1	t1	e1
63/B5	3.5	5	9	115	140	95	551.5	12	683.5	11	4	12.8
71/B5	4	8.5	11	130	160	110	522.5	12	654.5	14	5	16.3
71/B14	3		7	85	105	70		10				
80/B5	4	5	12	165	200	130	551.5	12	683.5	19	6	21.8
80/B14			7	100	120	80						

KN575.05
KN576.05

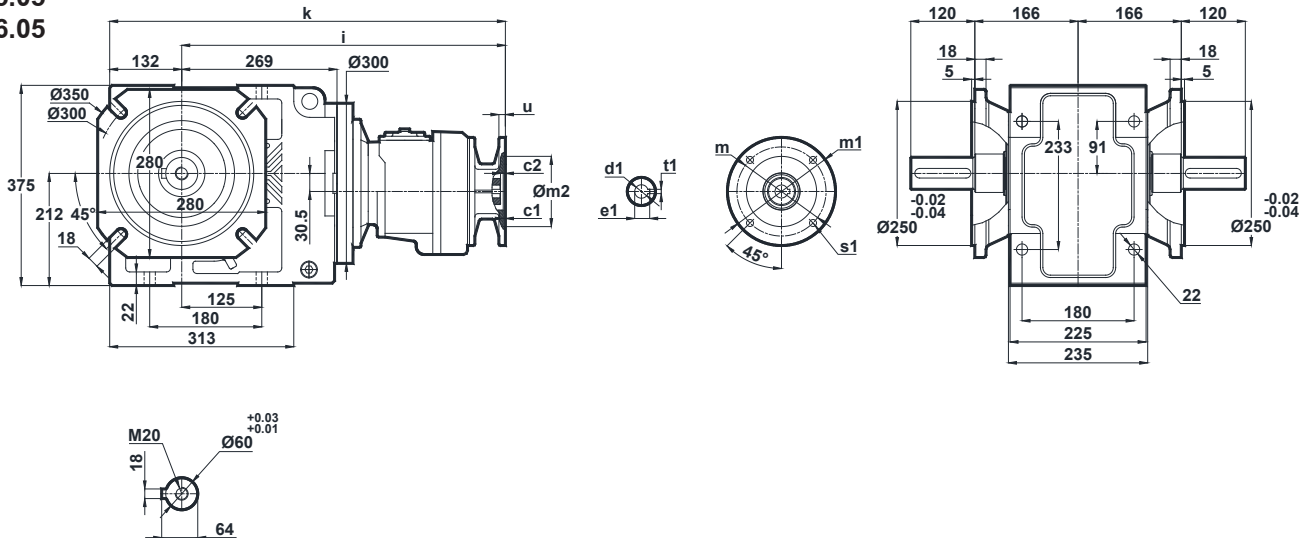

Opsiyonel flanş ölçüleri için sayfa 587'ye bakınız.
Please see on page 587 for optional flange dimensions
Siehe Seite 587 für auswählbare Flanschabmessungen

	c1	c2	s1	m	m1	m2	i	u	k	d1	t1	e1
63/B5	3.5	5	9	115	140	95	551.5	12	683.5	11	4	12.8
71/B5	4	8.5	11	130	160	110	522.5	12	654.5	14	5	16.3
71/B14	3		7	85	105	70		10				
80/B5	4	5	12	165	200	130	551.5	12	683.5	19	6	21.8
80/B14			7	100	120	80						

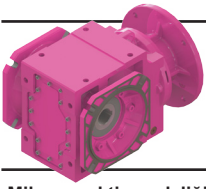

Ölçü Sayfaları Dimension Pages Abmessungsseiten

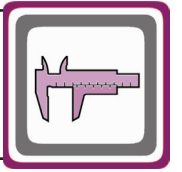

-Mil ucu çektirme deliği DIN 332 sayfa 2 / Tapped center hole to DIN 332, sheet 2 / Zentrierung mit Gewinde DIN 332, Blatt 2

KN575.08
KN576.08

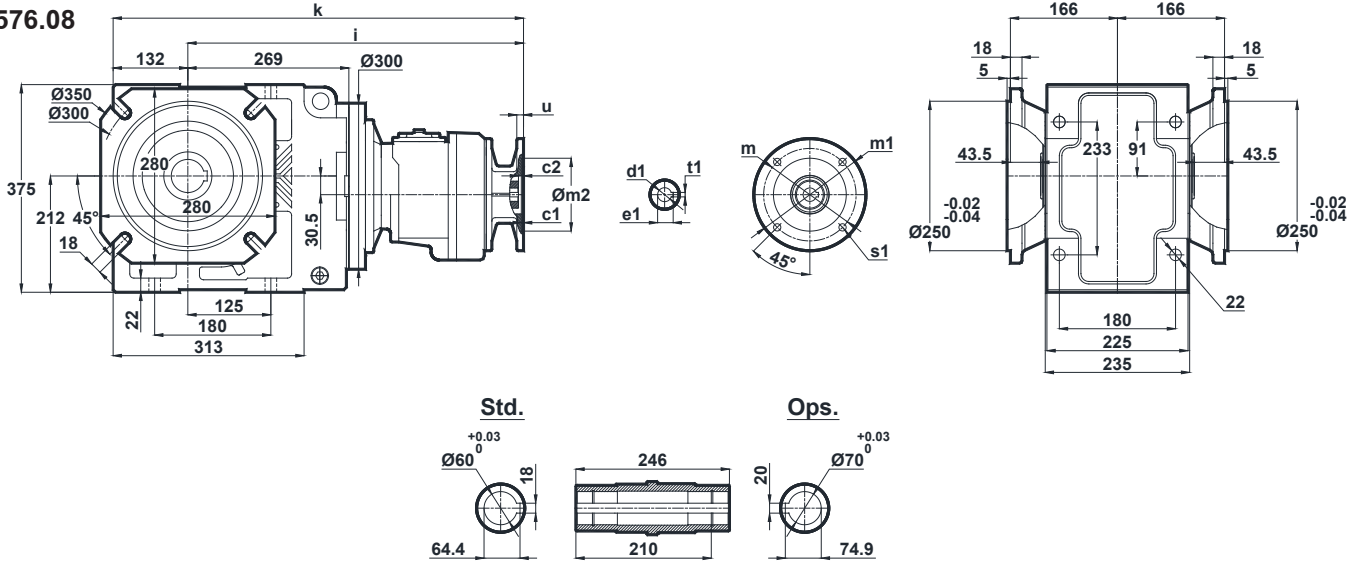

Opsiyonel flanş ölçüleri için sayfa 587'ye bakınız.
Please see on page 587 for optional flange dimensions
Siehe Seite 587 für auswählbare Flanschabmessungen

	c1	c2	s1	m	m1	m2	i	u	k	d1	t1	e1
63/B5	3.5	5	9	115	140	95	551.5	12	683.5	11	4	12.8
71/B5	4											
71/B14	3	8.5	11	130	160	110	522.5	12	654.5	14	5	16.3
80/B5												
80/B14	4	5	12	165	200	130	551.5	12	683.5	19	6	21.8

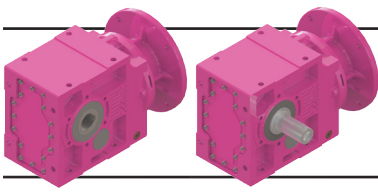

Ölçü Sayfaları

Dimension Pages

Abmessungsseiten

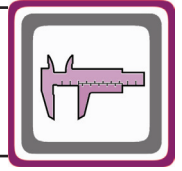

-Mil ucu çekirme deliği DIN 332 sayfa 2 / Tapped center hole to DIN 332, sheet 2 / Zentrierung mit Gewinde DIN 332, Blatt 2

KN673.00

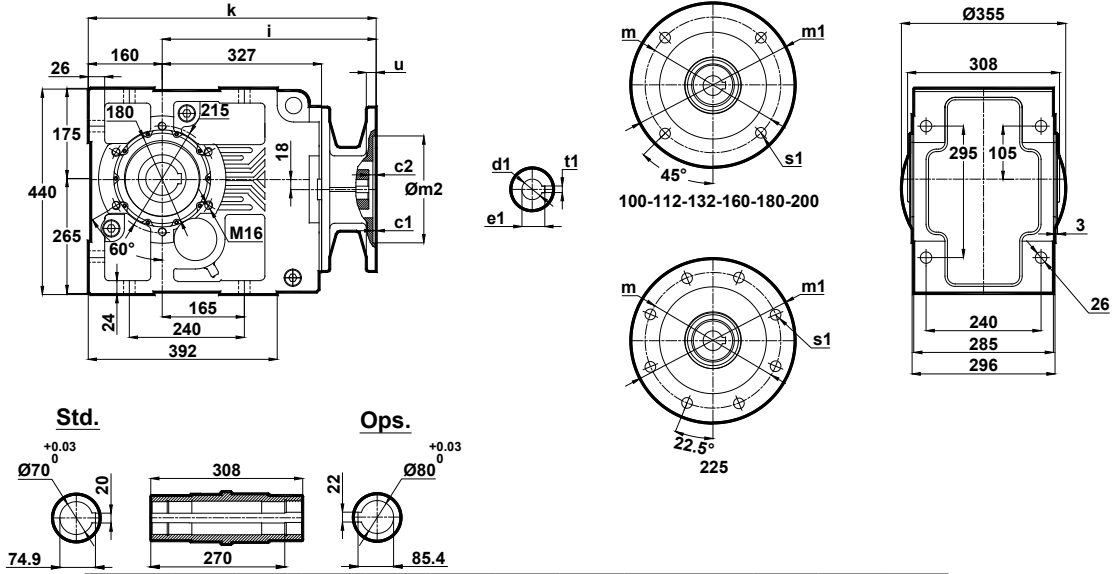

	c1	c2	s1	m	m1	m2	i	u	k	d1	t1	e1
100/B5	4.5	14.5	15	215	250	180	395.5	15	555.5	28	8	31.3
112/B5	4.5	14.5	15	215	250	180	395.5	15	555.5	28	8	31.3
132/B5 132/B14	4.5	9	15	265 165	300 200	230 130	410.5	15	570.5	38	10	41.3
160/B5	5.5	10	19	300	350	250	485.5	20	645.5	42	12	45.3
180/B5	5.5	10	19	300	350	250	485.5	20	645.5	48	14	51.8
200/B5	5.5	10	19	350	400	300	506	22	666	55	16	59.3
225/B5	5.5	10	19	400	450	350	559	24	719	60	18	64.4

KN673.01

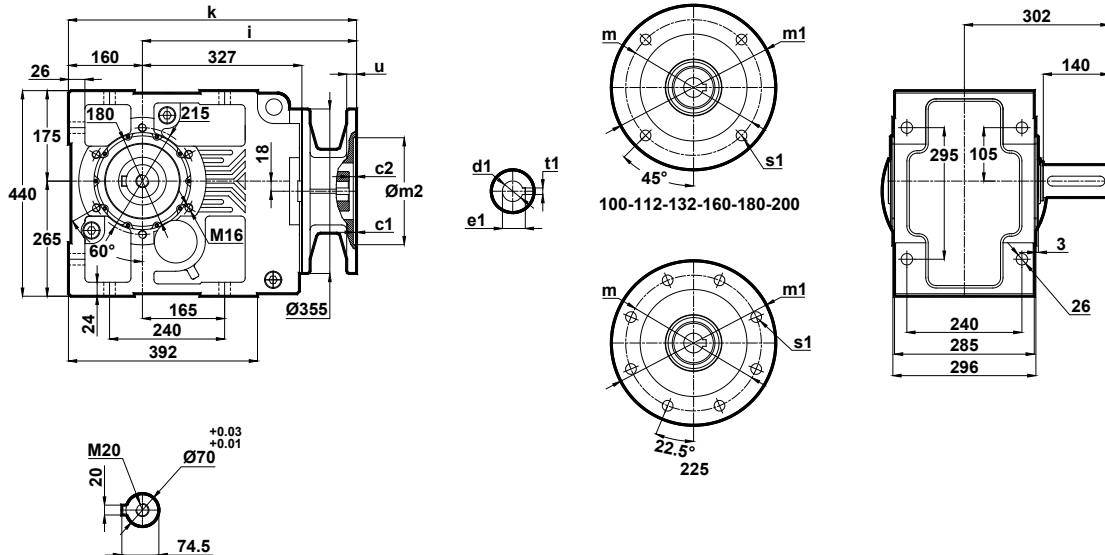

	c1	c2	s1	m	m1	m2	i	u	k	d1	t1	e1
100/B5	4.5	14.5	15	215	250	180	395.5	15	555.5	28	8	31.3
112/B5	4.5	14.5	15	215	250	180	395.5	15	555.5	28	8	31.3
132/B5 132/B14	4.5	9	15	265 165	300 200	230 130	410.5	15	570.5	38	10	41.3
160/B5	5.5	10	19	300	350	250	485.5	20	645.5	42	12	45.3
180/B5	5.5	10	19	300	350	250	485.5	20	645.5	48	14	51.8
200/B5	5.5	10	19	350	400	300	506	22	666	55	16	59.3
225/B5	5.5	10	19	400	450	350	559	24	719	60	18	64.4

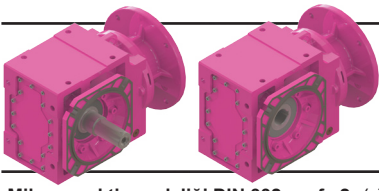

Ölçü Sayfaları

Dimension Pages

Abmessungsseiten

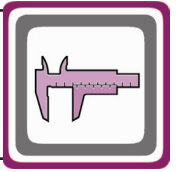

-Mil ucu çekirme deliği DIN 332 sayfa 2 / Tapped center hole to DIN 332, sheet 2 / Zentrierung mit Gewinde DIN 332, Blatt 2

KN673.02

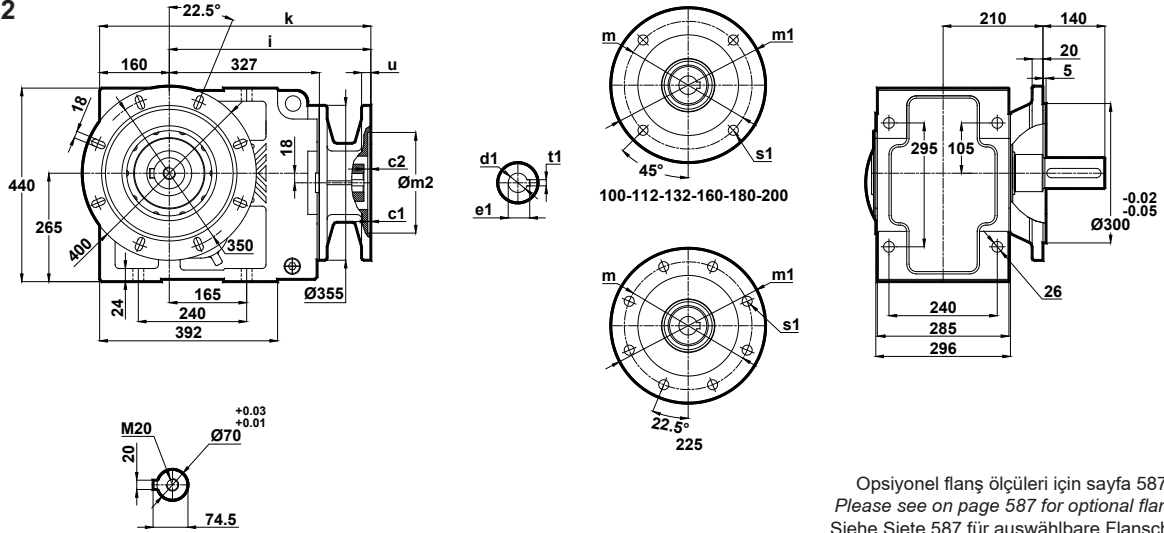

Opsiyonel flanş ölçüleri için sayfa 587'ye bakınız.
Please see on page 587 for optional flange dimensions
Siehe Seite 587 für auswählbare Flanschabmessungen

	c1	c2	s1	m	m1	m2	i	u	k	d1	t1	e1
100/B5	4.5	14.5	15	215	250	180	395.5	15	555.5	28	8	31.3
112/B5	4.5	14.5	15	215	250	180	395.5	15	555.5	28	8	31.3
132/B5 132/B14	4.5	9	15	265 165	300 200	230 130	410.5	15	570.5	38	10	41.3
160/B5	5.5	10	19	300	350	250	485.5	20	645.5	42	12	45.3
180/B5	5.5	10	19	300	350	250	485.5	20	645.5	48	14	51.8
200/B5	5.5	10	19	350	400	300	506	22	666	55	16	59.3
225/B5	5.5	10	19	400	450	350	559	24	719	60	18	64.4

KN673.03

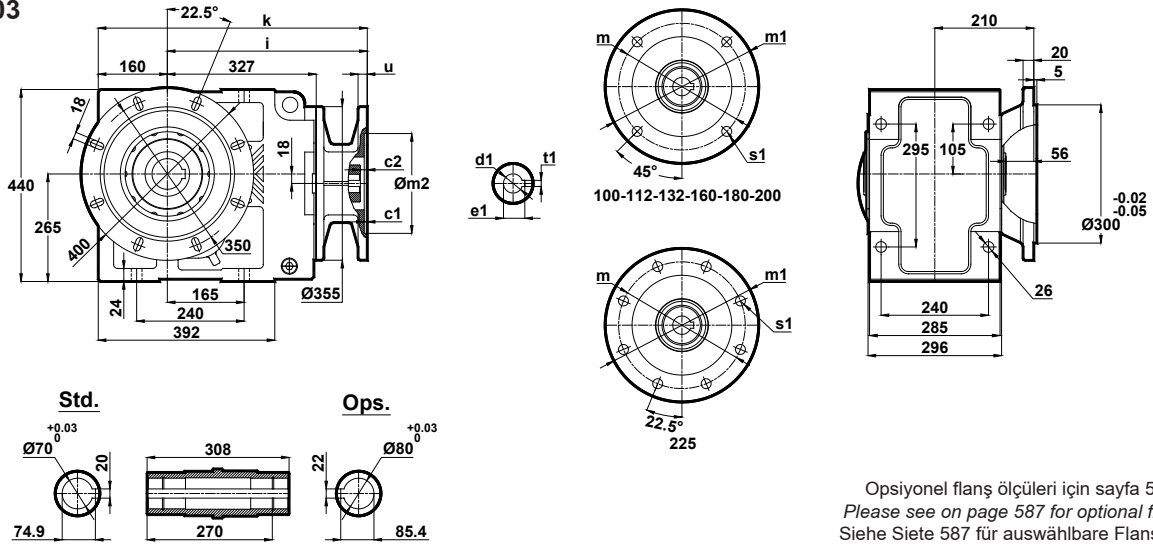

Opsiyonel flanş ölçüleri için sayfa 587'ye bakınız.
Please see on page 587 for optional flange dimensions
Siehe Seite 587 für auswählbare Flanschabmessungen

	c1	c2	s1	m	m1	m2	i	u	k	d1	t1	e1
100/B5	4.5	14.5	15	215	250	180	395.5	15	555.5	28	8	31.3
112/B5	4.5	14.5	15	215	250	180	395.5	15	555.5	28	8	31.3
132/B5 132/B14	4.5	9	15	265 165	300 200	230 130	410.5	15	570.5	38	10	41.3
160/B5	5.5	10	19	300	350	250	485.5	20	645.5	42	12	45.3
180/B5	5.5	10	19	300	350	250	485.5	20	645.5	48	14	51.8
200/B5	5.5	10	19	350	400	300	506	22	666	55	16	59.3
225/B5	5.5	10	19	400	450	350	559	24	719	60	18	64.4

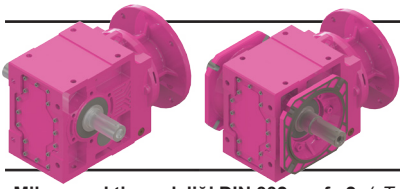

Ölçü Sayfaları Dimension Pages Abmessungsseiten

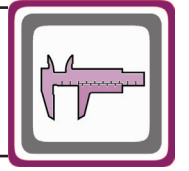

-Mil ucu çekirme deliği DIN 332 sayfa 2 / Tapped center hole to DIN 332, sheet 2 / Zentrierung mit Gewinde DIN 332, Blatt 2

KN673.04

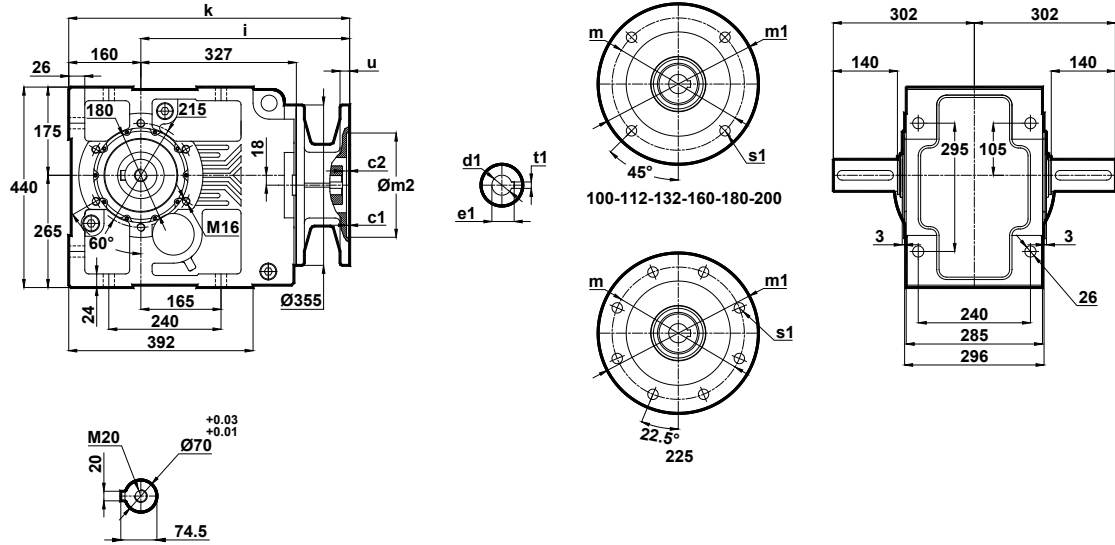

	c1	c2	s1	m	m1	m2	i	u	k	d1	t1	e1
100/B5	4.5	14.5	15	215	250	180	395.5	15	555.5	28	8	31.3
112/B5	4.5	14.5	15	215	250	180	395.5	15	555.5	28	8	31.3
132/B5 132/B14	4.5	9	15	265 165	300 200	230 130	410.5	15	570.5	38	10	41.3
160/B5	5.5	10	19	300	350	250	485.5	20	645.5	42	12	45.3
180/B5	5.5	10	19	300	350	250	485.5	20	645.5	48	14	51.8
200/B5	5.5	10	19	350	400	300	506	22	666	55	16	59.3
225/B5	5.5	10	19	400	450	350	559	24	719	60	18	64.4

KN673.05

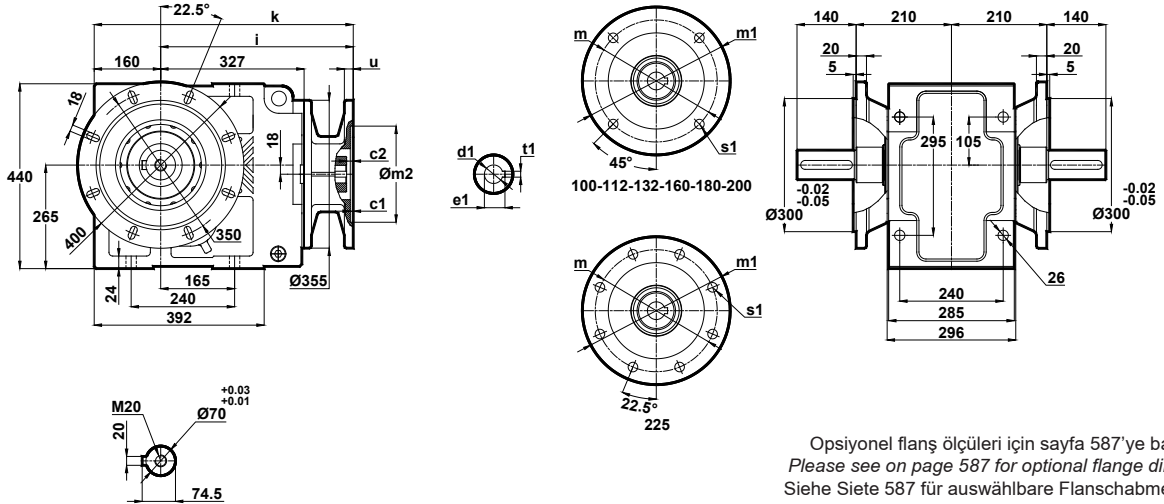

Opsiyonel flanş ölçüleri için sayfa 587'ye bakınız.
Please see on page 587 for optional flange dimensions
Siehe Seite 587 für auswählbare Flanschabmessungen

	c1	c2	s1	m	m1	m2	i	u	k	d1	t1	e1
100/B5	4.5	14.5	15	215	250	180	395.5	15	555.5	28	8	31.3
112/B5	4.5	14.5	15	215	250	180	395.5	15	555.5	28	8	31.3
132/B5 132/B14	4.5	9	15	265 165	300 200	230 130	410.5	15	570.5	38	10	41.3
160/B5	5.5	10	19	300	350	250	485.5	20	645.5	42	12	45.3
180/B5	5.5	10	19	300	350	250	485.5	20	645.5	48	14	51.8
200/B5	5.5	10	19	350	400	300	506	22	666	55	16	59.3
225/B5	5.5	10	19	400	450	350	559	24	719	60	18	64.4

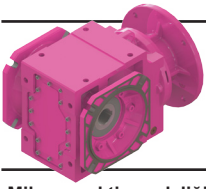

Ölçü Sayfaları Dimension Pages Abmessungenseiten

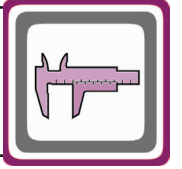

-Mil ucu çektirme deliği DIN 332 sayfa 2 / Tapped center hole to DIN 332, sheet 2 / Zentrierung mit Gewinde DIN 332, Blatt 2

KN673.08

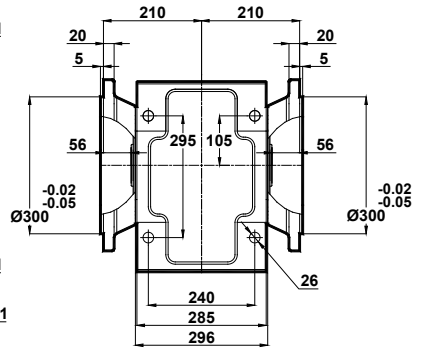
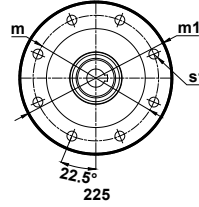
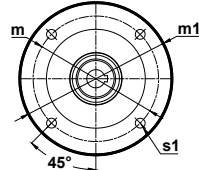
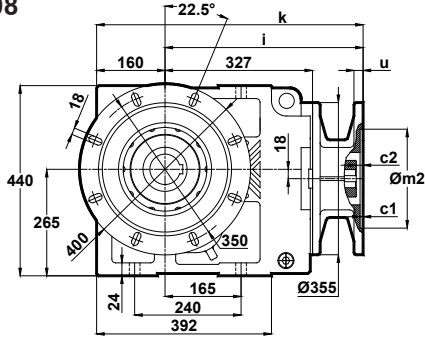

Std.

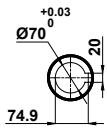

Ops.

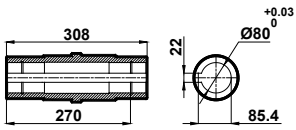

Opsiyonel flanş ölçüleri için sayfa 587'ye bakınız.
Please see on page 587 for optional flange dimensions
Siehe Seite 587 für auswählbare Flanschabmessungen

	c1	c2	s1	m	m1	m2	i	u	k	d1	t1	e1
100/B5	4.5	14.5	15	215	250	180	395.5	15	555.5	28	8	31.3
112/B5	4.5	14.5	15	215	250	180	395.5	15	555.5	28	8	31.3
132/B5 132/B14	4.5	9	15	265 165	300 200	230 130	410.5	15	570.5	38	10	41.3
160/B5	5.5	10	19	300	350	250	485.5	20	645.5	42	12	45.3
180/B5	5.5	10	19	300	350	250	485.5	20	645.5	48	14	51.8
200/B5	5.5	10	19	350	400	300	506	22	666	55	16	59.3
225/B5	5.5	10	19	400	450	350	559	24	719	60	18	64.4

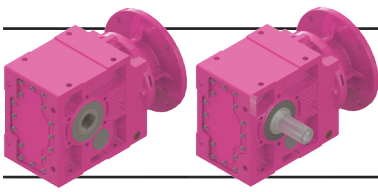

Ölçü Sayfaları

Dimension Pages

Abmessungsseiten

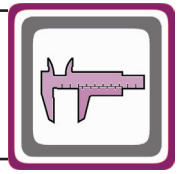

-Mil ucu çekirme deliği DIN 332 sayfa 2 / Tapped center hole to DIN 332, sheet 2 / Zentrierung mit Gewinde DIN 332, Blatt 2

KN674.00

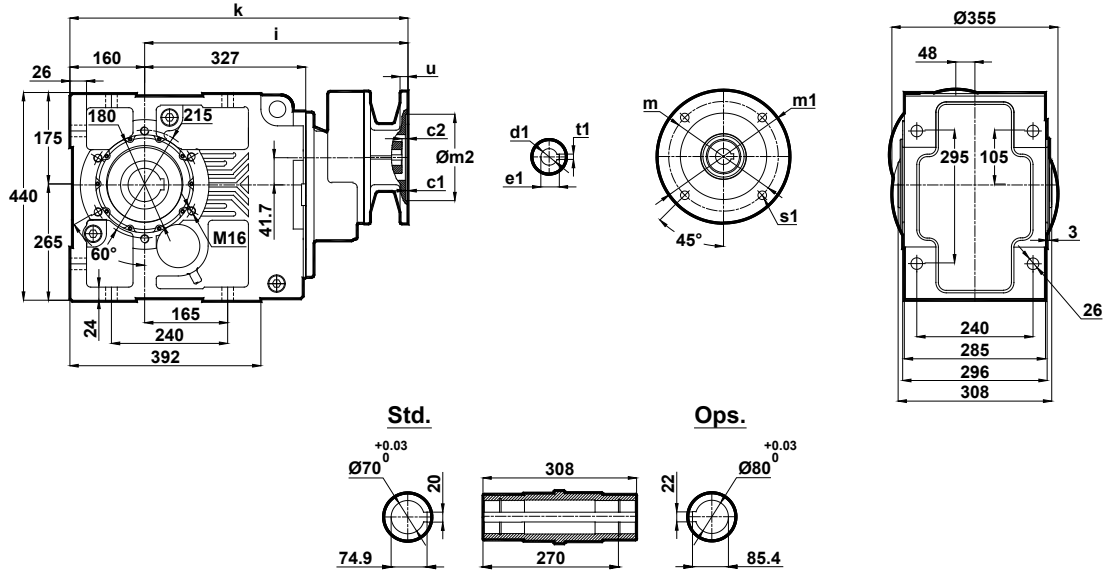

	c1	c2	s1	m	m1	m2	i	u	k	d1	t1	e1
80/B5	4	5	12	165	200	130	485.5	12	645.5	19	6	21.8
90/B5	4	5	13	165	200	130	485.5	12	645.5	24	8	27.3
90/B14			9	115	140	95						
100/B5	4.5	9	15	215	250	180	504	15	664	28	8	31.3
100/B14	4		9	130	160	110						

KN674.01

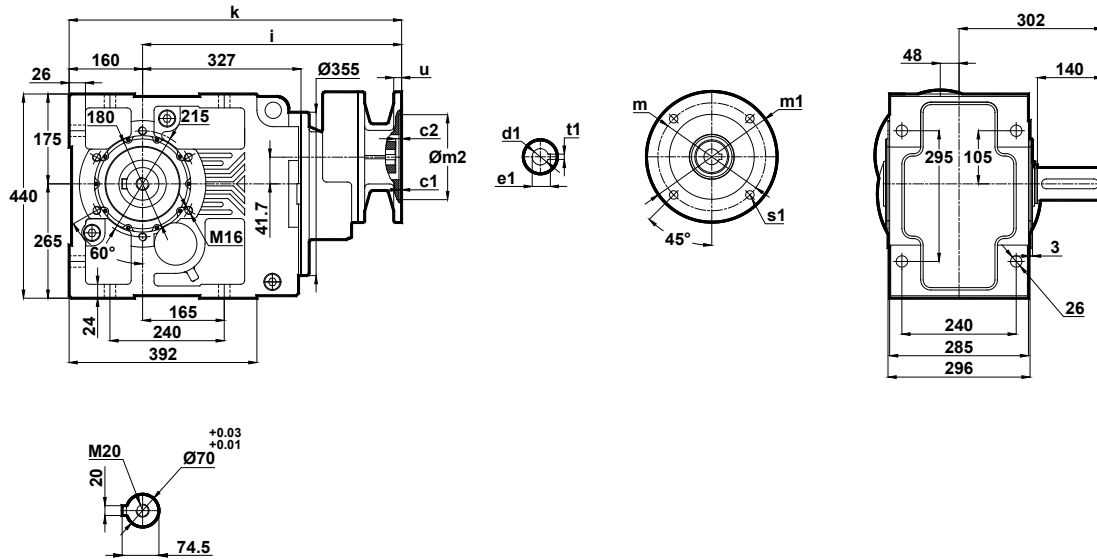

	c1	c2	s1	m	m1	m2	i	u	k	d1	t1	e1
80/B5	4	5	12	165	200	130	485.5	12	645.5	19	6	21.8
90/B5	4	5	13	165	200	130	485.5	12	645.5	24	8	27.3
90/B14			9	115	140	95						
100/B5	4.5	9	15	215	250	180	504	15	664	28	8	31.3
100/B14	4		9	130	160	110						

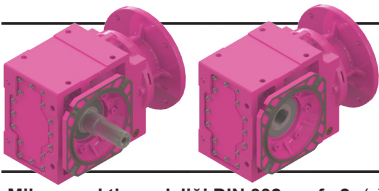

Ölçü Sayfaları

Dimension Pages

Abmessungsseiten

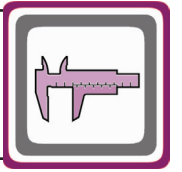

-Mil ucu çekirme deliği DIN 332 sayfa 2 / Tapped center hole to DIN 332, sheet 2 / Zentrierung mit Gewinde DIN 332, Blatt 2

KN674.02

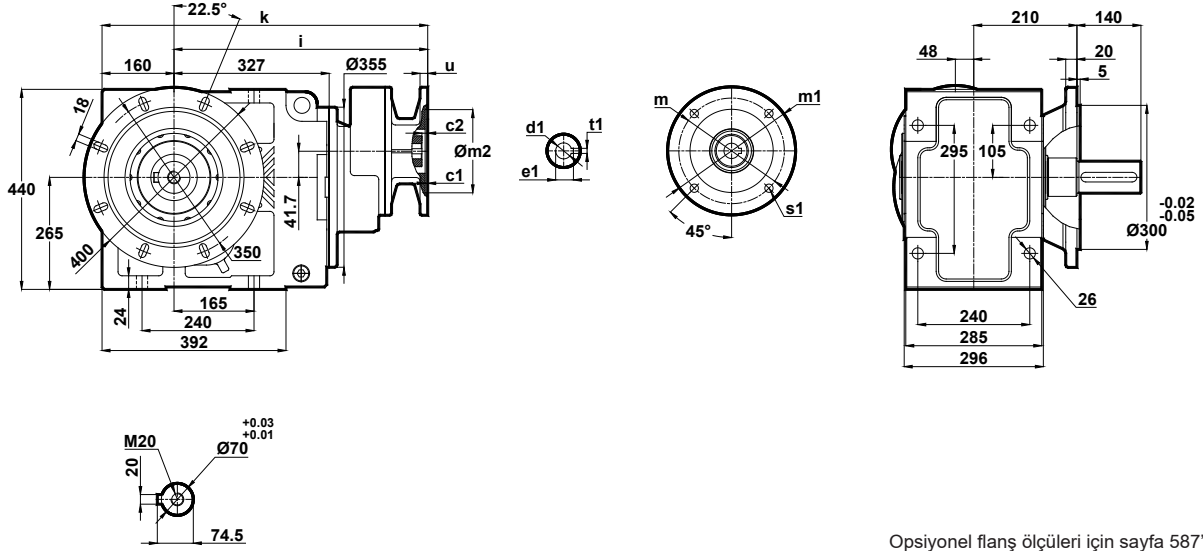

Opsiyonel flanş ölçüleri için sayfa 587'ye bakınız.
Please see on page 587 for optional flange dimensions
Siehe Seite 587 für auswählbare Flanschabmessungen

	c1	c2	s1	m	m1	m2	i	u	k	d1	t1	e1
80/B5	4	5	12	165	200	130	485.5	12	645.5	19	6	21.8
90/B5 90/B14	4	5	13 9	165 115	200 140	130 95	485.5	12	645.5	24	8	27.3
100/B5 100/B14	4.5 4	9	15 9	215 130	250 160	180 110	504	15	664	28	8	31.3

KN674.03

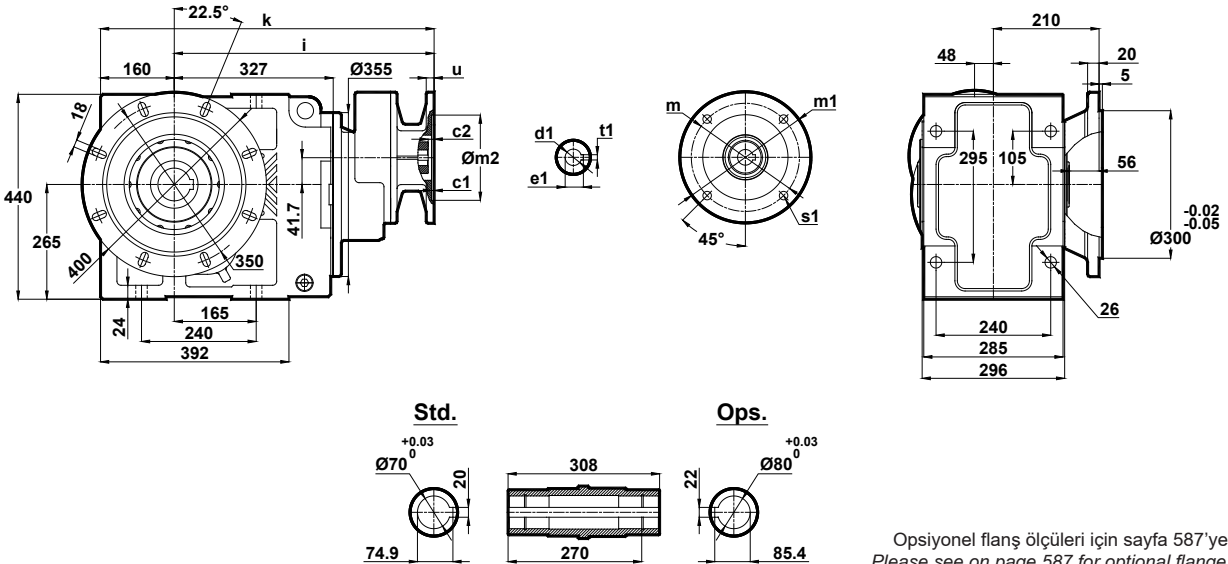

Opsiyonel flanş ölçüleri için sayfa 587'ye bakınız.
Please see on page 587 for optional flange dimensions
Siehe Seite 587 für auswählbare Flanschabmessungen

	c1	c2	s1	m	m1	m2	i	u	k	d1	t1	e1
80/B5	4	5	12	165	200	130	485.5	12	645.5	19	6	21.8
90/B5 90/B14	4	5	13 9	165 115	200 140	130 95	485.5	12	645.5	24	8	27.3
100/B5 100/B14	4.5 4	9	15 9	215 130	250 160	180 110	504	15	664	28	8	31.3

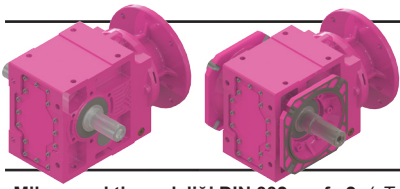

Ölçü Sayfaları

Dimension Pages

Abmessungsseiten

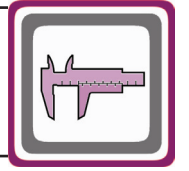

-Mil ucu çektirme deliği DIN 332 sayfa 2 / Tapped center hole to DIN 332, sheet 2 / Zentrierung mit Gewinde DIN 332, Blatt 2

KN674.04

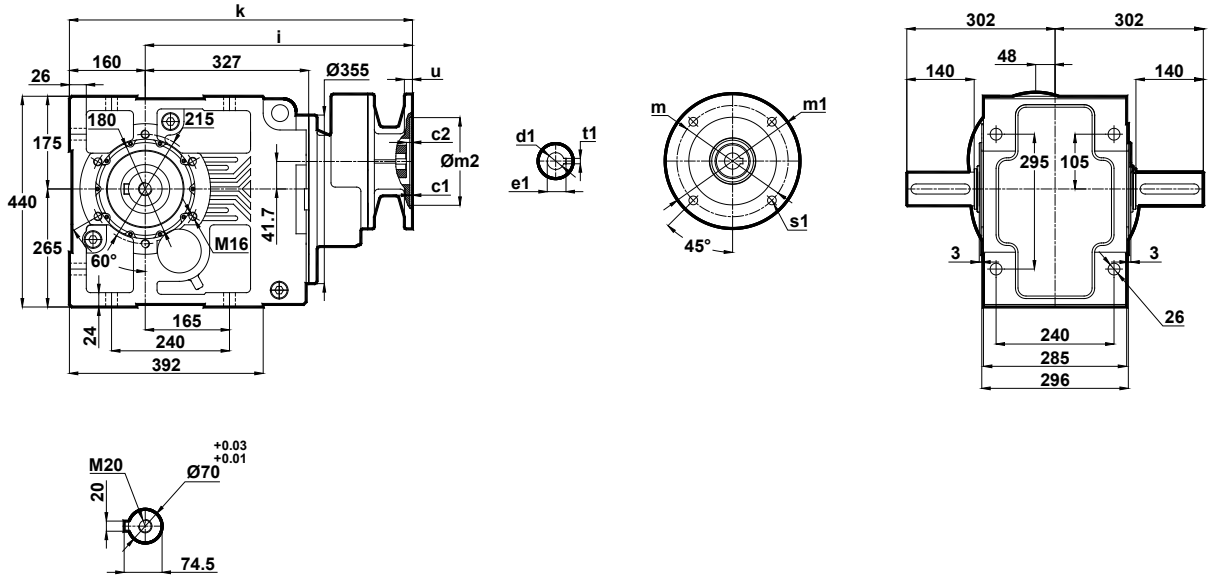

	c1	c2	s1	m	m1	m2	i	u	k	d1	t1	e1
80/B5	4	5	12	165	200	130	485.5	12	645.5	19	6	21.8
90/B5	4	5	13	165	200	130	485.5	12	645.5	24	8	27.3
90/B14			9	115	140	95						
100/B5	4.5	9	15	215	250	180	504	15	664	28	8	31.3
100/B14	4		9	130	160	110						

KN674.05

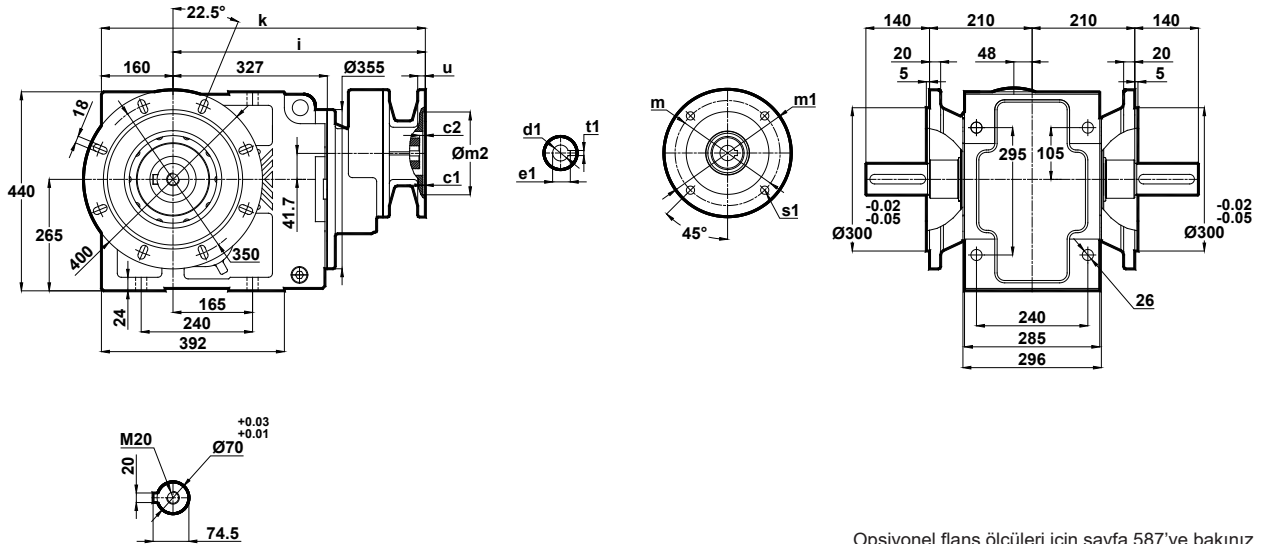

Opsiyonel flanş ölçüleri için sayfa 587'ye bakınız.
Please see on page 587 for optional flange dimensions
Siehe Seite 587 für auswählbare Flanschabmessungen

	c1	c2	s1	m	m1	m2	i	u	k	d1	t1	e1
80/B5	4	5	12	165	200	130	485.5	12	645.5	19	6	21.8
90/B5	4	5	13	165	200	130	485.5	12	645.5	24	8	27.3
90/B14			9	115	140	95						
100/B5	4.5	9	15	215	250	180	504	15	664	28	8	31.3
100/B14	4		9	130	160	110						

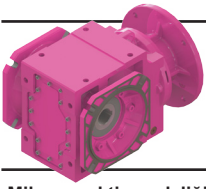

Ölçü Sayfaları Dimension Pages Abmessungenseiten

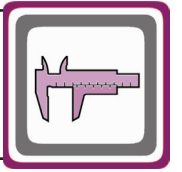

-Mil ucu çekirme deliği DIN 332 sayfa 2 / Tapped center hole to DIN 332, sheet 2 / Zentrierung mit Gewinde DIN 332, Blatt 2

KN674.08

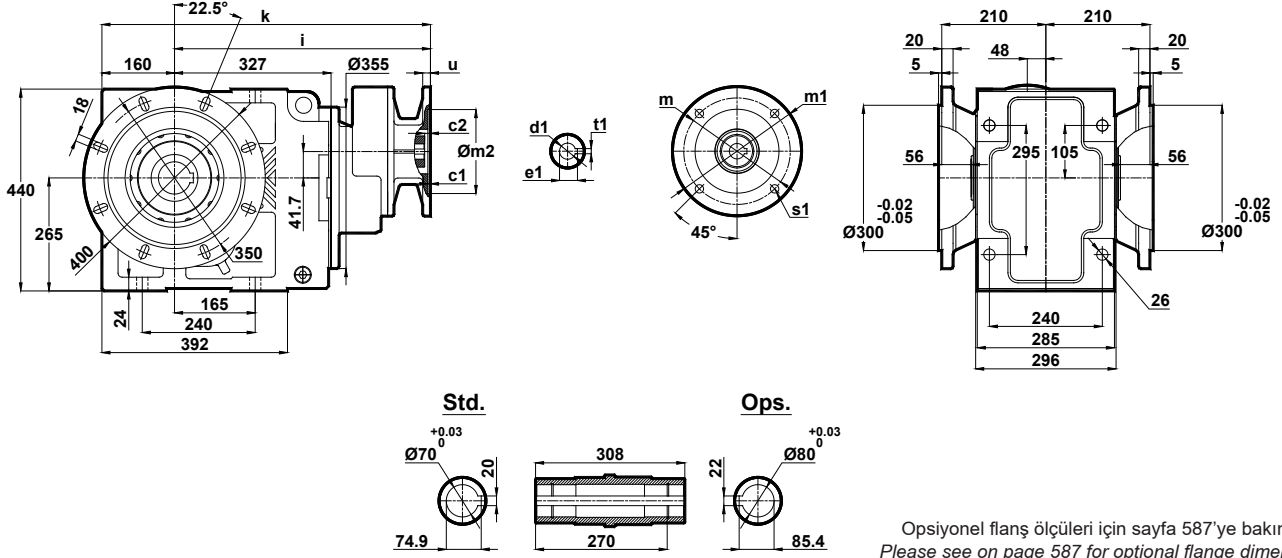

Opsiyonel flanş ölçüleri için sayfa 587'ye bakınız.
Please see on page 587 for optional flange dimensions
Siehe Seite 587 für auswählbare Flanschabmessungen

	c1	c2	s1	m	m1	m2	i	u	k	d1	t1	e1
80/B5	4	5	12	165	200	130	485.5	12	645.5	19	6	21.8
90/B5	4	5	13	165	200	130	485.5	12	645.5	24	8	27.3
90/B14			9	115	140	95						
100/B5	4.5	9	15	215	250	180	504	15	664	28	8	31.3
100/B14	4		9	130	160	110						

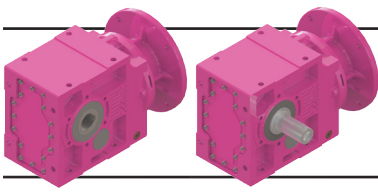

Ölçü Sayfaları

Dimension Pages

Abmessungsseiten

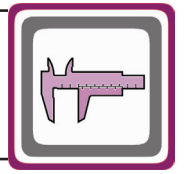

-Mil ucu çektirme deliği DIN 332 sayfa 2 / Tapped center hole to DIN 332, sheet 2 / Zentrierung mit Gewinde DIN 332, Blatt 2

KN675.00
KN676.00

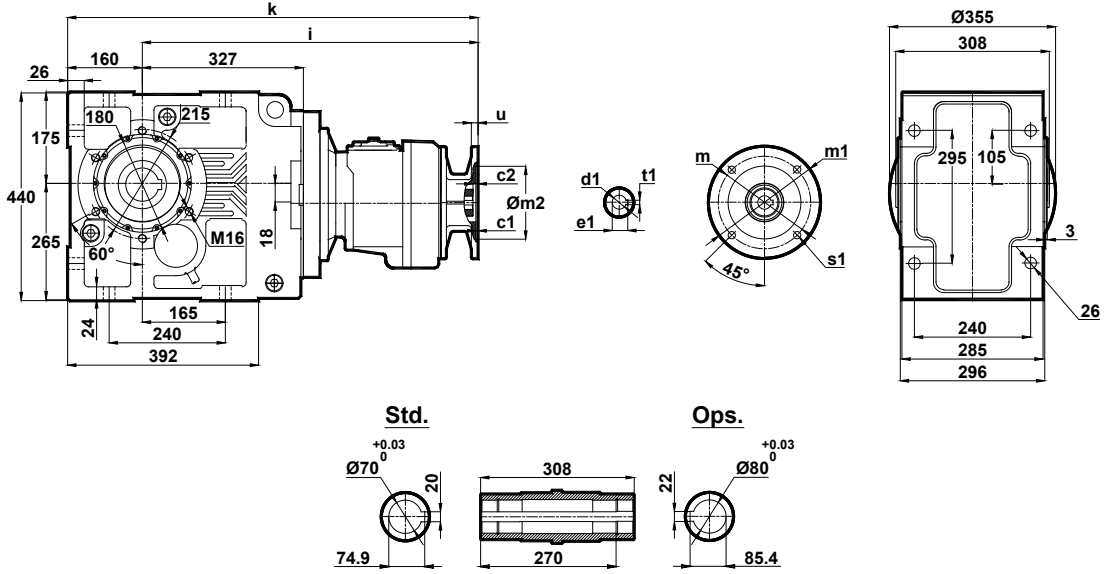

	c1	c2	s1	m	m1	m2	i	u	k	d1	t1	e1
71/B5	4	9	11	130	160	110	636.5	12	796.5	14	5	16.3
80/B5 80/B14	4	9	13 7	165 100	200 120	130 80	636.5	12	796.5	19	6	21.8
90/B5 90/B14	4	9	13 9	165 115	200 140	130 95	636.5	12	796.5	24	8	27.3

KN675.01
KN676.01

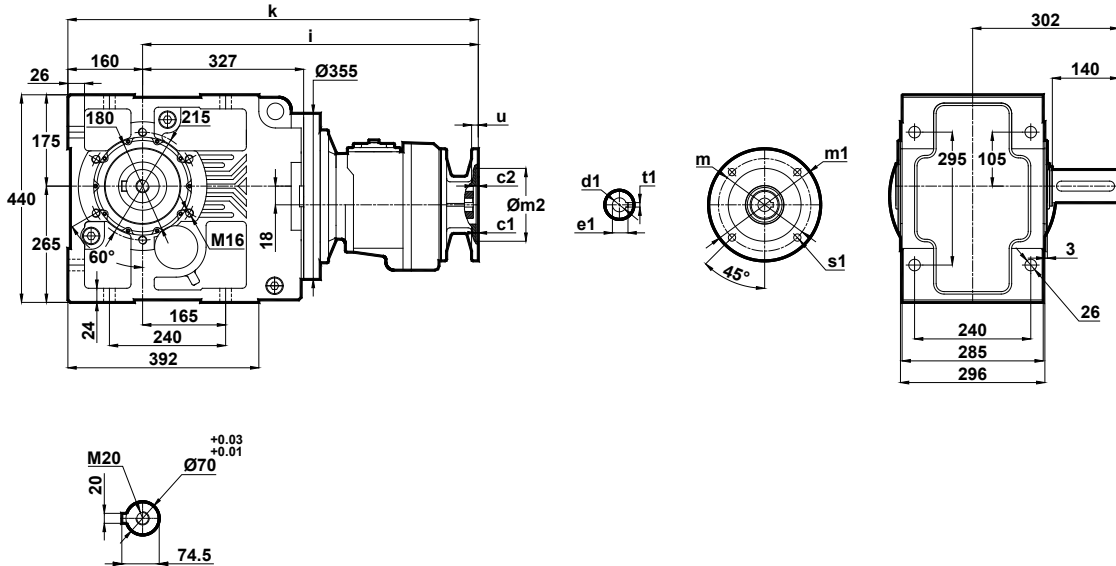

	c1	c2	s1	m	m1	m2	i	u	k	d1	t1	e1
71/B5	4	9	11	130	160	110	636.5	12	796.5	14	5	16.3
80/B5 80/B14	4	9	13 7	165 100	200 120	130 80	636.5	12	796.5	19	6	21.8
90/B5 90/B14	4	9	13 9	165 115	200 140	130 95	636.5	12	796.5	24	8	27.3

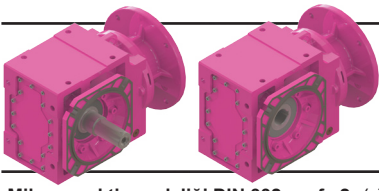

Ölçü Sayfaları

Dimension Pages

Abmessungsseiten

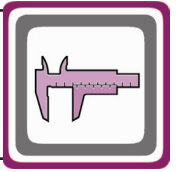

-Mil ucu çektirme deliği DIN 332 sayfa 2 / Tapped center hole to DIN 332, sheet 2 / Zentrierung mit Gewinde DIN 332, Blatt 2

KN675.02
KN676.02

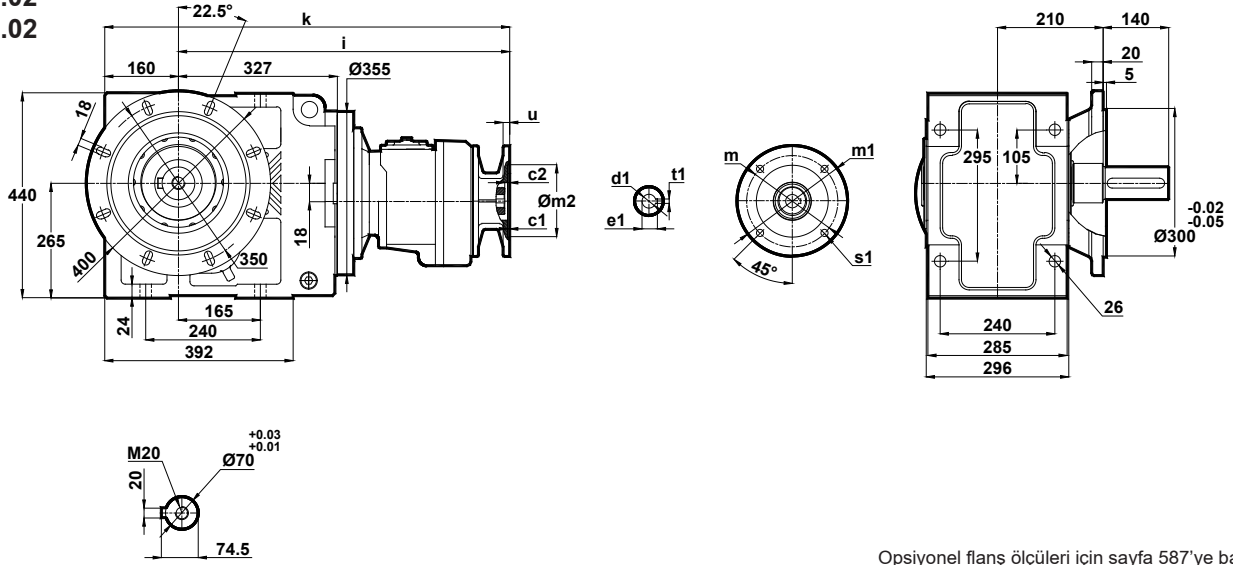

Opsiyonel flanş ölçüleri için sayfa 587'ye bakınız.
Please see on page 587 for optional flange dimensions
Siehe Seite 587 für auswählbare Flanschabmessungen

	c1	c2	s1	m	m1	m2	i	u	k	d1	t1	e1
71/B5	4	9	11	130	160	110	636.5	12	796.5	14	5	16.3
80/B5 80/B14	4	9	13 7	165 100	200 120	130 80	636.5	12	796.5	19	6	21.8
90/B5 90/B14	4	9	13 9	165 115	200 140	130 95	636.5	12	796.5	24	8	27.3

KN675.03
KN676.03

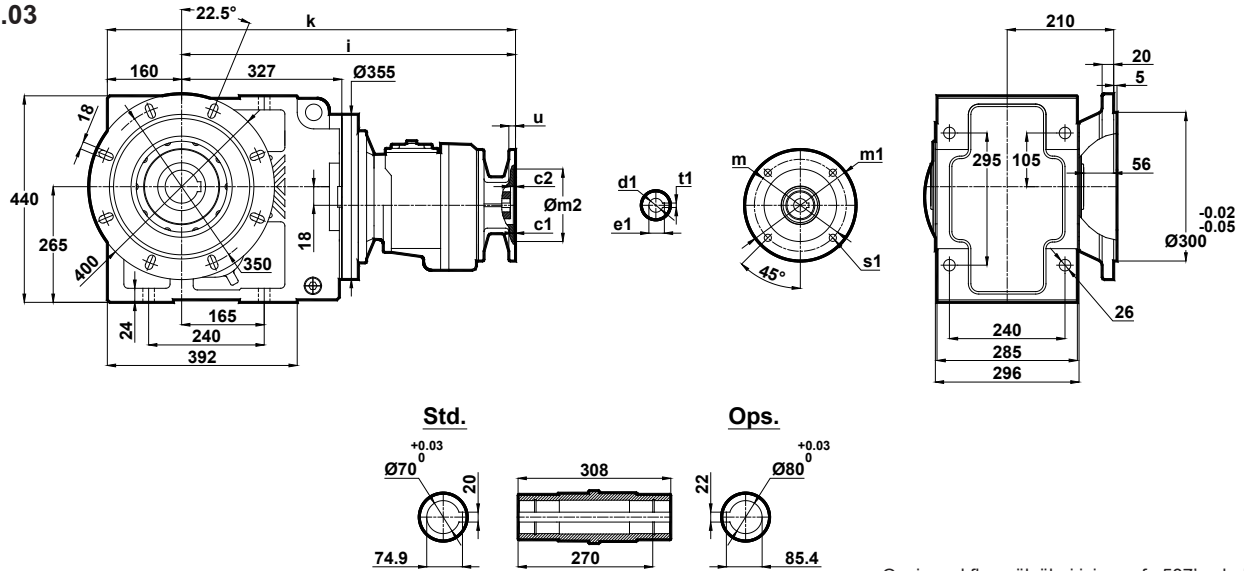

Opsiyonel flanş ölçüleri için sayfa 587'ye bakınız.
Please see on page 587 for optional flange dimensions
Siehe Seite 587 für auswählbare Flanschabmessungen

	c1	c2	s1	m	m1	m2	i	u	k	d1	t1	e1
71/B5	4	9	11	130	160	110	636.5	12	796.5	14	5	16.3
80/B5 80/B14	4	9	13 7	165 100	200 120	130 80	636.5	12	796.5	19	6	21.8
90/B5 90/B14	4	9	13 9	165 115	200 140	130 95	636.5	12	796.5	24	8	27.3

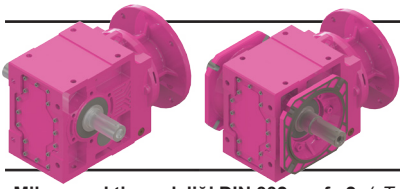

Ölçü Sayfaları

Dimension Pages

Abmessungsseiten

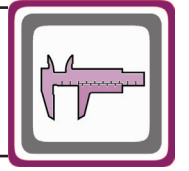

-Mil ucu çektirme deliği DIN 332 sayfa 2 / Tapped center hole to DIN 332, sheet 2 / Zentrierung mit Gewinde DIN 332, Blatt 2

KN675.04
KN676.04

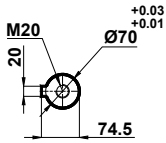
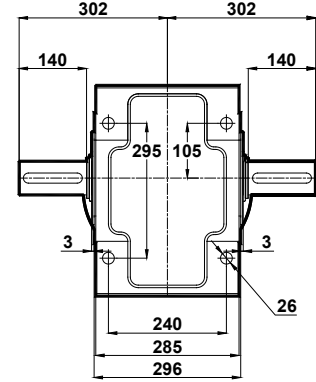
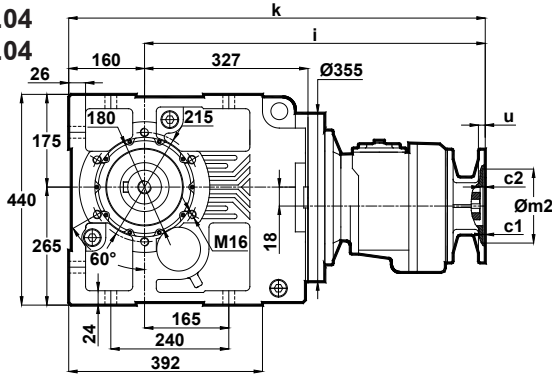

	c1	c2	s1	m	m1	m2	i	u	k	d1	t1	e1
71/B5	4	9	11	130	160	110	636.5	12	796.5	14	5	16.3
80/B5 80/B14	4	9	13 7	165 100	200 120	130 80	636.5	12	796.5	19	6	21.8
90/B5 90/B14	4	9	13 9	165 115	200 140	130 95	636.5	12	796.5	24	8	27.3

KN675.05
KN676.05

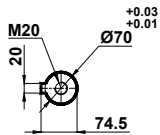
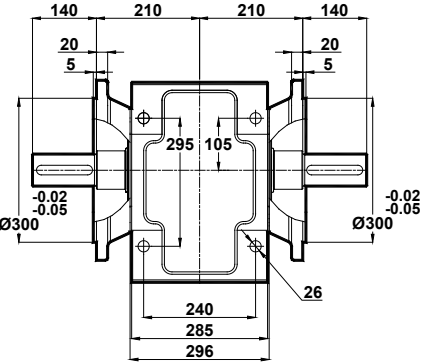
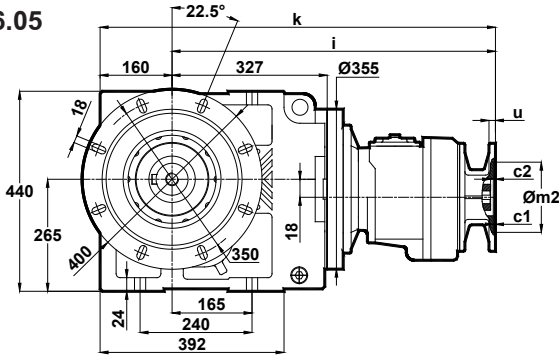

Opsiyonel flanş ölçüleri için sayfa 587'ye bakınız.
Please see on page 587 for optional flange dimensions
Siehe Seite 587 für auswählbare Flanschabmessungen

	c1	c2	s1	m	m1	m2	i	u	k	d1	t1	e1
71/B5	4	9	11	130	160	110	636.5	12	796.5	14	5	16.3
80/B5 80/B14	4	9	13 7	165 100	200 120	130 80	636.5	12	796.5	19	6	21.8
90/B5 90/B14	4	9	13 9	165 115	200 140	130 95	636.5	12	796.5	24	8	27.3

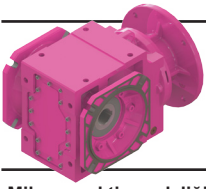

Ölçü Sayfaları Dimension Pages Abmessungsseiten

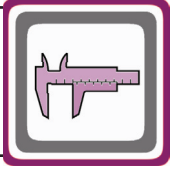

-Mil ucu çekirme deliği DIN 332 sayfa 2 / Tapped center hole to DIN 332, sheet 2 / Zentrierung mit Gewinde DIN 332, Blatt 2

KN675.08
KN676.08

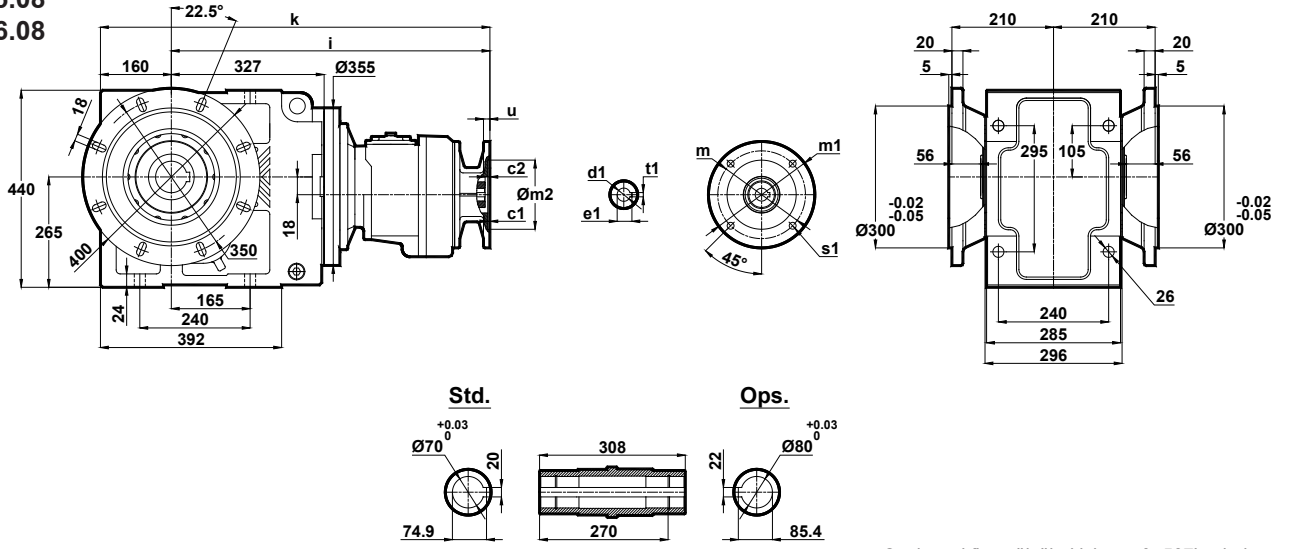

Opsiyonel flanş ölçüleri için sayfa 587'ye bakınız.
Please see on page 587 for optional flange dimensions
Siehe Seite 587 für auswählbare Flanschabmessungen

	c1	c2	s1	m	m1	m2	i	u	k	d1	t1	e1
71/B5	4	9	11	130	160	110	636.5	12	796.5	14	5	16.3
80/B5 80/B14	4	9	13 7	165 100	200 120	130 80	636.5	12	796.5	19	6	21.8
90/B5 90/B14	4	9	13 9	165 115	200 140	130 95	636.5	12	796.5	24	8	27.3

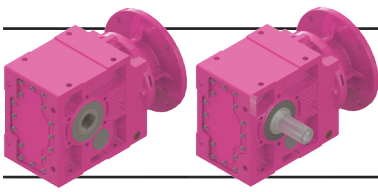

Ölçü Sayfaları

Dimension Pages

Abmessungsseiten

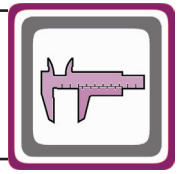

-Mil ucu çekirme deliği DIN 332 sayfa 2 / Tapped center hole to DIN 332, sheet 2 / Zentrierung mit Gewinde DIN 332, Blatt 2

KN773.00

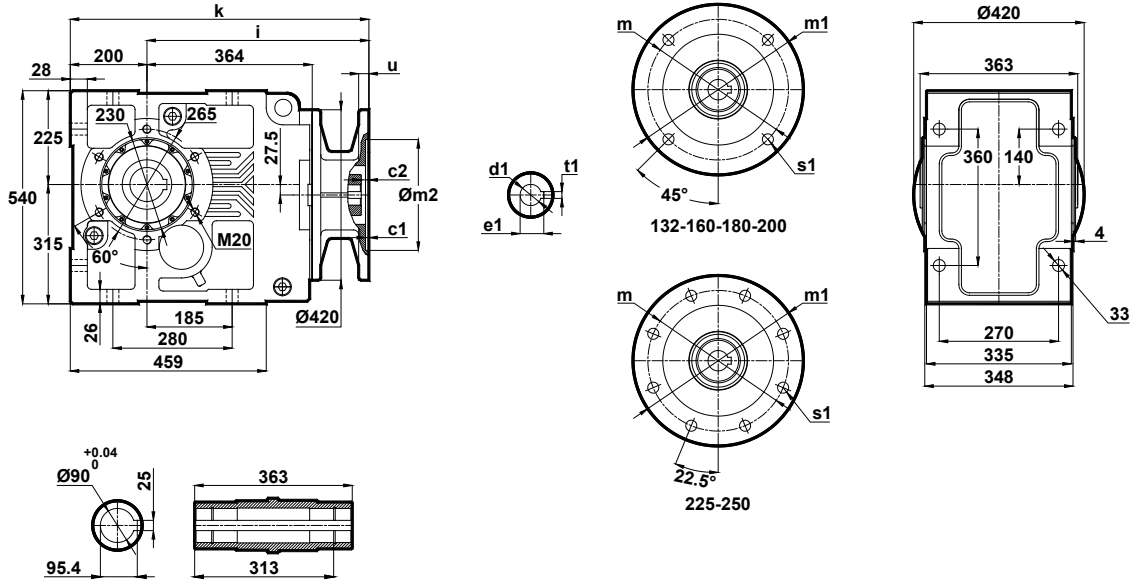

	c1	c2	s1	m	m1	m2	i	u	k	d1	t1	e1
132/B5	4.5	15	15	265	300	230	447.5	15	647.5	38	10	41.3
160/B5	5.5	10	19	300	350	250	517	20	717	42	12	45.3
180/B5	5.5	10	19	300	350	250	517	20	717	48	14	51.8
200/B5	5.5	10	19	350	400	300	539	20	739	55	16	59.3
225/B5	5.5	10	19	400	450	350	592	24	792	60	18	64.4
250/B5	5.5	10	19	500	550	450	592	24	792	65	18	69.4

KN773.01

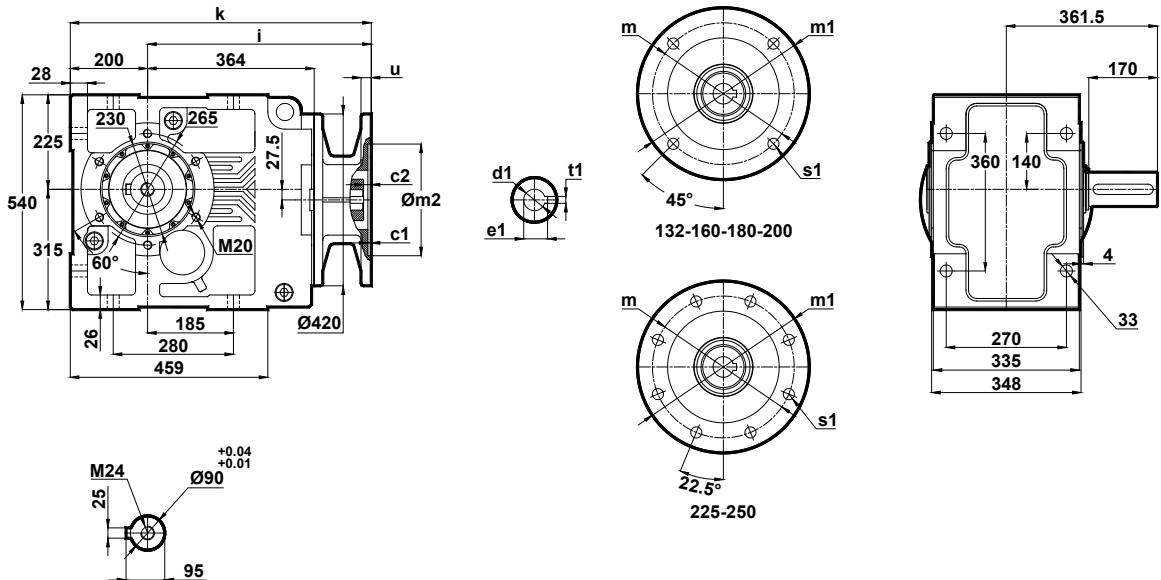

	c1	c2	s1	m	m1	m2	i	u	k	d1	t1	e1
132/B5	4.5	15	15	265	300	230	447.5	15	647.5	38	10	41.3
160/B5	5.5	10	19	300	350	250	517	20	717	42	12	45.3
180/B5	5.5	10	19	300	350	250	517	20	717	48	14	51.8
200/B5	5.5	10	19	350	400	300	539	20	739	55	16	59.3
225/B5	5.5	10	19	400	450	350	592	24	792	60	18	64.4
250/B5	5.5	10	19	500	550	450	592	24	792	65	18	69.4

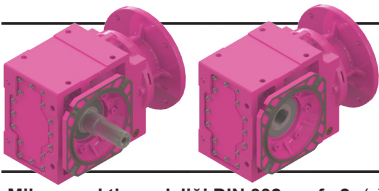

Ölçü Sayfaları Dimension Pages Abmessungsseiten

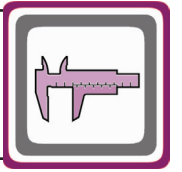

-Mil ucu çekirme deliği DIN 332 sayfa 2 / Tapped center hole to DIN 332, sheet 2 / Zentrierung mit Gewinde DIN 332, Blatt 2

KN773.02

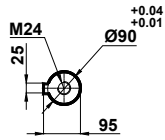
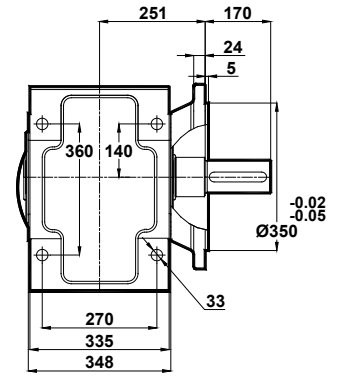
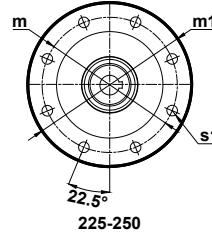
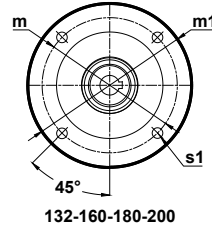
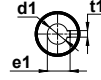
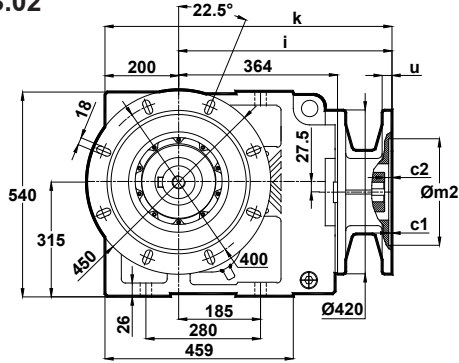

Opsiyonel flanş ölçüleri için sayfa 587'ye bakınız.
Please see on page 587 for optional flange dimensions
Siehe Seite 587 für auswählbare Flanschabmessungen

	c1	c2	s1	m	m1	m2	i	u	k	d1	t1	e1
132/B5	4.5	15	15	265	300	230	447.5	15	647.5	38	10	41.3
160/B5	5.5	10	19	300	350	250	517	20	717	42	12	45.3
180/B5	5.5	10	19	300	350	250	517	20	717	48	14	51.8
200/B5	5.5	10	19	350	400	300	539	20	739	55	16	59.3
225/B5	5.5	10	19	400	450	350	592	24	792	60	18	64.4
250/B5	5.5	10	19	500	550	450	592	24	792	65	18	69.4

KN773.03

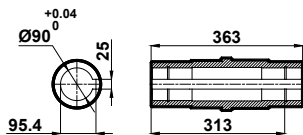
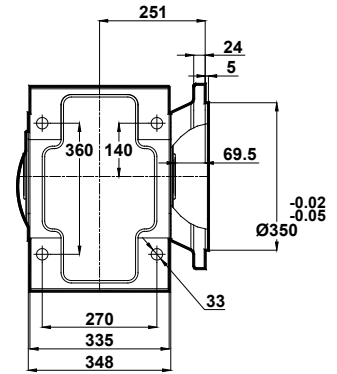
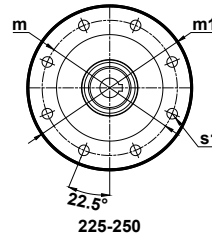
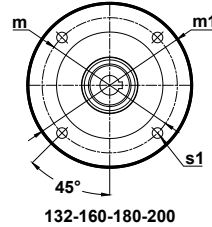
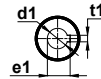
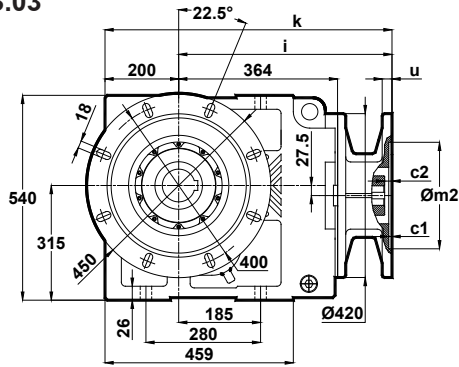

Opsiyonel flanş ölçüleri için sayfa 587'ye bakınız.
Please see on page 587 for optional flange dimensions
Siehe Seite 587 für auswählbare Flanschabmessungen

	c1	c2	s1	m	m1	m2	i	u	k	d1	t1	e1
132/B5	4.5	15	15	265	300	230	447.5	15	647.5	38	10	41.3
160/B5	5.5	10	19	300	350	250	517	20	717	42	12	45.3
180/B5	5.5	10	19	300	350	250	517	20	717	48	14	51.8
200/B5	5.5	10	19	350	400	300	539	20	739	55	16	59.3
225/B5	5.5	10	19	400	450	350	592	24	792	60	18	64.4
250/B5	5.5	10	19	500	550	450	592	24	792	65	18	69.4

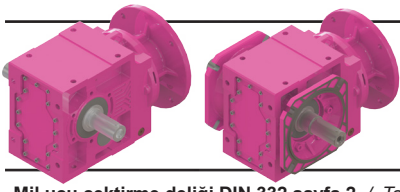

Ölçü Sayfaları

Dimension Pages

Abmessungsseiten

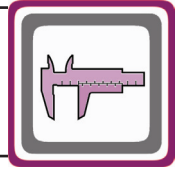

-Mil ucu çektirme deliği DIN 332 sayfa 2 / Tapped center hole to DIN 332, sheet 2 / Zentrierung mit Gewinde DIN 332, Blatt 2

KN773.04

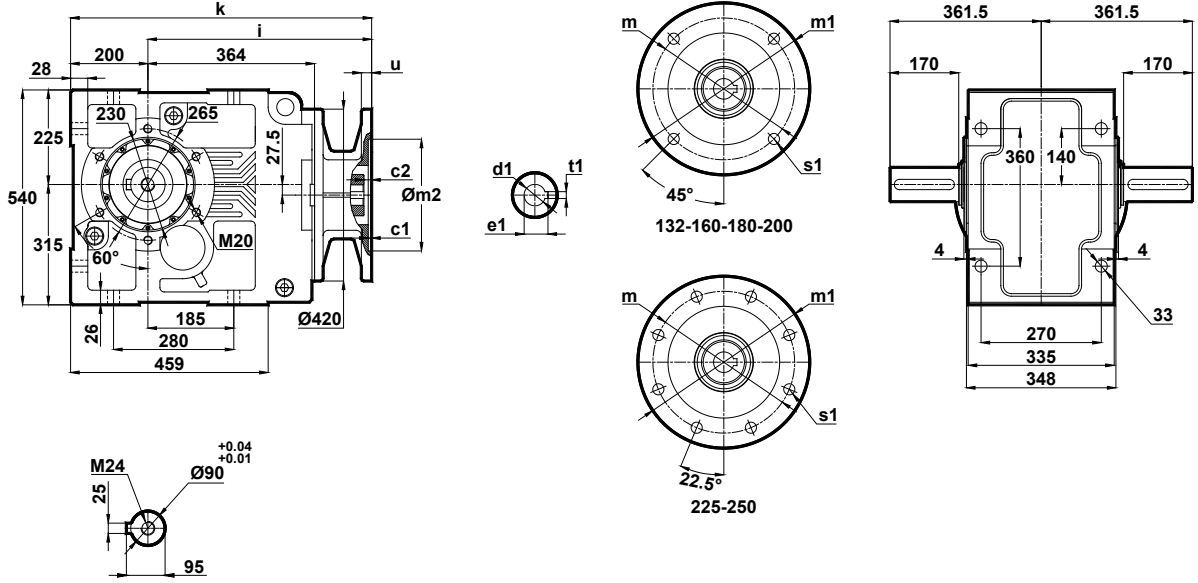

	c1	c2	s1	m	m1	m2	i	u	k	d1	t1	e1
132/B5	4.5	15	15	265	300	230	447.5	15	647.5	38	10	41.3
160/B5	5.5	10	19	300	350	250	517	20	717	42	12	45.3
180/B5	5.5	10	19	300	350	250	517	20	717	48	14	51.8
200/B5	5.5	10	19	350	400	300	539	20	739	55	16	59.3
225/B5	5.5	10	19	400	450	350	592	24	792	60	18	64.4
250/B5	5.5	10	19	500	550	450	592	24	792	65	18	69.4

KN773.05

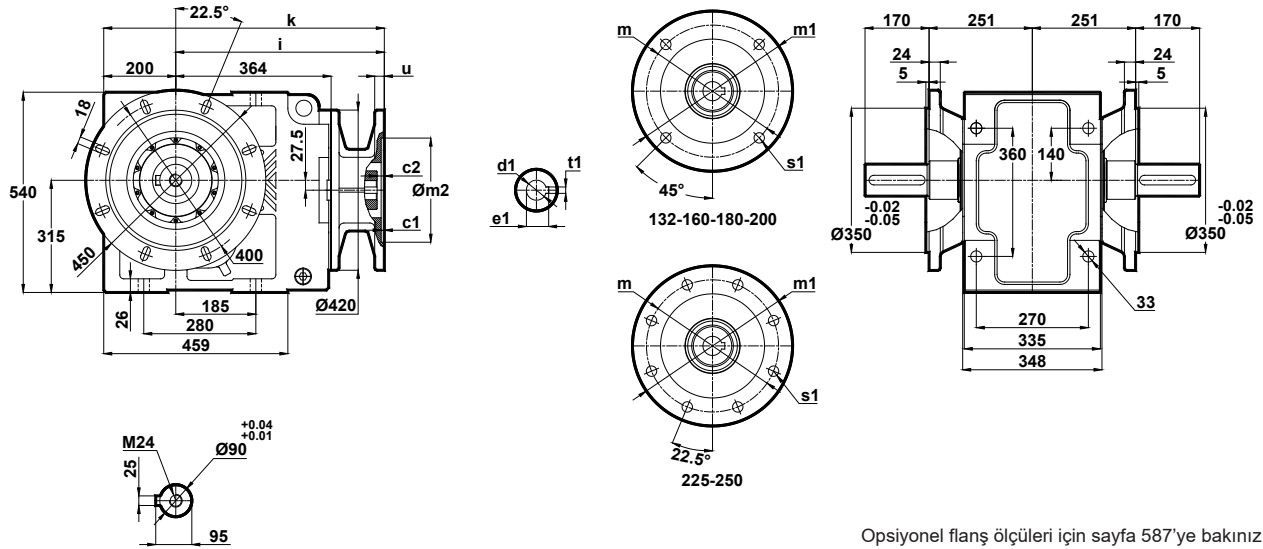

Opsiyonel flanş ölçüleri için sayfa 587'ye bakınız.
Please see on page 587 for optional flange dimensions
Siehe Seite 587 für auswählbare Flanschabmessungen

	c1	c2	s1	m	m1	m2	i	u	k	d1	t1	e1
132/B5	4.5	15	15	265	300	230	447.5	15	647.5	38	10	41.3
160/B5	5.5	10	19	300	350	250	517	20	717	42	12	45.3
180/B5	5.5	10	19	300	350	250	517	20	717	48	14	51.8
200/B5	5.5	10	19	350	400	300	539	20	739	55	16	59.3
225/B5	5.5	10	19	400	450	350	592	24	792	60	18	64.4
250/B5	5.5	10	19	500	550	450	592	24	792	65	18	69.4

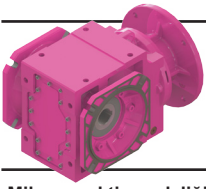

Ölçü Sayfaları Dimension Pages Abmessungenseiten

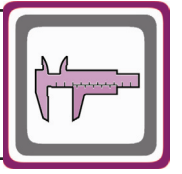

-Mil ucu çekirme deliği DIN 332 sayfa 2 / Tapped center hole to DIN 332, sheet 2 / Zentrierung mit Gewinde DIN 332, Blatt 2

KN773.08

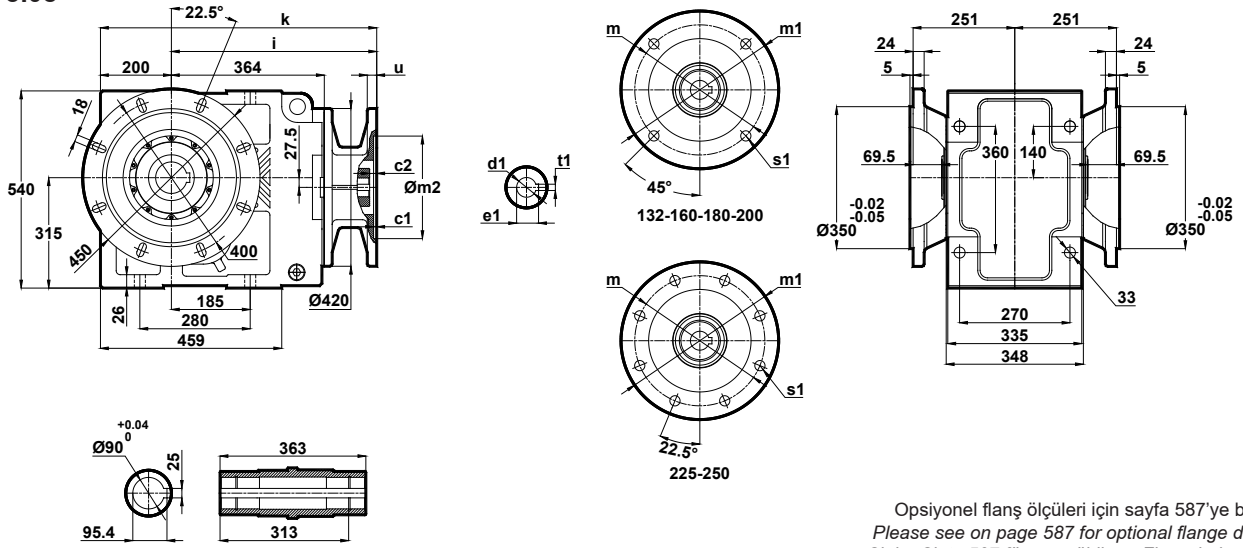

Opsiyonel flanş ölçüleri için sayfa 587'ye bakınız.
Please see on page 587 for optional flange dimensions
Siehe Seite 587 für auswählbare Flanschabmessungen

	c1	c2	s1	m	m1	m2	i	u	k	d1	t1	e1
132/B5	4.5	15	15	265	300	230	447.5	15	647.5	38	10	41.3
160/B5	5.5	10	19	300	350	250	517	20	717	42	12	45.3
180/B5	5.5	10	19	300	350	250	517	20	717	48	14	51.8
200/B5	5.5	10	19	350	400	300	539	20	739	55	16	59.3
225/B5	5.5	10	19	400	450	350	592	24	792	60	18	64.4
250/B5	5.5	10	19	500	550	450	592	24	792	65	18	69.4

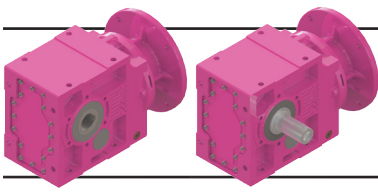

Ölçü Sayfaları

Dimension Pages

Abmessungsseiten

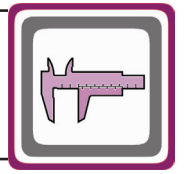

-Mil ucu çekirme deliği DIN 332 sayfa 2 / Tapped center hole to DIN 332, sheet 2 / Zentrierung mit Gewinde DIN 332, Blatt 2

KN774.00

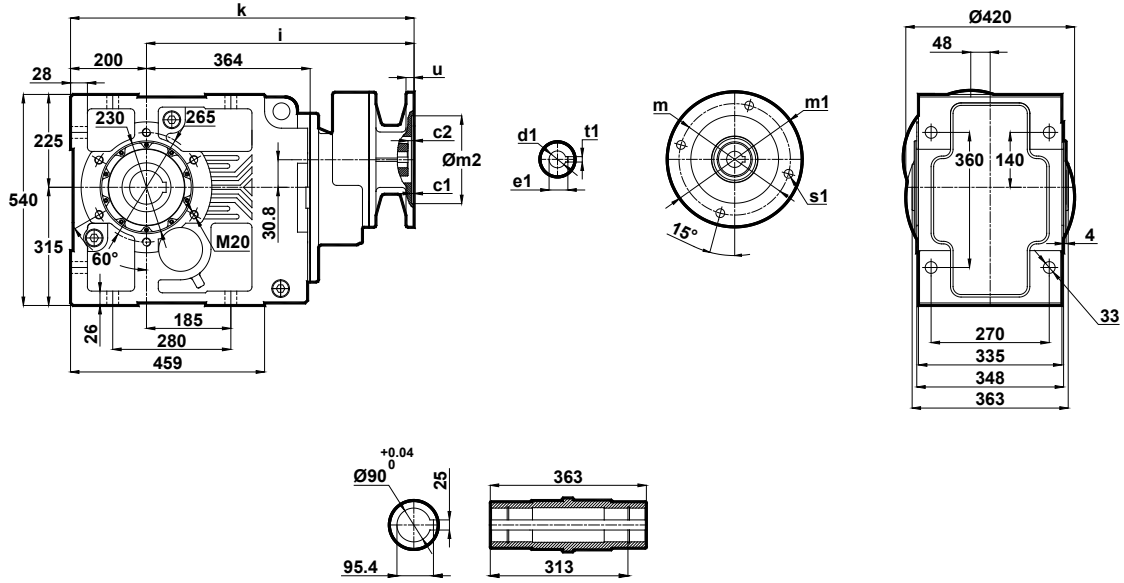

	c1	c2	s1	m	m1	m2	i	u	k	d1	t1	e1
90/B5	4	5	12	165	200	130	522.5	12	722.5	24	8	27.3
90/B14	9	9	9	115	140	95						
100/B5	4.5	9	15	215	250	180	541	15	741	28	8	31.3
100/B14	4	9	9	130	160	110						
112/B5	4.5	9	15	215	250	180	541	15	741	28	8	31.3
112/B14	4	9	9	130	160	110						
132/B5	4.5	6	15	265	300	230	559.5	15	759.5	38	10	41.3
132/B14	4.5	6	11	165	200	130						

KN774.01

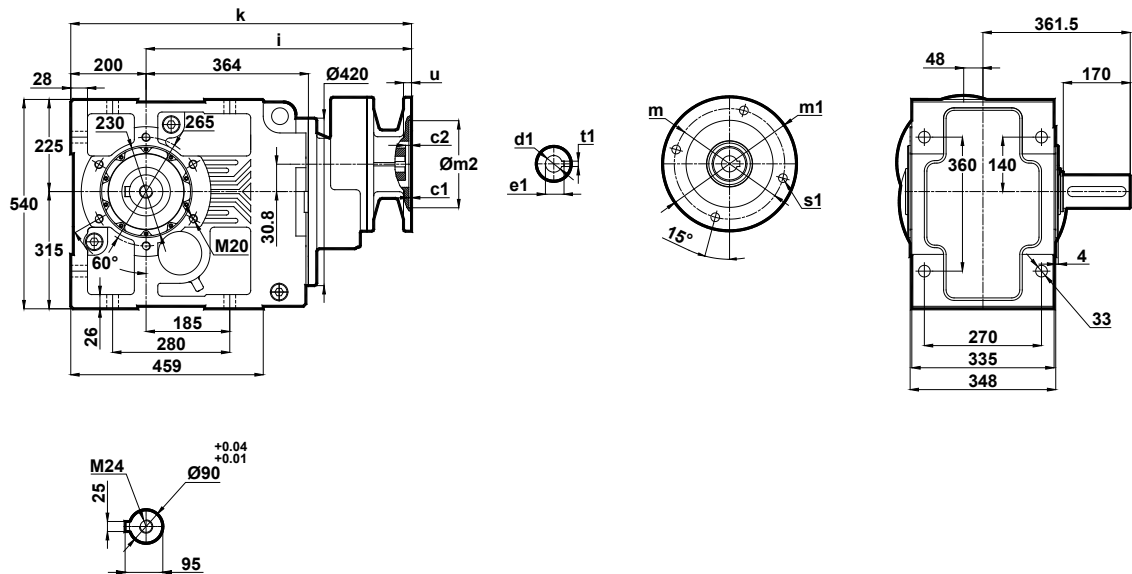

	c1	c2	s1	m	m1	m2	i	u	k	d1	t1	e1
90/B5	4	5	12	165	200	130	522.5	12	722.5	24	8	27.3
90/B14	9	9	9	115	140	95						
100/B5	4.5	9	15	215	250	180	541	15	741	28	8	31.3
100/B14	4	9	9	130	160	110						
112/B5	4.5	9	15	215	250	180	541	15	741	28	8	31.3
112/B14	4	9	9	130	160	110						
132/B5	4.5	6	15	265	300	230	559.5	15	759.5	38	10	41.3
132/B14	4.5	6	11	165	200	130						

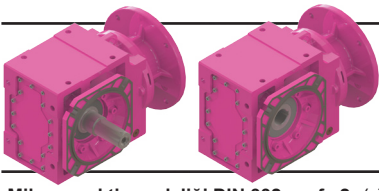

Ölçü Sayfaları

Dimension Pages

Abmessungsseiten

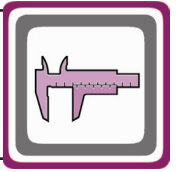

-Mil ucu çektirme deliği DIN 332 sayfa 2 / Tapped center hole to DIN 332, sheet 2 / Zentrierung mit Gewinde DIN 332, Blatt 2

KN774.02

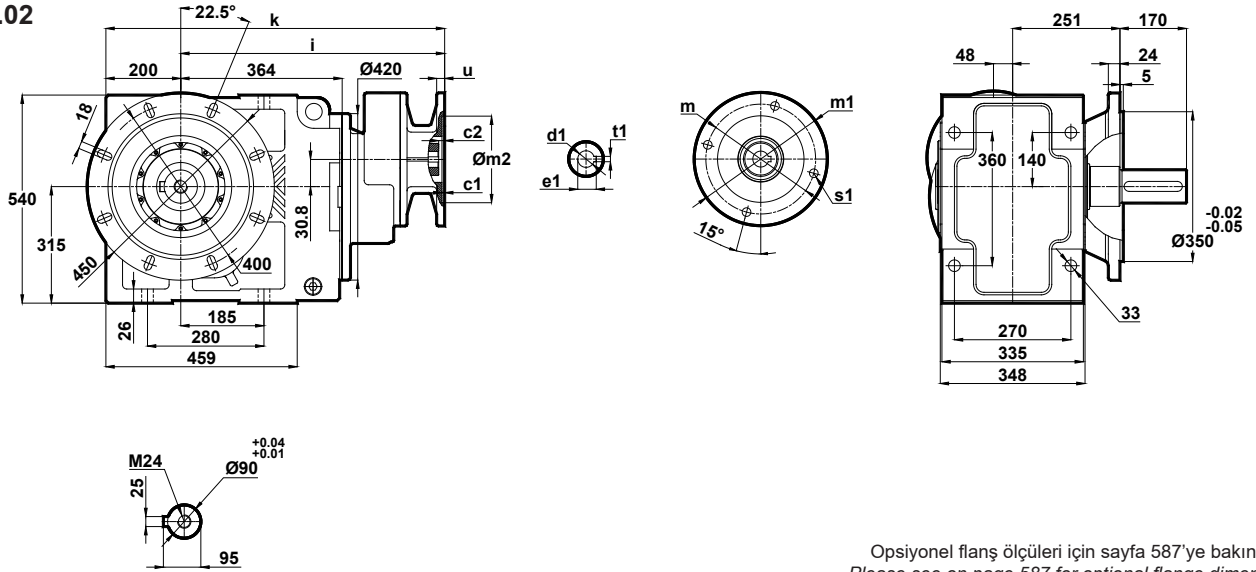

Opsiyonel flanş ölçüleri için sayfa 587'ye bakınız.
Please see on page 587 for optional flange dimensions
Siehe Seite 587 für auswählbare Flanschabmessungen

	c1	c2	s1	m	m1	m2	i	u	k	d1	t1	e1
90/B5	4	5	12	165	200	130	522.5	12	722.5	24	8	27.3
90/B14	9	9	9	115	140	95						
100/B5	4.5	9	15	215	250	180	541	15	741	28	8	31.3
100/B14	4	9	9	130	160	110						
112/B5	4.5	9	15	215	250	180	541	15	741	28	8	31.3
112/B14	4	9	9	130	160	110						
132/B5	4.5	6	15	265	300	230	559.5	15	759.5	38	10	41.3
132/B14	4.5	6	11	165	200	130						

KN774.03

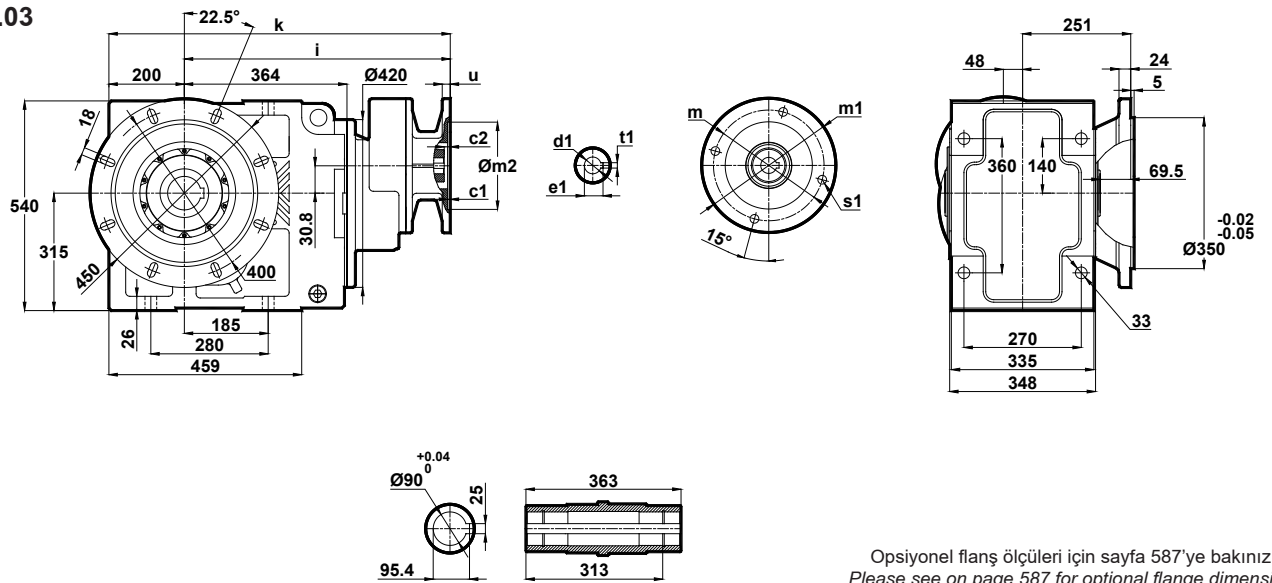

Opsiyonel flanş ölçüleri için sayfa 587'ye bakınız.
Please see on page 587 for optional flange dimensions
Siehe Seite 587 für auswählbare Flanschabmessungen

	c1	c2	s1	m	m1	m2	i	u	k	d1	t1	e1
90/B5	4	5	12	165	200	130	522.5	12	722.5	24	8	27.3
90/B14	9	9	9	115	140	95						
100/B5	4.5	9	15	215	250	180	541	15	741	28	8	31.3
100/B14	4	9	9	130	160	110						
112/B5	4.5	9	15	215	250	180	541	15	741	28	8	31.3
112/B14	4	9	9	130	160	110						
132/B5	4.5	6	15	265	300	230	559.5	15	759.5	38	10	41.3
132/B14	4.5	6	11	165	200	130						

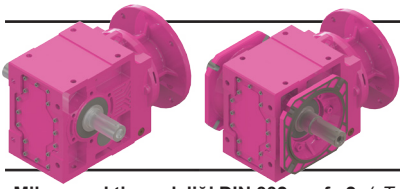

Ölçü Sayfaları Dimension Pages Abmessungsseiten

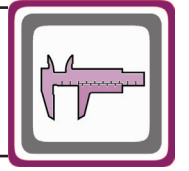

-Mil ucu çektirme deliği DIN 332 sayfa 2 / Tapped center hole to DIN 332, sheet 2 / Zentrierung mit Gewinde DIN 332, Blatt 2

KN774.04

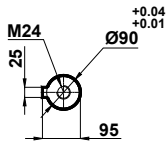
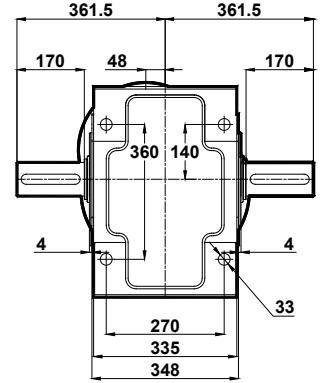
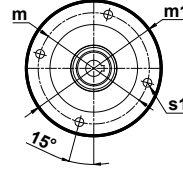
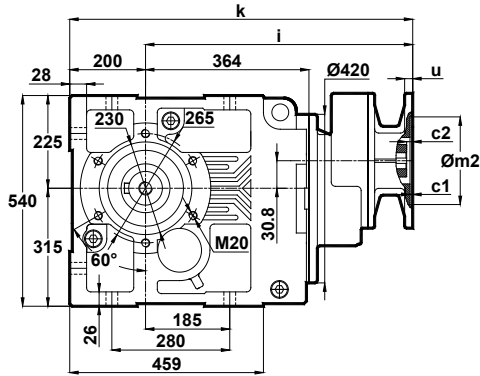

	c1	c2	s1	m	m1	m2	i	u	k	d1	t1	e1
90/B5	4	5	12	165	200	130	522.5	12	722.5	24	8	27.3
90/B14	9	9	9	115	140	95						
100/B5	4.5	9	15	215	250	180	541	15	741	28	8	31.3
100/B14	4	9	9	130	160	110						
112/B5	4.5	9	15	215	250	180	541	15	741	28	8	31.3
112/B14	4	9	9	130	160	110						
132/B5	4.5	6	15	265	300	230	559.5	15	759.5	38	10	41.3
132/B14	4.5	6	11	165	200	130						

KN774.05

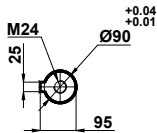
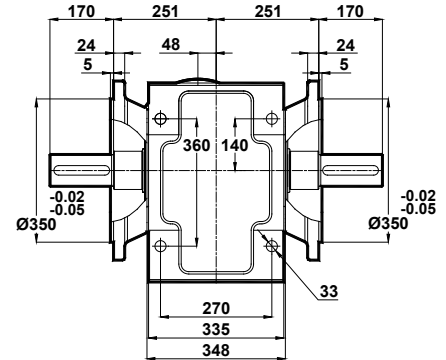
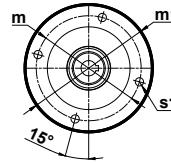
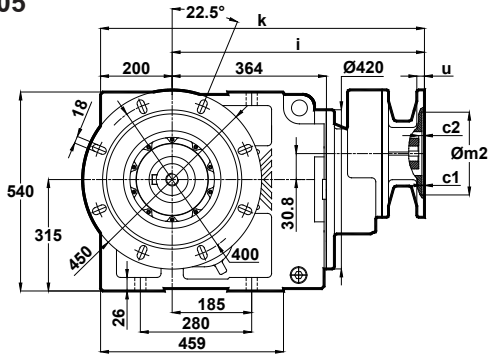

Opsiyonel flanş ölçüleri için sayfa 587'ye bakınız.
Please see on page 587 for optional flange dimensions
Siehe Seite 587 für auswählbare Flanschabmessungen

	c1	c2	s1	m	m1	m2	i	u	k	d1	t1	e1
90/B5	4	5	12	165	200	130	522.5	12	722.5	24	8	27.3
90/B14	9	9	9	115	140	95						
100/B5	4.5	9	15	215	250	180	541	15	741	28	8	31.3
100/B14	4	9	9	130	160	110						
112/B5	4.5	9	15	215	250	180	541	15	741	28	8	31.3
112/B14	4	9	9	130	160	110						
132/B5	4.5	6	15	265	300	230	559.5	15	759.5	38	10	41.3
132/B14	4.5	6	11	165	200	130						

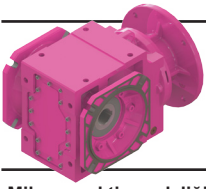

Ölçü Sayfaları Dimension Pages Abmessungsseiten

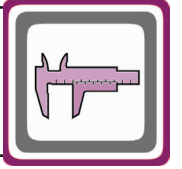

-Mil ucu çektirme deliği DIN 332 sayfa 2 / Tapped center hole to DIN 332, sheet 2 / Zentrierung mit Gewinde DIN 332, Blatt 2

KN774.08

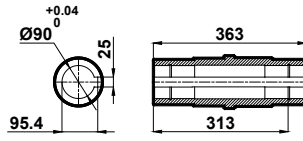
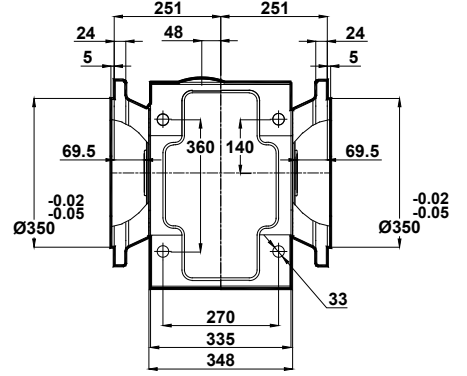
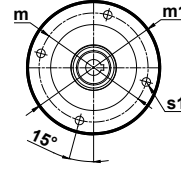
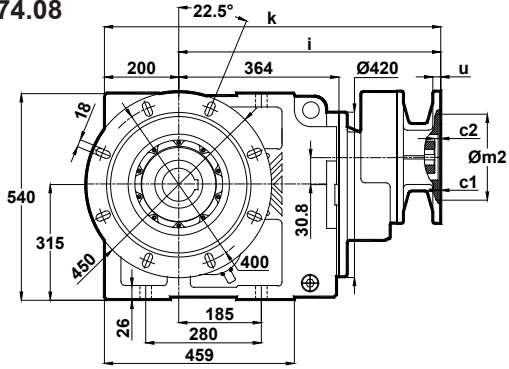

Opsiyonel flanş ölçüleri için sayfa 587'ye bakınız.
Please see on page 587 for optional flange dimensions
Siehe Seite 587 für auswählbare Flanschabmessungen

	c1	c2	s1	m	m1	m2	i	u	k	d1	t1	e1
90/B5	4	5	12	165	200	130	522.5	12	722.5	24	8	27.3
90/B14	4	5	9	115	140	95						
100/B5	4.5	9	15	215	250	180	541	15	741	28	8	31.3
100/B14	4	9	9	130	160	110						
112/B5	4.5	9	15	215	250	180	541	15	741	28	8	31.3
112/B14	4	9	9	130	160	110						
132/B5	4.5	6	15	265	300	230	559.5	15	759.5	38	10	41.3
132/B14	4.5	6	11	165	200	130						

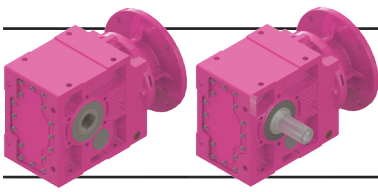

Ölçü Sayfaları

Dimension Pages

Abmessungsseiten

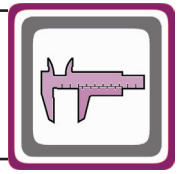

-Mil ucu çektirme deliği DIN 332 sayfa 2 / Tapped center hole to DIN 332, sheet 2 / Zentrierung mit Gewinde DIN 332, Blatt 2

KN775.00
KN776.00

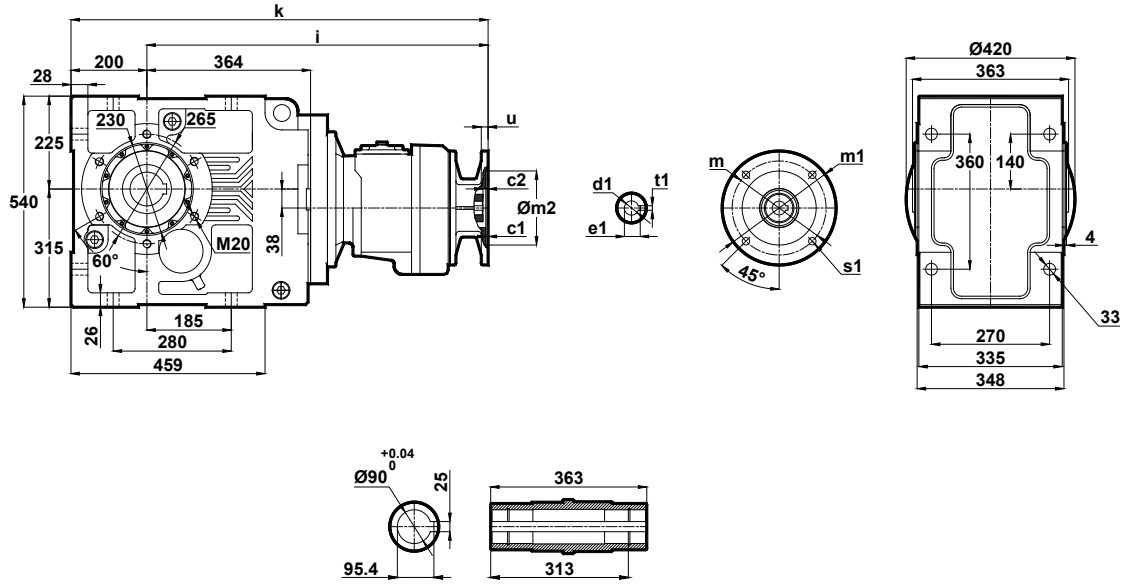

	c1	c2	s1	m	m1	m2	i	u	k	d1	t1	e1
71/B5	4	9	11	130	160	110	673.5	12	873.5	14	5	16.3
80/B5	4	9	12	165	200	130	673.5	12	873.5	19	6	21.8
80/B14	4	9	7	100	120	80	673.5	12	873.5	19	6	21.8
90/B5	4	9	12	165	200	130	673.5	12	873.5	24	8	27.3
90/B14	4	9	9	115	140	90	673.5	12	873.5	24	8	27.3
100/B5	4.5	9	15	215	250	180	690.5	15	890.5	28	8	31.3
100/B14	4	9	9	130	160	110	690.5	15	890.5	28	8	31.3

KN775.01
KN776.01

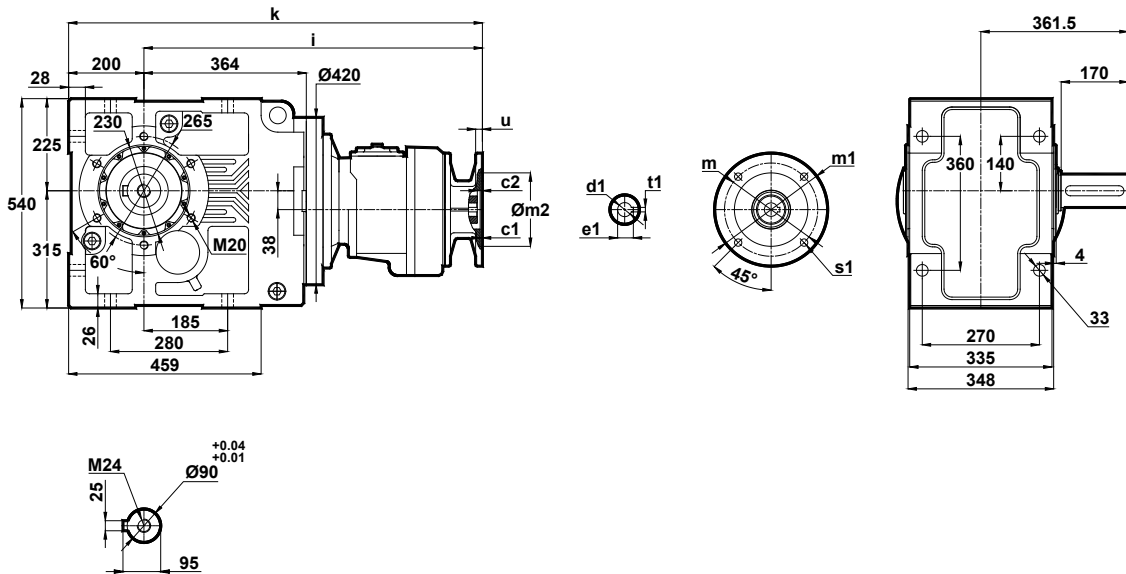

	c1	c2	s1	m	m1	m2	i	u	k	d1	t1	e1
71/B5	4	9	11	130	160	110	673.5	12	873.5	14	5	16.3
80/B5	4	9	12	165	200	130	673.5	12	873.5	19	6	21.8
80/B14	4	9	7	100	120	80	673.5	12	873.5	19	6	21.8
90/B5	4	9	12	165	200	130	673.5	12	873.5	24	8	27.3
90/B14	4	9	9	115	140	90	673.5	12	873.5	24	8	27.3
100/B5	4.5	9	15	215	250	180	690.5	15	890.5	28	8	31.3
100/B14	4	9	9	130	160	110	690.5	15	890.5	28	8	31.3

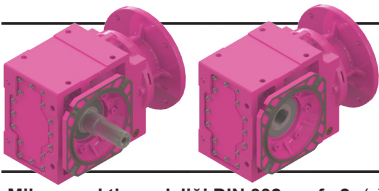

Ölçü Sayfaları Dimension Pages Abmessungsseiten

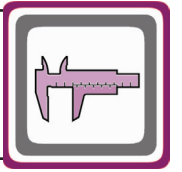

-Mil ucu çektirme deliği DIN 332 sayfa 2 / Tapped center hole to DIN 332, sheet 2 / Zentrierung mit Gewinde DIN 332, Blatt 2

KN775.02
KN776.02

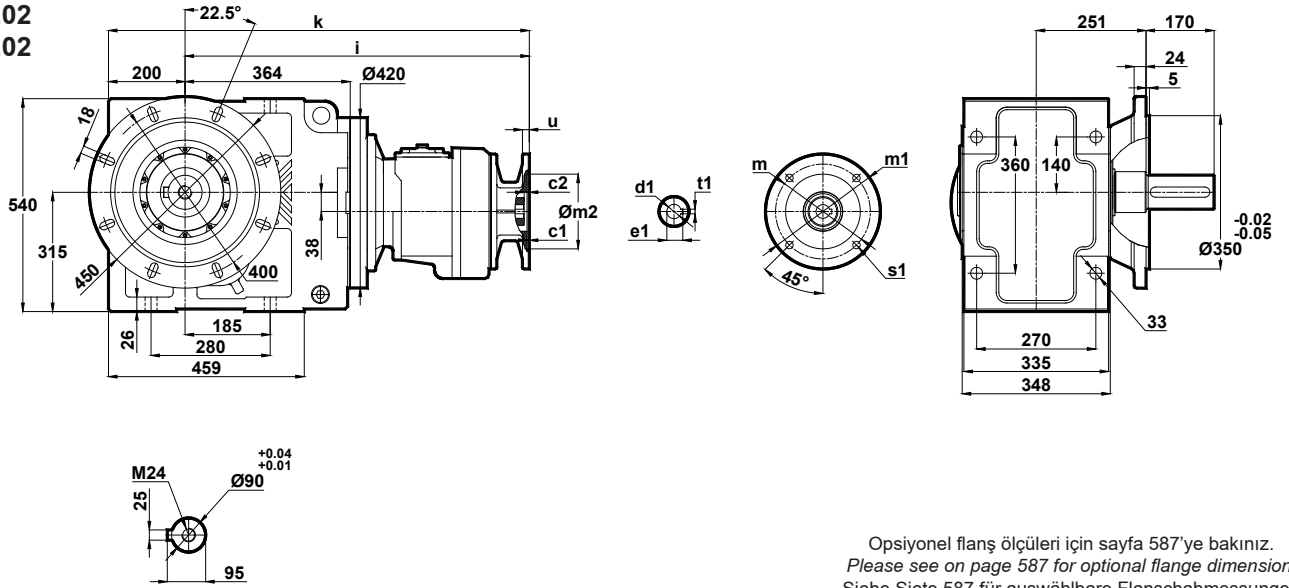

Opsiyonel flanş ölçüleri için sayfa 587'ye bakınız.
Please see on page 587 for optional flange dimensions
Siehe Seite 587 für auswählbare Flanschabmessungen

	c1	c2	s1	m	m1	m2	i	u	k	d1	t1	e1
71/B5	4	9	11	130	160	110	673.5	12	873.5	14	5	16.3
80/B5 80/B14	4	9	12 7	165 100	200 120	130 80	673.5	12	873.5	19	6	21.8
90/B5 90/B14	4	9	12 9	165 115	200 140	130 90	673.5	12	873.5	24	8	27.3
100/B5 100/B14	4.5 4	9	15 9	215 130	250 160	180 110	690.5	15	890.5	28	8	31.3

KN775.03
KN776.03

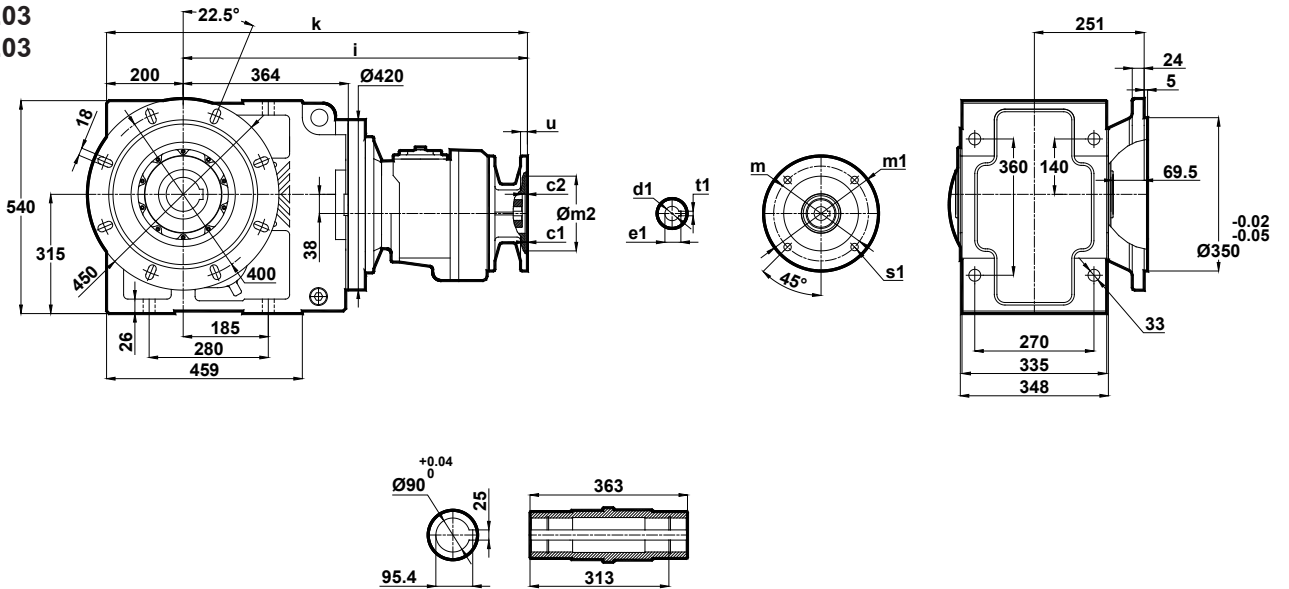

Opsiyonel flanş ölçüleri için sayfa 587'ye bakınız.
Please see on page 587 for optional flange dimensions
Siehe Seite 587 für auswählbare Flanschabmessungen

	c1	c2	s1	m	m1	m2	i	u	k	d1	t1	e1
71/B5	4	9	11	130	160	110	673.5	12	873.5	14	5	16.3
80/B5 80/B14	4	9	12 7	165 100	200 120	130 80	673.5	12	873.5	19	6	21.8
90/B5 90/B14	4	9	12 9	165 115	200 140	130 90	673.5	12	873.5	24	8	27.3
100/B5 100/B14	4.5 4	9	15 9	215 130	250 160	180 110	690.5	15	890.5	28	8	31.3

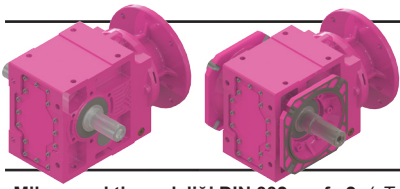

Ölçü Sayfaları

Dimension Pages

Abmessungsseiten

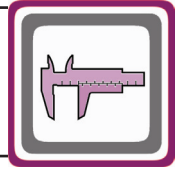

-Mil ucu çekirme deliği DIN 332 sayfa 2 / Tapped center hole to DIN 332, sheet 2 / Zentrierung mit Gewinde DIN 332, Blatt 2

KN775.04
KN776.04

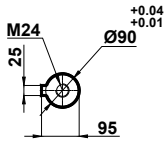
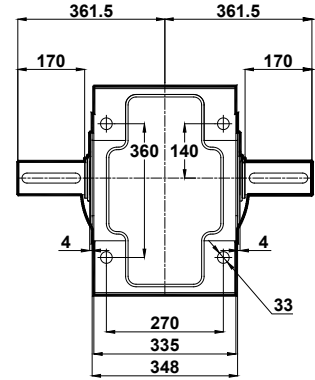
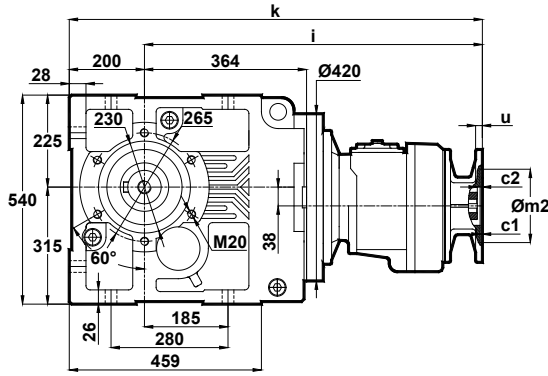

	c1	c2	s1	m	m1	m2	i	u	k	d1	t1	e1
71/B5	4	9	11	130	160	110	673.5	12	873.5	14	5	16.3
80/B5	4	9	12	165	200	130	673.5	12	873.5	19	6	21.8
80/B14	4	9	7	100	120	80	673.5	12	873.5	19	6	21.8
90/B5	4	9	12	165	200	130	673.5	12	873.5	24	8	27.3
90/B14	4	9	9	115	140	90	673.5	12	873.5	24	8	27.3
100/B5	4.5	9	15	215	250	180	690.5	15	890.5	28	8	31.3
100/B14	4	9	9	130	160	110	690.5	15	890.5	28	8	31.3

KN775.05
KN776.05

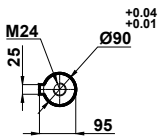
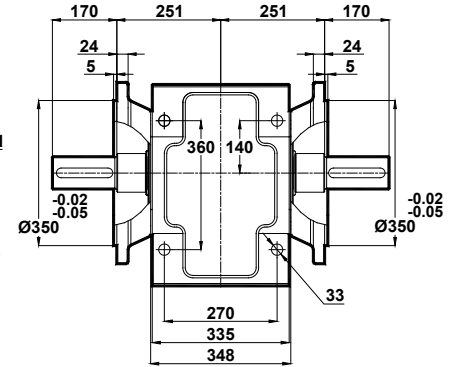
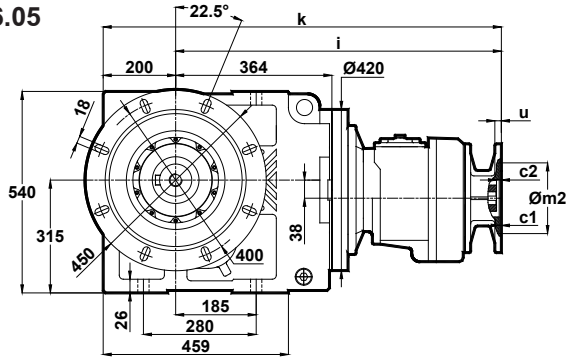

Opsiyonel flanş ölçüleri için sayfa 587'ye bakınız.
Please see on page 587 for optional flange dimensions
Siehe Seite 587 für auswählbare Flanschabmessungen

	c1	c2	s1	m	m1	m2	i	u	k	d1	t1	e1
71/B5	4	9	11	130	160	110	673.5	12	873.5	14	5	16.3
80/B5	4	9	12	165	200	130	673.5	12	873.5	19	6	21.8
80/B14	4	9	7	100	120	80	673.5	12	873.5	19	6	21.8
90/B5	4	9	12	165	200	130	673.5	12	873.5	24	8	27.3
90/B14	4	9	9	115	140	90	673.5	12	873.5	24	8	27.3
100/B5	4.5	9	15	215	250	180	690.5	15	890.5	28	8	31.3
100/B14	4	9	9	130	160	110	690.5	15	890.5	28	8	31.3

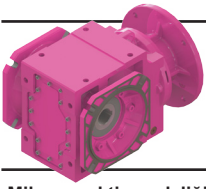

Ölçü Sayfaları Dimension Pages Abmessungenseiten

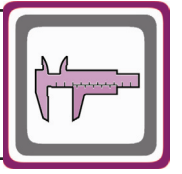

-Mil ucu çekirme deliği DIN 332 sayfa 2 / Tapped center hole to DIN 332, sheet 2 / Zentrierung mit Gewinde DIN 332, Blatt 2

KN775.08
KN776.08

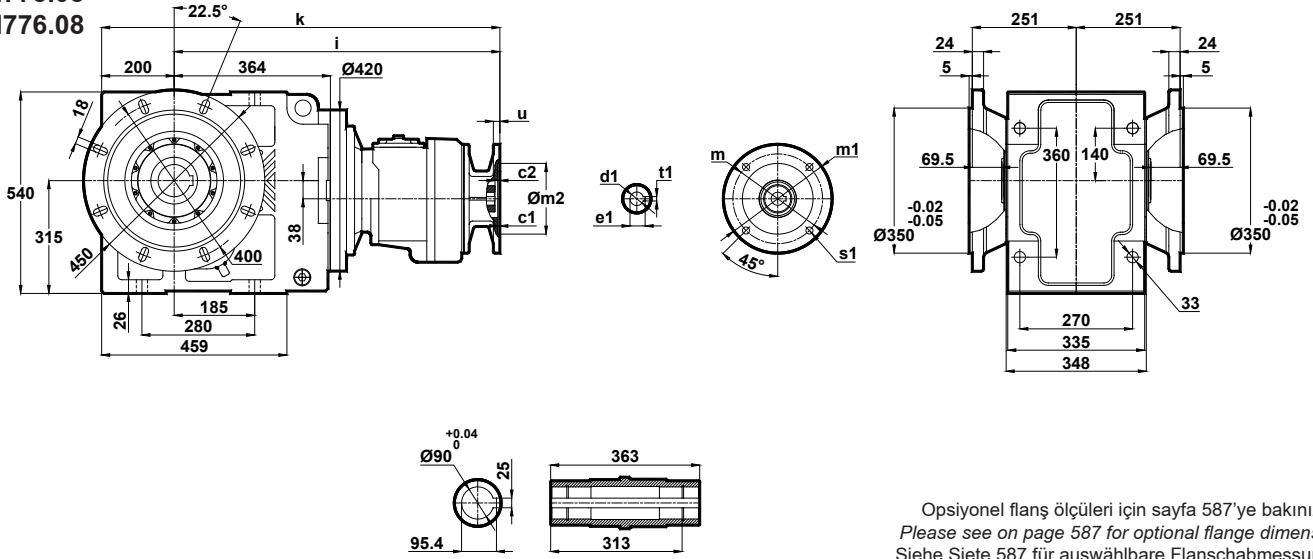

Opsiyonel flanş ölçüleri için sayfa 587'ye bakınız.
Please see on page 587 for optional flange dimensions
Siehe Seite 587 für auswählbare Flanschabmessungen

	c1	c2	s1	m	m1	m2	i	u	k	d1	t1	e1
71/B5	4	9	11	130	160	110	673.5	12	873.5	14	5	16.3
80/B5 80/B14	4	9	12 7	165 100	200 120	130 80	673.5	12	873.5	19	6	21.8
90/B5 90/B14	4	9	12 9	165 115	200 140	130 90	673.5	12	873.5	24	8	27.3
100/B5 100/B14	4.5 4	9	15 9	215 130	250 160	180 110	690.5	15	890.5	28	8	31.3

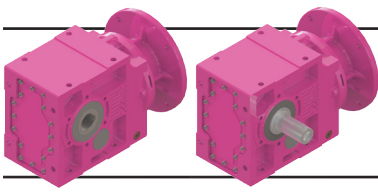

Ölçü Sayfaları

Dimension Pages

Abmessungsseiten

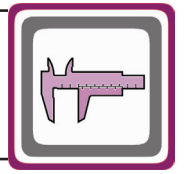

-Mil ucu çekirme deliği DIN 332 sayfa 2 / Tapped center hole to DIN 332, sheet 2 / Zentrierung mit Gewinde DIN 332, Blatt 2

KN873.00

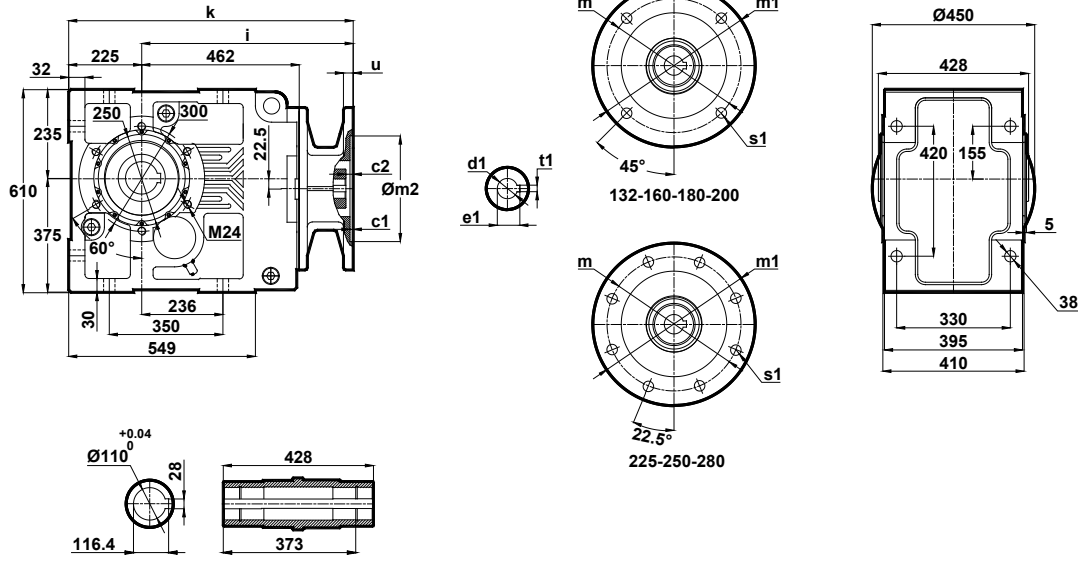

	c1	c2	s1	m	m1	m2	i	u	k	d1	t1	e1
132/B5	4.5	14	15	265	300	230	532.5	15	757.5	38	10	41.3
160/B5	5.5	10	19	300	350	250	680	20	905	42	12	45.3
180/B5	5.5	10	19	300	350	250	680	20	905	48	14	51.8
200/B5	5.5	10	19	350	400	300	680	22	905	55	16	59.3
225/B5	5.5	10	19	400	450	350	680	24	905	60	18	64.4
250/B5	5.5	10	19	500	550	450	680	24	905	65	18	69.4
280/B5	5.5	10	19	500	550	450	680	24	905	75	20	79.9

KN873.01

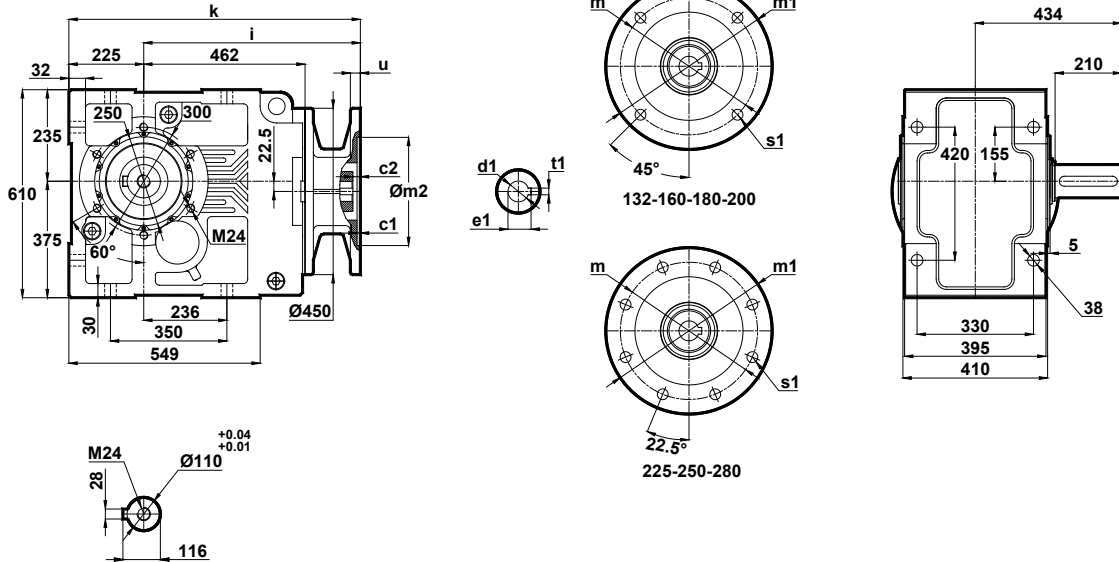

	c1	c2	s1	m	m1	m2	i	u	k	d1	t1	e1
132/B5	4.5	14	15	265	300	230	532.5	15	757.5	38	10	41.3
160/B5	5.5	10	19	300	350	250	680	20	905	42	12	45.3
180/B5	5.5	10	19	300	350	250	680	20	905	48	14	51.8
200/B5	5.5	10	19	350	400	300	680	22	905	55	16	59.3
225/B5	5.5	10	19	400	450	350	680	24	905	60	18	64.4
250/B5	5.5	10	19	500	550	450	680	24	905	65	18	69.4
280/B5	5.5	10	19	500	550	450	680	24	905	75	20	79.9

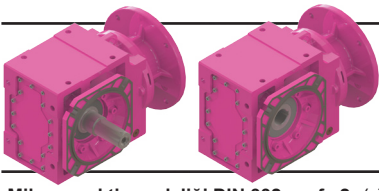

Ölçü Sayfaları Dimension Pages Abmessungsseiten

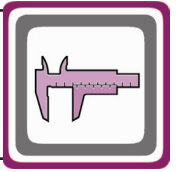

-Mil ucu çektirme deliği DIN 332 sayfa 2 / Tapped center hole to DIN 332, sheet 2 / Zentrierung mit Gewinde DIN 332, Blatt 2

KN873.02

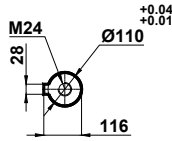
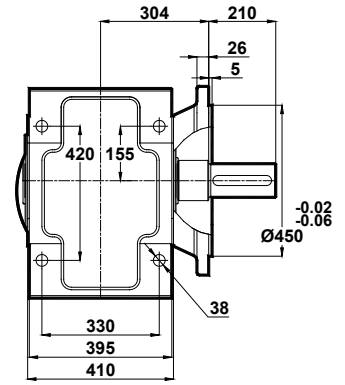
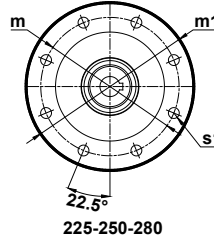
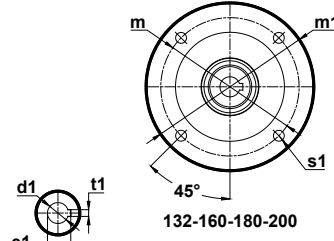
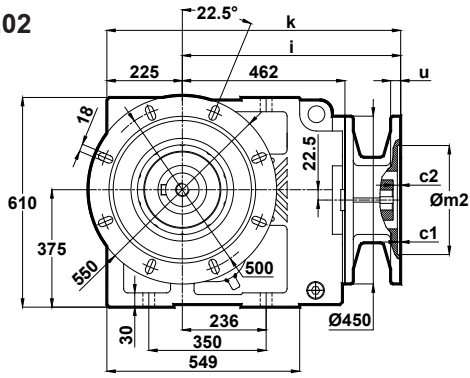

Opsiyonel flanş ölçüleri için sayfa 587'ye bakınız.
Please see on page 587 for optional flange dimensions
Siehe Seite 587 für auswählbare Flanschabmessungen

	c1	c2	s1	m	m1	m2	i	u	k	d1	t1	e1
132/B5	4.5	14	15	265	300	230	532.5	15	757.5	38	10	41.3
160/B5	5.5	10	19	300	350	250	680	20	905	42	12	45.3
180/B5	5.5	10	19	300	350	250	680	20	905	48	14	51.8
200/B5	5.5	10	19	350	400	300	680	22	905	55	16	59.3
225/B5	5.5	10	19	400	450	350	680	24	905	60	18	64.4
250/B5	5.5	10	19	500	550	450	680	24	905	65	18	69.4
280/B5	5.5	10	19	500	550	450	680	24	905	75	20	79.9

KN873.03

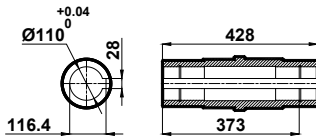
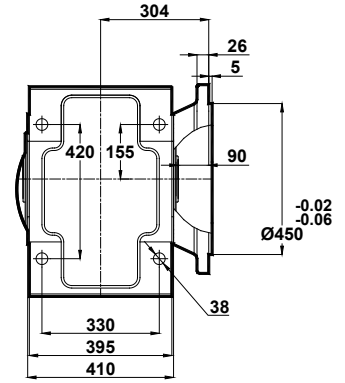
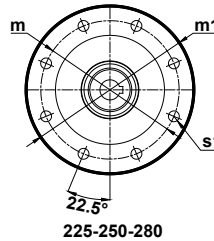
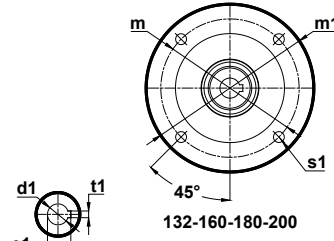
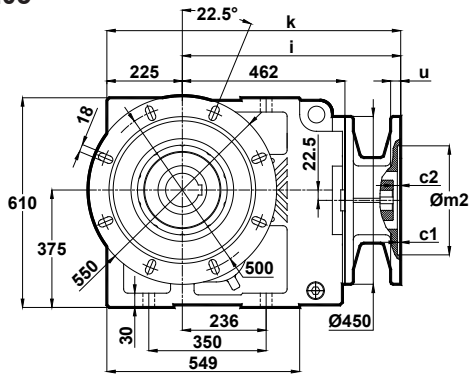

Opsiyonel flanş ölçüleri için sayfa 587'ye bakınız.
Please see on page 587 for optional flange dimensions
Siehe Seite 587 für auswählbare Flanschabmessungen

	c1	c2	s1	m	m1	m2	i	u	k	d1	t1	e1
132/B5	4.5	14	15	265	300	230	532.5	15	757.5	38	10	41.3
160/B5	5.5	10	19	300	350	250	680	20	905	42	12	45.3
180/B5	5.5	10	19	300	350	250	680	20	905	48	14	51.8
200/B5	5.5	10	19	350	400	300	680	22	905	55	16	59.3
225/B5	5.5	10	19	400	450	350	680	24	905	60	18	64.4
250/B5	5.5	10	19	500	550	450	680	24	905	65	18	69.4
280/B5	5.5	10	19	500	550	450	680	24	905	75	20	79.9

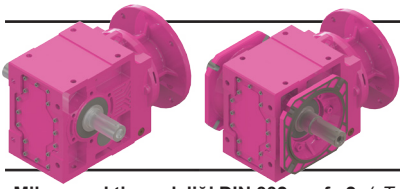

Ölçü Sayfaları Dimension Pages Abmessungsseiten

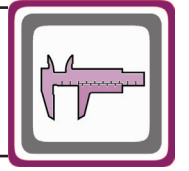

-Mil ucu çektirme deliği DIN 332 sayfa 2 / Tapped center hole to DIN 332, sheet 2 / Zentrierung mit Gewinde DIN 332, Blatt 2

KN873.04

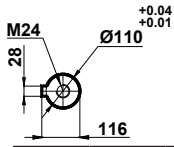
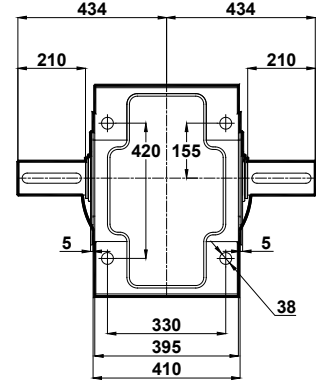
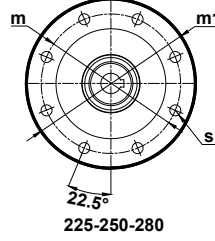
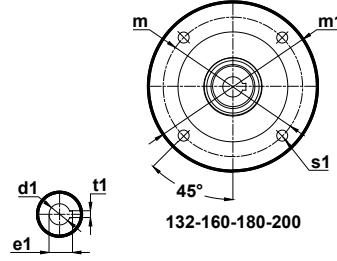
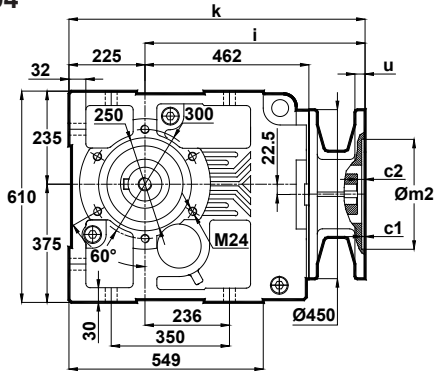

	c1	c2	s1	m	m1	m2	i	u	k	d1	t1	e1
132/B5	4.5	14	15	265	300	230	532.5	15	757.5	38	10	41.3
160/B5	5.5	10	19	300	350	250	680	20	905	42	12	45.3
180/B5	5.5	10	19	300	350	250	680	20	905	48	14	51.8
200/B5	5.5	10	19	350	400	300	680	22	905	55	16	59.3
225/B5	5.5	10	19	400	450	350	680	24	905	60	18	64.4
250/B5	5.5	10	19	500	550	450	680	24	905	65	18	69.4
280/B5	5.5	10	19	500	550	450	680	24	905	75	20	79.9

KN873.05

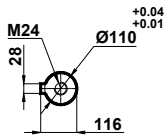
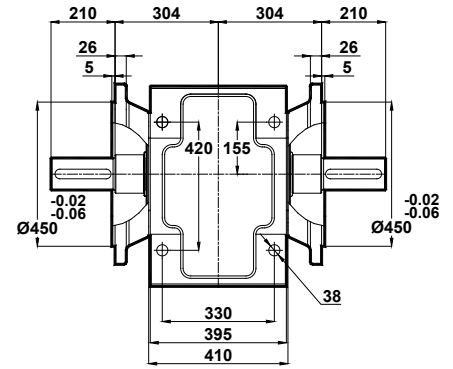
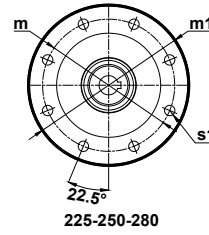
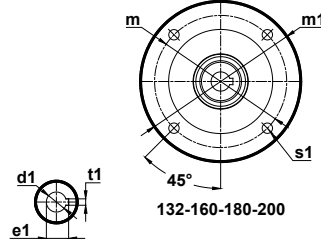
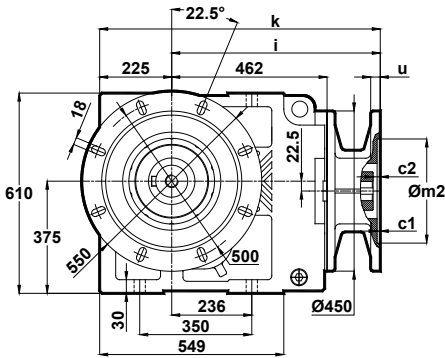

Opsiyonel flanş ölçüleri için sayfa 587'ye bakınız.
Please see on page 587 for optional flange dimensions
Siehe Seite 587 für auswählbare Flanschabmessungen

	c1	c2	s1	m	m1	m2	i	u	k	d1	t1	e1
132/B5	4.5	14	15	265	300	230	532.5	15	757.5	38	10	41.3
160/B5	5.5	10	19	300	350	250	680	20	905	42	12	45.3
180/B5	5.5	10	19	300	350	250	680	20	905	48	14	51.8
200/B5	5.5	10	19	350	400	300	680	22	905	55	16	59.3
225/B5	5.5	10	19	400	450	350	680	24	905	60	18	64.4
250/B5	5.5	10	19	500	550	450	680	24	905	65	18	69.4
280/B5	5.5	10	19	500	550	450	680	24	905	75	20	79.9

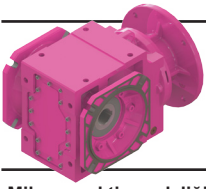

Ölçü Sayfaları Dimension Pages Abmessungenseiten

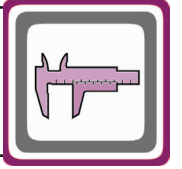

-Mil ucu çekirme deliği DIN 332 sayfa 2 / Tapped center hole to DIN 332, sheet 2 / Zentrierung mit Gewinde DIN 332, Blatt 2

KN873.08

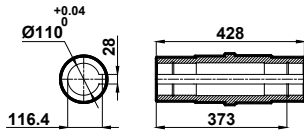
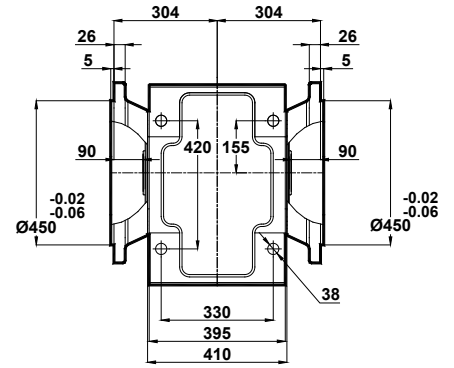
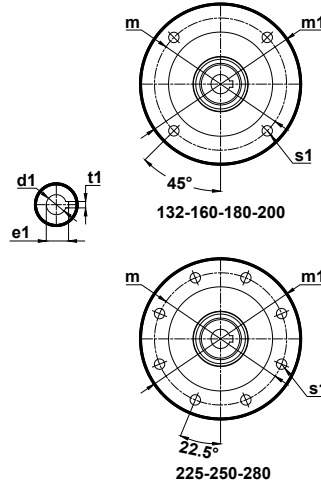
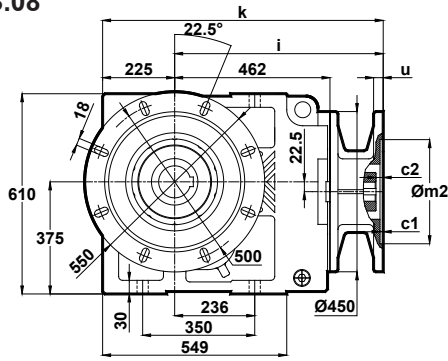

Opsiyonel flanş ölçüleri için sayfa 587'ye bakınız.
Please see on page 587 for optional flange dimensions
Siehe Seite 587 für auswählbare Flanschabmessungen

	c1	c2	s1	m	m1	m2	i	u	k	d1	t1	e1
132/B5	4.5	14	15	265	300	230	532.5	15	757.5	38	10	41.3
160/B5	5.5	10	19	300	350	250	680	20	905	42	12	45.3
180/B5	5.5	10	19	300	350	250	680	20	905	48	14	51.8
200/B5	5.5	10	19	350	400	300	680	22	905	55	16	59.3
225/B5	5.5	10	19	400	450	350	680	24	905	60	18	64.4
250/B5	5.5	10	19	500	550	450	680	24	905	65	18	69.4
280/B5	5.5	10	19	500	550	450	680	24	905	75	20	79.9

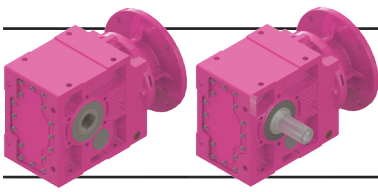

Ölçü Sayfaları

Dimension Pages

Abmessungsseiten

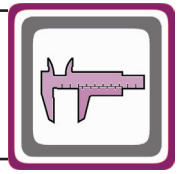

-Mil ucu çekirme deliği DIN 332 sayfa 2 / Tapped center hole to DIN 332, sheet 2 / Zentrierung mit Gewinde DIN 332, Blatt 2

KN874.00

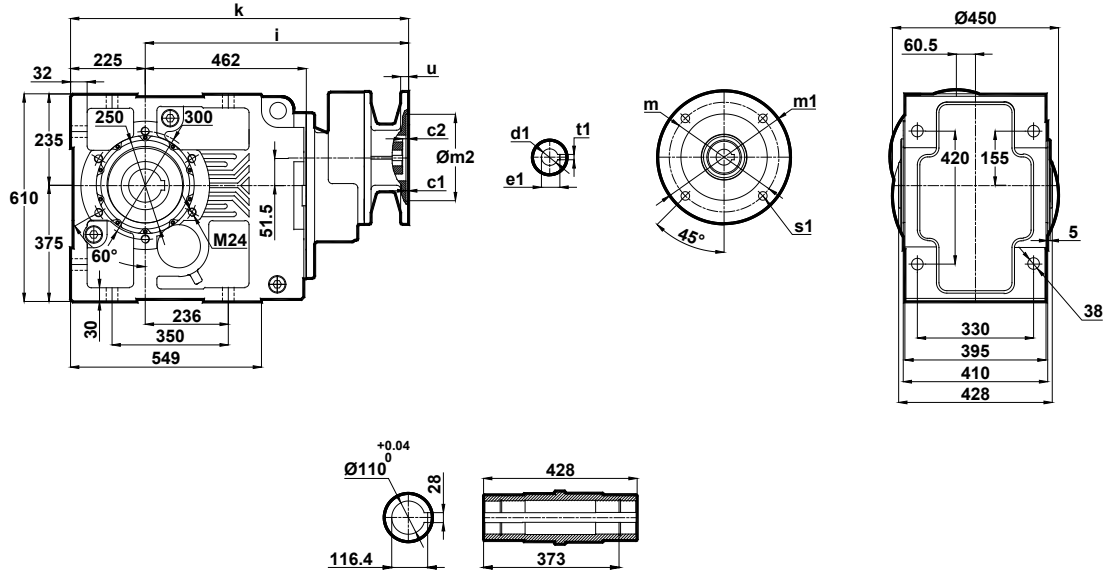

	c1	c2	s1	m	m1	m2	i	u	k	d1	t1	e1
100/B5	4.5	9	15	215	250	180	652.5	15	877.5	28	8	31.3
112/B5	4.5	9	15	215	250	180	652.5	15	877.5	28	8	31.3
132/B5 132/B14	4.5	9	15 11	265 165	300 200	230 130	673.5	15	898.5	38	10	41.3
160/B5	5.5	10	19	300	350	250	749	18	974	42	12	45.3
180/B5	5.5	10	19	300	350	250	749	18	974	48	14	51.8

KN874.01

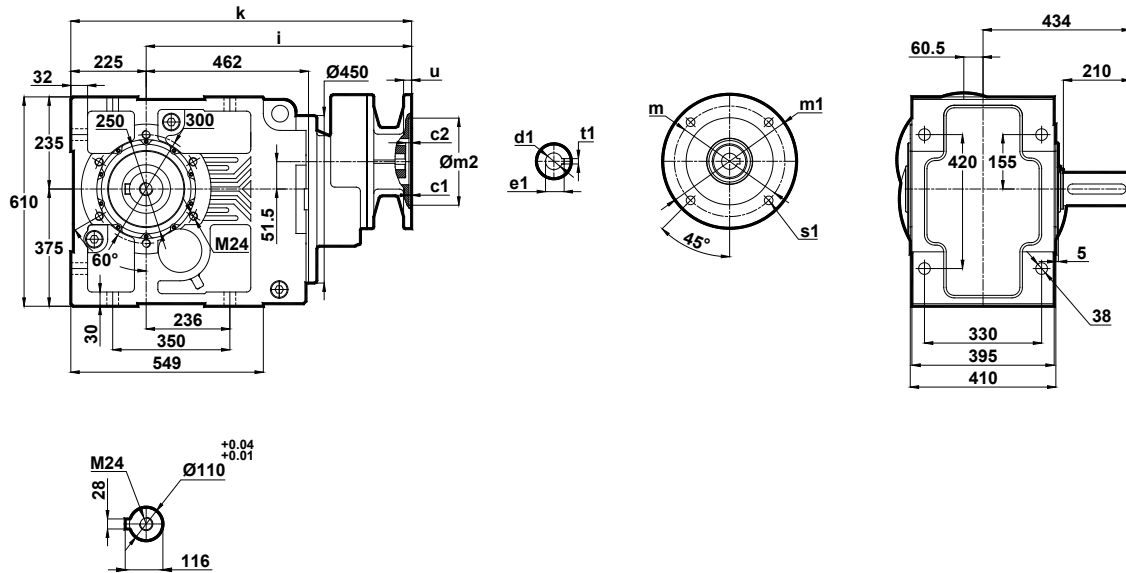

	c1	c2	s1	m	m1	m2	i	u	k	d1	t1	e1
100/B5	4.5	9	15	215	250	180	652.5	15	877.5	28	8	31.3
112/B5	4.5	9	15	215	250	180	652.5	15	877.5	28	8	31.3
132/B5 132/B14	4.5	9	15 11	265 165	300 200	230 130	673.5	15	898.5	38	10	41.3
160/B5	5.5	10	19	300	350	250	749	18	974	42	12	45.3
180/B5	5.5	10	19	300	350	250	749	18	974	48	14	51.8

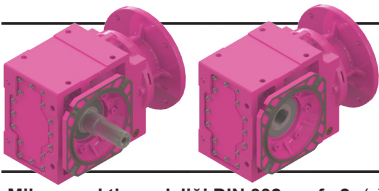

Ölçü Sayfaları

Dimension Pages

Abmessungsseiten

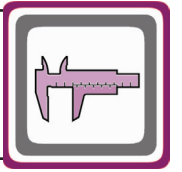

-Mil ucu çektirme deliği DIN 332 sayfa 2 / Tapped center hole to DIN 332, sheet 2 / Zentrierung mit Gewinde DIN 332, Blatt 2

KN874.02

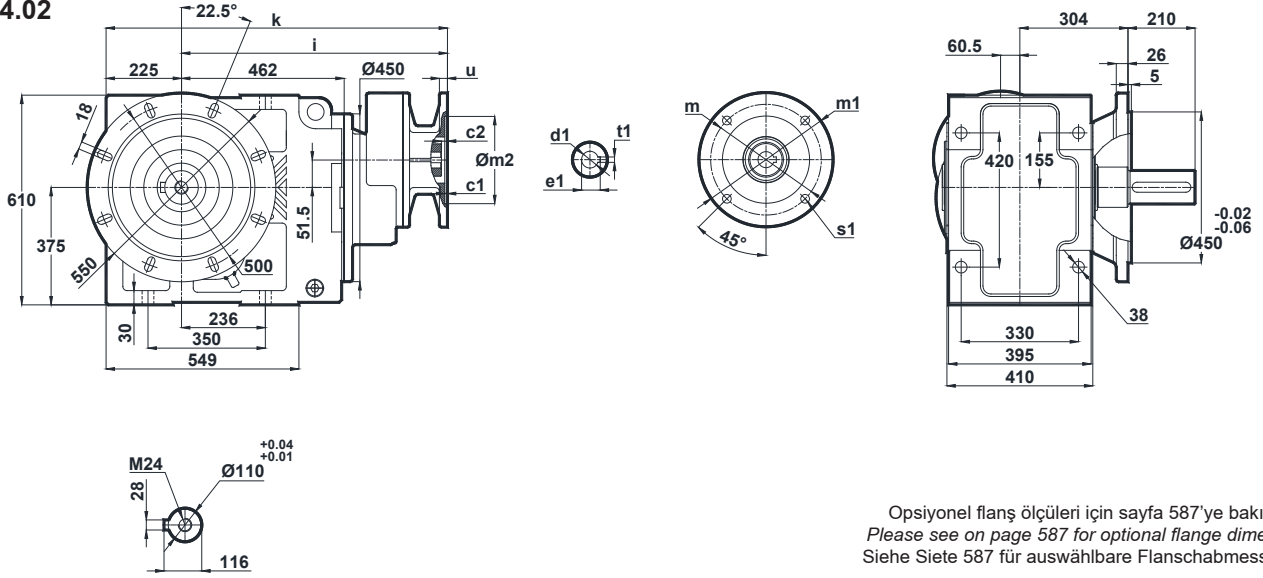

Opsiyonel flanş ölçüleri için sayfa 587'ye bakınız.
Please see on page 587 for optional flange dimensions
Siehe Siete 587 für auswählbare Flanschabmessungen

	c1	c2	s1	m	m1	m2	i	u	k	d1	t1	e1
100/B5	4.5	9	15	215	250	180	652.5	15	877.5	28	8	31.3
112/B5	4.5	9	15	215	250	180	652.5	15	877.5	28	8	31.3
132/B5 132/B14	4.5	9	15 11	265 165	300 200	230 130	673.5	15	898.5	38	10	41.3
160/B5	5.5	10	19	300	350	250	749	18	974	42	12	45.3
180/B5	5.5	10	19	300	350	250	749	18	974	48	14	51.8

KN874.03

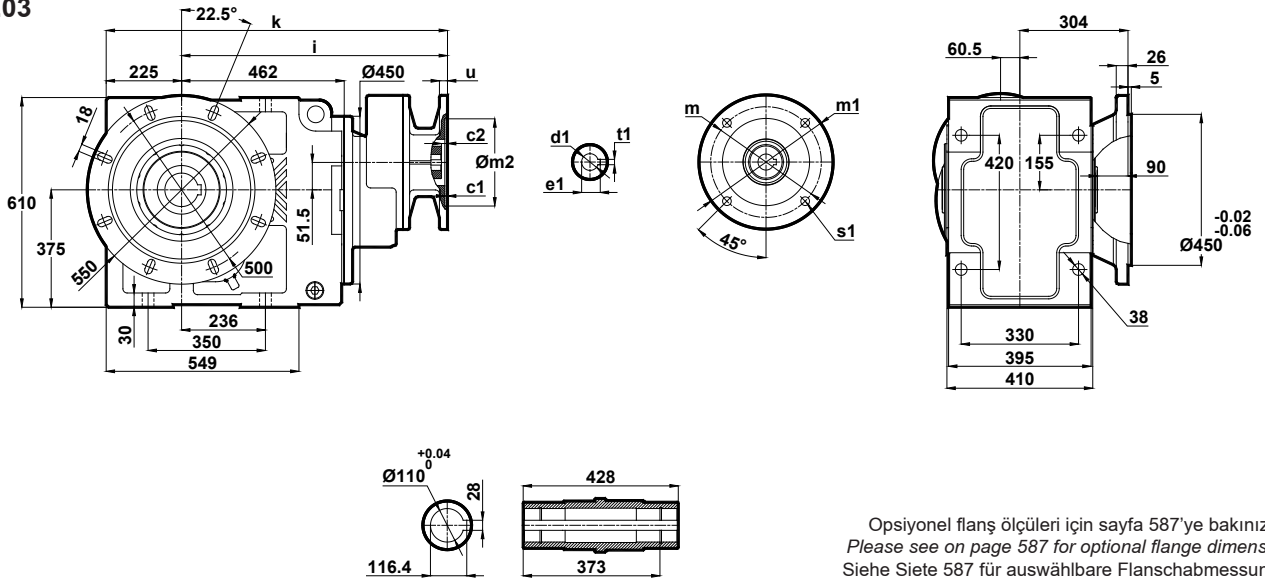

Opsiyonel flanş ölçüleri için sayfa 587'ye bakınız.
Please see on page 587 for optional flange dimensions
Siehe Siete 587 für auswählbare Flanschabmessungen

	c1	c2	s1	m	m1	m2	i	u	k	d1	t1	e1
100/B5	4.5	9	15	215	250	180	652.5	15	877.5	28	8	31.3
112/B5	4.5	9	15	215	250	180	652.5	15	877.5	28	8	31.3
132/B5 132/B14	4.5	9	15 11	265 165	300 200	230 130	673.5	15	898.5	38	10	41.3
160/B5	5.5	10	19	300	350	250	749	18	974	42	12	45.3
180/B5	5.5	10	19	300	350	250	749	18	974	48	14	51.8

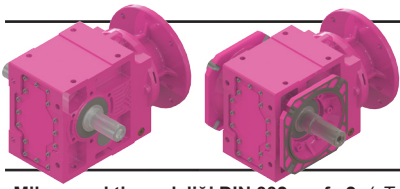

Ölçü Sayfaları

Dimension Pages

Abmessungsseiten

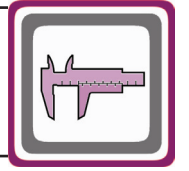

-Mil ucu çektirme deliği DIN 332 sayfa 2 / Tapped center hole to DIN 332, sheet 2 / Zentrierung mit Gewinde DIN 332, Blatt 2

KN874.04

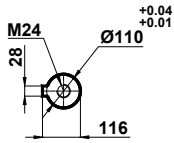
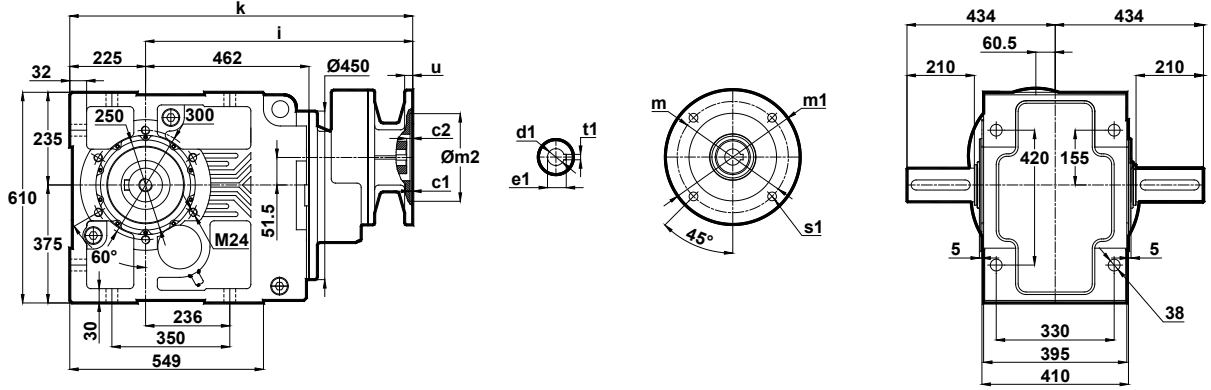

	c1	c2	s1	m	m1	m2	i	u	k	d1	t1	e1
100/B5	4.5	9	15	215	250	180	652.5	15	877.5	28	8	31.3
112/B5	4.5	9	15	215	250	180	652.5	15	877.5	28	8	31.3
132/B5 132/B14	4.5	9	15 11	265 165	300 200	230 130	673.5	15	898.5	38	10	41.3
160/B5	5.5	10	19	300	350	250	749	18	974	42	12	45.3
180/B5	5.5	10	19	300	350	250	749	18	974	48	14	51.8

KN874.05

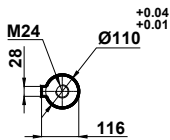
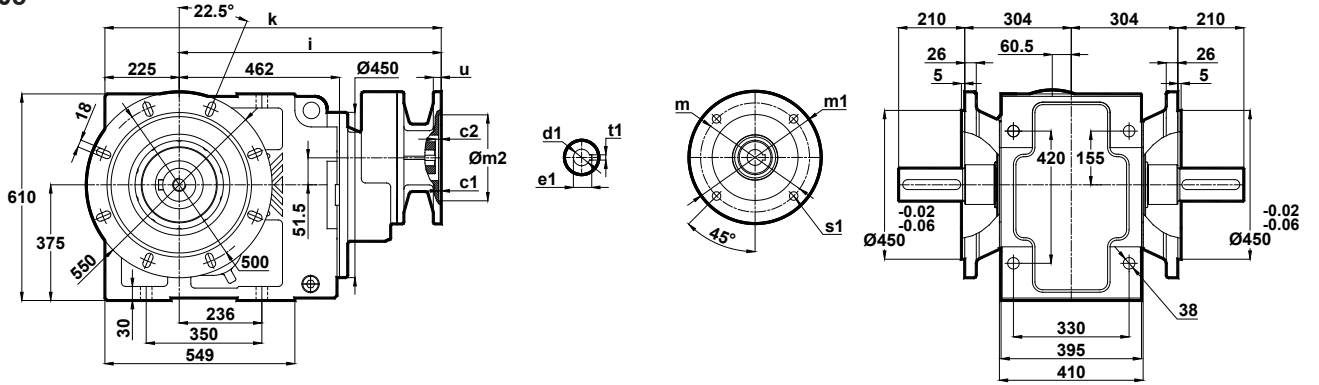

Opsiyonel flanş ölçüleri için sayfa 587'ye bakınız.
Please see on page 587 for optional flange dimensions
Siehe Seite 587 für auswählbare Flanschabmessungen

	c1	c2	s1	m	m1	m2	i	u	k	d1	t1	e1
100/B5	4.5	9	15	215	250	180	652.5	15	877.5	28	8	31.3
112/B5	4.5	9	15	215	250	180	652.5	15	877.5	28	8	31.3
132/B5 132/B14	4.5	9	15 11	265 165	300 200	230 130	673.5	15	898.5	38	10	41.3
160/B5	5.5	10	19	300	350	250	749	18	974	42	12	45.3
180/B5	5.5	10	19	300	350	250	749	18	974	48	14	51.8

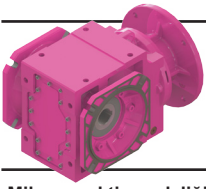

Ölçü Sayfaları Dimension Pages Abmessungenseiten

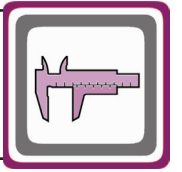

-Mil ucu çektirme deliği DIN 332 sayfa 2 / Tapped center hole to DIN 332, sheet 2 / Zentrierung mit Gewinde DIN 332, Blatt 2

KN874.08

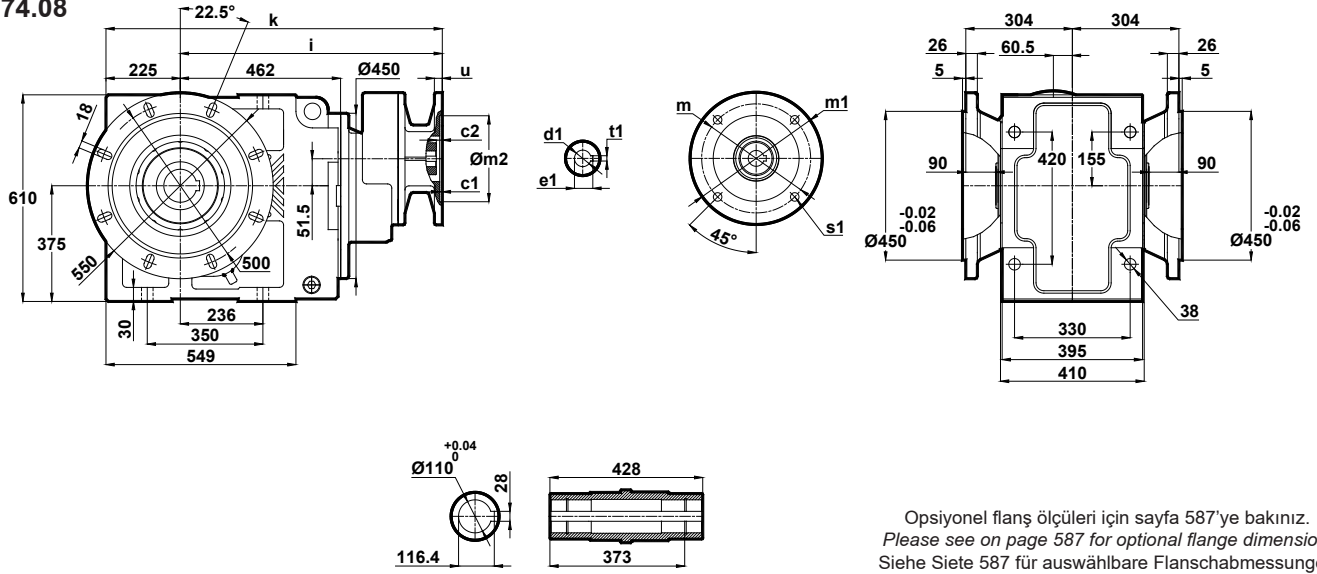

Opsiyonel flanş ölçüleri için sayfa 587'ye bakınız.
Please see on page 587 for optional flange dimensions
Siehe Seite 587 für auswählbare Flanschabmessungen

	c1	c2	s1	m	m1	m2	i	u	k	d1	t1	e1
100/B5	4.5	9	15	215	250	180	652.5	15	877.5	28	8	31.3
112/B5	4.5	9	15	215	250	180	652.5	15	877.5	28	8	31.3
132/B5 132/B14	4.5	9	15 11	265 165	300 200	230 130	673.5	15	898.5	38	10	41.3
160/B5	5.5	10	19	300	350	250	749	18	974	42	12	45.3
180/B5	5.5	10	19	300	350	250	749	18	974	48	14	51.8

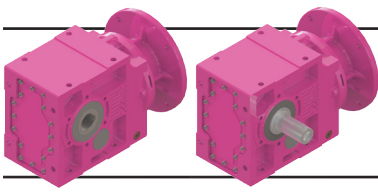

Ölçü Sayfaları

Dimension Pages

Abmessungsseiten

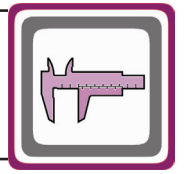

-Mil ucu çekirme deliği DIN 332 sayfa 2 / Tapped center hole to DIN 332, sheet 2 / Zentrierung mit Gewinde DIN 332, Blatt 2

KN875.00
KN876.00

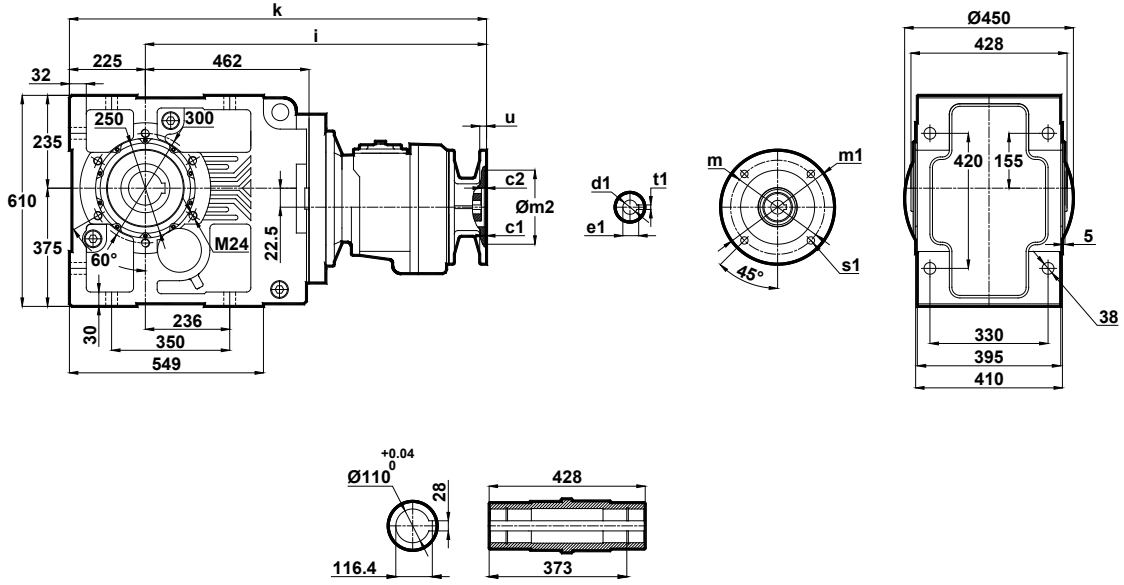

	c1	c2	s1	m	m1	m2	i	u	k	d1	t1	e1
71/B5	4	9	11	130	160	110	771.5	12	996.5	14	5	16.3
80/B5 80/B14	4	9	12 7	165 100	200 120	130 80	771.5	12	996.5	19	6 8	21.8
90/B5 90/B14	4	9	12 9	165 115	200 140	130 95	771.5	12	996.5	24	8	27.3
100/B5 100/B14	4.5 4	9	15 9	215 130	250 160	180 110	788.5	15	1013.5	28	8	31.3
112/B5 112/B14	4.5 4	9	15 9	215 130	250 160	180 110	788.5	15	1013.5	28	8	31.3

KN875.01
KN876.01

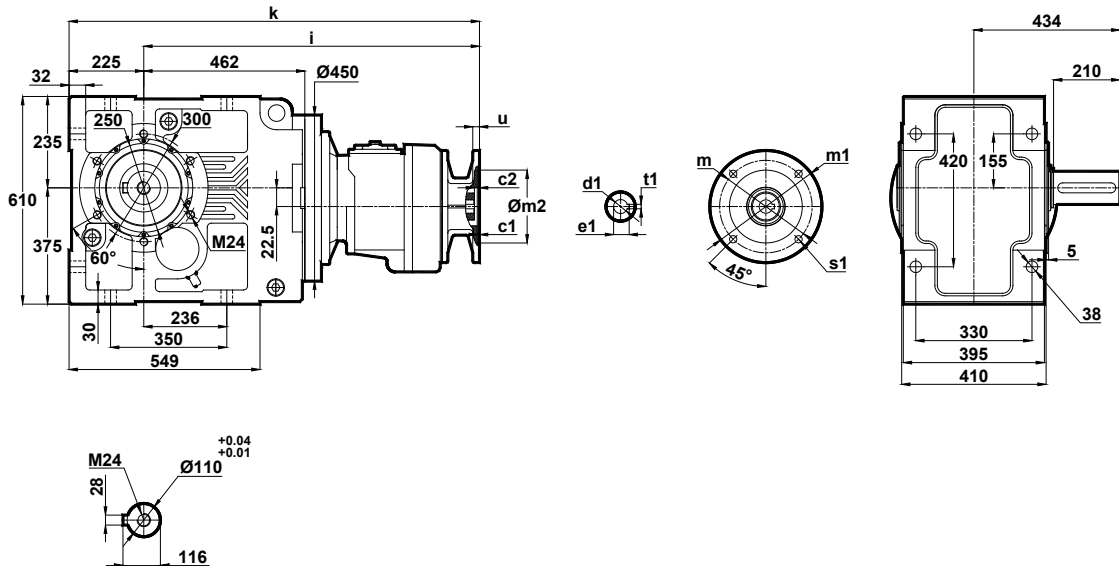

	c1	c2	s1	m	m1	m2	i	u	k	d1	t1	e1
71/B5	4	9	11	130	160	110	771.5	12	996.5	14	5	16.3
80/B5 80/B14	4	9	12 7	165 100	200 120	130 80	771.5	12	996.5	19	6 8	21.8
90/B5 90/B14	4	9	12 9	165 115	200 140	130 95	771.5	12	996.5	24	8	27.3
100/B5 100/B14	4.5 4	9	15 9	215 130	250 160	180 110	788.5	15	1013.5	28	8	31.3
112/B5 112/B14	4.5 4	9	15 9	215 130	250 160	180 110	788.5	15	1013.5	28	8	31.3

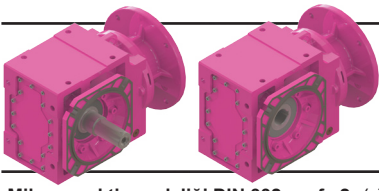

Ölçü Sayfaları

Dimension Pages

Abmessungsseiten

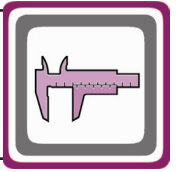

-Mil ucu çektirme deliği DIN 332 sayfa 2 / Tapped center hole to DIN 332, sheet 2 / Zentrierung mit Gewinde DIN 332, Blatt 2

KN875.02
KN876.02

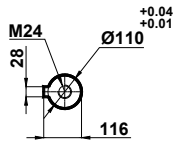
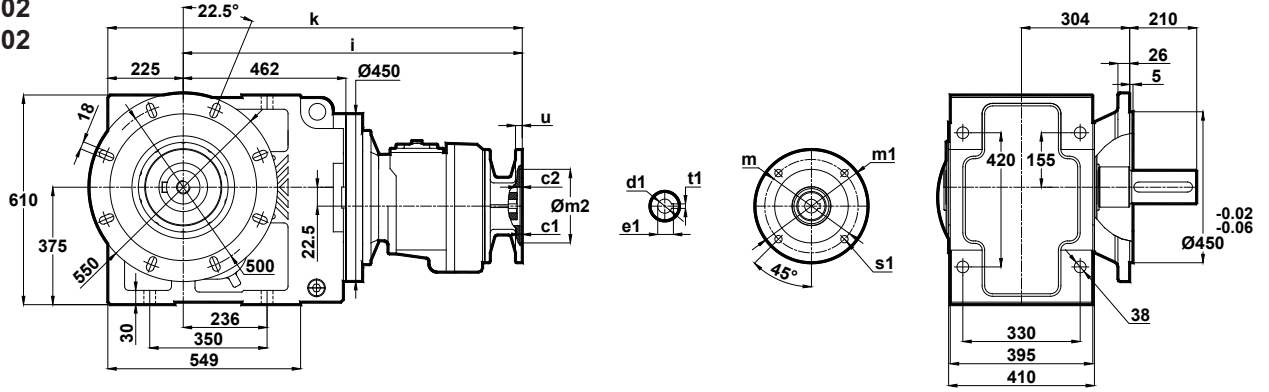

Opsiyonel flanş ölçüleri için sayfa 587'ye bakınız.
Please see on page 587 for optional flange dimensions
Siehe Seite 587 für auswählbare Flanschabmessungen

	c1	c2	s1	m	m1	m2	i	u	k	d1	t1	e1
71/B5	4	9	11	130	160	110	771.5	12	996.5	14	5	16.3
80/B5 80/B14	4	9	12 7	165 100	200 120	130 80	771.5	12	996.5	19	6 8	21.8
90/B5 90/B14	4	9	12 9	165 115	200 140	130 95	771.5	12	996.5	24	8	27.3
100/B5 100/B14	4.5 4	9	15 9	215 130	250 160	180 110	788.5	15	1013.5	28	8	31.3
112/B5 112/B14	4.5 4	9	15 9	215 130	250 160	180 110	788.5	15	1013.5	28	8	31.3

KN875.03
KN876.03

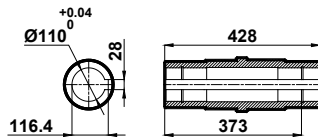
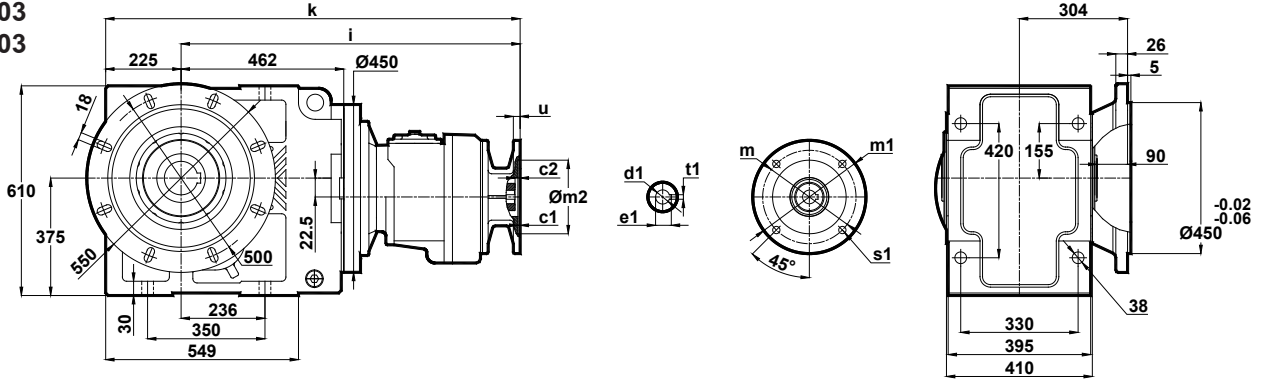

Opsiyonel flanş ölçüleri için sayfa 587'ye bakınız.
Please see on page 587 for optional flange dimensions
Siehe Seite 587 für auswählbare Flanschabmessungen

	c1	c2	s1	m	m1	m2	i	u	k	d1	t1	e1
71/B5	4	9	11	130	160	110	771.5	12	996.5	14	5	16.3
80/B5 80/B14	4	9	12 7	165 100	200 120	130 80	771.5	12	996.5	19	6 8	21.8
90/B5 90/B14	4	9	12 9	165 115	200 140	130 95	771.5	12	996.5	24	8	27.3
100/B5 100/B14	4.5 4	9	15 9	215 130	250 160	180 110	788.5	15	1013.5	28	8	31.3
112/B5 112/B14	4.5 4	9	15 9	215 130	250 160	180 110	788.5	15	1013.5	28	8	31.3

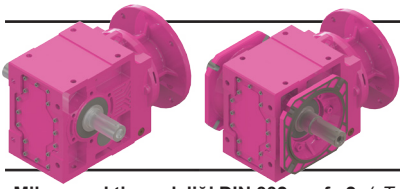

Ölçü Sayfaları

Dimension Pages

Abmessungsseiten

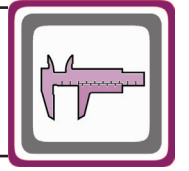

-Mil ucu çektirme deliği DIN 332 sayfa 2 / Tapped center hole to DIN 332, sheet 2 / Zentrierung mit Gewinde DIN 332, Blatt 2

KN875.04
KN876.04

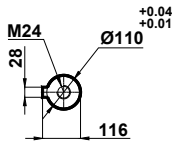
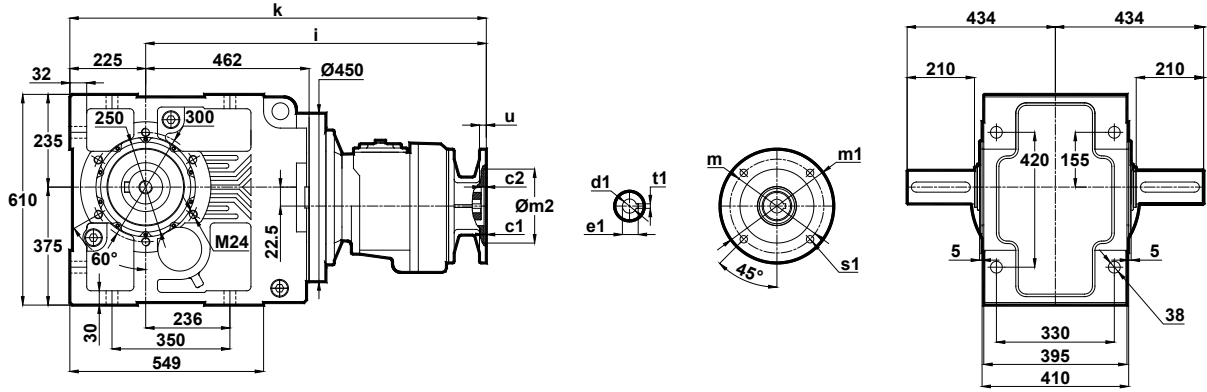

	c1	c2	s1	m	m1	m2	i	u	k	d1	t1	e1
71/B5	4	9	11	130	160	110	771.5	12	996.5	14	5	16.3
80/B5 80/B14	4	9	12 7	165 100	200 120	130 80	771.5	12	996.5	19	6 8	21.8
90/B5 90/B14	4	9	12 9	165 115	200 140	130 95	771.5	12	996.5	24	8	27.3
100/B5 100/B14	4.5 4	9	15 9	215 130	250 160	180 110	788.5	15	1013.5	28	8	31.3
112/B5 112/B14	4.5 4	9	15 9	215 130	250 160	180 110	788.5	15	1013.5	28	8	31.3

KN875.05
KN876.05

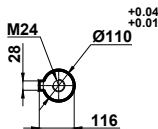
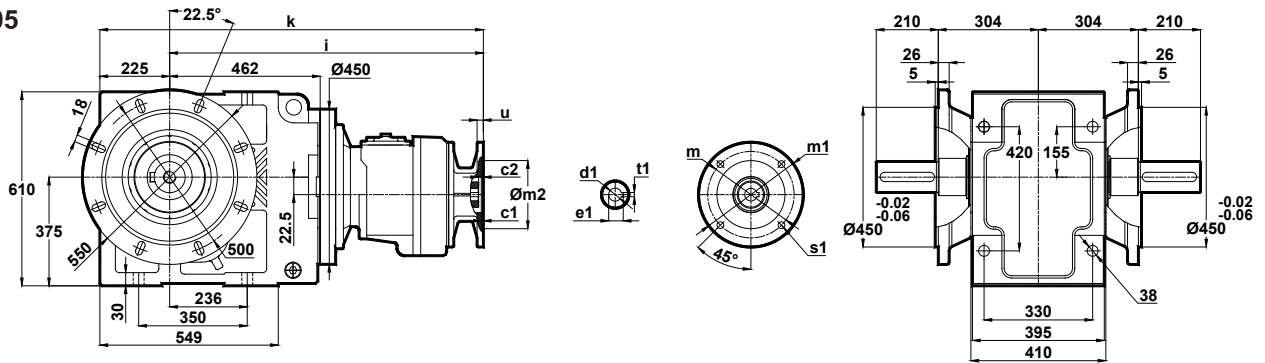

Opsiyonel flanş ölçüleri için sayfa 587'ye bakınız.
Please see on page 587 for optional flange dimensions
Siehe Seite 587 für auswählbare Flanschabmessungen

	c1	c2	s1	m	m1	m2	i	u	k	d1	t1	e1
71/B5	4	9	11	130	160	110	771.5	12	996.5	14	5	16.3
80/B5 80/B14	4	9	12 7	165 100	200 120	130 80	771.5	12	996.5	19	6 8	21.8
90/B5 90/B14	4	9	12 9	165 115	200 140	130 95	771.5	12	996.5	24	8	27.3
100/B5 100/B14	4.5 4	9	15 9	215 130	250 160	180 110	788.5	15	1013.5	28	8	31.3
112/B5 112/B14	4.5 4	9	15 9	215 130	250 160	180 110	788.5	15	1013.5	28	8	31.3

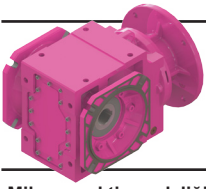

Ölçü Sayfaları Dimension Pages Abmessungenseiten

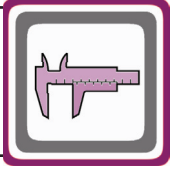

-Mil ucu çekirme deliği DIN 332 sayfa 2 / Tapped center hole to DIN 332, sheet 2 / Zentrierung mit Gewinde DIN 332, Blatt 2

KN875.08
KN876.08

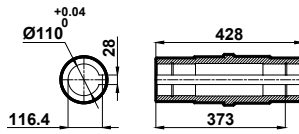
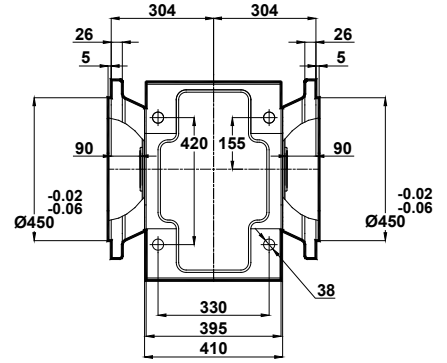
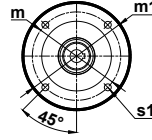
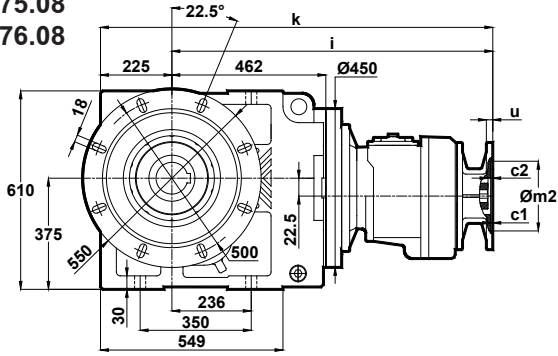

Opsiyonel flanş ölçüleri için sayfa 587'ye bakınız.
Please see on page 587 for optional flange dimensions
Siehe Seite 587 für auswählbare Flanschabmessungen

	c1	c2	s1	m	m1	m2	i	u	k	d1	t1	e1
71/B5	4	9	11	130	160	110	771.5	12	996.5	14	5	16.3
80/B5 80/B14	4	9	12 7	165 100	200 120	130 80	771.5	12	996.5	19	6 8	21.8
90/B5 90/B14	4	9	12 9	165 115	200 140	130 95	771.5	12	996.5	24	8	27.3
100/B5 100/B14	4.5 4	9	15 9	215 130	250 160	180 110	788.5	15	1013.5	28	8	31.3
112/B5 112/B14	4.5 4	9	15 9	215 130	250 160	180 110	788.5	15	1013.5	28	8	31.3

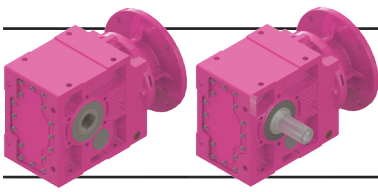

Ölçü Sayfaları

Dimension Pages

Abmessungsseiten

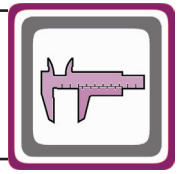

-Mil ucu çekirme deliği DIN 332 sayfa 2 / Tapped center hole to DIN 332, sheet 2 / Zentrierung mit Gewinde DIN 332, Blatt 2

KN973.00

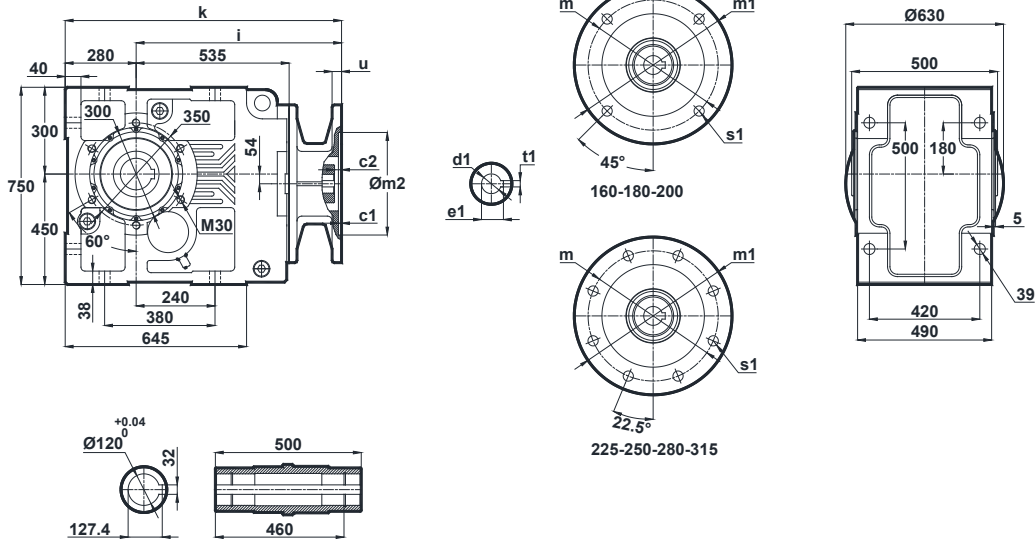

	c1	c2	s1	m	m1	m2(H7)	i	u	k	d1	t1	e1
160/B5	5.5	10	19	300	350	250	667	20	947	42	12	45.3
180/B5	5.5	10	19	300	350	250	667	20	947	48	14	51.8
200/B5	5.5	10	19	350	400	300	691	22	971	55	16	59.3
225/B5	5.5	10	19	400	450	350	733	24	1013	60	18	64.4
250/B5	5.5	10	19	500	550	450	755	24	1035	65	18	69.4
280/B5	5.5	10	19	500	550	450	755	24	1035	75	20	79.4
315/B5	6.5	15	24	660	600	550	835	24	1115	85	22	90.4

KN973.01

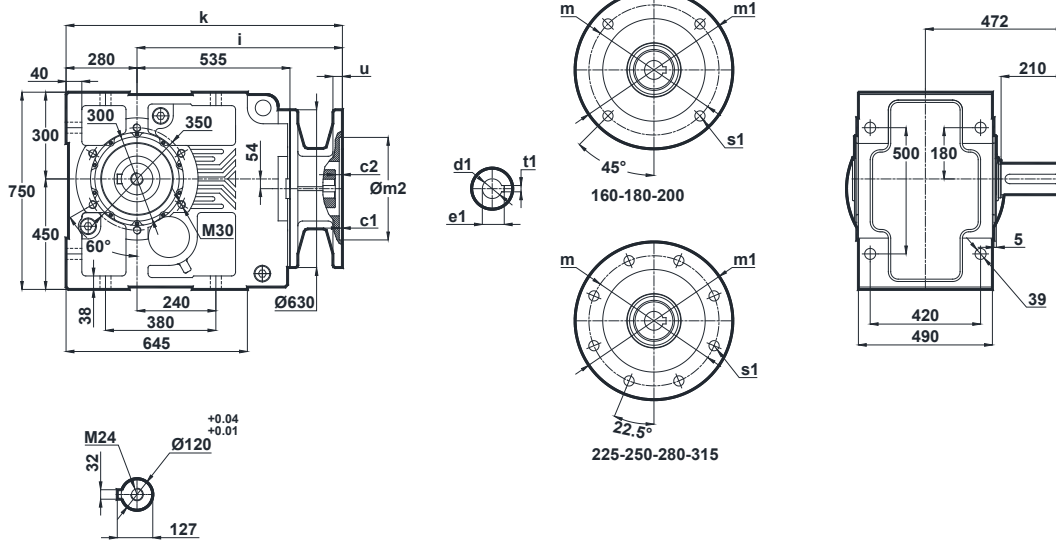

	c1	c2	s1	m	m1	m2	i	u	k	d1	t1	e1
160/B5	5.5	10	19	300	350	250	667	20	947	42	12	45.3
180/B5	5.5	10	19	300	350	250	667	20	947	48	14	51.8
200/B5	5.5	10	19	350	400	300	691	22	971	55	16	59.3
225/B5	5.5	10	19	400	450	350	733	24	1013	60	18	64.4
250/B5	5.5	10	19	500	550	450	755	24	1035	65	18	69.4
280/B5	5.5	10	19	500	550	450	755	24	1035	75	20	79.4
315/B5	6.5	15	24	660	600	550	835	24	1115	85	22	90.4

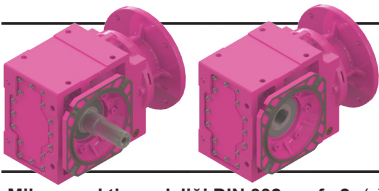

Ölçü Sayfaları

Dimension Pages

Abmessungsseiten

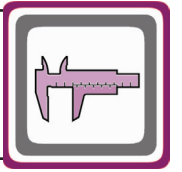

-Mil ucu çektirme deliği DIN 332 sayfa 2 / Tapped center hole to DIN 332, sheet 2 / Zentrierung mit Gewinde DIN 332, Blatt 2

KN973.02

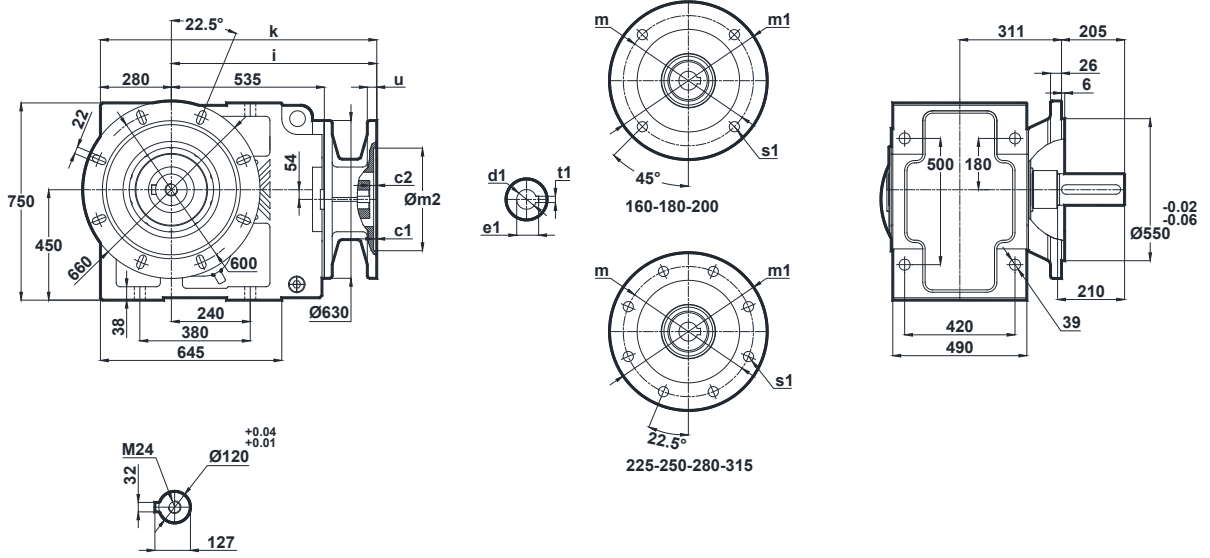

	c1	c2	s1	m	m1	m2	i	u	k	d1	t1	e1
160/B5	5.5	10	19	300	350	250	667	20	947	42	12	45.3
180/B5	5.5	10	19	300	350	250	667	20	947	48	14	51.8
200/B5	5.5	10	19	350	400	300	691	22	971	55	16	59.3
225/B5	5.5	10	19	400	450	350	733	24	1013	60	18	64.4
250/B5	5.5	10	19	500	550	450	755	24	1035	65	18	69.4
280/B5	5.5	10	19	500	550	450	755	24	1035	75	20	79.4
315/B5	6.5	15	24	660	600	550	835	24	1115	85	22	90.4

KN973.03

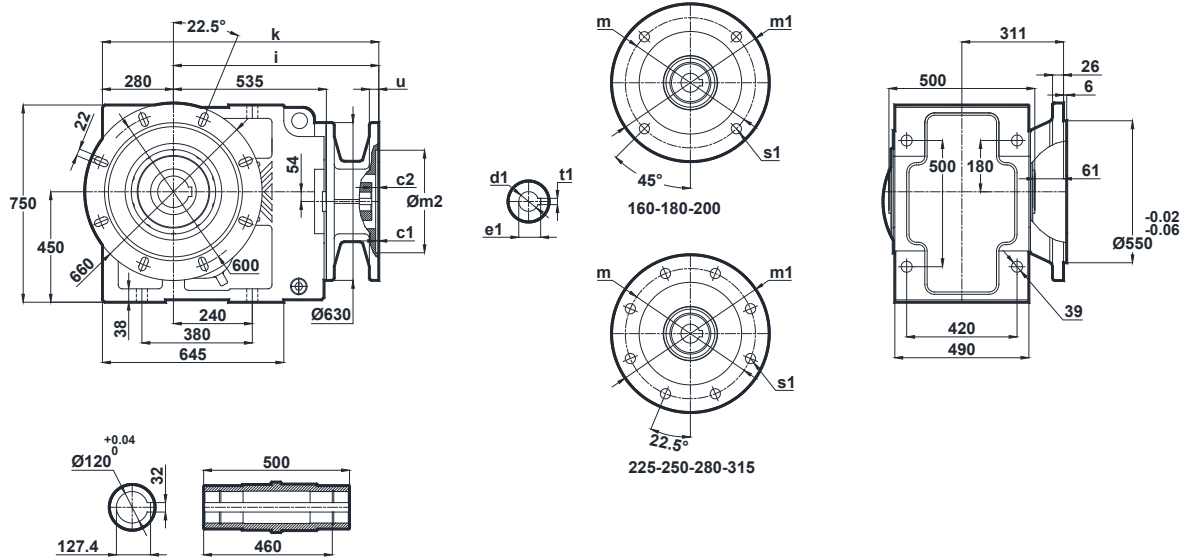

	c1	c2	s1	m	m1	m2	i	u	k	d1	t1	e1
160/B5	5.5	10	19	300	350	250	667	20	947	42	12	45.3
180/B5	5.5	10	19	300	350	250	667	20	947	48	14	51.8
200/B5	5.5	10	19	350	400	300	691	22	971	55	16	59.3
225/B5	5.5	10	19	400	450	350	733	24	1013	60	18	64.4
250/B5	5.5	10	19	500	550	450	755	24	1035	65	18	69.4
280/B5	5.5	10	19	500	550	450	755	24	1035	75	20	79.4
315/B5	6.5	15	24	660	600	550	835	24	1115	85	22	90.4

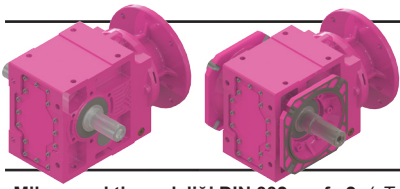

Ölçü Sayfaları

Dimension Pages

Abmessungsseiten

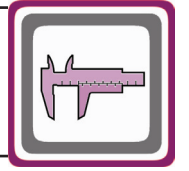

-Mil ucu çekirme deliği DIN 332 sayfa 2 / Tapped center hole to DIN 332, sheet 2 / Zentrierung mit Gewinde DIN 332, Blatt 2

KN973.04

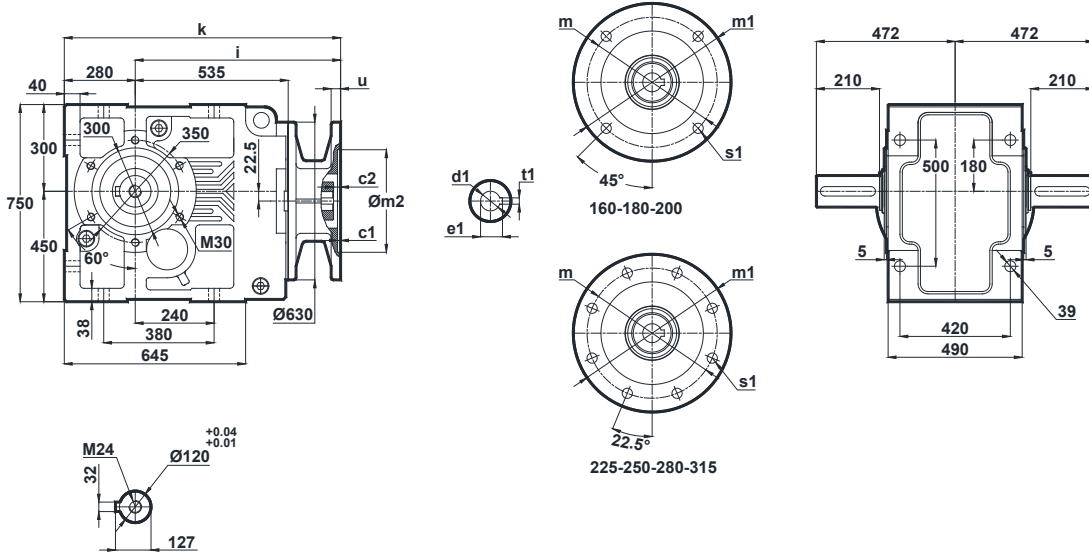

	c1	c2	s1	m	m1	m2	i	u	k	d1	t1	e1
160/B5	5.5	10	19	300	350	250	667	20	947	42	12	45.3
180/B5	5.5	10	19	300	350	250	667	20	947	48	14	51.8
200/B5	5.5	10	19	350	400	300	691	22	971	55	16	59.3
225/B5	5.5	10	19	400	450	350	733	24	1013	60	18	64.4
250/B5	5.5	10	19	500	550	450	755	24	1035	65	18	69.4
280/B5	5.5	10	19	500	550	450	755	24	1035	75	20	79.4
315/B5	6.5	15	24	660	600	550	835	24	1115	85	22	90.4

KN973.05

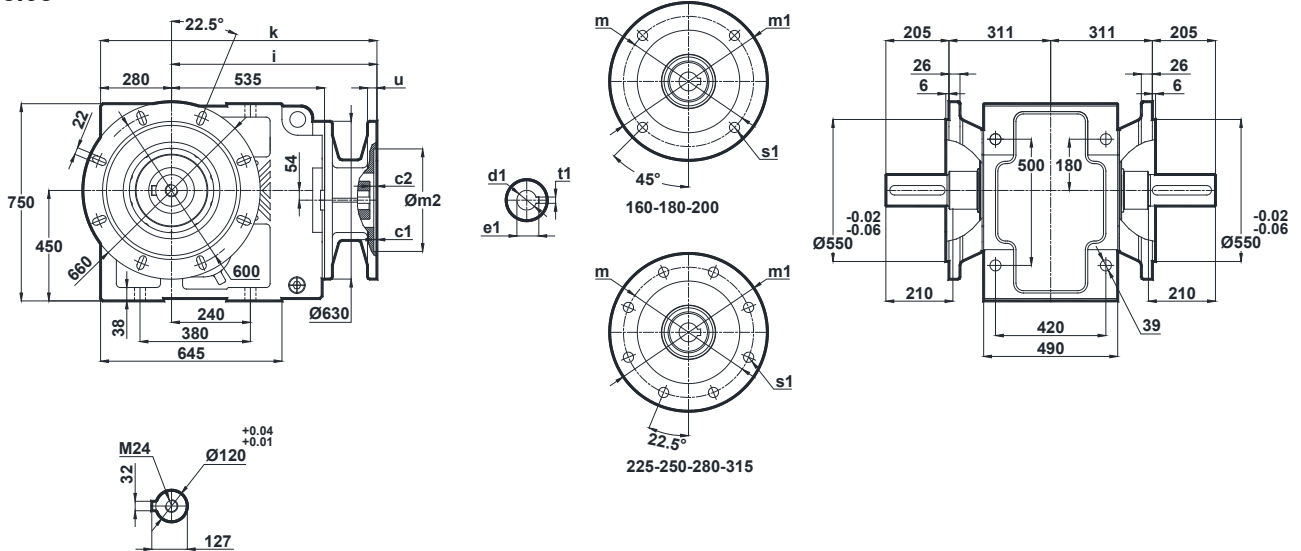

	c1	c2	s1	m	m1	m2	i	u	k	d1	t1	e1
160/B5	5.5	10	19	300	350	250	667	20	947	42	12	45.3
180/B5	5.5	10	19	300	350	250	667	20	947	48	14	51.8
200/B5	5.5	10	19	350	400	300	691	22	971	55	16	59.3
225/B5	5.5	10	19	400	450	350	733	24	1013	60	18	64.4
250/B5	5.5	10	19	500	550	450	755	24	1035	65	18	69.4
280/B5	5.5	10	19	500	550	450	755	24	1035	75	20	79.4
315/B5	6.5	15	24	660	600	550	835	24	1115	85	22	90.4

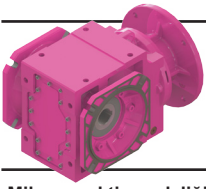

Ölçü Sayfaları Dimension Pages Abmessungsseiten

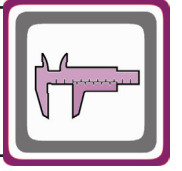

-Mil ucu çekirme deliği DIN 332 sayfa 2 / Tapped center hole to DIN 332, sheet 2 / Zentrierung mit Gewinde DIN 332, Blatt 2

KN973.08

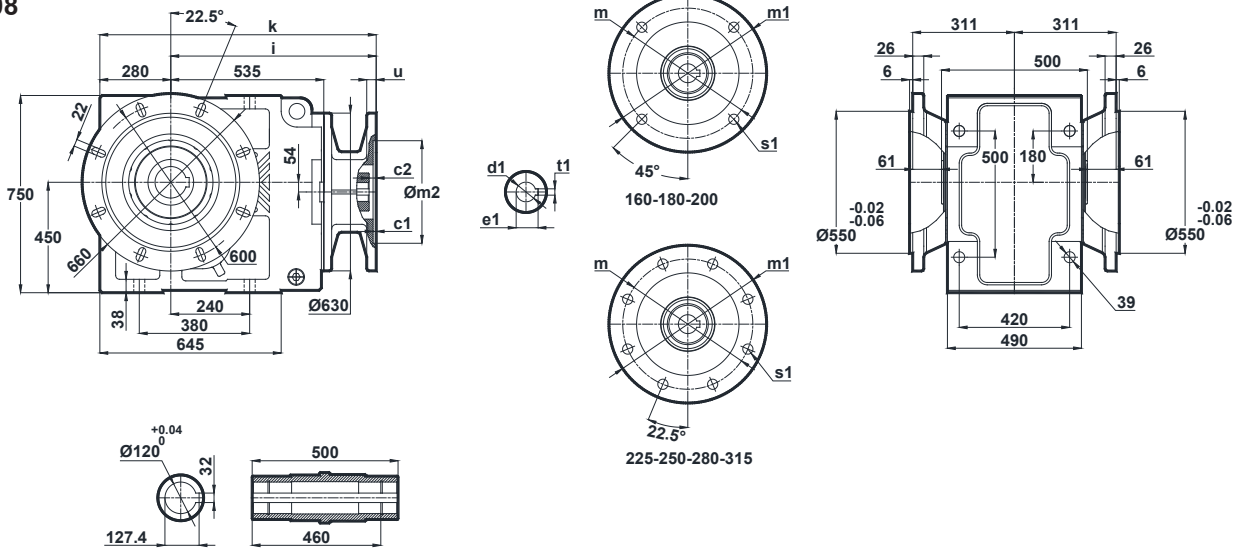

	c1	c2	s1	m	m1	m2	i	u	k	d1	t1	e1
160/B5	5.5	10	19	300	350	250	667	20	947	42	12	45.3
180/B5	5.5	10	19	300	350	250	667	20	947	48	14	51.8
200/B5	5.5	10	19	350	400	300	691	22	971	55	16	59.3
225/B5	5.5	10	19	400	450	350	733	24	1013	60	18	64.4
250/B5	5.5	10	19	500	550	450	755	24	1035	65	18	69.4
280/B5	5.5	10	19	500	550	450	755	24	1035	75	20	79.4
315/B5	6.5	15	24	660	600	550	835	24	1115	85	22	90.4

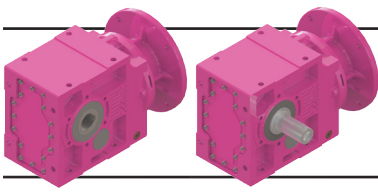

Ölçü Sayfaları

Dimension Pages

Abmessungsseiten

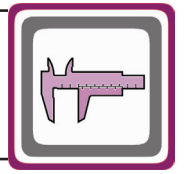

-Mil ucu çekirme deliği DIN 332 sayfa 2 / Tapped center hole to DIN 332, sheet 2 / Zentrierung mit Gewinde DIN 332, Blatt 2

KN974.00

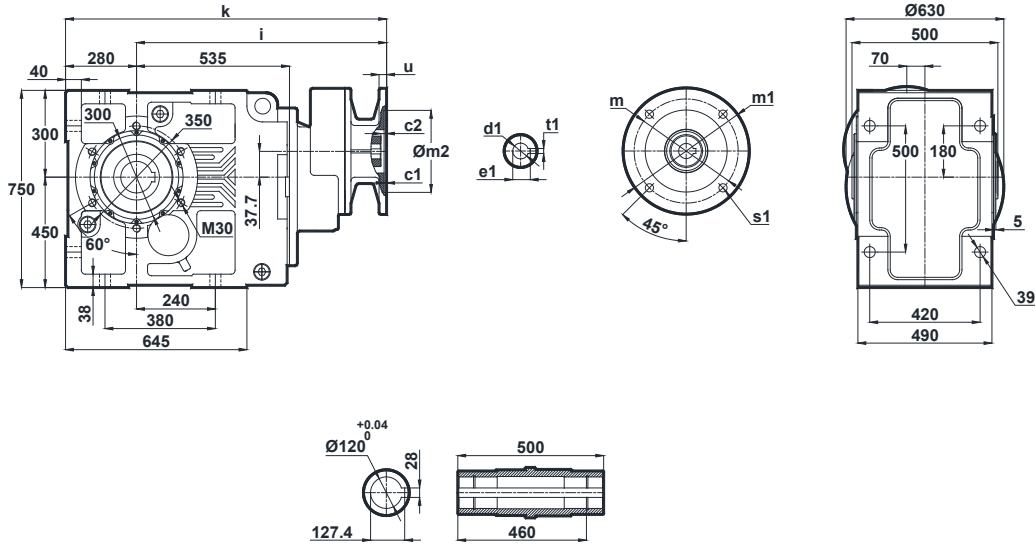

	c1	c2	s1	m	m1	m2(H7)	i	u	k	d1	t1	e1
100/B5	5	15	15	215	250	180	755.5	15	1035.5	28	8	31.3
112/B5	5	15	15	215	250	180	755.5	15	1035.5	28	8	31.3
132/B5 132/B14	4.5	9	15	265 165	300 200	230 130	770.5	15	1050.5	38	10	41.3
160/B5	5.5	10	19	300	350	250	845.5	20	1125.5	42	12	45.3
180/B5	5.5	10	19	300	350	250	845.5	20	1125.5	48	14	51.8

KN974.01

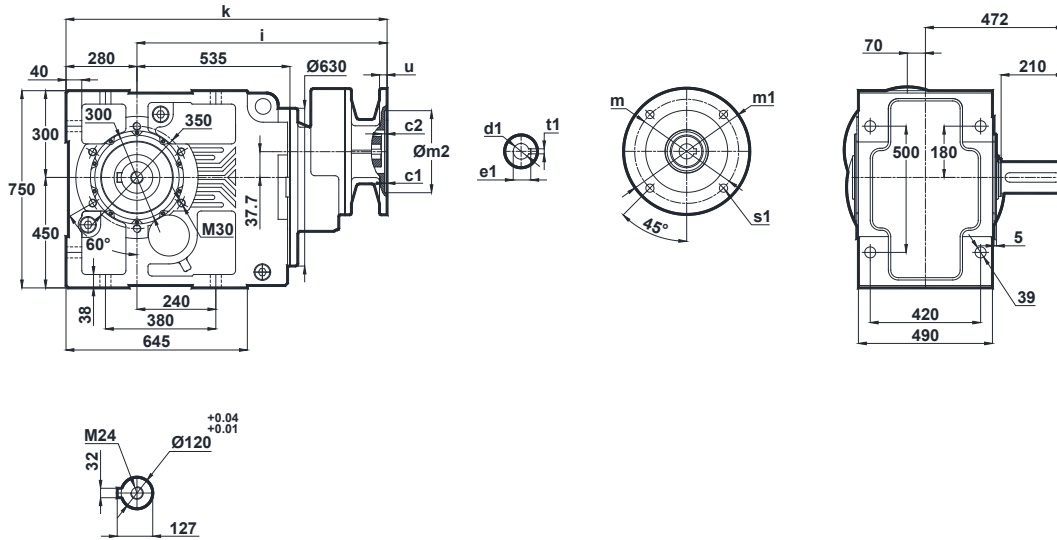

	c1	c2	s1	m	m1	m2	i	u	k	d1	t1	e1
100/B5	5	15	15	215	250	180	755.5	15	1035.5	28	8	31.3
112/B5	5	15	15	215	250	180	755.5	15	1035.5	28	8	31.3
132/B5 132/B14	4.5	9	15	265 165	300 200	230 130	770.5	15	1050.5	38	10	41.3
160/B5	5.5	10	19	300	350	250	845.5	20	1125.5	42	12	45.3
180/B5	5.5	10	19	300	350	250	845.5	20	1125.5	48	14	51.8

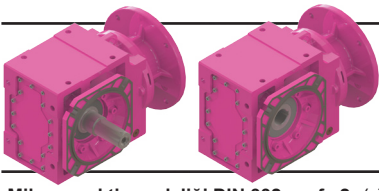

Ölçü Sayfaları

Dimension Pages

Abmessungsseiten

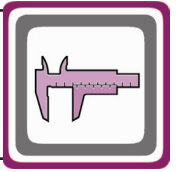

-Mil ucu çektirme deliği DIN 332 sayfa 2 / Tapped center hole to DIN 332, sheet 2 / Zentrierung mit Gewinde DIN 332, Blatt 2

KN974.02

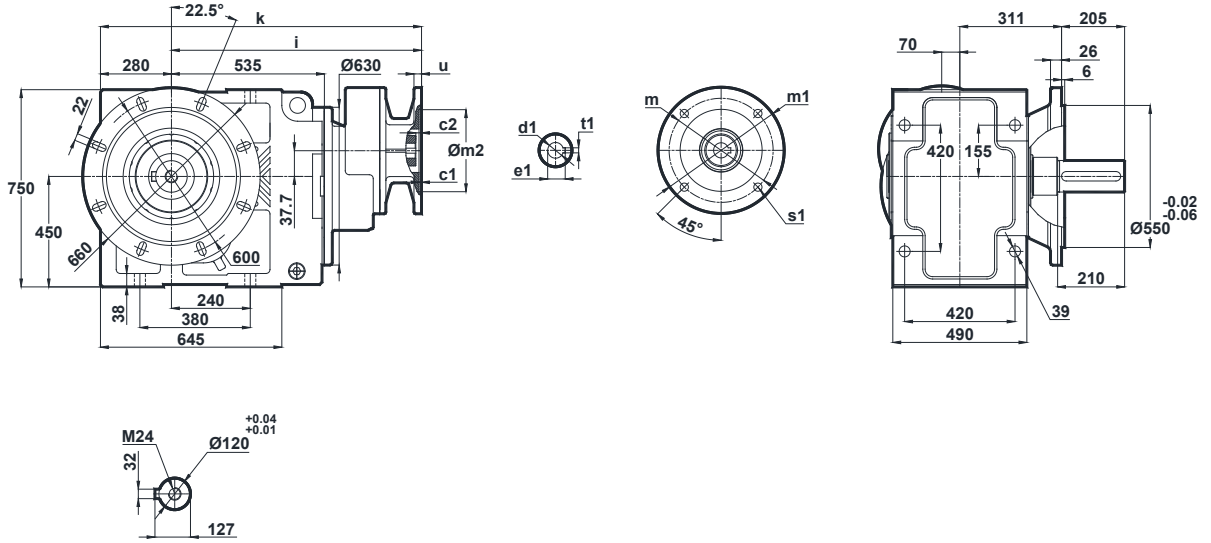

	c1	c2	s1	m	m1	m2	i	u	k	d1	t1	e1
100/B5	5	15	15	215	250	180	755.5	15	1035.5	28	8	31.3
112/B5	5	15	15	215	250	180	755.5	15	1035.5	28	8	31.3
132/B5 132/B14	4.5	9	15	265 165	300 200	230 130	770.5	15	1050.5	38	10	41.3
160/B5	5.5	10	19	300	350	250	845.5	20	1125.5	42	12	45.3
180/B5	5.5	10	19	300	350	250	845.5	20	1125.5	48	14	51.8

KN974.03

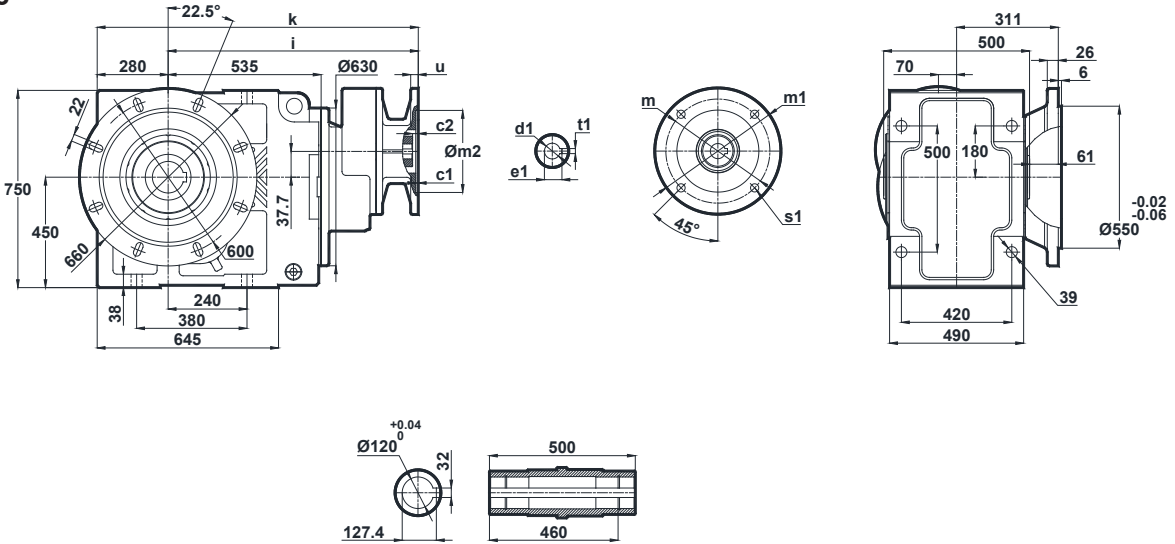

	c1	c2	s1	m	m1	m2	i	u	k	d1	t1	e1
100/B5	5	15	15	215	250	180	755.5	15	1035.5	28	8	31.3
112/B5	5	15	15	215	250	180	755.5	15	1035.5	28	8	31.3
132/B5 132/B14	4.5	9	15	265 165	300 200	230 130	770.5	15	1050.5	38	10	41.3
160/B5	5.5	10	19	300	350	250	845.5	20	1125.5	42	12	45.3
180/B5	5.5	10	19	300	350	250	845.5	20	1125.5	48	14	51.8

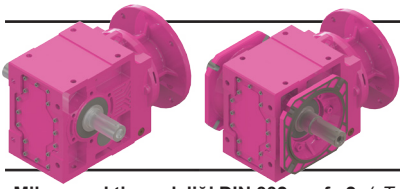

Ölçü Sayfaları

Dimension Pages

Abmessungsseiten

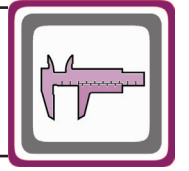

-Mil ucu çekirme deliği DIN 332 sayfa 2 / Tapped center hole to DIN 332, sheet 2 / Zentrierung mit Gewinde DIN 332, Blatt 2

KN974.04

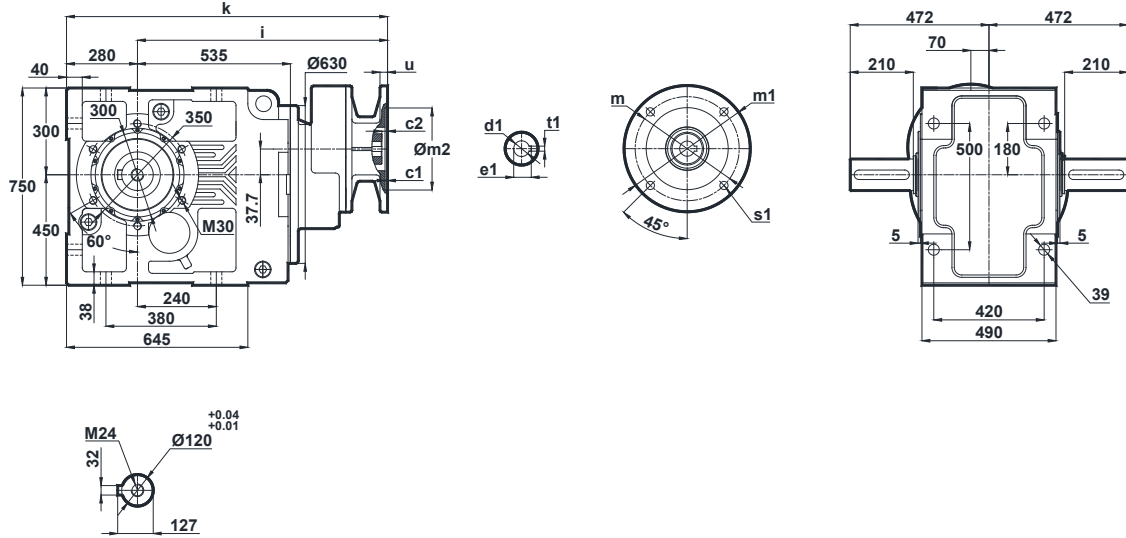

	c1	c2	s1	m	m1	m2	i	u	k	d1	t1	e1
100/B5	5	15	15	215	250	180	755.5	15	1035.5	28	8	31.3
112/B5	5	15	15	215	250	180	755.5	15	1035.5	28	8	31.3
132/B5 132/B14	4.5	9	15	265 165	300 200	230 130	770.5	15	1050.5	38	10	41.3
160/B5	5.5	10	19	300	350	250	845.5	20	1125.5	42	12	45.3
180/B5	5.5	10	19	300	350	250	845.5	20	1125.5	48	14	51.8

KN974.05

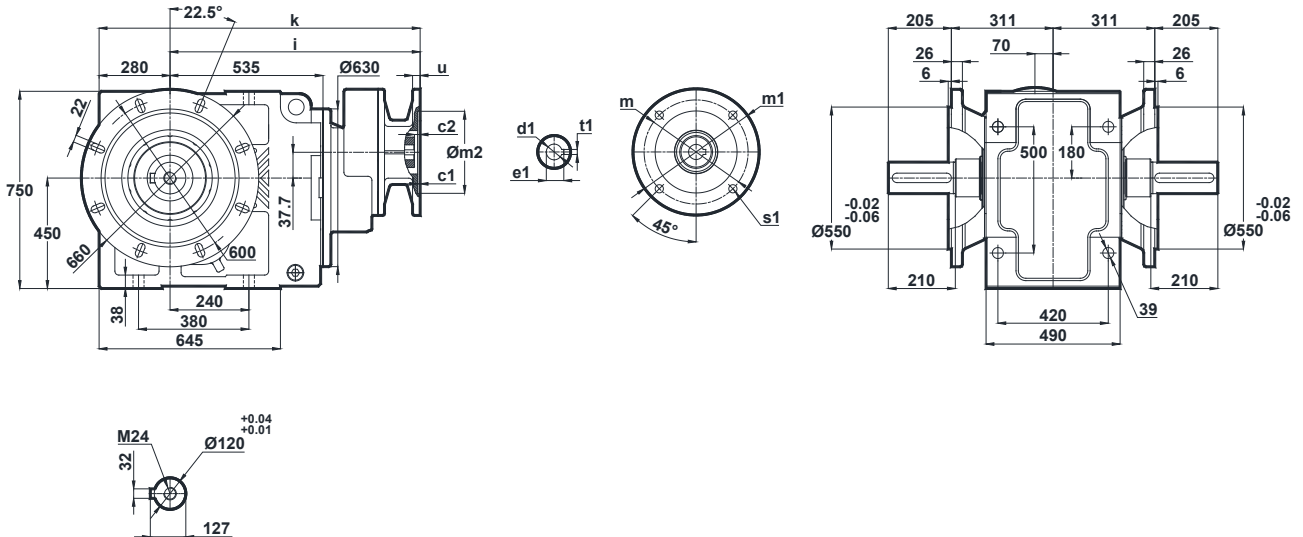

	c1	c2	s1	m	m1	m2	i	u	k	d1	t1	e1
100/B5	5	15	15	215	250	180	755.5	15	1035.5	28	8	31.3
112/B5	5	15	15	215	250	180	755.5	15	1035.5	28	8	31.3
132/B5 132/B14	4.5	9	15	265 165	300 200	230 130	770.5	15	1050.5	38	10	41.3
160/B5	5.5	10	19	300	350	250	845.5	20	1125.5	42	12	45.3
180/B5	5.5	10	19	300	350	250	845.5	20	1125.5	48	14	51.8

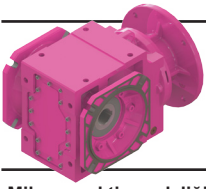

Ölçü Sayfaları Dimension Pages Abmessungenseiten

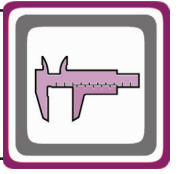

-Mil ucu çekirme deliği DIN 332 sayfa 2 / Tapped center hole to DIN 332, sheet 2 / Zentrierung mit Gewinde DIN 332, Blatt 2

KN974.08

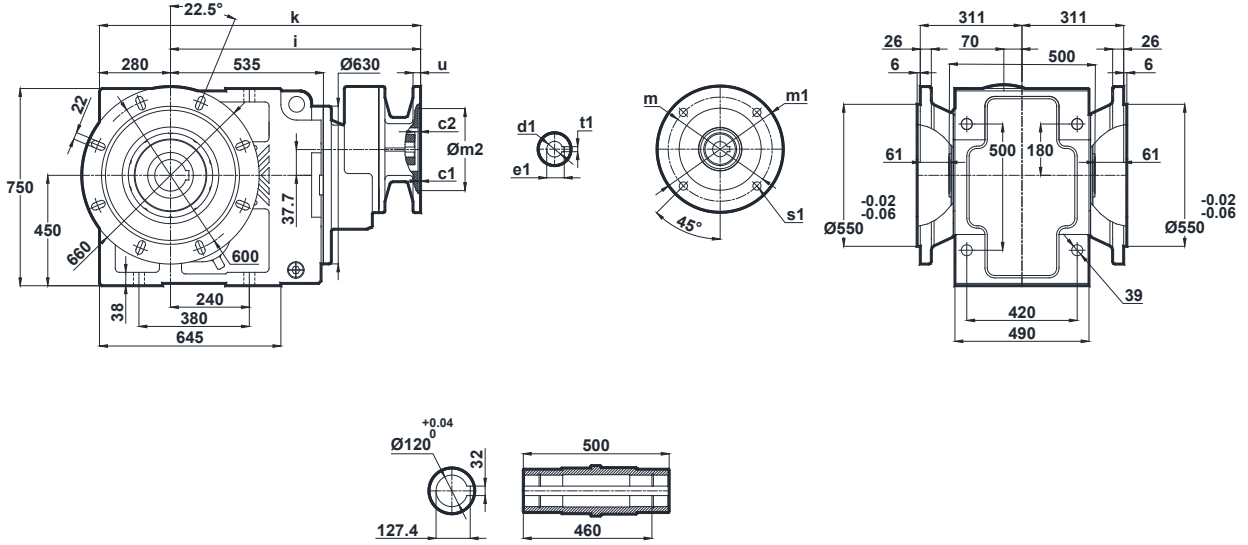

	c1	c2	s1	m	m1	m2	i	u	k	d1	t1	e1
100/B5	5	15	15	215	250	180	755.5	15	1035.5	28	8	31.3
112/B5	5	15	15	215	250	180	755.5	15	1035.5	28	8	31.3
132/B5 132/B14	4.5	9	15	265 165	300 200	230 130	770.5	15	1050.5	38	10	41.3
160/B5	5.5	10	19	300	350	250	845.5	20	1125.5	42	12	45.3
180/B5	5.5	10	19	300	350	250	845.5	20	1125.5	48	14	51.8

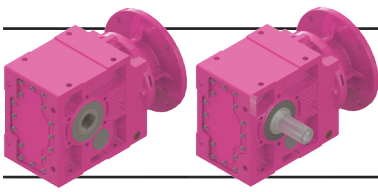

Ölçü Sayfaları

Dimension Pages

Abmessungsseiten

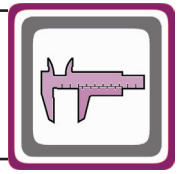

-Mil ucu çektirme deliği DIN 332 sayfa 2 / Tapped center hole to DIN 332, sheet 2 / Zentrierung mit Gewinde DIN 332, Blatt 2

KN975.00
KN976.00

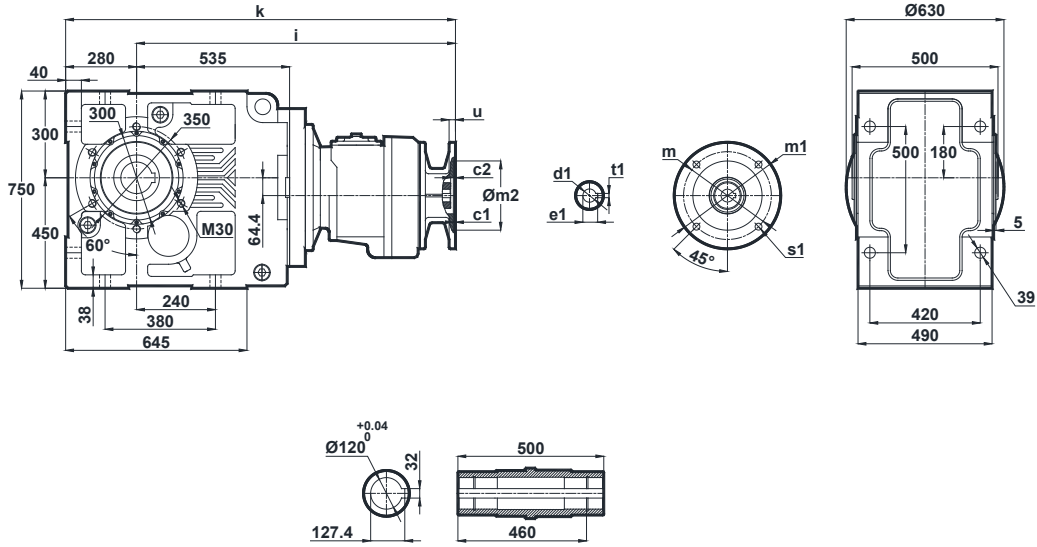

	c1	c2	s1	m	m1	m2(H7)	i	u	k	d1	t1	e1
80/B5 80/B14	4	4	12	165	200	130	891.5	12	1171.5	19	6	21.8
90/B5 90/B14	4	5	12	165	200	130	891.5	12	1171.5	24	8	27.3
100/B5 100/B14	5	9	15	215	250	180	910	15	1190	28	8	31.3
112/B5 112/B14	4.5	9	9	215	250	180	910	15	1190	28	8	31.3
132/B5 132/B14	4.5	9	15	265	300	230	928.5	15	1208.5	38	10	41.3

KN975.01
KN976.01

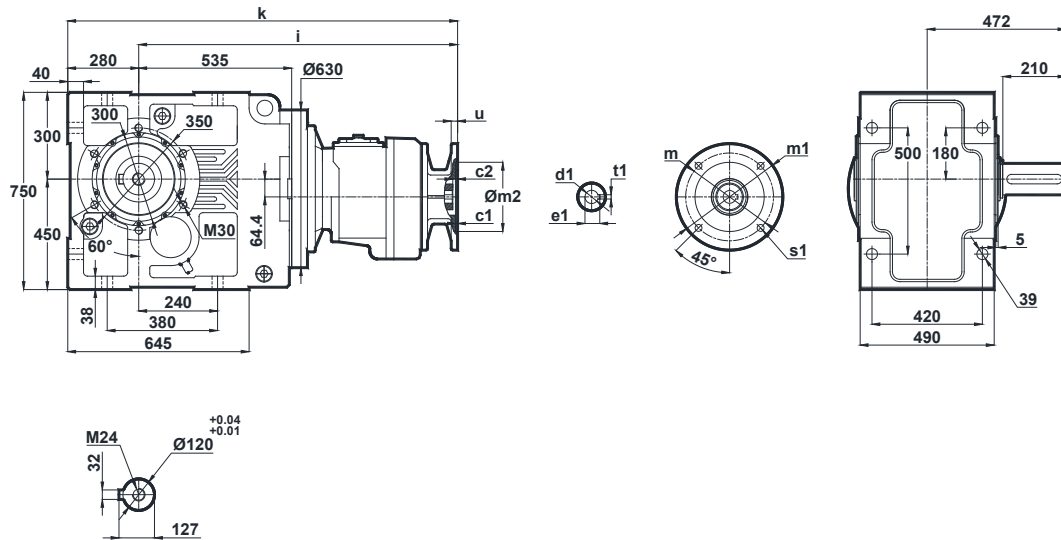

	c1	c2	s1	m	m1	m2	i	u	k	d1	t1	e1
80/B5 80/B14	4	4	12	165	200	130	891.5	12	1171.5	19	6	21.8
90/B5 90/B14	4	5	12	165	200	130	891.5	12	1171.5	24	8	27.3
100/B5 100/B14	5	9	15	215	250	180	910	15	1190	28	8	31.3
112/B5 112/B14	4.5	9	9	215	250	180	910	15	1190	28	8	31.3
132/B5 132/B14	4.5	9	15	265	300	230	928.5	15	1208.5	38	10	41.3

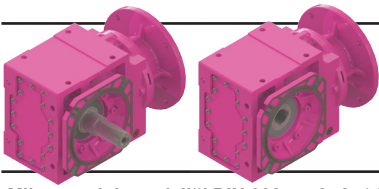

Ölçü Sayfaları

Dimension Pages

Abmessungsseiten

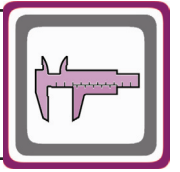

-Mil ucu çektirme deliği DIN 332 sayfa 2 / Tapped center hole to DIN 332, sheet 2 / Zentrierung mit Gewinde DIN 332, Blatt 2

KN975.02
KN976.02

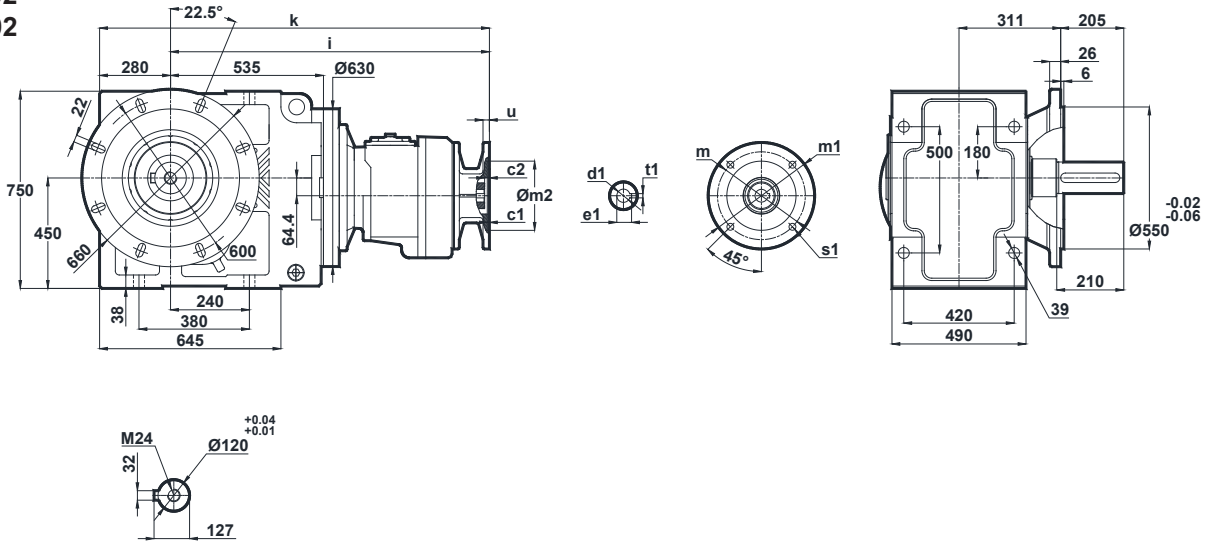

	c1	c2	s1	m	m1	m2	i	u	k	d1	t1	e1
80/B5 80/B14	4	4	12	165	200	130	891.5	12	1171.5	19	6	21.8
90/B5 90/B14	4	5	12 9	165 115	200 140	130 95	891.5	12	1171.5	24	8	27.3
100/B5 100/B14	5 4	9	15 9	215 130	250 160	180 110	910	15	1190	28	8	31.3
112/B5 112/B14	4.5	9	9	215 130	250 160	180 110	910	15	1190	28	8	31.3
132/B5 132/B14	4.5	9	15	265 165	300 200	230 130	928.5	15	1208.5	38	10	41.3

KN975.03
KN976.03

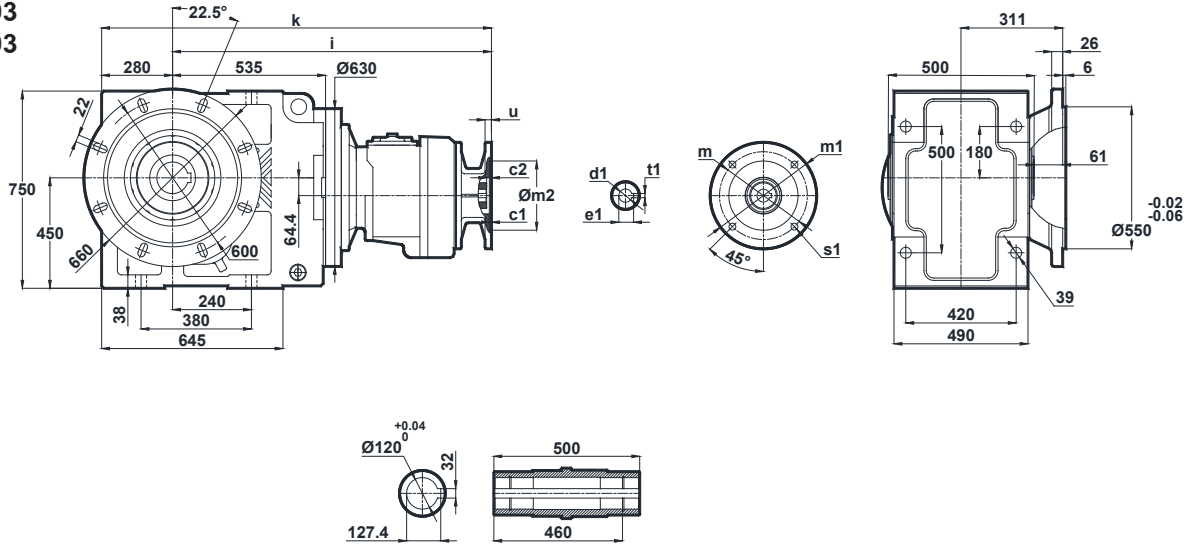

	c1	c2	s1	m	m1	m2	i	u	k	d1	t1	e1
80/B5 80/B14	4	4	12	165	200	130	891.5	12	1171.5	19	6	21.8
90/B5 90/B14	4	5	12 9	165 115	200 140	130 95	891.5	12	1171.5	24	8	27.3
100/B5 100/B14	5 4	9	15 9	215 130	250 160	180 110	910	15	1190	28	8	31.3
112/B5 112/B14	4.5	9	9	215 130	250 160	180 110	910	15	1190	28	8	31.3
132/B5 132/B14	4.5	9	15	265 165	300 200	230 130	928.5	15	1208.5	38	10	41.3

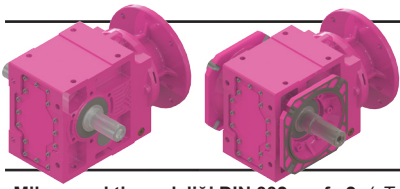

Ölçü Sayfaları

Dimension Pages

Abmessungsseiten

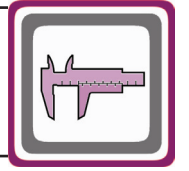

-Mil ucu çekirme deliği DIN 332 sayfa 2 / Tapped center hole to DIN 332, sheet 2 / Zentrierung mit Gewinde DIN 332, Blatt 2

KN975.04
KN976.04

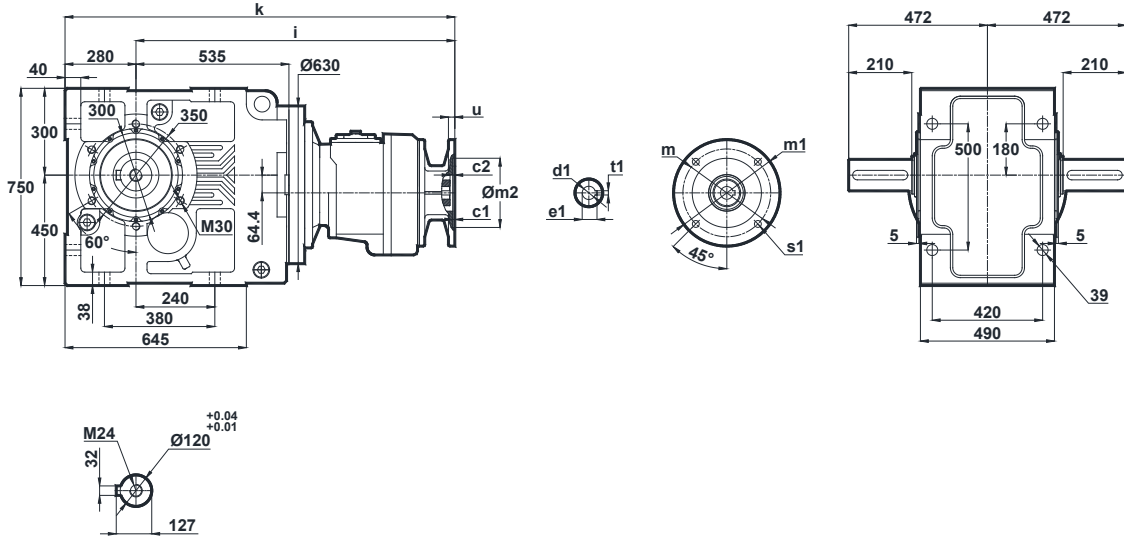

	c1	c2	s1	m	m1	m2	i	u	k	d1	t1	e1
80/B5 80/B14	4	4	12	165	200	130	891.5	12	1171.5	19	6	21.8
90/B5 90/B14	4	5	12	165	200	130	891.5	12	1171.5	24	8	27.3
100/B5 100/B14	5	9	15	215	250	180	910	15	1190	28	8	31.3
112/B5 112/B14	4.5	9	9	215	250	180	910	15	1190	28	8	31.3
132/B5 132/B14	4.5	9	15	265	300	230	928.5	15	1208.5	38	10	41.3

KN975.05
KN976.05

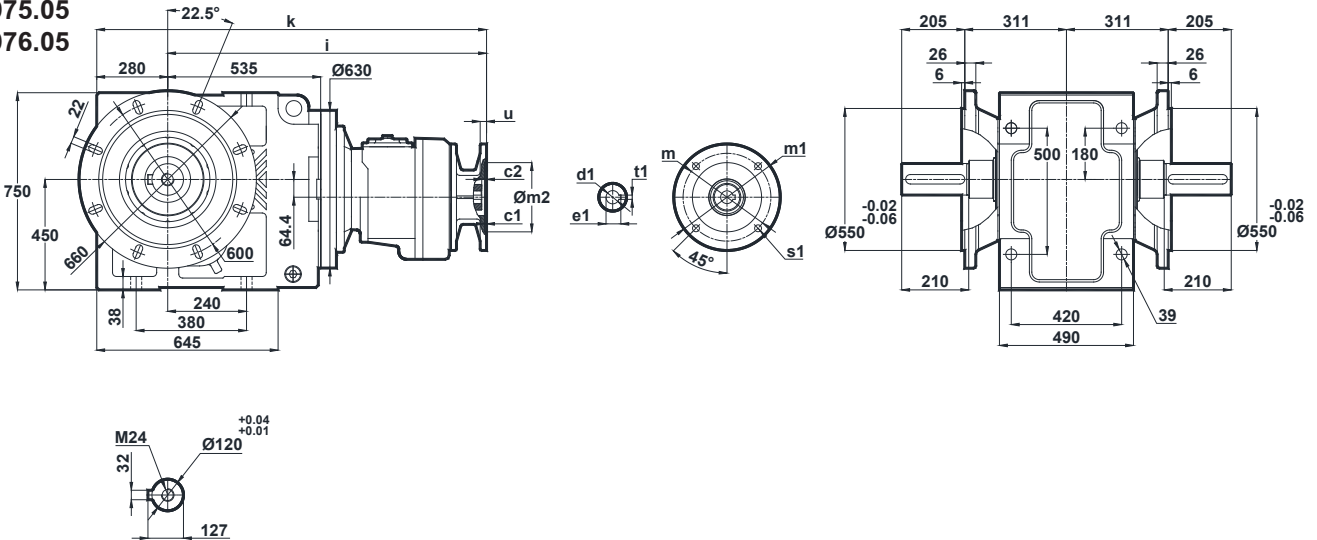

	c1	c2	s1	m	m1	m2	i	u	k	d1	t1	e1
80/B5 80/B14	4	4	12	165	200	130	891.5	12	1171.5	19	6	21.8
90/B5 90/B14	4	5	12	165	200	130	891.5	12	1171.5	24	8	27.3
100/B5 100/B14	5	9	15	215	250	180	910	15	1190	28	8	31.3
112/B5 112/B14	4.5	9	9	215	250	180	910	15	1190	28	8	31.3
132/B5 132/B14	4.5	9	15	265	300	230	928.5	15	1208.5	38	10	41.3

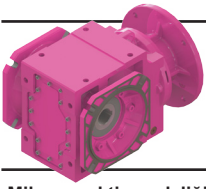

Ölçü Sayfaları

Dimension Pages

Abmessungsseiten

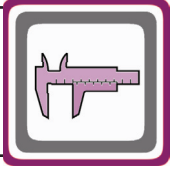

-Mil ucu çekirme deliği DIN 332 sayfa 2 / Tapped center hole to DIN 332, sheet 2 / Zentrierung mit Gewinde DIN 332, Blatt 2

KN975.08
KN976.08

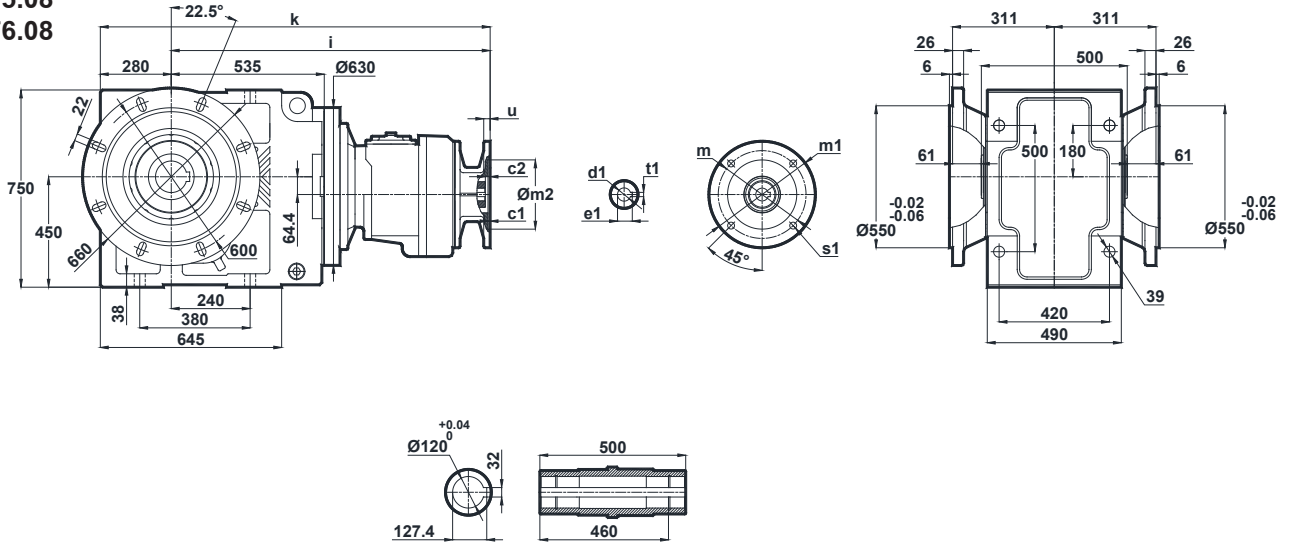

	c1	c2	s1	m	m1	m2	i	u	k	d1	t1	e1
80/B5 80/B14	4	4	12	165	200	130	891.5	12	1171.5	19	6	21.8
90/B5 90/B14	4	5	12 9	165 115	200 140	130 95	891.5	12	1171.5	24	8	27.3
100/B5 100/B14	5 4	9	15 9	215 130	250 160	180 110	910	15	1190	28	8	31.3
112/B5 112/B14	4.5	9	9	215 130	250 160	180 110	910	15	1190	28	8	31.3
132/B5 132/B14	4.5	9	15	265 165	300 200	230 130	928.5	15	1208.5	38	10	41.3

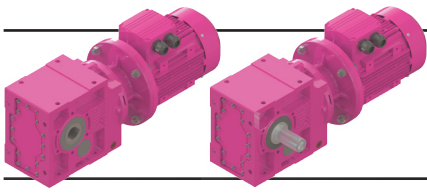

Ölçü Sayfaları

Dimension Pages

Abmessungsseiten

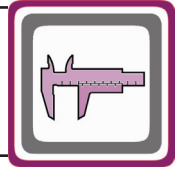

-Mil ucu çekirme deliği DIN 332 sayfa 2 / Tapped center hole to DIN 332, sheet 2 / Zentrierung mit Gewinde DIN 332, Blatt 2

KV002.00
KV003.00

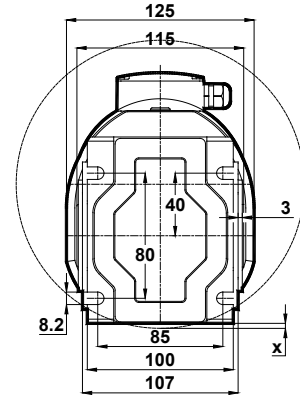
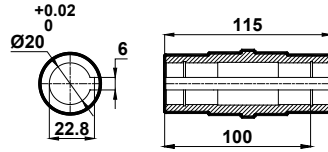
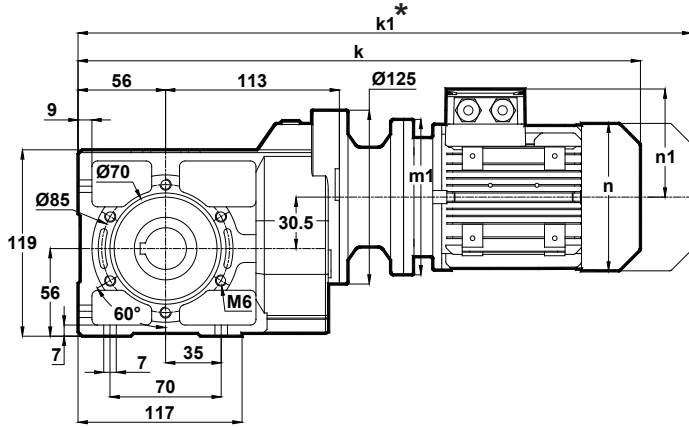

x: Motor ayak bağlantı yüzeyinin altında ise
x: If Motor is lower than foot mounting plane
x: Wenn der Motor unter der Fußmontageebene ist

	63/B5 63/B14	71/B5 71/B14	80/B5 80/B14	90S/B5 90S/B14	90L/B5 90L/B14
k	405	424.5	462.5	503.5	503.5
k1	466	515.5	555.5	607	607
n / n1	121 / 97	137 / 112	155 / 123	176 / 132	176 / 132
m1 (B5)	140	160	200	200	200
m1 (B14)	90	105	120	140	140
x	-	-	13,5	13,5	13,5

Klemens Pozisyonları
Terminal Box Positions
Klemmenkasten Positionen

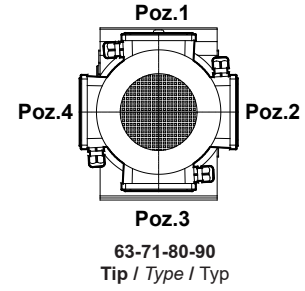

KV002.01
KV003.01

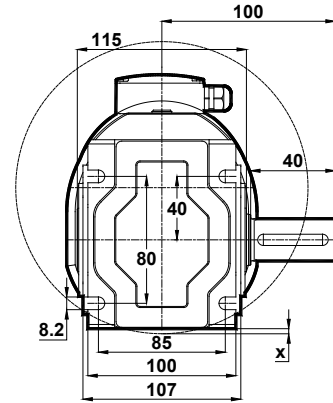
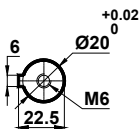
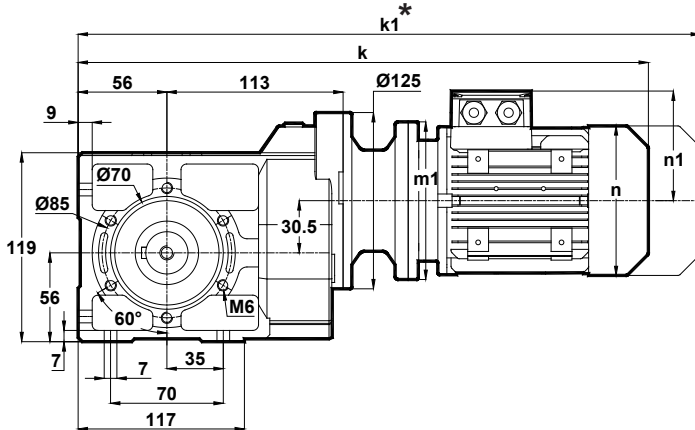

x: Motor ayak bağlantı yüzeyinin altında ise
x: If Motor is lower than foot mounting plane
x: Wenn der Motor unter der Fußmontageebene ist

	63/B5 63/B14	71/B5 71/B14	80/B5 80/B14	90S/B5 90S/B14	90L/B5 90L/B14
k	405	424.5	462.5	503.5	503.5
k1	466	515.5	555.5	607	607
n / n1	121 / 97	137 / 112	155 / 123	176 / 132	176 / 132
m1 (B5)	140	160	200	200	200
m1 (B14)	90	105	120	140	140
x	-	-	13,5	13,5	13,5

* " k1 " Ölçüsü frenli redüktörlere aittir.
Dimension " k1 " is for motors with brake.
Maße " k1 " ist für Bremsenmotoren.

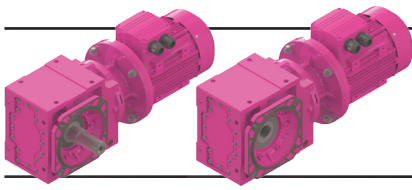

Ölçü Sayfaları

Dimension Pages

Abmessungsseiten

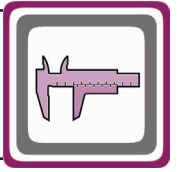

-Mil ucu çektirme deliği DIN 332 sayfa 2 / Tapped center hole to DIN 332, sheet 2 / Zentrierung mit Gewinde DIN 332, Blatt 2

KV002.02
KV003.02

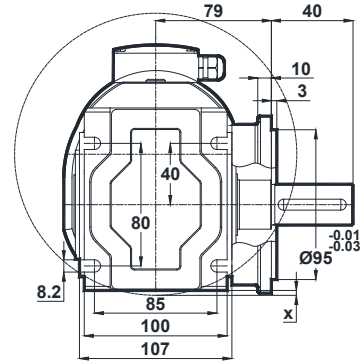
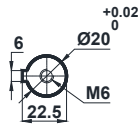
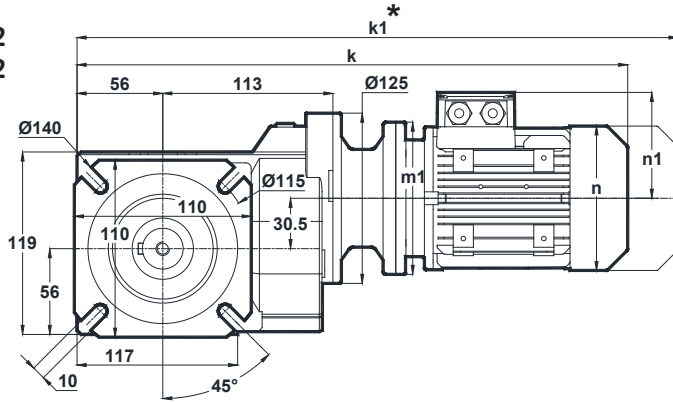

x: Motor Ayak bağlantı yüzeyinin altında ise
x: If Motor is lower than foot mounting plane
x: Wenn der Motor unter der Fußmontageebene ist

Klemens Pozisyonları
Terminal Box Positions
Klemmenkasten Positionen

	63/B5 63/B14	71/B5 71/B14	80/B5 80/B14	90S/B5 90S/B14	90L/B5 90L/B14
k	405	424.5	462.5	503.5	503.5
k1	466	515.5	555.5	607	607
n / n1	121 / 97	137 / 112	155 / 123	176 / 132	176 / 132
m1 (B5)	140	160	200	200	200
m1 (B14)	90	105	120	140	140
x	-	-	13,5	13,5	13,5

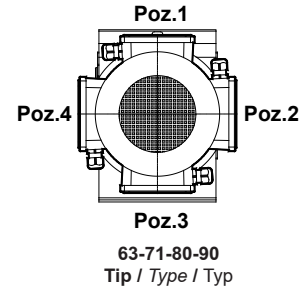

Opsiyonel flanş ölçüleri için sayfa 587'ye bakınız.
Please see on page 587 for optional flange dimensions
Siehe Seite 587 für auswählbare Flanschabmessungen

KV002.03
KV003.03

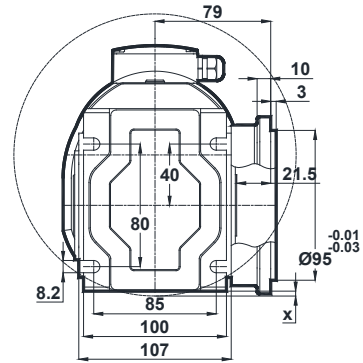
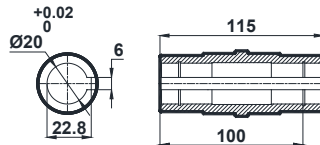
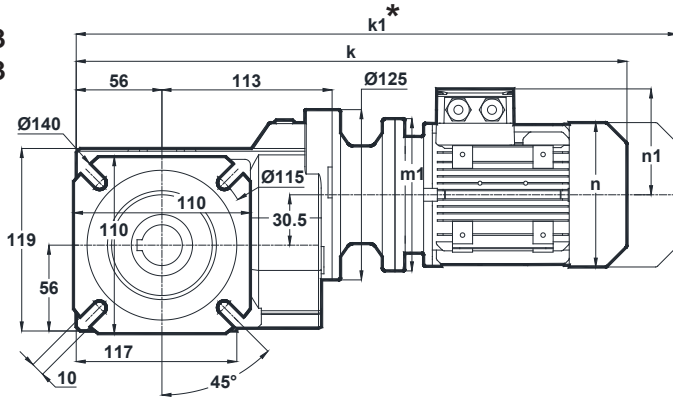

x: Motor Ayak bağlantı yüzeyinin altında ise
x: If Motor is lower than foot mounting plane
x: Wenn der Motor unter der Fußmontageebene ist

Opsiyonel flanş ölçüleri için sayfa 587'ye bakınız.
Please see on page 587 for optional flange dimensions
Siehe Seite 587 für auswählbare Flanschabmessungen

	63/B5 63/B14	71/B5 71/B14	80/B5 80/B14	90S/B5 90S/B14	90L/B5 90L/B14
k	405	424.5	462.5	503.5	503.5
k1	466	515.5	555.5	607	607
n / n1	121 / 97	137 / 112	155 / 123	176 / 132	176 / 132
m1 (B5)	140	160	200	200	200
m1 (B14)	90	105	120	140	140
x	-	-	13,5	13,5	13,5

* " k1 " Ölçüsü frenli redüktörlere aittir.
Dimension " k1 " is for motors with brake.
Maße " k1 " ist für Bremsenmotoren.

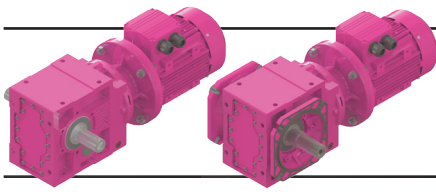

Ölçü Sayfaları Dimension Pages Abmessungsseiten

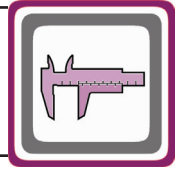

-Mil ucu çektirme deliği DIN 332 sayfa 2 / Tapped center hole to DIN 332, sheet 2 / Zentrierung mit Gewinde DIN 332, Blatt 2

KV002.04
KV003.04

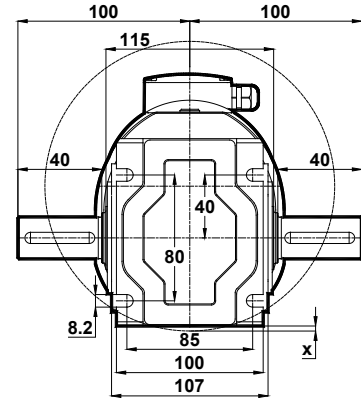
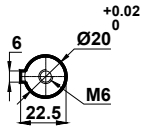
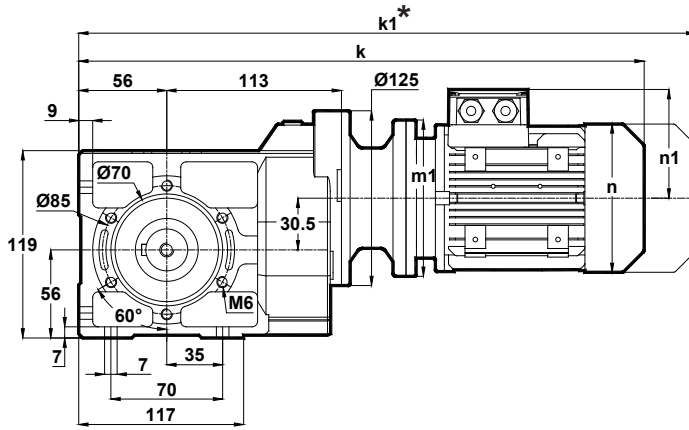

x: Motor Ayak bağlantı yüzeyinin altında ise
x: If Motor is lower than foot mounting plane
x: Wenn der Motor unter der Fußmontageebene ist

	63/B5 63/B14	71/B5 71/B14	80/B5 80/B14	90S/B5 90S/B14	90L/B5 90L/B14
k	405	424.5	462.5	503.5	503.5
k1	466	515.5	555.5	607	607
n / n1	121 / 97	137 / 112	155 / 123	176 / 132	176 / 132
m1 (B5)	140	160	200	200	200
m1 (B14)	90	105	120	140	140
x	-	-	13,5	13,5	13,5

Klemens Pozisyonları
Terminal Box Positions
Klemmenkasten Positionen

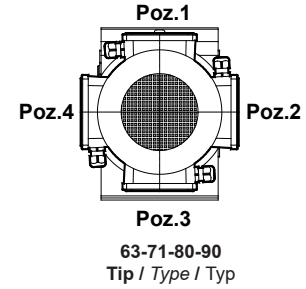

KV002.05
KV003.05

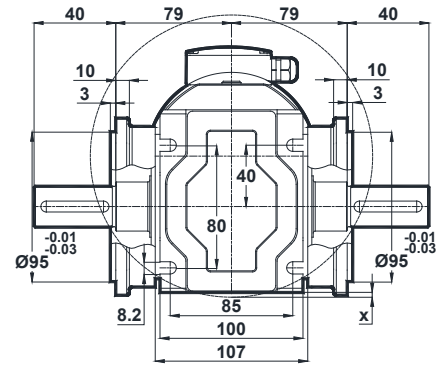
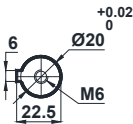
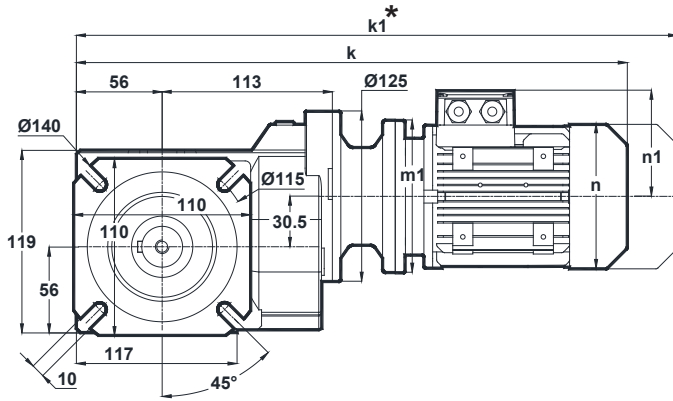

x: Motor Ayak bağlantı yüzeyinin altında ise
x: If Motor is lower than foot mounting plane
x: Wenn der Motor unter der Fußmontageebene ist

	63/B5 63/B14	71/B5 71/B14	80/B5 80/B14	90S/B5 90S/B14	90L/B5 90L/B14
k	405	424.5	462.5	503.5	503.5
k1	466	515.5	555.5	607	607
n / n1	121 / 97	137 / 112	155 / 123	176 / 132	176 / 132
m1 (B5)	140	160	200	200	200
m1 (B14)	90	105	120	140	140
x	-	-	13,5	13,5	13,5

Opsiyonel flanş ölçüleri için sayfa 587'ye bakınız.
Please see on page 587 for optional flange dimensions
Siehe Seite 587 für auswählbare Flanschabmessungen

* " k1 " Ölçüsü frenli redüktörlere aittir.
Dimension " k1 " is for motors with brake.
Maße " k1 " ist für Bremsenmotoren.

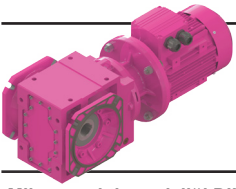

Ölçü Sayfaları Dimension Pages Abmessungsseiten



-Mil ucu çektirme deliği DIN 332 sayfa 2 / Tapped center hole to DIN 332, sheet 2 / Zentrierung mit Gewinde DIN 332, Blatt 2

KV002.08
KV003.08

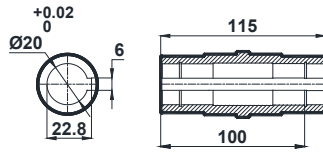
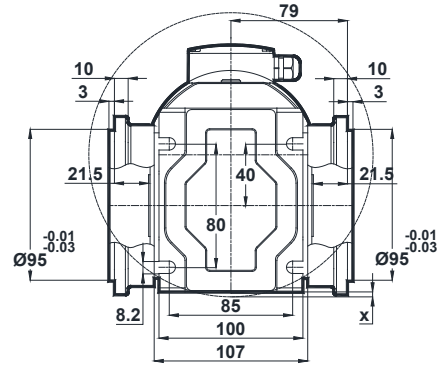
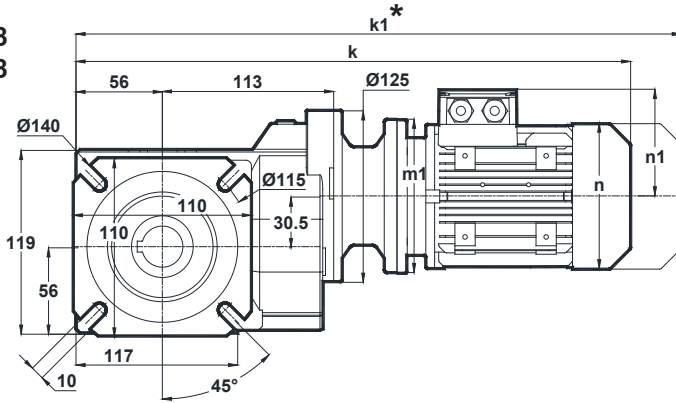

x: Motor ayak bağlantı yüzeyinin altında ise
x: If Motor is lower than foot mounting plane
x: Wenn der Motor unter der Fußmontageebene ist

	63/B5 63/B14	71/B5 71/B14	80/B5 80/B14	90S/B5 90S/B14	90L/B5 90L/B14
k	405	424.5	462.5	503.5	503.5
k1	466	515.5	555.5	607	607
n / n1	121 / 97	137 / 112	155 / 123	176 / 132	176 / 132
m1 (B5)	140	160	200	200	200
m1 (B14)	90	105	120	140	140
x	-	-	13,5	13,5	13,5

Klemens Pozisyonları
Terminal Box Positions
Klemmenkasten Positionen

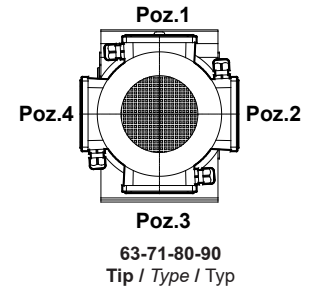

Opsiyonel flanş ölçüleri için sayfa 587'ye bakınız.
Please see on page 587 for optional flange dimensions
Siehe Seite 587 für auswählbare Flanschabmessungen

* " k1 " Ölçüsü frenli redüktörlere aittir.
Dimension " k1 " is for motors with brake.
Maße " k1 " ist für Bremsenmotoren.

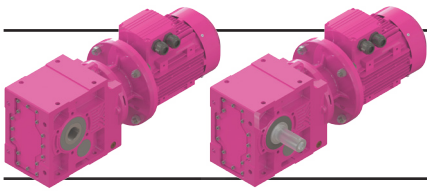

Ölçü Sayfaları

Dimension Pages

Abmessungsseiten

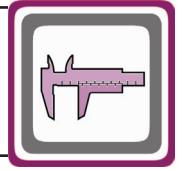

-Mil ucu çekirme deliği DIN 332 sayfa 2 / Tapped center hole to DIN 332, sheet 2 / Zentrierung mit Gewinde DIN 332, Blatt 2

KV102.00
KV103.00

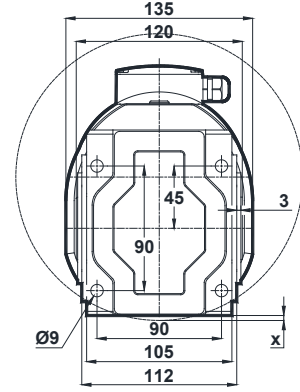
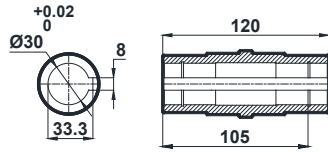
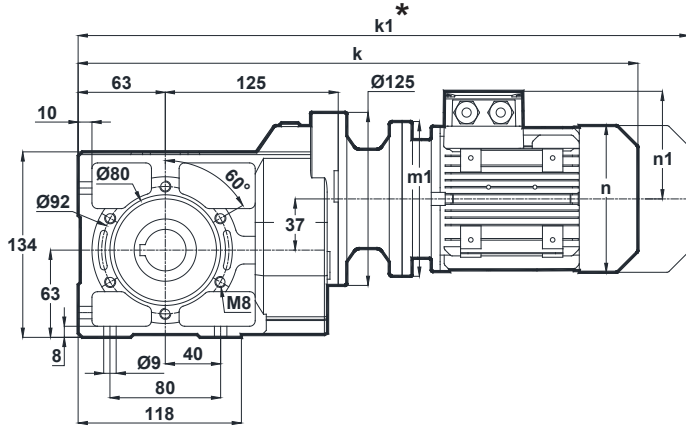

x: Motor ayak bağlantı yüzeyinin altında ise
x: If Motor is lower than foot mounting plane
x: Wenn der Motor unter der Fußmontageebene ist

	63/B5 63/B14	71/B5 71/B14	80/B5 80/B14	90S/B5 90S/B14	90L/B5 90L/B14
k	424	443.5	481.5	522.5	522.5
k1	485	534.5	574.5	626	626
n / n1	121 / 97	137 / 112	155 / 123	176 / 132	176 / 132
m1 (B5)	140	160	200	200	200
m1 (B14)	90	105	120	140	140
x	-	-	-	-	-

Klemens Pozisyonları
Terminal Box Positions
Klemmenkasten Positionen

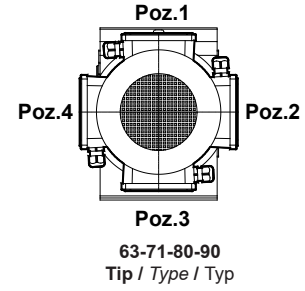

KV102.01
KV103.01

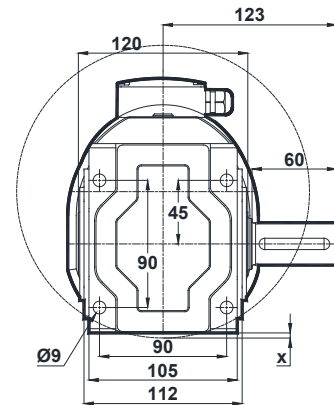
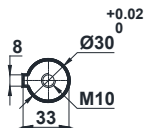
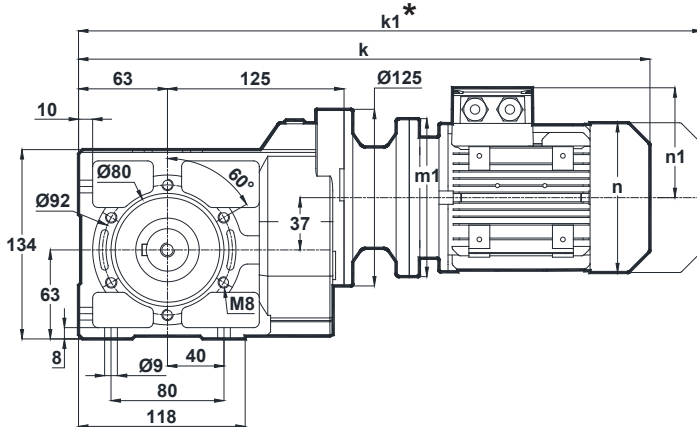

x: Motor ayak bağlantı yüzeyinin altında ise
x: If Motor is lower than foot mounting plane
x: Wenn der Motor unter der Fußmontageebene ist

	63/B5 63/B14	71/B5 71/B14	80/B5 80/B14	90S/B5 90S/B14	90L/B5 90L/B14
k	424	443.5	481.5	522.5	522.5
k1	485	534.5	574.5	626	626
n / n1	121 / 97	137 / 112	155 / 123	176 / 132	176 / 132
m1 (B5)	140	160	200	200	200
m1 (B14)	90	105	120	140	140
x	-	-	-	-	-

* " k1 " Ölçüsü frenli redüktörlere aittir.
Dimension " k1 " is for motors with brake.
Maße " k1 " ist für Bremsenmotoren.

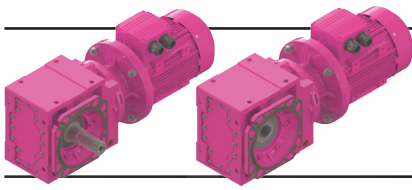

Ölçü Sayfaları

Dimension Pages

Abmessungsseiten

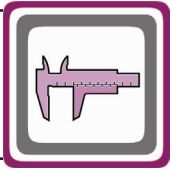

-Mil ucu çektirme deliği DIN 332 sayfa 2 / Tapped center hole to DIN 332, sheet 2 / Zentrierung mit Gewinde DIN 332, Blatt 2

KV102.02
KV103.02

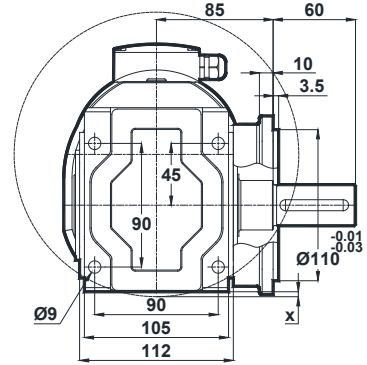
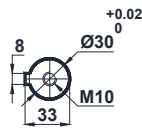
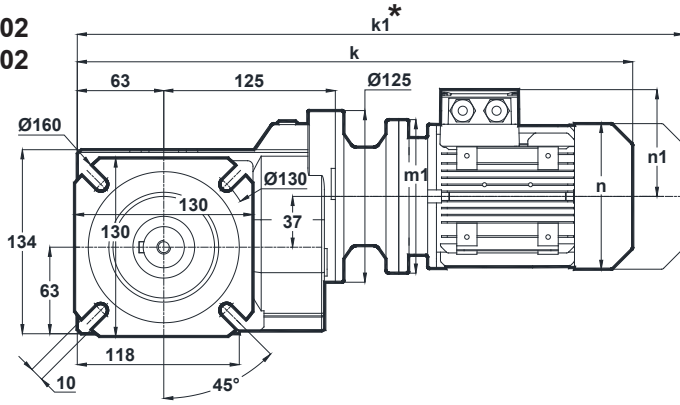

x: Motor Ayak bağlantı yüzeyinin altında ise
x: If Motor is lower than foot mounting plane
x: Wenn der Motor unter der Fußmontageebene ist

Klemens Pozisyonları
Terminal Box Positions
Klemmenkasten Positionen

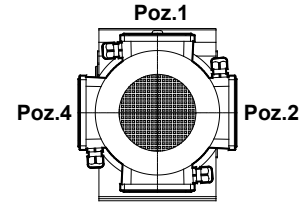

63-71-80-90
Tip / Type / Typ

Opsiyonel flanş ölçüleri için sayfa 587'ye bakınız.
Please see on page 587 for optional flange dimensions
Siehe Seite 587 für auswählbare Flanschabmessungen

	63/B5 63/B14	71/B5 71/B14	80/B5 80/B14	90S/B5 90S/B14	90L/B5 90L/B14
k	424	443.5	481.5	522.5	522.5
k1	485	534.5	574.5	626	626
n / n1	121 / 97	137 / 112	155 / 123	176 / 132	176 / 132
m1 (B5)	140	160	200	200	200
m1 (B14)	90	105	120	140	140
x	-	-	-	-	-

KV102.03
KV103.03

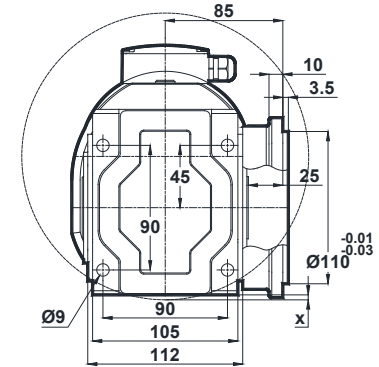
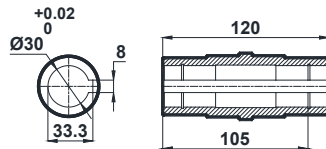
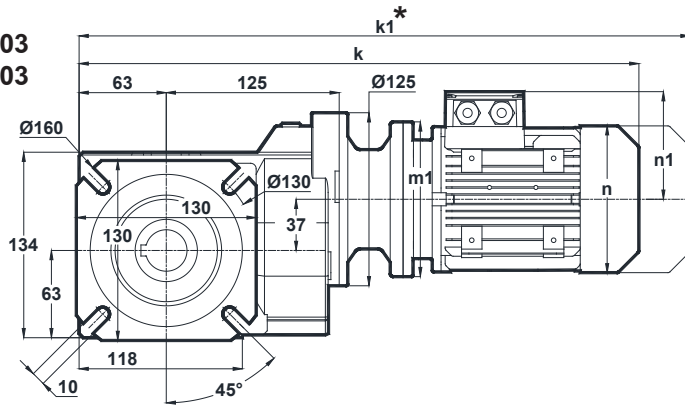

x: Motor Ayak bağlantı yüzeyinin altında ise
x: If Motor is lower than foot mounting plane
x: Wenn der Motor unter der Fußmontageebene ist

Opsiyonel flanş ölçüleri için sayfa 587'ye bakınız.
Please see on page 587 for optional flange dimensions
Siehe Seite 587 für auswählbare Flanschabmessungen

	63/B5 63/B14	71/B5 71/B14	80/B5 80/B14	90S/B5 90S/B14	90L/B5 90L/B14
k	424	443.5	481.5	522.5	522.5
k1	485	534.5	574.5	626	626
n / n1	121 / 97	137 / 112	155 / 123	176 / 132	176 / 132
m1 (B5)	140	160	200	200	200
m1 (B14)	90	105	120	140	140
x	-	-	-	-	-

* " k1 " Ölçüsü frenli redüktörlere aittir.
Dimension " k1 " is for motors with brake.
Maße " k1 " ist für Bremsenmotoren.

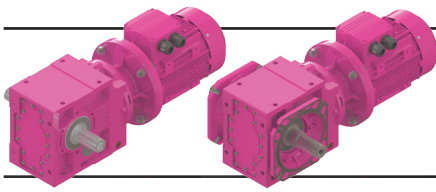

Ölçü Sayfaları

Dimension Pages

Abmessungsseiten

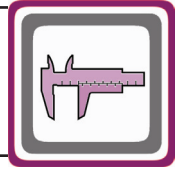

-Mil ucu çektirme deliği DIN 332 sayfa 2 / Tapped center hole to DIN 332, sheet 2 / Zentrierung mit Gewinde DIN 332, Blatt 2

KV102.04
KV103.04

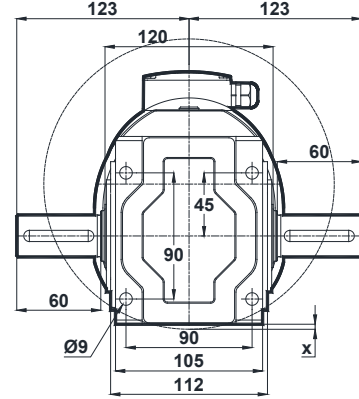
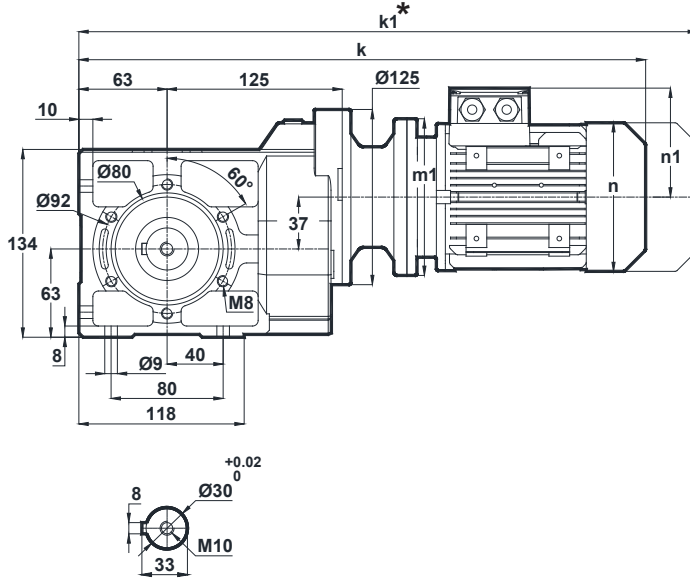

x: Motor Ayak bağlantı yüzeyinin altında ise
x: If Motor is lower than foot mounting plane
x: Wenn der Motor unter der Fußmontageebene ist

Klemens Pozisyonları
Terminal Box Positions
Klemmenkasten Positionen

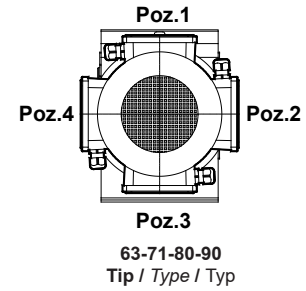

	63/B5 63/B14	71/B5 71/B14	80/B5 80/B14	90S/B5 90S/B14	90L/B5 90L/B14
k	424	443.5	481.5	522.5	522.5
k1	485	534.5	574.5	626	626
n / n1	121 / 97	137 / 112	155 / 123	176 / 132	176 / 132
m1 (B5)	140	160	200	200	200
m1 (B14)	90	105	120	140	140
x	-	-	-	-	-

KV102.05
KV103.05

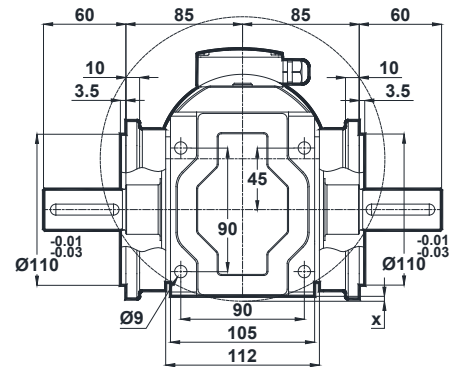
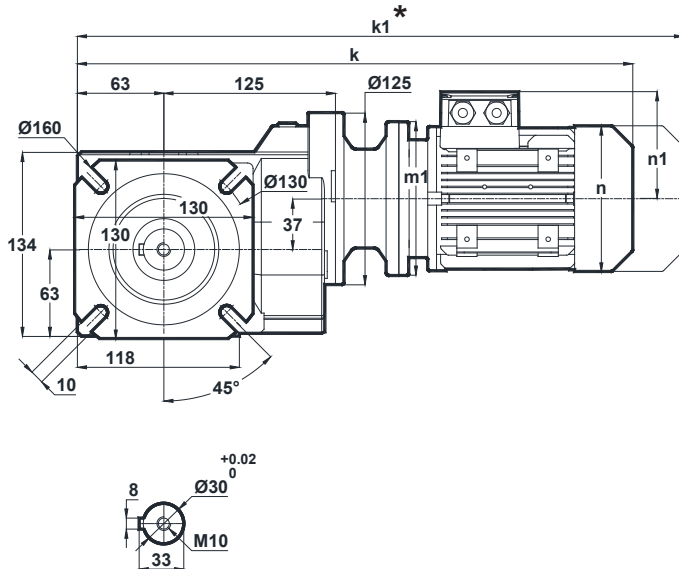

x: Motor Ayak bağlantı yüzeyinin altında ise
x: If Motor is lower than foot mounting plane
x: Wenn der Motor unter der Fußmontageebene ist

Opsiyonel flanş ölçüleri için sayfa 587'ye bakınız.
Please see on page 587 for optional flange dimensions
Siehe Seite 587 für auswählbare Flanschabmessungen

	63/B5 63/B14	71/B5 71/B14	80/B5 80/B14	90S/B5 90S/B14	90L/B5 90L/B14
k	424	443.5	481.5	522.5	522.5
k1	485	534.5	574.5	626	626
n / n1	121 / 97	137 / 112	155 / 123	176 / 132	176 / 132
m1 (B5)	140	160	200	200	200
m1 (B14)	90	105	120	140	140
x	-	-	-	-	-

* " k1 " Ölçüsü frenli redüktörlere aittir.
Dimension " k1 " is for motors with brake.
Maße " k1 " ist für Bremsenmotoren.

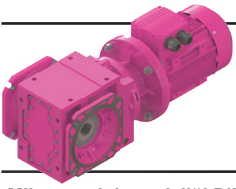

Ölçü Sayfaları Dimension Pages Abmessungsseiten

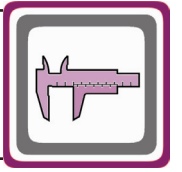

-Mil ucu çekirme deliği DIN 332 sayfa 2 / Tapped center hole to DIN 332, sheet 2 / Zentrierung mit Gewinde DIN 332, Blatt 2

KV102.08
KV103.08

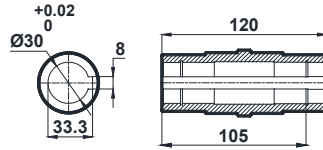
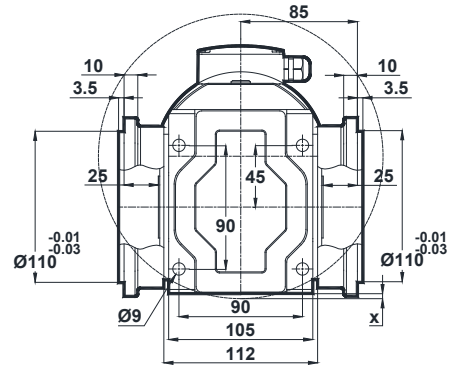
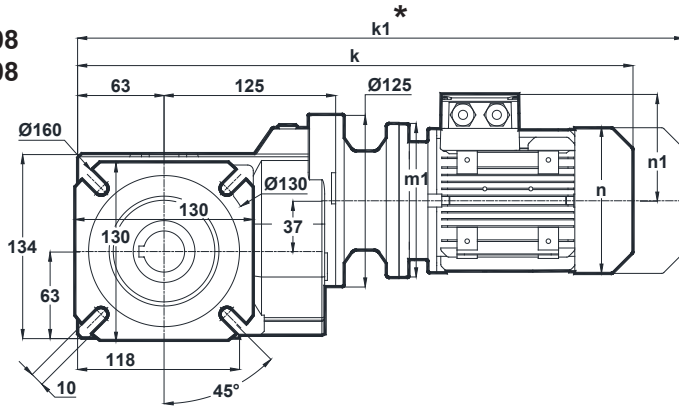

x: Motor Ayak bağlantı yüzeyinin altında ise
x: If Motor is lower than foot mounting plane
x: Wenn der Motor unter der Fußmontageebene ist

Klemens Pozisyonları
Terminal Box Positions
Klemmenkasten Positionen

	63/B5 63/B14	71/B5 71/B14	80/B5 80/B14	90S/B5 90S/B14	90L/B5 90L/B14
k	424	443.5	481.5	522.5	522.5
k1	485	534.5	574.5	626	626
n / n1	121 / 97	137 / 112	155 / 123	176 / 132	176 / 132
m1 (B5)	140	160	200	200	200
m1 (B14)	90	105	120	140	140
x	-	-	-	-	-

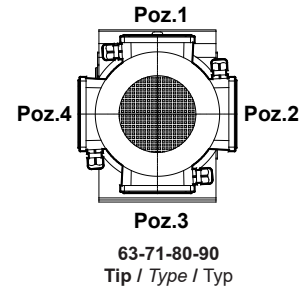

Opsiyonel flanş ölçüleri için sayfa 587'ye bakınız.
Please see on page 587 for optional flange dimensions
Siehe Seite 587 für auswählbare Flanschabmessungen

* " k1 " Ölçüsü frenli redüktörlere aittir.
Dimension " k1 " is for motors with brake.
Maße " k1 " ist für Bremsenmotoren.

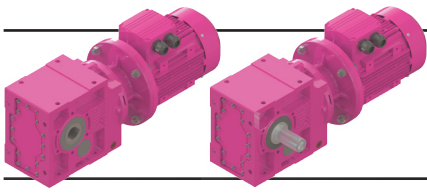

Ölçü Sayfaları

Dimension Pages

Abmessungsseiten

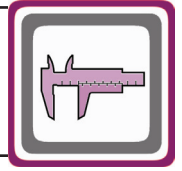

-Mil ucu çektirme deliği DIN 332 sayfa 2 / Tapped center hole to DIN 332, sheet 2 / Zentrierung mit Gewinde DIN 332, Blatt 2

KV202.00
KV203.00

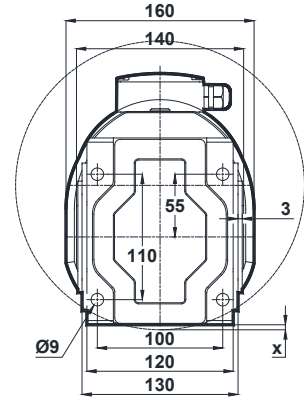
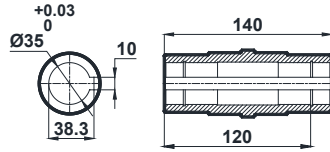
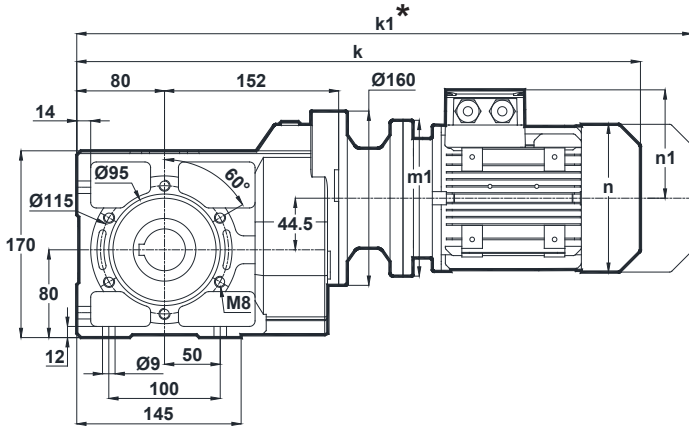

x: Motor ayak bağlantı yüzeyinin altında ise
x: If Motor is lower than foot mounting plane
x: Wenn der Motor unter der Fußmontageebene ist

	63/B5	71/B5 71/B14	80/B5 80/B14	90S/B5 90S/B14	90L/B5 90L/B14	100L/B5 100L/B14	112M/B5 112M/B14
k	498.5	487.5	539.5	580.5	580.5	609	629.5
k1	559.5	578.5	632.5	684	684	717.5	734
n / n1	121 / 97	137 / 112	155 / 123	176 / 132	176 / 132	193 / 149	215 / 161
m1 (B5)	140	160	200	200	200	250	250
m1 (B14)	-	105	120	140	140	160	160
x	-	-	-	-	-	0,5	0,5

Klemens Pozisyonları
Terminal Box Positions
Klemmenkasten Positionen

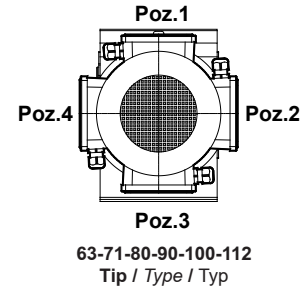

KV202.01
KV203.01

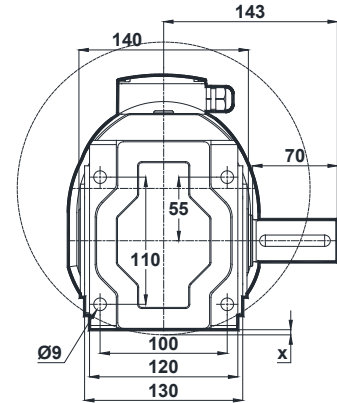
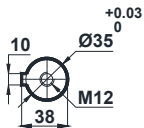
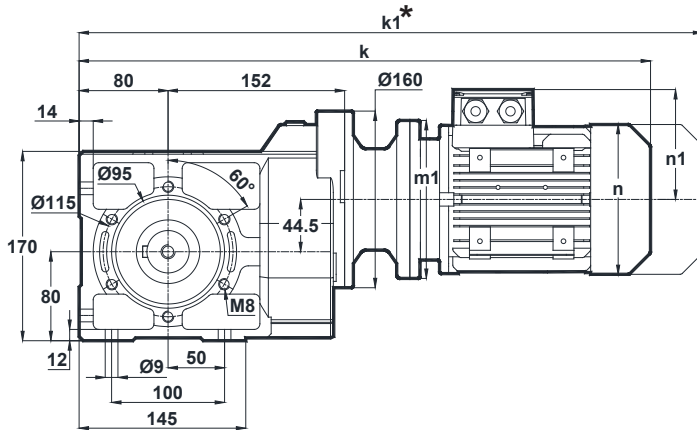

x: Motor ayak bağlantı yüzeyinin altında ise
x: If Motor is lower than foot mounting plane
x: Wenn der Motor unter der Fußmontageebene ist

	63/B5	71/B5 71/B14	80/B5 80/B14	90S/B5 90S/B14	90L/B5 90L/B14	100L/B5 100L/B14	112M/B5 112M/B14
k	498.5	487.5	539.5	580.5	580.5	609	629.5
k1	559.5	578.5	632.5	684	684	717.5	734
n / n1	121 / 97	137 / 112	155 / 123	176 / 132	176 / 132	193 / 149	215 / 161
m1 (B5)	140	160	200	200	200	250	250
m1 (B14)	-	105	120	140	140	160	160
x	-	-	-	-	-	0,5	0,5

* " k1 " Ölçüsü frenli redüktörlere aittir.
Dimension " k1 " is for motors with brake.
Maße " k1 " ist für Bremsenmotoren.

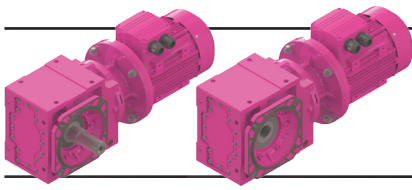

Ölçü Sayfaları

Dimension Pages

Abmessungsseiten



-Mil ucu çektirme deliği DIN 332 sayfa 2 / Tapped center hole to DIN 332, sheet 2 / Zentrierung mit Gewinde DIN 332, Blatt 2

KV202.02
KV203.02

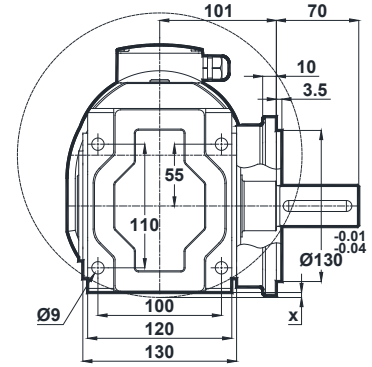
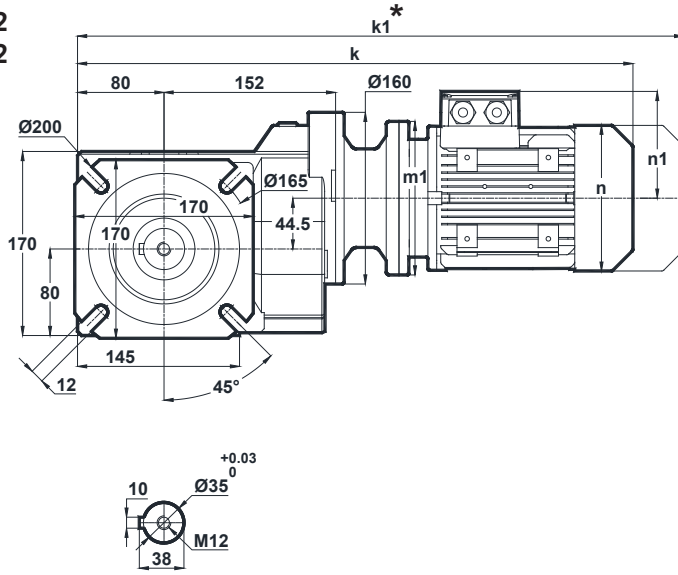

x: Motor Ayak bağlantı yüzeyinin altında ise
x: If Motor is lower than foot mounting plane
x: Wenn der Motor unter der Fußmontageebene ist

Klemens Pozisyonları
Terminal Box Positions
Klemmenkasten Positionen

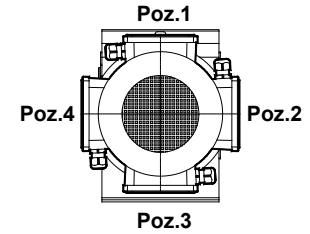

63-71-80-90-100-112
Tip / Type / Typ

Opsiyonel flanş ölçüleri için sayfa 587'ye bakınız.
Please see on page 587 for optional flange dimensions
Siehe Seite 587 für auswählbare Flanschabmessungen

	63/B5	71/B5 71/B14	80/B5 80/B14	90S/B5 90S/B14	90L/B5 90L/B14	100L/B5 100L/B14	112M/B5 112M/B14
k	498.5	487.5	539.5	580.5	580.5	609	629.5
k1	559.5	578.5	632.5	684	684	717.5	734
n / n1	121 / 97	137 / 112	155 / 123	176 / 132	176 / 132	193 / 149	215 / 161
m1 (B5)	140	160	200	200	200	250	250
m1 (B14)	-	105	120	140	140	160	160
x	-	-	-	-	-	0,5	0,5

KV202.03
KV203.03

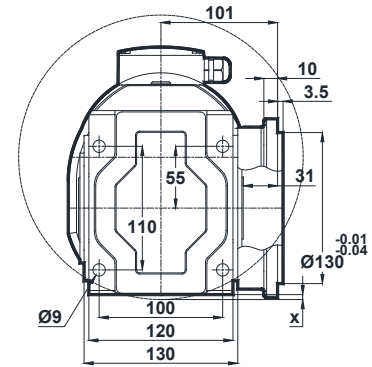
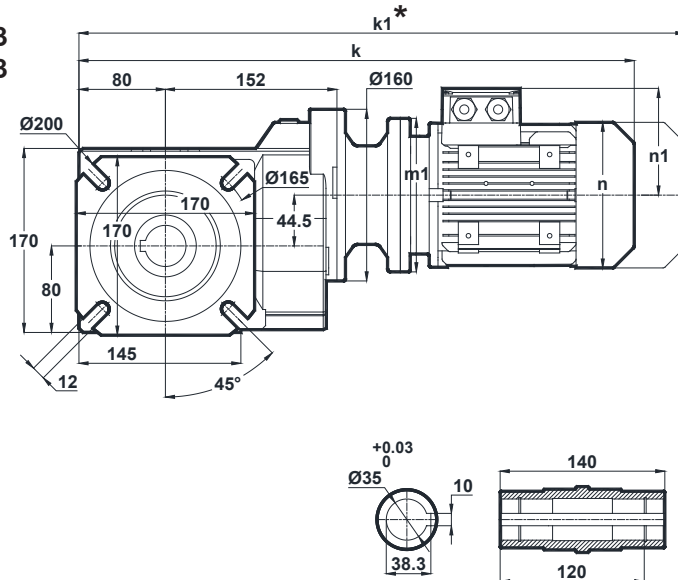

x: Motor Ayak bağlantı yüzeyinin altında ise
x: If Motor is lower than foot mounting plane
x: Wenn der Motor unter der Fußmontageebene ist

	63/B5	71/B5 71/B14	80/B5 80/B14	90S/B5 90S/B14	90L/B5 90L/B14	100L/B5 100L/B14	112M/B5 112M/B14
k	498.5	487.5	539.5	580.5	580.5	609	629.5
k1	559.5	578.5	632.5	684	684	717.5	734
n / n1	121 / 97	137 / 112	155 / 123	176 / 132	176 / 132	193 / 149	215 / 161
m1 (B5)	140	160	200	200	200	250	250
m1 (B14)	-	105	120	140	140	160	160
x	-	-	-	-	-	0,5	0,5

Opsiyonel flanş ölçüleri için sayfa 587'ye bakınız.
Please see on page 587 for optional flange dimensions
Siehe Seite 587 für auswählbare Flanschabmessungen

* " k1 " Ölçüsü frenli redüktörlere aittir.
Dimension " k1 " is for motors with brake.
Maße " k1 " ist für Bremsenmotoren.

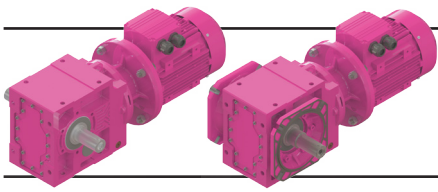

Ölçü Sayfaları Dimension Pages Abmessungenseiten

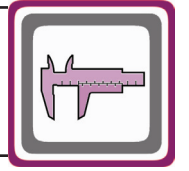

-Mil ucu çektirme deliği DIN 332 sayfa 2 / Tapped center hole to DIN 332, sheet 2 / Zentrierung mit Gewinde DIN 332, Blatt 2

KV202.04
KV203.04

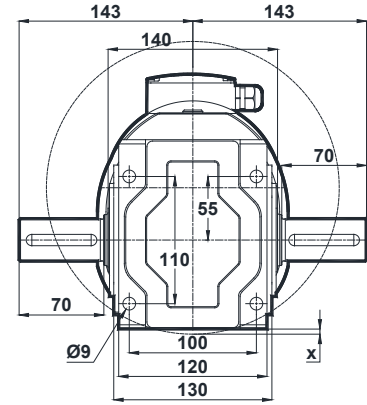
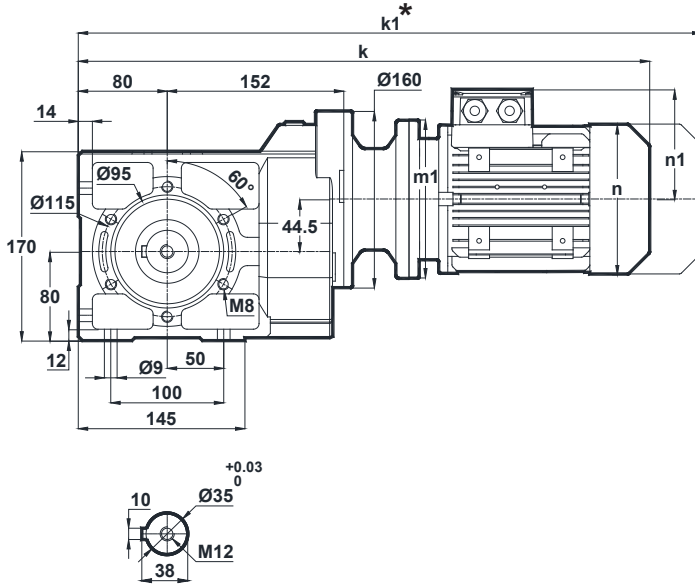

x: Motor Ayak bağlantı yüzeyinin altında ise
x: If Motor is lower than foot mounting plane
x: Wenn der Motor unter der Fußmontageebene ist

Klemens Pozisyonları
Terminal Box Positions
Klemmenkasten Positionen

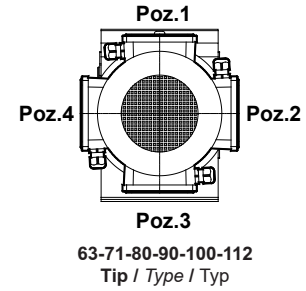

	63/B5	71/B5 71/B14	80/B5 80/B14	90S/B5 90S/B14	90L/B5 90L/B14	100L/B5 100L/B14	112M/B5 112M/B14
k	498.5	487.5	539.5	580.5	580.5	609	629.5
k1	559.5	578.5	632.5	684	684	717.5	734
n / n1	121 / 97	137 / 112	155 / 123	176 / 132	176 / 132	193 / 149	215 / 161
m1 (B5)	140	160	200	200	200	250	250
m1 (B14)	-	105	120	140	140	160	160
x	-	-	-	-	-	0,5	0,5

KV202.05
KV203.05

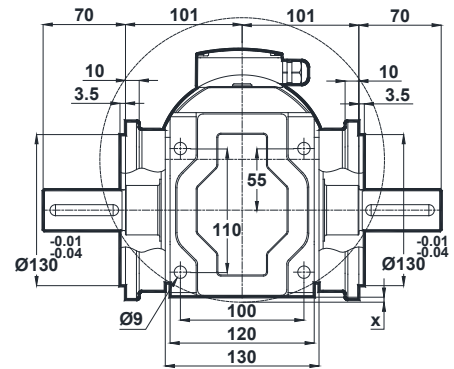
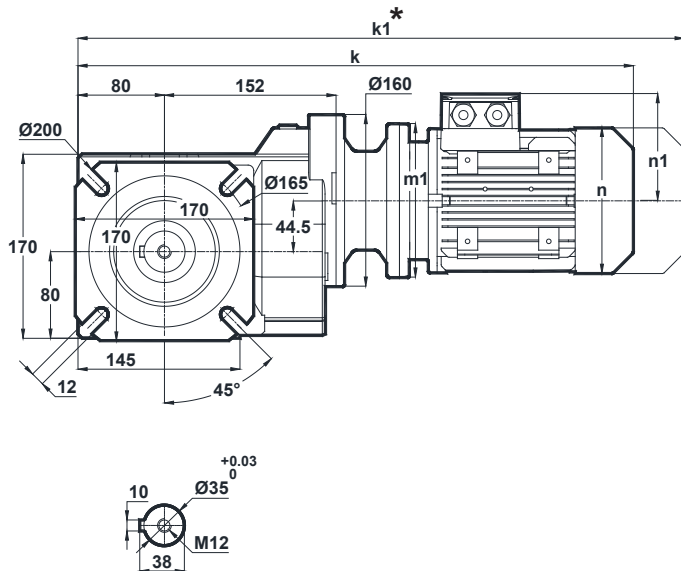

x: Motor Ayak bağlantı yüzeyinin altında ise
x: If Motor is lower than foot mounting plane
x: Wenn der Motor unter der Fußmontageebene ist

Opsiyonel flanş ölçüleri için sayfa 587'ye bakınız.
Please see on page 587 for optional flange dimensions
Siehe Seite 587 für auswählbare Flanschabmessungen

	63/B5	71/B5 71/B14	80/B5 80/B14	90S/B5 90S/B14	90L/B5 90L/B14	100L/B5 100L/B14	112M/B5 112M/B14
k	498.5	487.5	539.5	580.5	580.5	609	629.5
k1	559.5	578.5	632.5	684	684	717.5	734
n / n1	121 / 97	137 / 112	155 / 123	176 / 132	176 / 132	193 / 149	215 / 161
m1 (B5)	140	160	200	200	200	250	250
m1 (B14)	-	105	120	140	140	160	160
x	-	-	-	-	-	0,5	0,5

* " k1 " Ölçüsü frenli redüktörlere aittir.
Dimension " k1 " is for motors with brake.
Maße " k1 " ist für Bremsenmotoren.

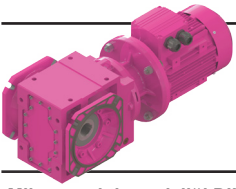

Ölçü Sayfaları Dimension Pages Abmessungsseiten



-Mil ucu çektirme deliği DIN 332 sayfa 2 / Tapped center hole to DIN 332, sheet 2 / Zentrierung mit Gewinde DIN 332, Blatt 2

KV202.08
KV203.08

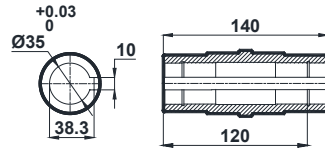
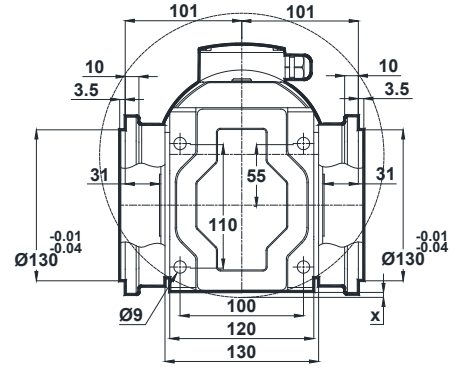
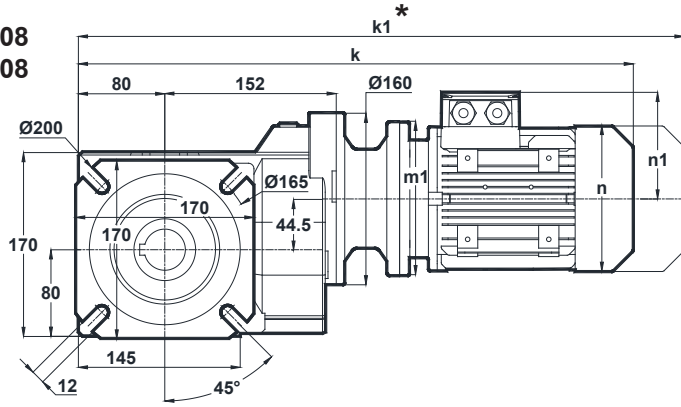

x: Motor Ayak bağlantı yüzeyinin altında ise
x: If Motor is lower than foot mounting plane
x: Wenn der Motor unter der Fußmontageebene ist

Klemens Pozisyonları
Terminal Box Positions
Klemmenkasten Positionen

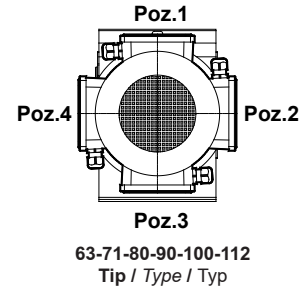

	63/B5	71/B5 71/B14	80/B5 80/B14	90S/B5 90S/B14	90L/B5 90L/B14	100L/B5 100L/B14	112M/B5 112M/B14
k	498.5	487.5	539.5	580.5	580.5	609	629.5
k1	559.5	578.5	632.5	684	684	717.5	734
n / n1	121 / 97	137 / 112	155 / 123	176 / 132	176 / 132	193 / 149	215 / 161
m1 (B5)	140	160	200	200	200	250	250
m1 (B14)	-	105	120	140	140	160	160
x	-	-	-	-	-	0,5	0,5

Opsiyonel flanş ölçüleri için sayfa 587'ye bakınız.
Please see on page 587 for optional flange dimensions
Siehe Seite 587 für auswählbare Flanschabmessungen

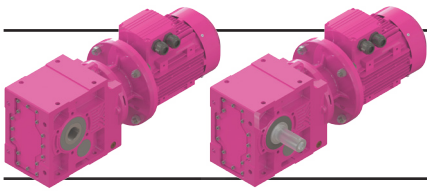

Ölçü Sayfaları Dimension Pages Abmessungsseiten

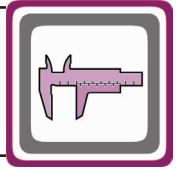

-Mil ucu çekirme deliği DIN 332 sayfa 2 / Tapped center hole to DIN 332, sheet 2 / Zentrierung mit Gewinde DIN 332, Blatt 2

KV273.00

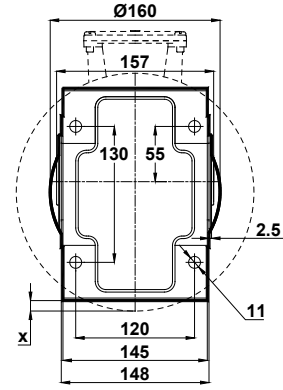
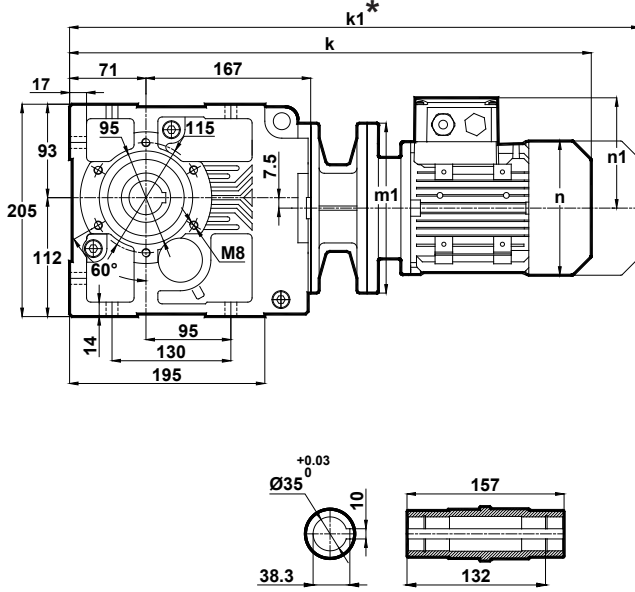

x: Motor Ayak bağlantı yüzeyinin altında ise
x: If Motor is lower than foot mounting plane
x: Wenn der Motor unter der Fußmontageebene ist

Klemens Pozisyonları
Terminal Box Positions
Klemmenkasten Positionen

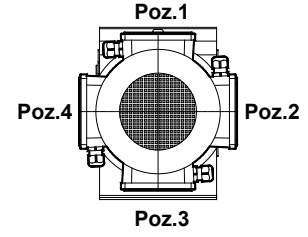

63-71-80-90-100-112
Tip / Type / Typ

	63/B5	71/B5 71/B14	80/B5 80/B14	90S/B5 90S/B14	90L/B5 90L/B14	100L/B5 100L/B14	112M/B5 112M/B14
k	504.5	493.5	545.5	586.5	586.5	615	635.5
k1	565.5	584.5	638.5	690	690	723.5	740
n / n1	121 / 97	137 / 112	155 / 123	176 / 132	176 / 132	193 / 149	215 / 161
m1 (B5)	140	160	200	200	200	250	250
m1 (B14)	-	105	120	140	140	160	160
x	-	-	-	-	-	20,5	20,5

KV273.01

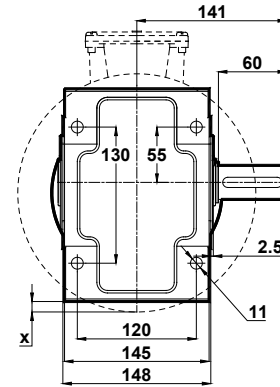
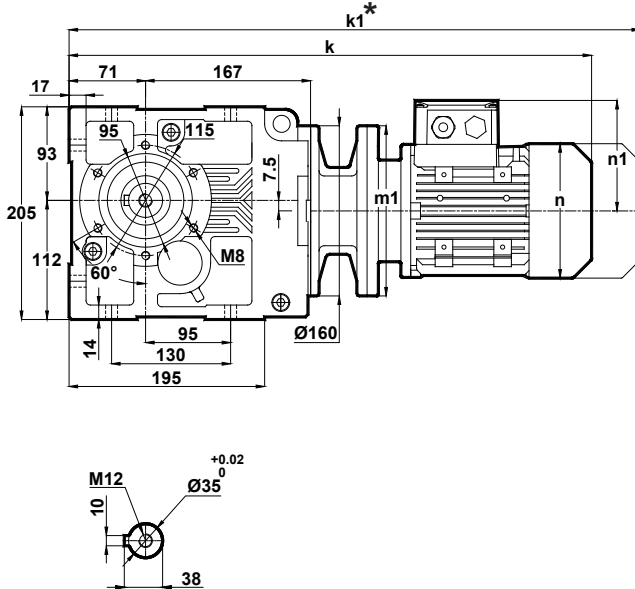

x: Motor Ayak bağlantı yüzeyinin altında ise
x: If Motor is lower than foot mounting plane
x: Wenn der Motor unter der Fußmontageebene ist

	63/B5	71/B5 71/B14	80/B5 80/B14	90S/B5 90S/B14	90L/B5 90L/B14	100L/B5 100L/B14	112M/B5 112M/B14
k	504.5	493.5	545.5	586.5	586.5	615	635.5
k1	565.5	584.5	638.5	690	690	723.5	740
n / n1	121 / 97	137 / 112	155 / 123	176 / 132	176 / 132	193 / 149	215 / 161
m1 (B5)	140	160	200	200	200	250	250
m1 (B14)	-	105	120	140	140	160	160
x	-	-	-	-	-	20,5	20,5

* " k1 " Ölçüsü frenli redüktörlere aittir.
Dimension " k1 " is for motors with brake.
Maße " k1 " ist für Bremsenmotoren.

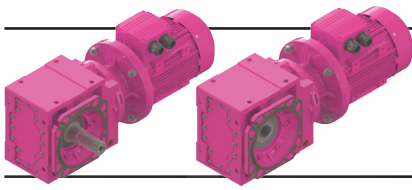

Ölçü Sayfaları

Dimension Pages

Abmessungsseiten

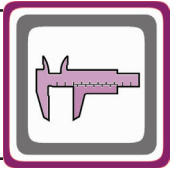

-Mil ucu çektirme deliği DIN 332 sayfa 2 / Tapped center hole to DIN 332, sheet 2 / Zentrierung mit Gewinde DIN 332, Blatt 2

KV273.02

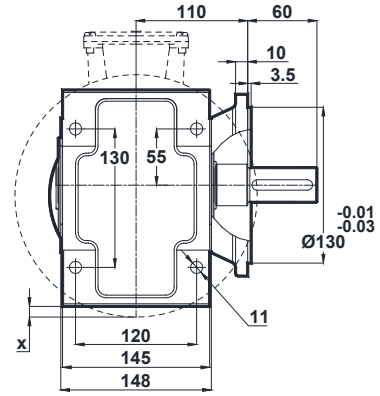
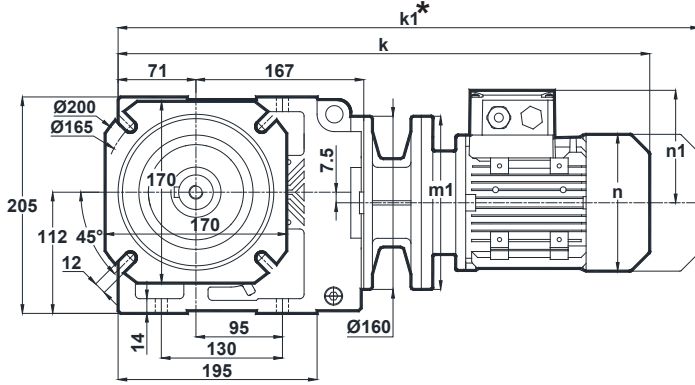

x: Motor Ayak bağlantı yüzeyinin altında ise
x: If Motor is lower than foot mounting plane
x: Wenn der Motor unter der Fußmontageebene ist

Klemens Pozisyonları
Terminal Box Positions
Klemmenkasten Positionen

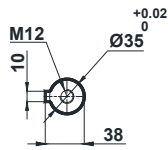

	63/B5	71/B5 71/B14	80/B5 80/B14	90S/B5 90S/B14	90L/B5 90L/B14	100L/B5 100L/B14	112M/B5 112M/B14
k	504.5	493.5	545.5	586.5	586.5	615	635.5
k1	565.5	584.5	638.5	690	690	723.5	740
n / n1	121 / 97	137 / 112	155 / 123	176 / 132	176 / 132	193 / 149	215 / 161
m1 (B5)	140	160	200	200	200	250	250
m1 (B14)	-	105	120	140	140	160	160
x	-	-	-	-	-	20,5	20,5

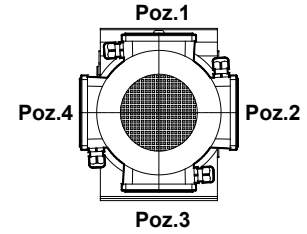

63-71-80-90-100-112
Tip / Type / Typ

Opsiyonel flanş ölçüleri için sayfa 587'ye bakınız.
Please see on page 587 for optional flange dimensions
Siehe Seite 587 für auswählbare Flanschabmessungen

KV273.03

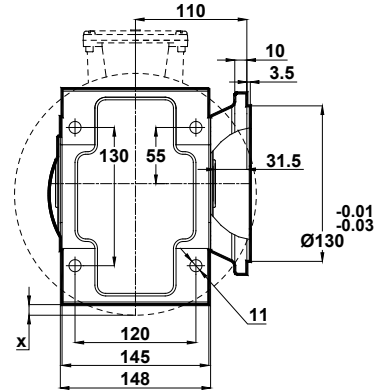
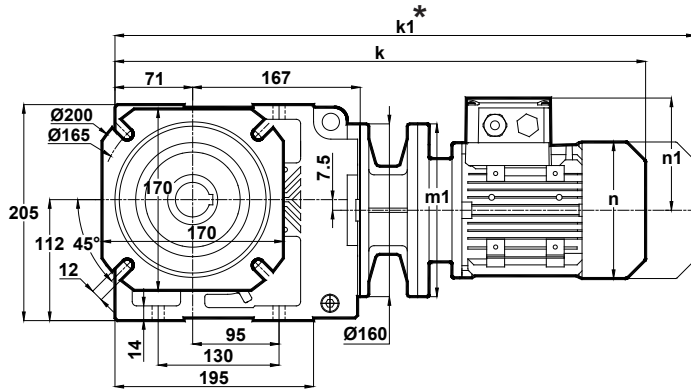

x: Motor Ayak bağlantı yüzeyinin altında ise
x: If Motor is lower than foot mounting plane
x: Wenn der Motor unter der Fußmontageebene ist

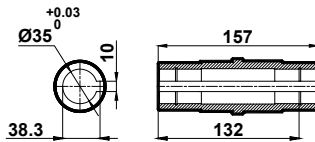

	63/B5	71/B5 71/B14	80/B5 80/B14	90S/B5 90S/B14	90L/B5 90L/B14	100L/B5 100L/B14	112M/B5 112M/B14
k	504.5	493.5	545.5	586.5	586.5	615	635.5
k1	565.5	584.5	638.5	690	690	723.5	740
n / n1	121 / 97	137 / 112	155 / 123	176 / 132	176 / 132	193 / 149	215 / 161
m1 (B5)	140	160	200	200	200	250	250
m1 (B14)	-	105	120	140	140	160	160
x	-	-	-	-	-	20,5	20,5

Opsiyonel flanş ölçüleri için sayfa 587'ye bakınız.
Please see on page 587 for optional flange dimensions
Siehe Seite 587 für auswählbare Flanschabmessungen

* " k1 " Ölçüsü frenli redüktörlere aittir.
Dimension " k1 " is for motors with brake.
Maße " k1 " ist für Bremsenmotoren.

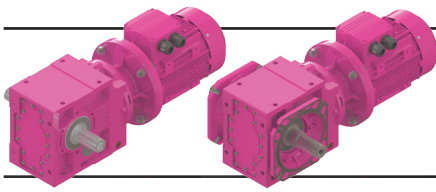

Ölçü Sayfaları

Dimension Pages

Abmessungsseiten

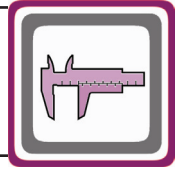

-Mil ucu çektirme deliği DIN 332 sayfa 2 / Tapped center hole to DIN 332, sheet 2 / Zentrierung mit Gewinde DIN 332, Blatt 2

KV273.04

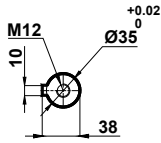
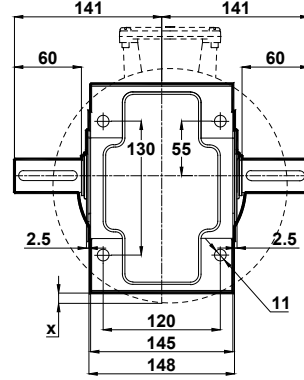
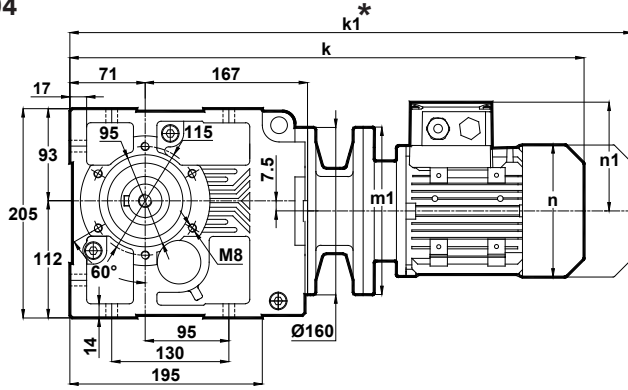

x: Motor Ayak bağlantı yüzeyinin altında ise
x: If Motor is lower than foot mounting plane
x: Wenn der Motor unter der Fußmontageebene ist

Klemens Pozisyonları
Terminal Box Positions
Klemmenkasten Positionen

	63/B5	71/B5 71/B14	80/B5 80/B14	90S/B5 90S/B14	90L/B5 90L/B14	100L/B5 100L/B14	112M/B5 112M/B14
k	504.5	493.5	545.5	586.5	586.5	615	635.5
k1	565.5	584.5	638.5	690	690	723.5	740
n / n1	121 / 97	137 / 112	155 / 123	176 / 132	176 / 132	193 / 149	215 / 161
m1 (B5)	140	160	200	200	200	250	250
m1 (B14)	-	105	120	140	140	160	160
x	-	-	-	-	-	20,5	20,5

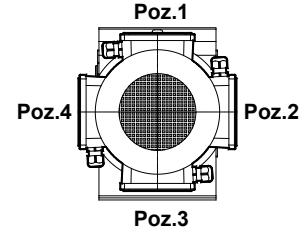

63-71-80-90-100-112
Tip / Type / Typ

KV273.05

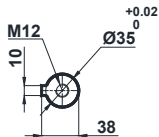
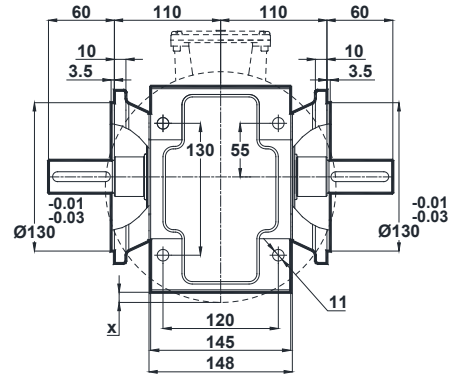
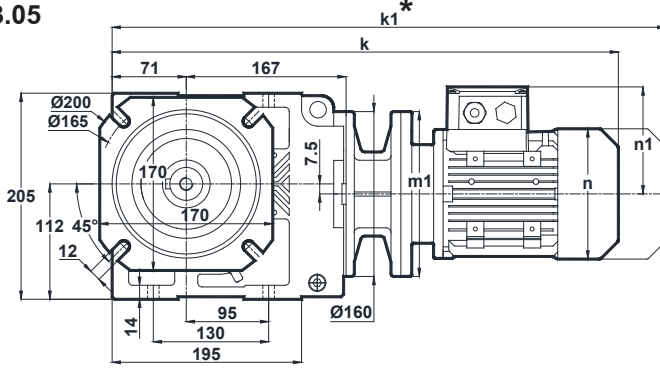

x: Motor Ayak bağlantı yüzeyinin altında ise
x: If Motor is lower than foot mounting plane
x: Wenn der Motor unter der Fußmontageebene ist

	63/B5	71/B5 71/B14	80/B5 80/B14	90S/B5 90S/B14	90L/B5 90L/B14	100L/B5 100L/B14	112M/B5 112M/B14
k	504.5	493.5	545.5	586.5	586.5	615	635.5
k1	565.5	584.5	638.5	690	690	723.5	740
n / n1	121 / 97	137 / 112	155 / 123	176 / 132	176 / 132	193 / 149	215 / 161
m1 (B5)	140	160	200	200	200	250	250
m1 (B14)	-	105	120	140	140	160	160
x	-	-	-	-	-	20,5	20,5

Opsiyonel flanş ölçüleri için sayfa 587'ye bakınız.
Please see on page 587 for optional flange dimensions
Siehe Seite 587 für auswählbare Flanschabmessungen

* " k1 " Ölçüsü frenli redüktörlere aittir.
Dimension " k1 " is for motors with brake.
Maße " k1 " ist für Bremsenmotoren.

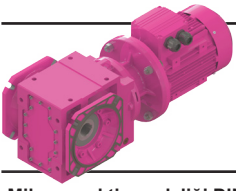

Ölçü Sayfaları Dimension Pages Abmessungsseiten

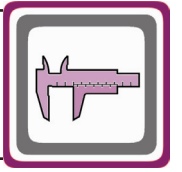

-Mil ucu çektirme deliği DIN 332 sayfa 2 / Tapped center hole to DIN 332, sheet 2 / Zentrierung mit Gewinde DIN 332, Blatt 2

KV273.08

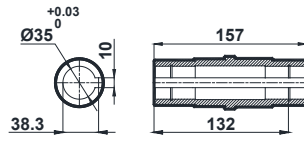
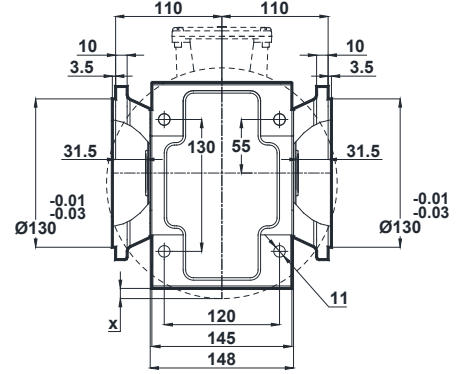
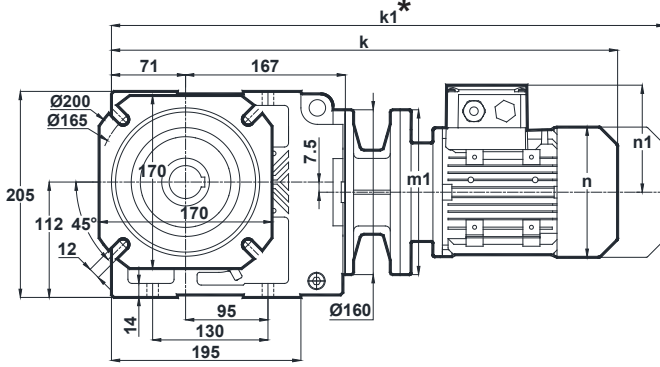

x: Motor ayak bağlantı yüzeyinin altında ise
x: If Motor is lower than foot mounting plane
x: Wenn der Motor unter der Fußmontageebene ist

Klemens Pozisyonları
Terminal Box Positions
Klemmenkasten Positionen

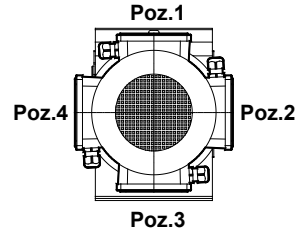

63-71-80-90-100-112
Tip / Type / Typ

Opsiyonel flanş ölçüleri için sayfa 587'ye bakınız.
Please see on page 587 for optional flange dimensions
Siehe Seite 587 für auswählbare Flanschabmessungen

	63/B5	71/B5 71/B14	80/B5 80/B14	90S/B5 90S/B14	90L/B5 90L/B14	100L/B5 100L/B14	112M/B5 112M/B14
k	504.5	493.5	545.5	586.5	586.5	615	635.5
k1	565.5	584.5	638.5	690	690	723.5	740
n / n1	121 / 97	137 / 112	155 / 123	176 / 132	176 / 132	193 / 149	215 / 161
m1 (B5)	140	160	200	200	200	250	250
m1 (B14)	-	105	120	140	140	160	160
x	-	-	-	-	-	20,5	20,5

* " k1 " Ölçüsü frenli redüktörlere aittir.
Dimension " k1 " is for motors with brake.
Maße " k1 " ist für Bremsenmotoren.

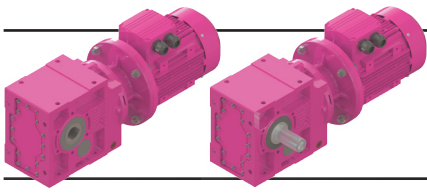

Ölçü Sayfaları

Dimension Pages

Abmessungsseiten

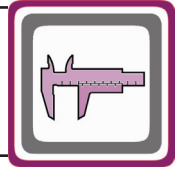

-Mil ucu çektirme deliği DIN 332 sayfa 2 / Tapped center hole to DIN 332, sheet 2 / Zentrierung mit Gewinde DIN 332, Blatt 2

KV275.00
KV276.00

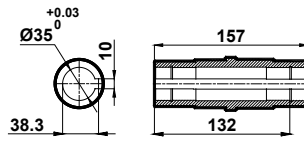
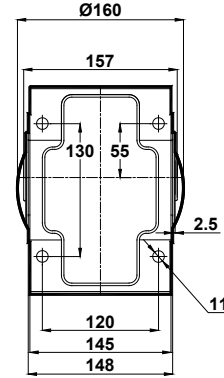
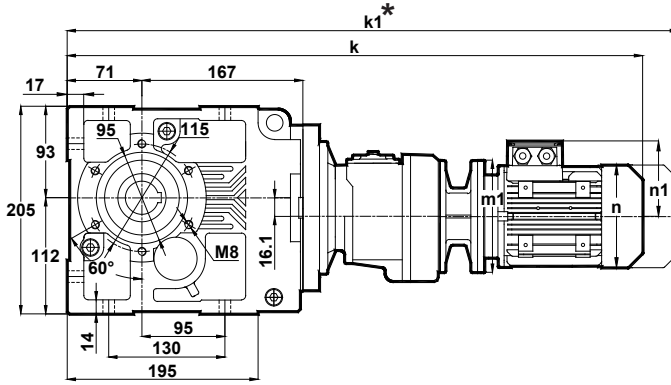

	63/B5 63/B14	71/B5 71/B14	80/B5 80/B14
k	620	639.5	677.5
k1	681	730.5	770.5
n / n1	121 / 97	137 / 112	155 / 123
m1 (B5)	140	160	200
m1 (B14)	90	105	120

Klemens Pozisyonları
Terminal Box Positions
Klemmenkasten Positionen

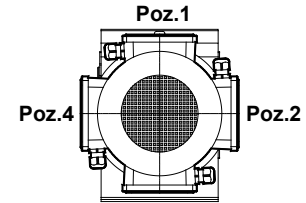

Poz.3
63-71-80
Tip / Type / Typ

KV275.01
KV276.01

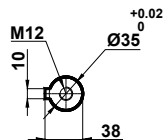
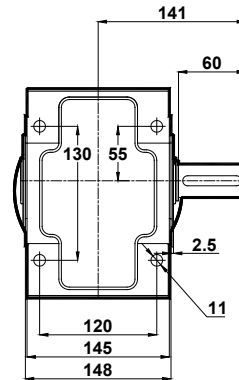
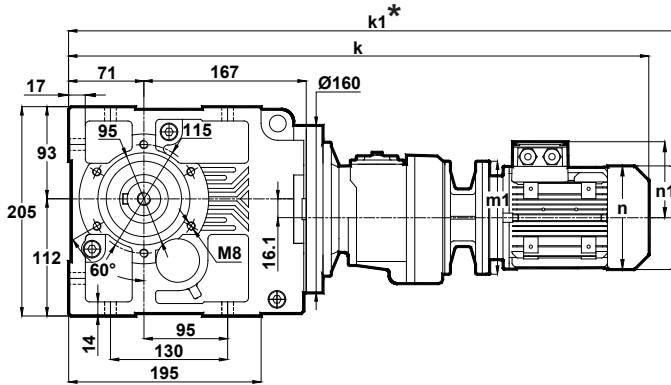

	63/B5 63/B14	71/B5 71/B14	80/B5 80/B14
k	620	639.5	677.5
k1	681	730.5	770.5
n / n1	121 / 97	137 / 112	155 / 123
m1 (B5)	140	160	200
m1 (B14)	90	105	120

* " k1 " Ölçüsü frenli redüktörlere aittir.
Dimension " k1 " is for motors with brake.
Maße " k1 " ist für Bremsenmotoren.

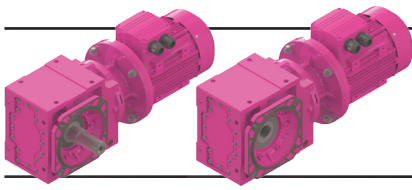

Ölçü Sayfaları

Dimension Pages

Abmessungsseiten



-Mil ucu çekirme deliği DIN 332 sayfa 2 / Tapped center hole to DIN 332, sheet 2 / Zentrierung mit Gewinde DIN 332, Blatt 2

KV275.02
KV276.02

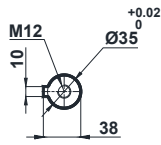
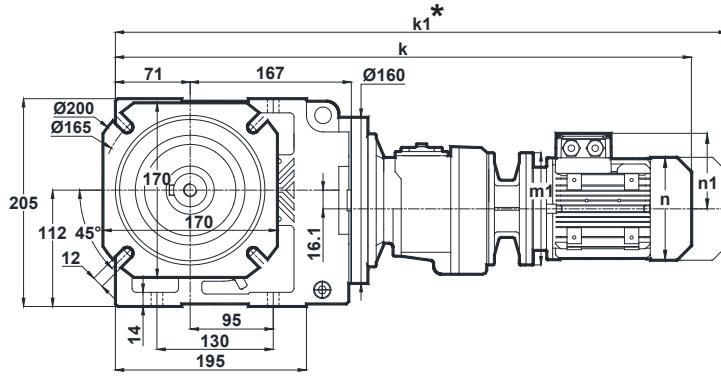

	63/B5 63/B14	71/B5 71/B14	80/B5 80/B14
k	620	639.5	677.5
k1	681	730.5	770.5
n / n1	121 / 97	137 / 112	155 / 123
m1 (B5)	140	160	200
m1 (B14)	90	105	120

Klemens Pozisyonları
Terminal Box Positions
Klemmenkasten Positionen

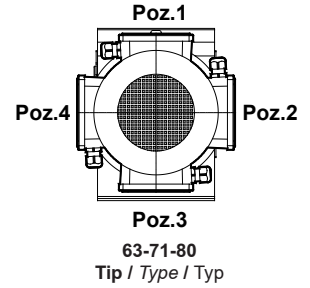

Opsiyonel flanş ölçüleri için sayfa 587'ye bakınız.
Please see on page 587 for optional flange dimensions
Siehe Seite 587 für auswählbare Flanschabmessungen

KV275.03
KV276.03

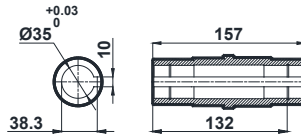
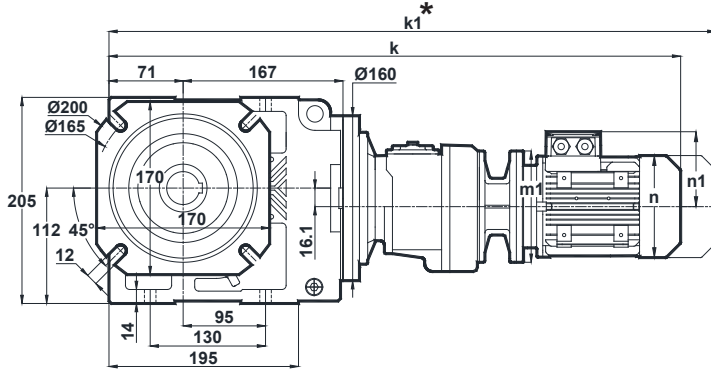

	63/B5 63/B14	71/B5 71/B14	80/B5 80/B14
k	620	639.5	677.5
k1	681	730.5	770.5
n / n1	121 / 97	137 / 112	155 / 123
m1 (B5)	140	160	200
m1 (B14)	90	105	120

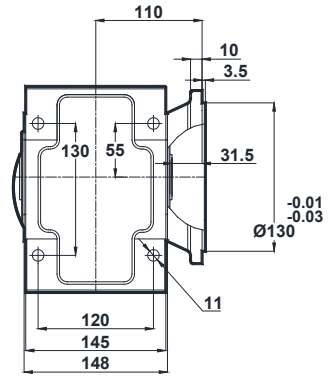

Opsiyonel flanş ölçüleri için sayfa 587'ye bakınız.
Please see on page 587 for optional flange dimensions
Siehe Seite 587 für auswählbare Flanschabmessungen

* " k1 " Ölçüsü frenli redüktörlere aittir.
Dimension " k1 " is for motors with brake.
Maße " k1 " ist für Bremsenmotoren.

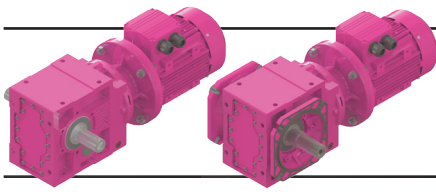

Ölçü Sayfaları

Dimension Pages

Abmessungsseiten

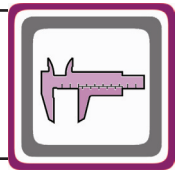

-Mil ucu çekirme deliği DIN 332 sayfa 2 / Tapped center hole to DIN 332, sheet 2 / Zentrierung mit Gewinde DIN 332, Blatt 2

KV275.04
KV276.04

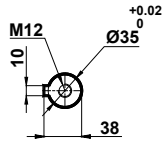
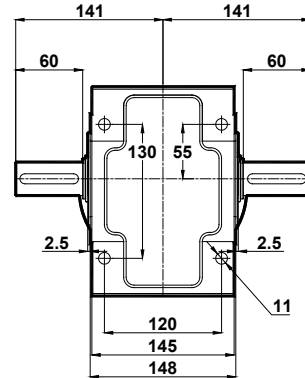
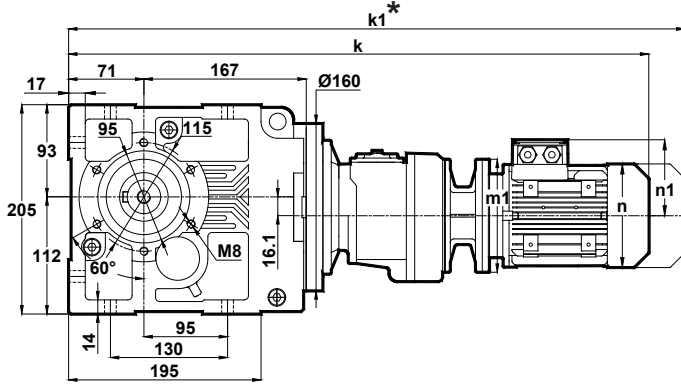

	63/B5 63/B14	71/B5 71/B14	80/B5 80/B14
k	620	639.5	677.5
k1	681	730.5	770.5
n / n1	121 / 97	137 / 112	155 / 123
m1 (B5)	140	160	200
m1 (B14)	90	105	120

Klemens Pozisyonları
Terminal Box Positions
Klemmenkasten Positionen

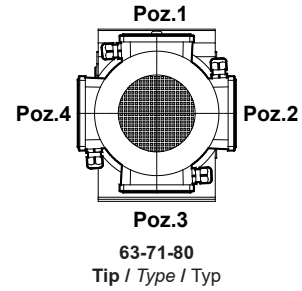

KV275.05
KV276.05

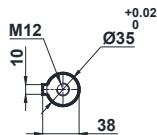
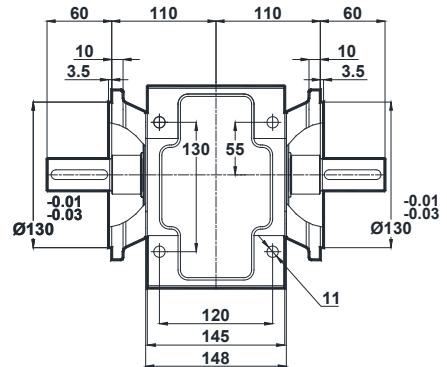
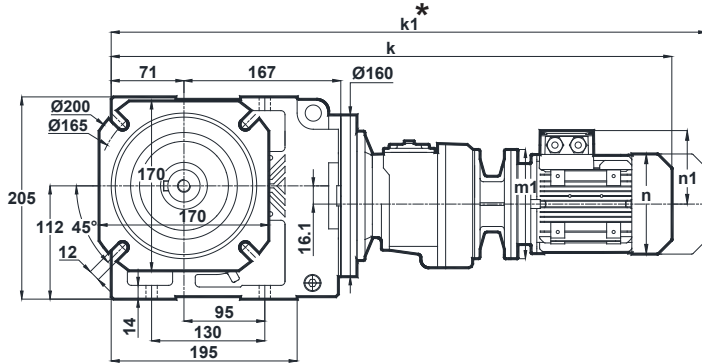

	63/B5 63/B14	71/B5 71/B14	80/B5 80/B14
k	620	639.5	677.5
k1	681	730.5	770.5
n / n1	121 / 97	137 / 112	155 / 123
m1 (B5)	140	160	200
m1 (B14)	90	105	120

Opsiyonel flanş ölçüleri için sayfa 587'ye bakınız.
Please see on page 587 for optional flange dimensions
Siehe Seite 587 für auswählbare Flanschabmessungen

* " k1 " Ölçüsü frenli redüktörlere aittir.
Dimension " k1 " is for motors with brake.
Maße " k1 " ist für Bremsenmotoren.

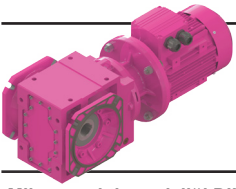

Ölçü Sayfaları Dimension Pages Abmessungsseiten



-Mil ucu çekirme deliği DIN 332 sayfa 2 / Tapped center hole to DIN 332, sheet 2 / Zentrierung mit Gewinde DIN 332, Blatt 2

KV275.08
KV276.08

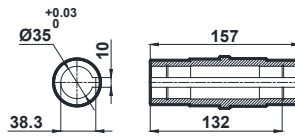
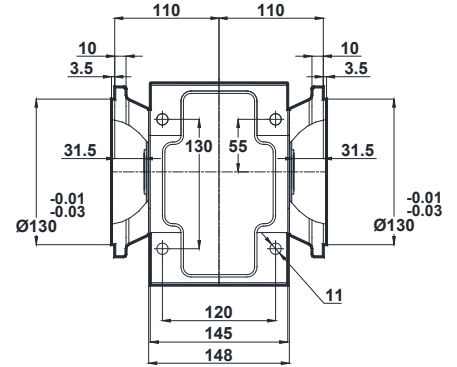
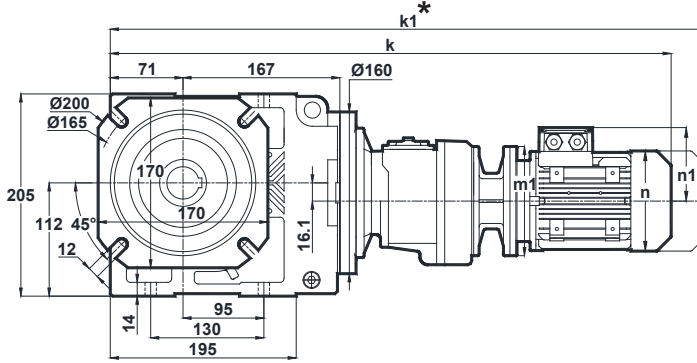

	63/B5 63/B14	71/B5 71/B14	80/B5 80/B14
k	620	639.5	677.5
k1	681	730.5	770.5
n / n1	121 / 97	137 / 112	155 / 123
m1 (B5)	140	160	200
m1 (B14)	90	105	120

Klemens Pozisyonları
Terminal Box Positions
Klemmenkasten Positionen

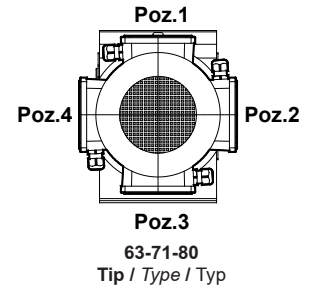

Opsiyonel flanş ölçüleri için sayfa 587'ye bakınız.
Please see on page 587 for optional flange dimensions
Siehe Seite 587 für auswählbare Flanschabmessungen

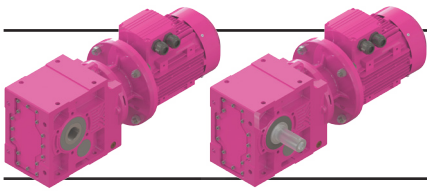

Ölçü Sayfaları

Dimension Pages

Abmessungsseiten

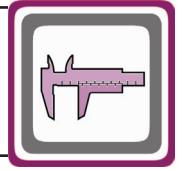

-Mil ucu çektirme deliği DIN 332 sayfa 2 / Tapped center hole to DIN 332, sheet 2 / Zentrierung mit Gewinde DIN 332, Blatt 2

KV283.00

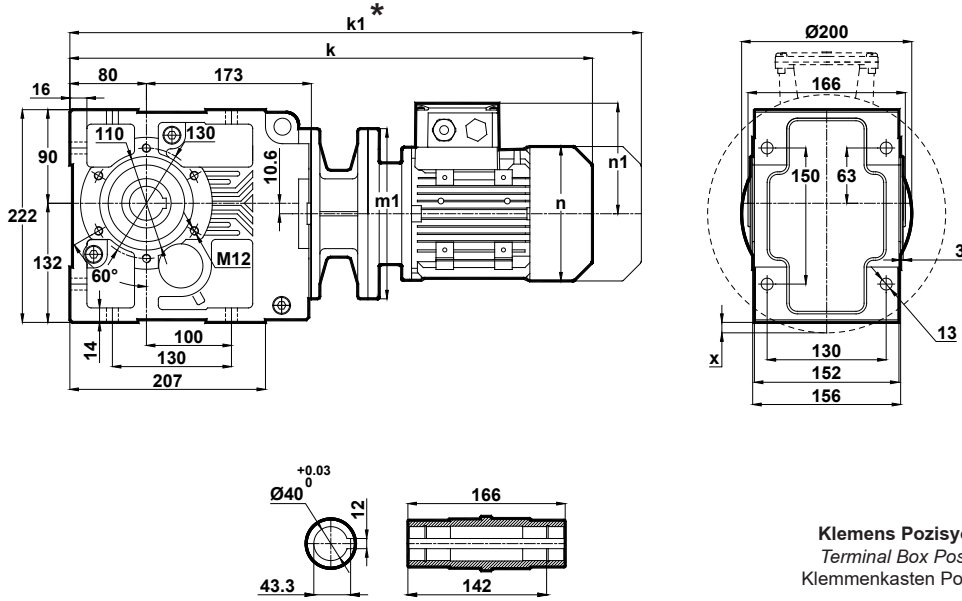

Klemens Pozisyonları
Terminal Box Positions
Klemmenkasten Positionen

	71/B5	80/B5 80/B14	90S/B5 90S/B14	90L/B5 90L/B14	100L/B5 100L/B14	112M/B5 112M/B14	132S/B5 132S/B14	132M/B5 132M/B14
k	530.5	553.5	594.5	594.5	647	667.5	771.5	771.5
k1	621.5	646.5	698	698	755.5	772	901.5	901.5
n / n1	137 / 112	155 / 123	176 / 132	176 / 132	193 / 149	215 / 161	257 / 181	257 / 181
m1 (B5)	160	200	200	200	250	250	300	300
m1 (B14)	-	120	140	140	160	160	200	200
x	-	-	-	-	3.6	3.6	28.6	28.6

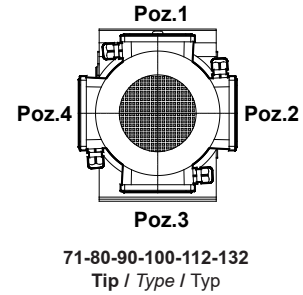

KV283.01

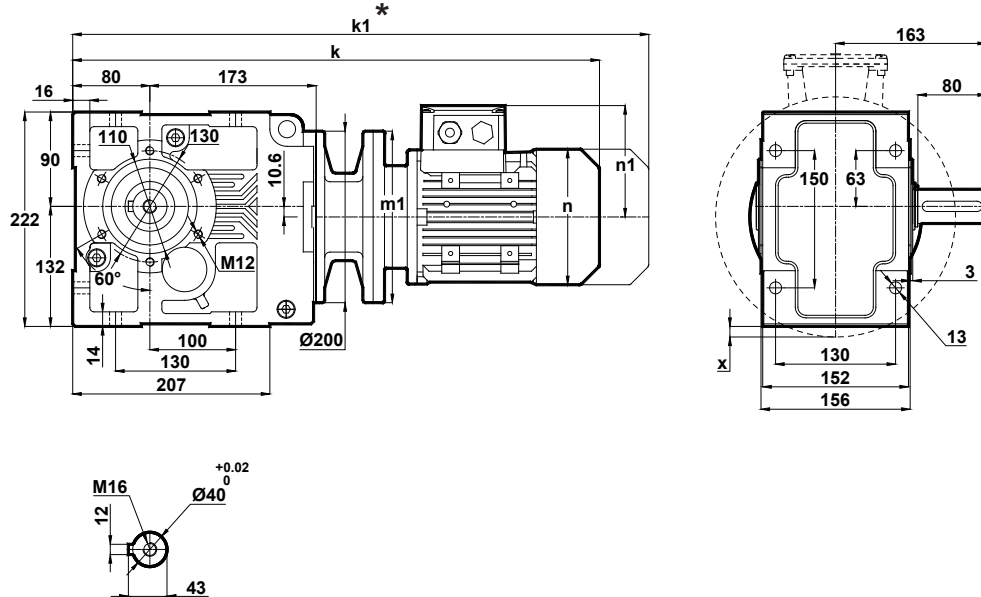

	71/B5	80/B5 80/B14	90S/B5 90S/B14	90L/B5 90L/B14	100L/B5 100L/B14	112M/B5 112M/B14	132S/B5 132S/B14	132M/B5 132M/B14
k	530.5	553.5	594.5	594.5	647	667.5	771.5	771.5
k1	621.5	646.5	698	698	755.5	772	901.5	901.5
n / n1	137 / 112	155 / 123	176 / 132	176 / 132	193 / 149	215 / 161	257 / 181	257 / 181
m1 (B5)	160	200	200	200	250	250	300	300
m1 (B14)	-	120	140	140	160	160	200	200
x	-	-	-	-	3.6	3.6	28.6	28.6

* " k1 " Ölçüsü frenli redüktörlere aittir.
Dimension " k1 " is for motors with brake.
Maße " k1 " ist für Bremsenmotoren.

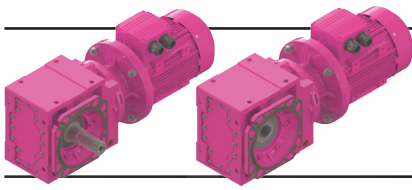

Ölçü Sayfaları

Dimension Pages

Abmessungsseiten

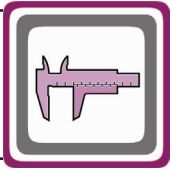

-Mil ucu çektirme deliği DIN 332 sayfa 2 / Tapped center hole to DIN 332, sheet 2 / Zentrierung mit Gewinde DIN 332, Blatt 2

KV283.02

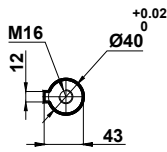
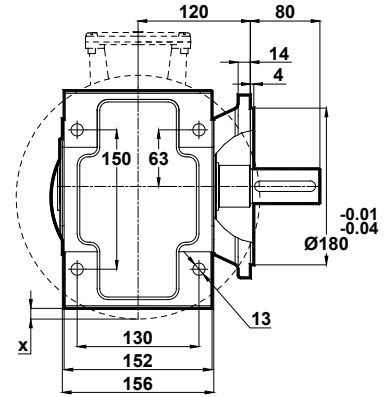
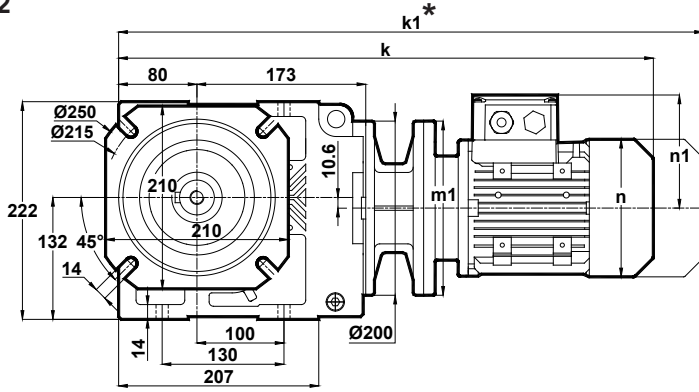

Klemens Pozisyonları
Terminal Box Positions
Klemmenkasten Positionen

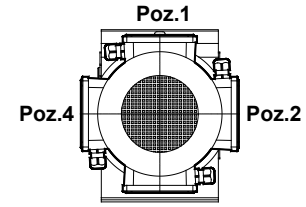

Poz.1
Poz.3
71-80-90-100-112-132
Tip / Type / Typ

Opsiyonel flanş ölçüleri için sayfa 587'ye bakınız.
Please see on page 587 for optional flange dimensions
Siehe Seite 587 für auswählbare Flanschabmessungen

	71/B5	80/B5 80/B14	90S/B5 90S/B14	90L/B5 90L/B14	100L/B5 100L/B14	112M/B5 112M/B14	132S/B5 132S/B14	132M/B5 132M/B14
k	530.5	553.5	594.5	594.5	647	667.5	771.5	771.5
k1	621.5	646.5	698	698	755.5	772	901.5	901.5
n / n1	137 / 112	155 / 123	176 / 132	176 / 132	193 / 149	215 / 161	257 / 181	257 / 181
m1 (B5)	160	200	200	200	250	250	300	300
m1 (B14)	-	120	140	140	160	160	200	200
x	-	-	-	-	3.6	3.6	28.6	28.6

KV283.03

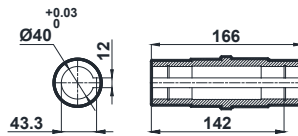
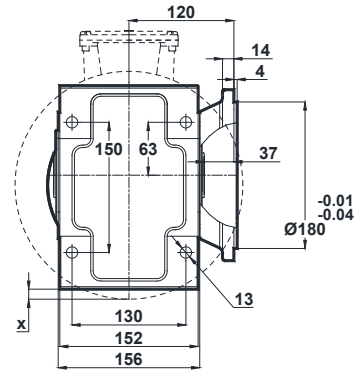
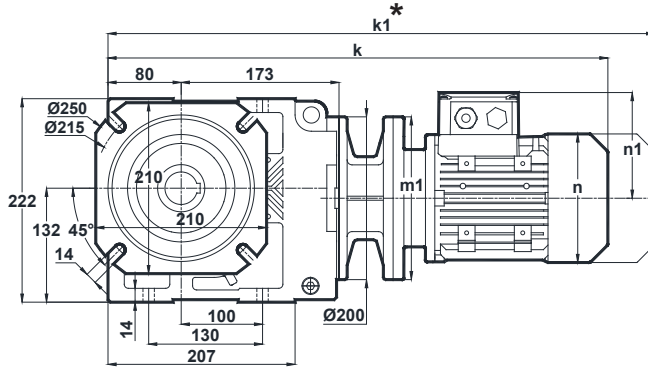

	71/B5	80/B5 80/B14	90S/B5 90S/B14	90L/B5 90L/B14	100L/B5 100L/B14	112M/B5 112M/B14	132S/B5 132S/B14	132M/B5 132M/B14
k	530.5	553.5	594.5	594.5	647	667.5	771.5	771.5
k1	621.5	646.5	698	698	755.5	772	901.5	901.5
n / n1	137 / 112	155 / 123	176 / 132	176 / 132	193 / 149	215 / 161	257 / 181	257 / 181
m1 (B5)	160	200	200	200	250	250	300	300
m1 (B14)	-	120	140	140	160	160	200	200
x	-	-	-	-	3.6	3.6	28.6	28.6

Opsiyonel flanş ölçüleri için sayfa 587'ye bakınız.
Please see on page 587 for optional flange dimensions
Siehe Seite 587 für auswählbare Flanschabmessungen

* " k1 " Ölçüsü frenli redüktörlere aittir.
Dimension " k1 " is for motors with brake.
Maße " k1 " ist für Bremsenmotoren.

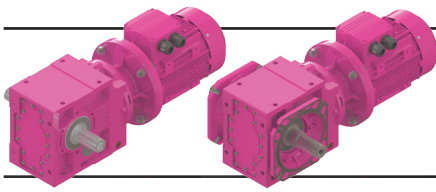

Ölçü Sayfaları

Dimension Pages

Abmessungsseiten

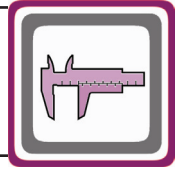

-Mil ucu çekirme deliği DIN 332 sayfa 2 / Tapped center hole to DIN 332, sheet 2 / Zentrierung mit Gewinde DIN 332, Blatt 2

KV283.04

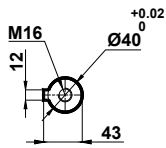
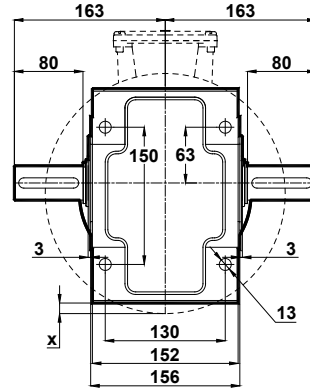
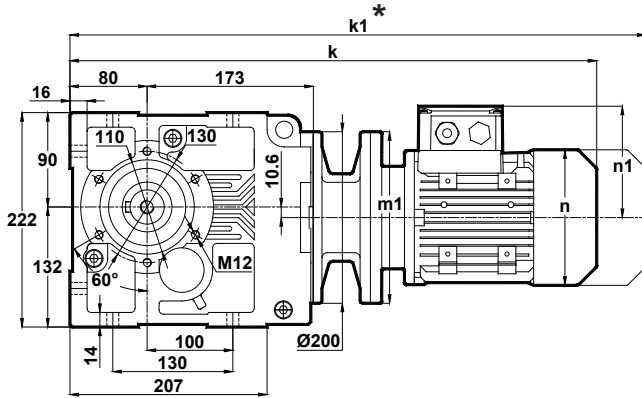

Klemens Pozisyonları
Terminal Box Positions
Klemmenkasten Positionen

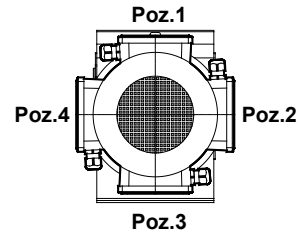

71-80-90-100-112-132
Tip / Type / Typ

	71/B5	80/B5 80/B14	90S/B5 90S/B14	90L/B5 90L/B14	100L/B5 100L/B14	112M/B5 112M/B14	132S/B5 132S/B14	132M/B5 132M/B14
k	530.5	553.5	594.5	594.5	647	667.5	771.5	771.5
k1	621.5	646.5	698	698	755.5	772	901.5	901.5
n / n1	137 / 112	155 / 123	176 / 132	176 / 132	193 / 149	215 / 161	257 / 181	257 / 181
m1 (B5)	160	200	200	200	250	250	300	300
m1 (B14)	-	120	140	140	160	160	200	200
x	-	-	-	-	3.6	3.6	28.6	28.6

KV283.05

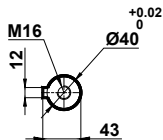
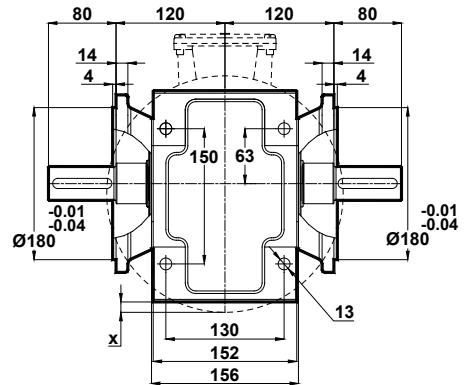
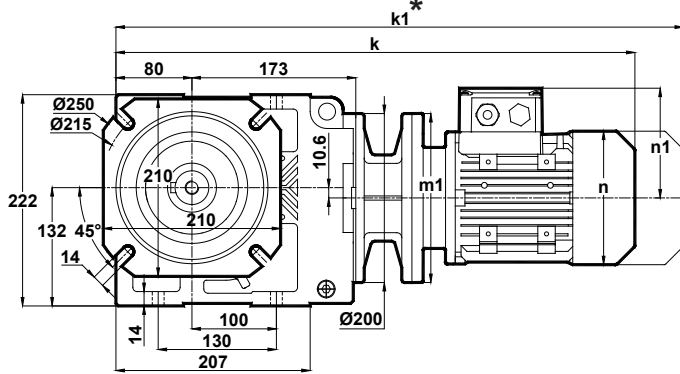

Opsiyonel flanş ölçüleri için sayfa 587'ye bakınız.
Please see on page 587 for optional flange dimensions
Siehe Seite 587 für auswählbare Flanschabmessungen

	71/B5	80/B5 80/B14	90S/B5 90S/B14	90L/B5 90L/B14	100L/B5 100L/B14	112M/B5 112M/B14	132S/B5 132S/B14	132M/B5 132M/B14
k	530.5	553.5	594.5	594.5	647	667.5	771.5	771.5
k1	621.5	646.5	698	698	755.5	772	901.5	901.5
n / n1	137 / 112	155 / 123	176 / 132	176 / 132	193 / 149	215 / 161	257 / 181	257 / 181
m1 (B5)	160	200	200	200	250	250	300	300
m1 (B14)	-	120	140	140	160	160	200	200
x	-	-	-	-	3.6	3.6	28.6	28.6

* "k1" Ölçüsü frenli redüktörlere aittir.
Dimension "k1" is for motors with brake.
Maße "k1" ist für Bremsenmotoren.

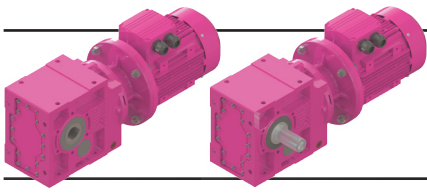

Ölçü Sayfaları

Dimension Pages

Abmessungsseiten

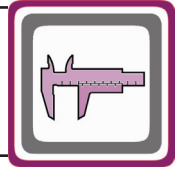

-Mil ucu çekirme deliği DIN 332 sayfa 2 / Tapped center hole to DIN 332, sheet 2 / Zentrierung mit Gewinde DIN 332, Blatt 2

KV284.00

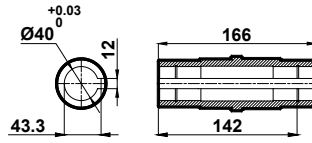
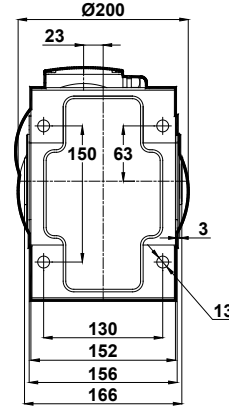
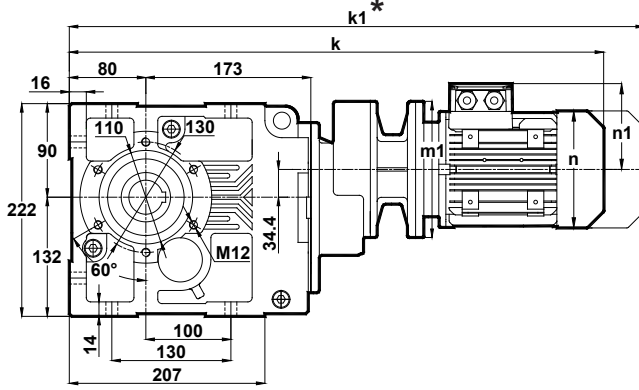

Klemens Pozisyonları
Terminal Box Positions
Klemmenkasten Positionen

	63/B5	71/B5 71/B14	80/B5 80/B14
k	589.5	578.5	630.5
k1	650.5	669.5	723.5
n / n1	121 / 97	137 / 112	155 / 123
m1 (B5)	140	160	200
m1 (B14)	-	105	120

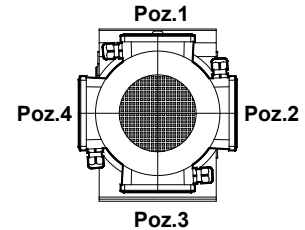

71-80-90-100-112
Tip / Type / Typ

KV284.01

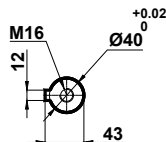
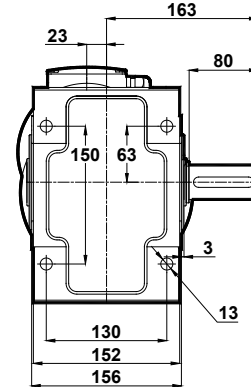
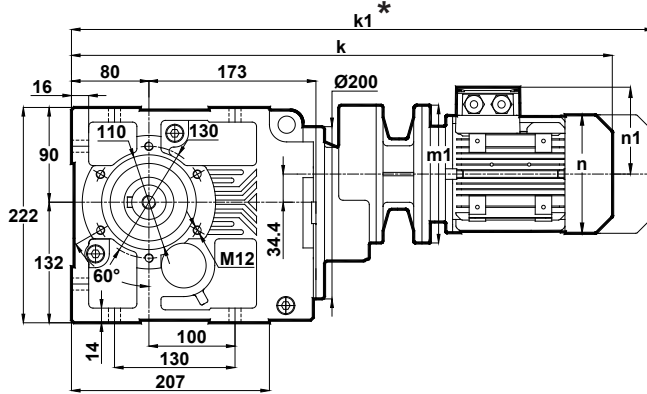

	63/B5	71/B5 71/B14	80/B5 80/B14
k	589.5	578.5	630.5
k1	650.5	669.5	723.5
n / n1	121 / 97	137 / 112	155 / 123
m1 (B5)	140	160	200
m1 (B14)	-	105	120

* " k1 " Ölçüsü frenli redüktörlere aittir.
Dimension " k1 " is for motors with brake.
Maße " k1 " ist für Bremsenmotoren.

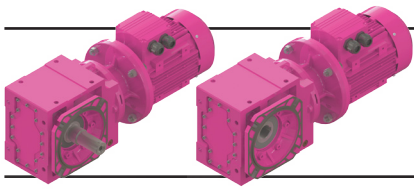

Ölçü Sayfaları

Dimension Pages

Abmessungsseiten



-Mil ucu çektirme deliği DIN 332 sayfa 2 / Tapped center hole to DIN 332, sheet 2 / Zentrierung mit Gewinde DIN 332, Blatt 2

KV284.02

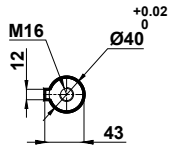
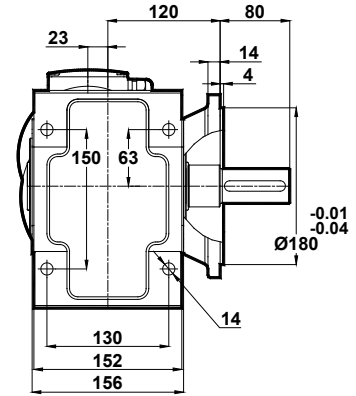
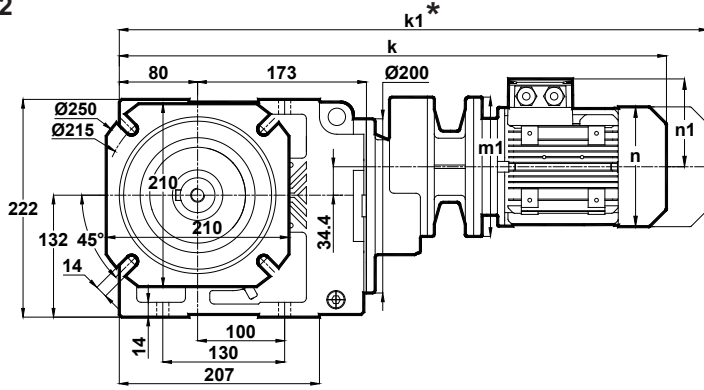

Klemens Pozisyonları
Terminal Box Positions
Klemmenkasten Positionen

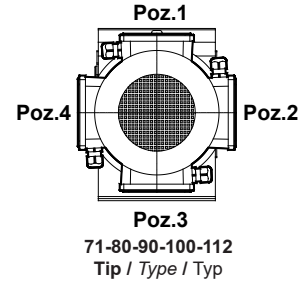

	63/B5	71/B5 71/B14	80/B5 80/B14
k	589.5	578.5	630.5
k1	650.5	669.5	723.5
n / n1	121 / 97	137 / 112	155 / 123
m1 (B5)	140	160	200
m1 (B14)	-	105	120

Opsiyonel flanş ölçüleri için sayfa 587'ye bakınız.
Please see on page 587 for optional flange dimensions
Siehe Seite 587 für auswählbare Flanschabmessungen

KV284.03

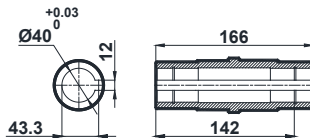
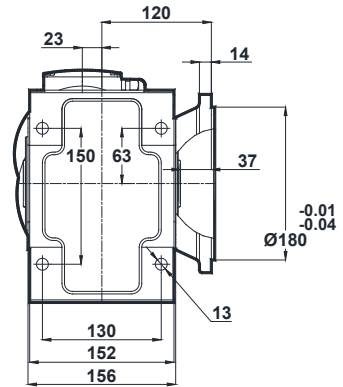
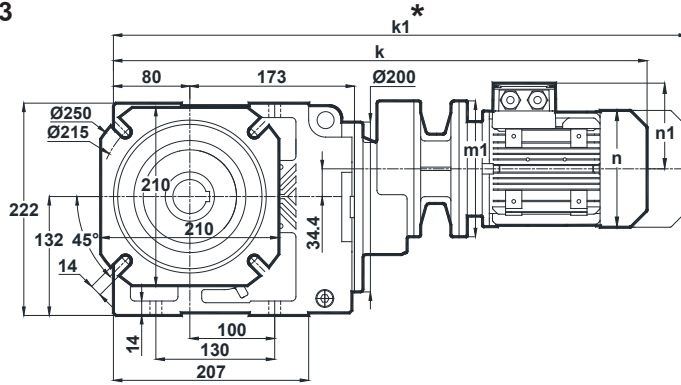

	63/B5	71/B5 71/B14	80/B5 80/B14
k	589.5	578.5	630.5
k1	650.5	669.5	723.5
n / n1	121 / 97	137 / 112	155 / 123
m1 (B5)	140	160	200
m1 (B14)	-	105	120

Opsiyonel flanş ölçüleri için sayfa 587'ye bakınız.
Please see on page 587 for optional flange dimensions
Siehe Seite 587 für auswählbare Flanschabmessungen

* " k1 " Ölçüsü frenli redüktörlere aittir.
Dimension " k1 " is for motors with brake.
Maße " k1 " ist für Bremsenmotoren.

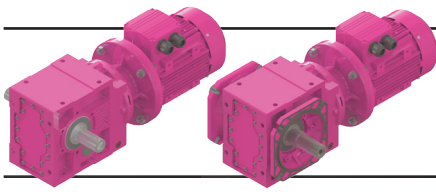

Ölçü Sayfaları

Dimension Pages

Abmessungsseiten

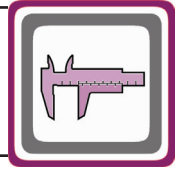

-Mil ucu çektirme deliği DIN 332 sayfa 2 / Tapped center hole to DIN 332, sheet 2 / Zentrierung mit Gewinde DIN 332, Blatt 2

KV284.04

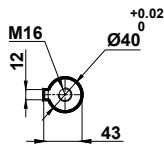
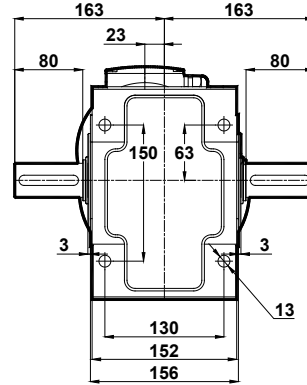
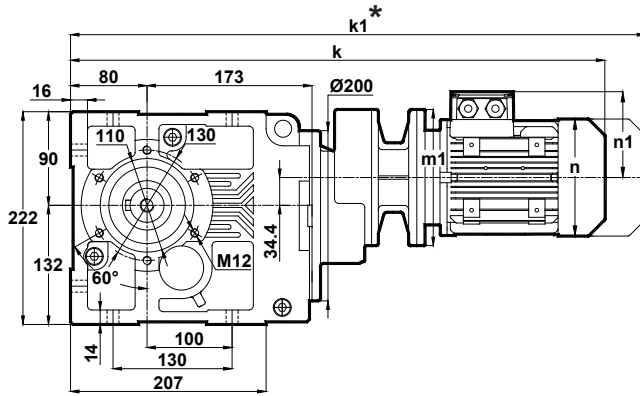

	63/B5	71/B5 71/B14	80/B5 80/B14
k	589.5	578.5	630.5
k1	650.5	669.5	723.5
n / n1	121 / 97	137 / 112	155 / 123
m1 (B5)	140	160	200
m1 (B14)	-	105	120

Klemens Pozisyonları
Terminal Box Positions
Klemmenkasten Positionen

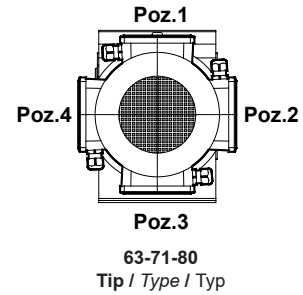

KV284.05

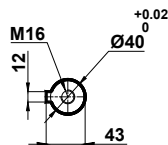
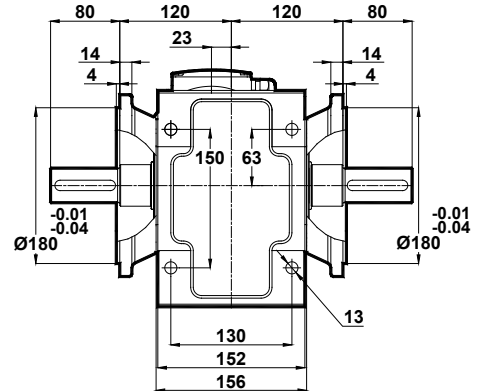
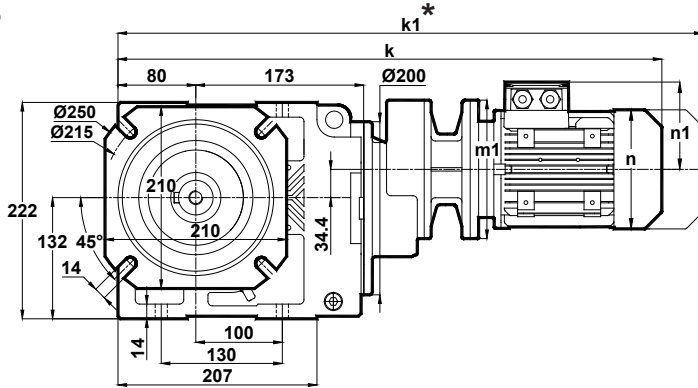

	63/B5	71/B5 71/B14	80/B5 80/B14
k	589.5	578.5	630.5
k1	650.5	669.5	723.5
n / n1	121 / 97	137 / 112	155 / 123
m1 (B5)	140	160	200
m1 (B14)	-	105	120

Opsiyonel flanş ölçüleri için sayfa 587'ye bakınız.
Please see on page 587 for optional flange dimensions
Siehe Seite 587 für auswählbare Flanschabmessungen

* " k1 " Ölçüsü frenli redüktörlere aittir.
Dimension " k1 " is for motors with brake.
Maße " k1 " ist für Bremsenmotoren.

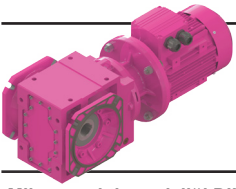

Ölçü Sayfaları Dimension Pages Abmessungsseiten



-Mil ucu çektirme deliği DIN 332 sayfa 2 / Tapped center hole to DIN 332, sheet 2 / Zentrierung mit Gewinde DIN 332, Blatt 2

KV284.08

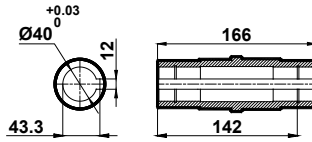
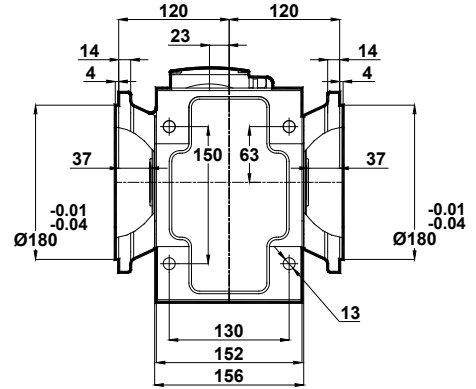
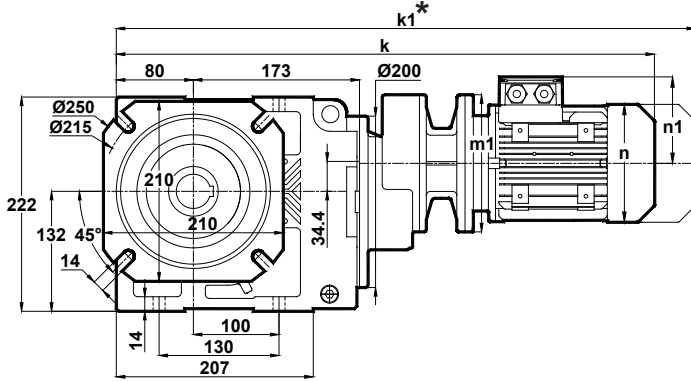

	63/B5	71/B5 71/B14	80/B5 80/B14
k	589.5	578.5	630.5
k1	650.5	669.5	723.5
n / n1	121 / 97	137 / 112	155 / 123
m1 (B5)	140	160	200
m1 (B14)	-	105	120

Klemens Pozisyonları
Terminal Box Positions
Klemmenkasten Positionen

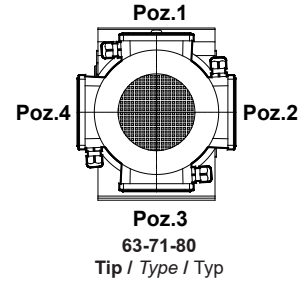

Opsiyonel flanş ölçüleri için sayfa 587'ye bakınız.
Please see on page 587 for optional flange dimensions
Siehe Seite 587 für auswählbare Flanschabmessungen

* " k1 " Ölçüsü frenli redüktörlere aittir.
Dimension " k1 " is for motors with brake.
Maße " k1 " ist für Bremsenmotoren.

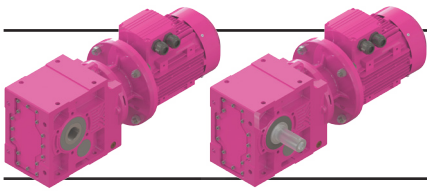

Ölçü Sayfaları Dimension Pages Abmessungenseiten

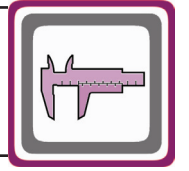

-Mil ucu çektirme deliği DIN 332 sayfa 2 / Tapped center hole to DIN 332, sheet 2 / Zentrierung mit Gewinde DIN 332, Blatt 2

KV285.00
KV286.00

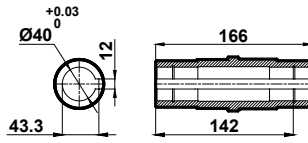
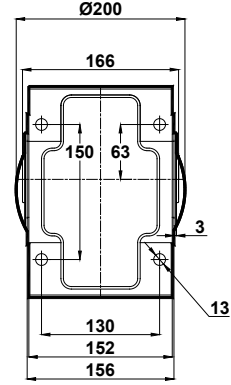
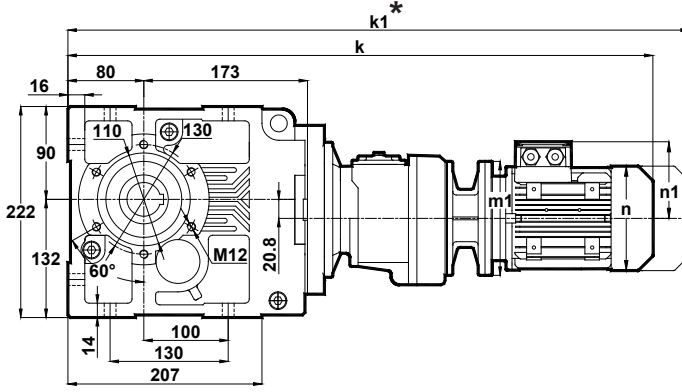

Klemens Pozisyonları
Terminal Box Positions
Klemmenkasten Positionen

	63/B5
k	742
k1	803
n / n1	121 / 97
m1 (B5)	140
m1 (B14)	-

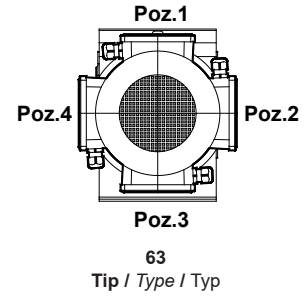

KV285.01
KV286.01

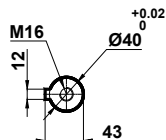
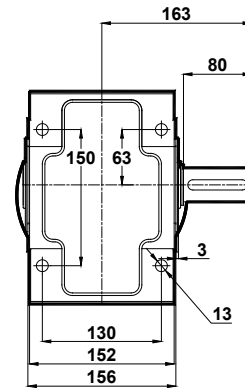
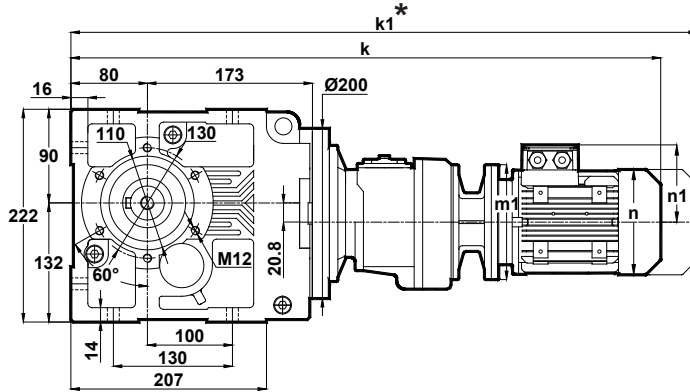

	63/B5
k	742
k1	803
n / n1	121 / 97
m1 (B5)	140
m1 (B14)	-

* " k1 " Ölçüsü frenli redüktörlere aittir.
Dimension " k1 " is for motors with brake.
Maße " k1 " ist für Bremsenmotoren.

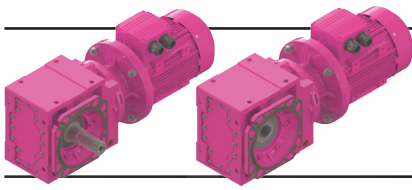

Ölçü Sayfaları

Dimension Pages

Abmessungsseiten

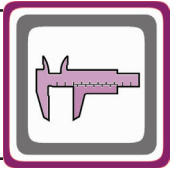

-Mil ucu çektirme deliği DIN 332 sayfa 2 / Tapped center hole to DIN 332, sheet 2 / Zentrierung mit Gewinde DIN 332, Blatt 2

KV285.02
KV286.02

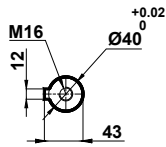
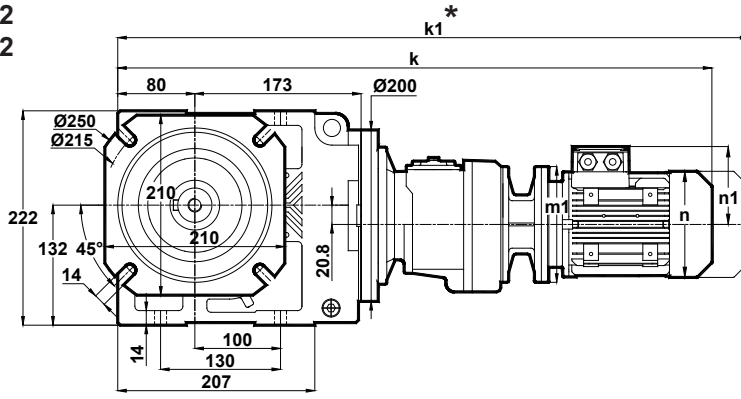

	63/B5
k	742
k1	803
n / n1	121 / 97
m1 (B5)	140
m1 (B14)	-

Klemens Pozisyonları
Terminal Box Positions
Klemmenkasten Positionen

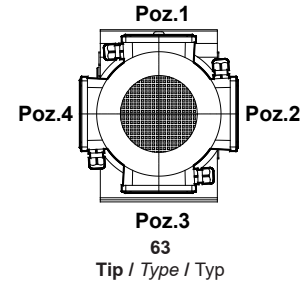

Tip / Type / Typ

Opsiyonel flanş ölçüleri için sayfa 587'ye bakınız.
Please see on page 587 for optional flange dimensions
Siehe Seite 587 für auswählbare Flanschabmessungen

KV285.03
KV286.03

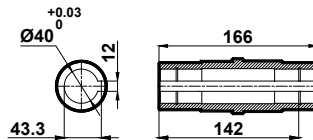
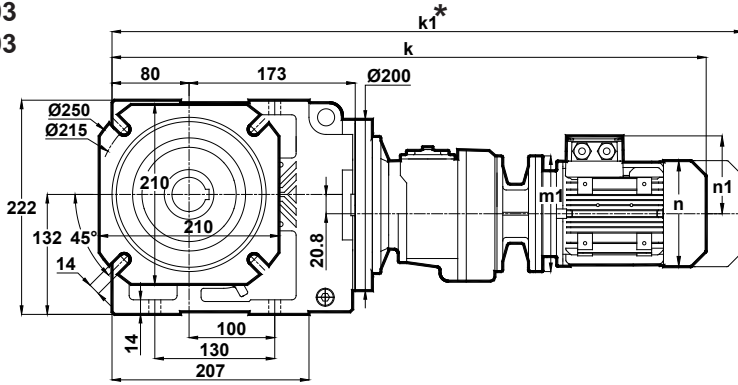

	63/B5
k	742
k1	803
n / n1	121 / 97
m1 (B5)	140
m1 (B14)	-

Opsiyonel flanş ölçüleri için sayfa 587'ye bakınız.
Please see on page 587 for optional flange dimensions
Siehe Seite 587 für auswählbare Flanschabmessungen

* " k1 " Ölçüsü frenli redüktörlere aittir.
Dimension " k1 " is for motors with brake.
Maße " k1 " ist für Bremsenmotoren.

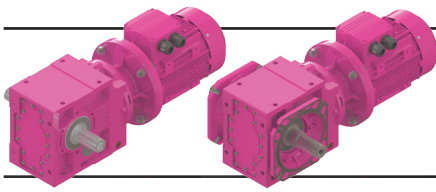

Ölçü Sayfaları Dimension Pages Abmessungsseiten

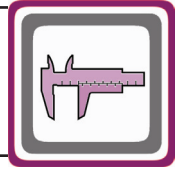

-Mil ucu çektirme deliği DIN 332 sayfa 2 / Tapped center hole to DIN 332, sheet 2 / Zentrierung mit Gewinde DIN 332, Blatt 2

KV285.04
KV286.04

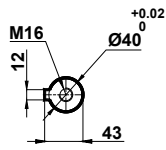
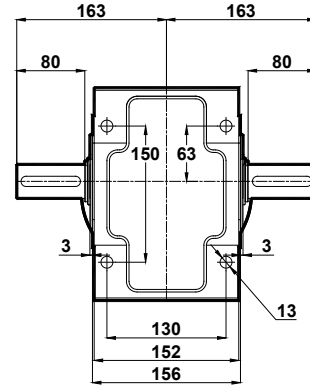
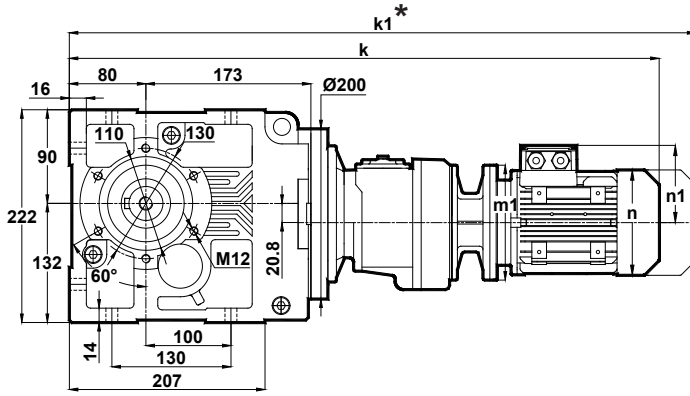

	63/B5
k	742
k1	803
n / n1	121 / 97
m1 (B5)	140
m1 (B14)	-

Klemens Pozisyonları
Terminal Box Positions
Klemmenkasten Positionen

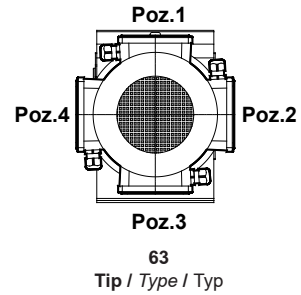

KV285.05
KV286.05

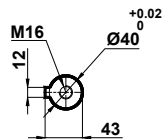
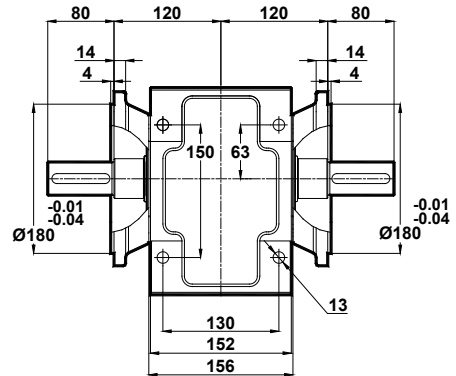
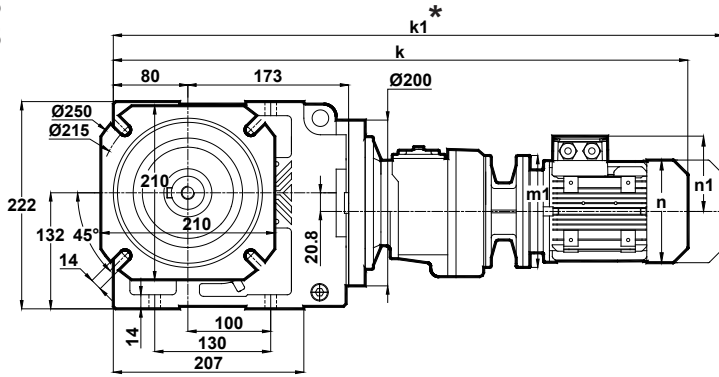

	63/B5
k	742
k1	803
n / n1	121 / 97
m1 (B5)	140
m1 (B14)	-

Opsiyonel flanş ölçüleri için sayfa 587'ye bakınız.
Please see on page 587 for optional flange dimensions
Siehe Seite 587 für auswählbare Flanschabmessungen

* " k1 " Ölçüsü frenli redüktörlere aittir.
Dimension " k1 " is for motors with brake.
Maße " k1 " ist für Bremsenmotoren.

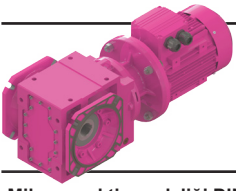

Ölçü Sayfaları Dimension Pages Abmessungsseiten

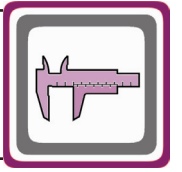

-Mil ucu çektirme deliği DIN 332 sayfa 2 / Tapped center hole to DIN 332, sheet 2 / Zentrierung mit Gewinde DIN 332, Blatt 2

KV285.08
KV286.08

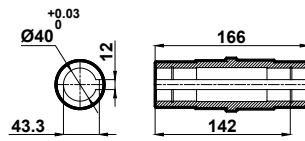
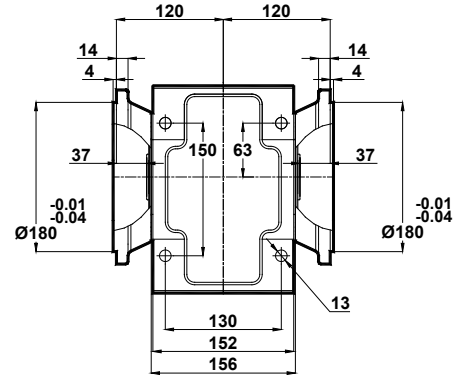
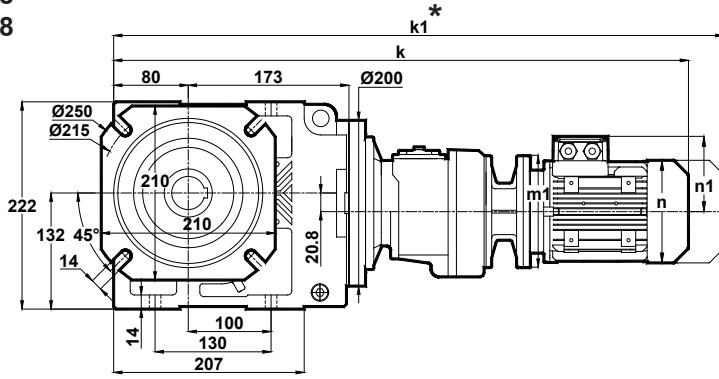

	63/B5
k	742
k1	803
n / n1	121 / 97
m1 (B5)	140
m1 (B14)	-

Klemens Pozisyonları
Terminal Box Positions
Klemmenkasten Positionen

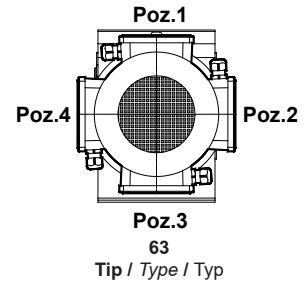

Opsiyonel flanş ölçüleri için sayfa 587'ye bakınız.
Please see on page 587 for optional flange dimensions
Siehe Seite 587 für auswählbare Flanschabmessungen

* " k1 " Ölçüsü frenli redüktörlere aittir.
Dimension " k1 " is for motors with brake.
Maße " k1 " ist für Bremsenmotoren.

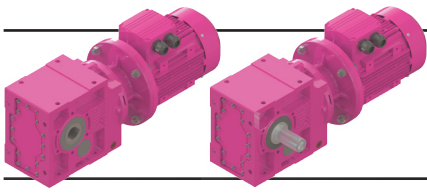

Ölçü Sayfaları

Dimension Pages

Abmessungsseiten

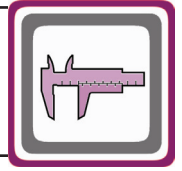

-Mil ucu çektirme deliği DIN 332 sayfa 2 / Tapped center hole to DIN 332, sheet 2 / Zentrierung mit Gewinde DIN 332, Blatt 2

KV373.00

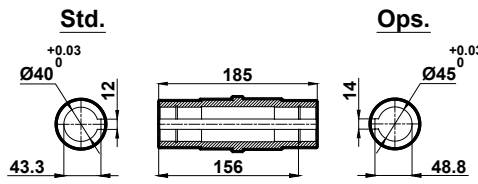
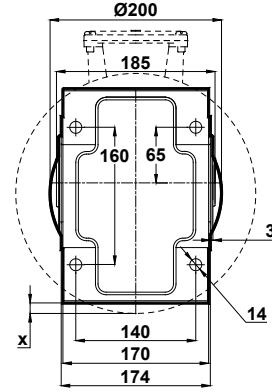
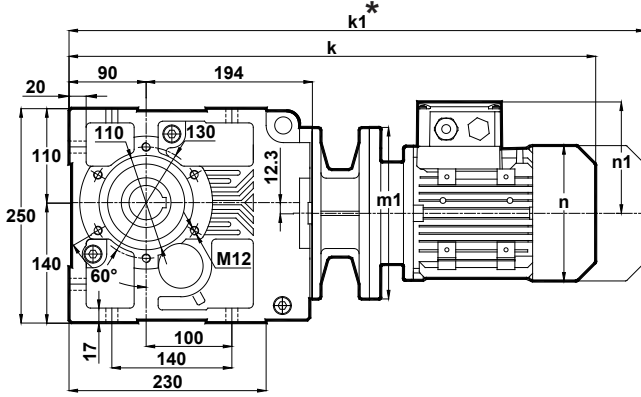

x: Motor Ayak bağlantı yüzeyinin altında ise
x: If Motor is lower than foot mounting plane
x: Wenn der Motor unter der Fußmontageebene ist

Klemens Pozisyonları
Terminal Box Positions
Klemmenkasten Positionen

	71/B5	80/B5 80/B14	90S/B5 90S/B14	90L/B5 90L/B14	100L/B5 100L/B14	112M/B5 112M/B14	132S/B5 132S/B14	132M/B5 132M/B14
k	561.5	584.5	625.5	625.5	678	698.5	802.5	802.5
k1	652.5	677.5	729	729	786.5	803	932.5	932.5
n / n1	137 / 112	155 / 123	176 / 132	176 / 132	193 / 149	215 / 161	257 / 181	257 / 181
m1 (B5)	160	200	200	200	250	250	300	300
m1 (B14)	-	120	140	140	160	160	200	200
x	-	-	-	-	-	-	22,3	22,3

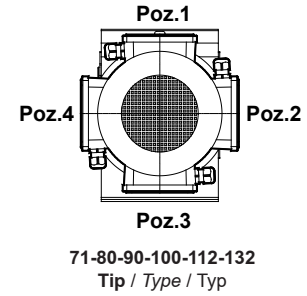

KV373.01

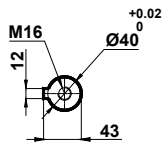
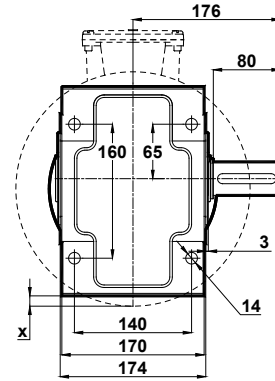
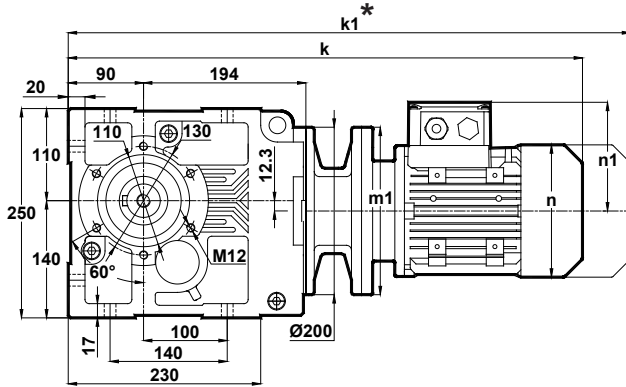

x: Motor Ayak bağlantı yüzeyinin altında ise
x: If Motor is lower than foot mounting plane
x: Wenn der Motor unter der Fußmontageebene ist

	71/B5	80/B5 80/B14	90S/B5 90S/B14	90L/B5 90L/B14	100L/B5 100L/B14	112M/B5 112M/B14	132S/B5 132S/B14	132M/B5 132M/B14
k	561.5	584.5	625.5	625.5	678	698.5	802.5	802.5
k1	652.5	677.5	729	729	786.5	803	932.5	932.5
n / n1	137 / 112	155 / 123	176 / 132	176 / 132	193 / 149	215 / 161	257 / 181	257 / 181
m1 (B5)	160	200	200	200	250	250	300	300
m1 (B14)	-	120	140	140	160	160	200	200
x	-	-	-	-	-	-	22,3	22,3

* " k1 " Ölçüsü frenli redüktörlere aittir.
Dimension " k1 " is for motors with brake.
Maße " k1 " ist für Bremsenmotoren.

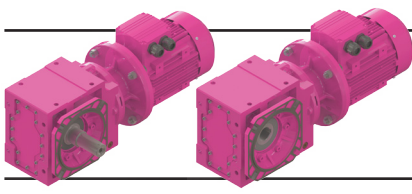

Ölçü Sayfaları Dimension Pages Abmessungsseiten



-Mil ucu çektirme deliği DIN 332 sayfa 2 / Tapped center hole to DIN 332, sheet 2 / Zentrierung mit Gewinde DIN 332, Blatt 2

KV373.02
KV373.02

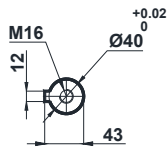
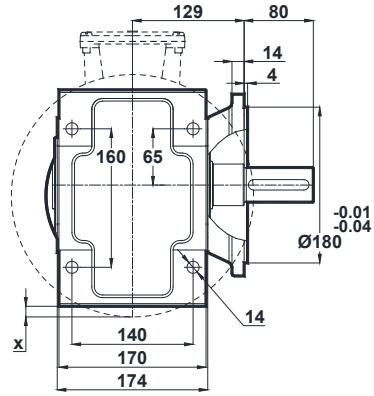
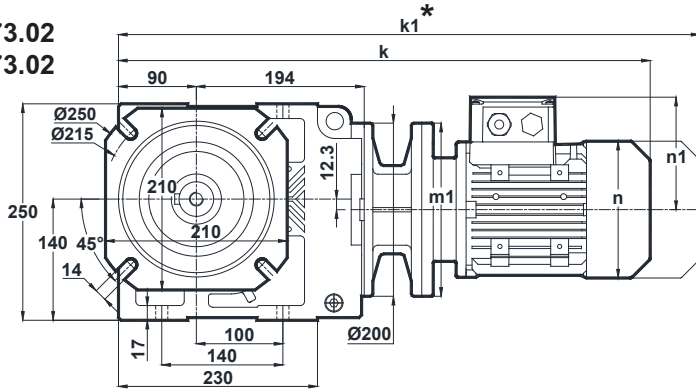

x: Motor Ayak bağlantı yüzeyinin altında ise
x: If Motor is lower than foot mounting plane
x: Wenn der Motor unter der Fußmontageebene ist

Klemens Pozisyonları
Terminal Box Positions
Klemmenkasten Positionen

Poz.1

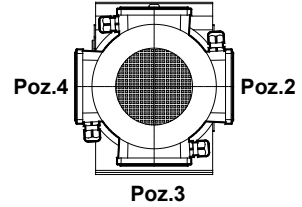

Poz.3

71-80-90-100-112-132

Tip / Type / Typ

Opsiyonel flanş ölçüleri için sayfa 587'ye bakınız.
Please see on page 587 for optional flange dimensions
Siehe Seite 587 für auswählbare Flanschabmessungen

	71/B5	80/B5 80/B14	90S/B5 90S/B14	90L/B5 90L/B14	100L/B5 100L/B14	112M/B5 112M/B14	132S/B5 132S/B14	132M/B5 132M/B14
k	561.5	584.5	625.5	625.5	678	698.5	802.5	802.5
k1	652.5	677.5	729	729	786.5	803	932.5	932.5
n / n1	137 / 112	155 / 123	176 / 132	176 / 132	193 / 149	215 / 161	257 / 181	257 / 181
m1 (B5)	160	200	200	200	250	250	300	300
m1 (B14)	-	120	140	140	160	160	200	200
x	-	-	-	-	-	-	22,3	22,3

KV373.03

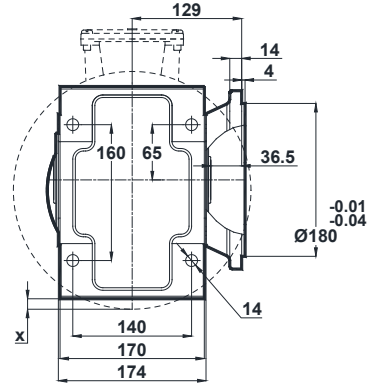
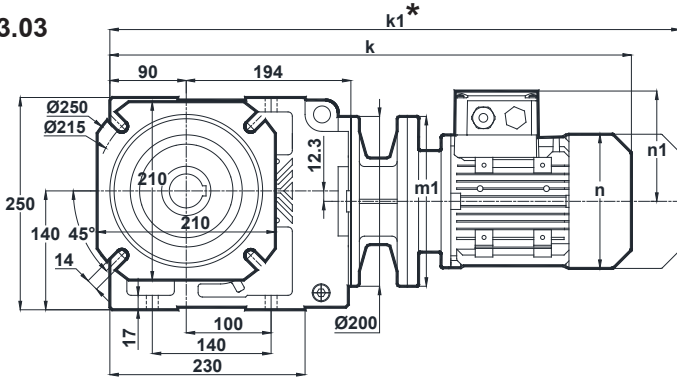

Std.

Ops.

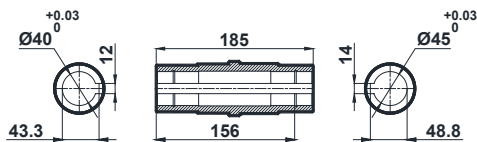

x: Motor Ayak bağlantı yüzeyinin altında ise
x: If Motor is lower than foot mounting plane
x: Wenn der Motor unter der Fußmontageebene ist

	71/B5	80/B5 80/B14	90S/B5 90S/B14	90L/B5 90L/B14	100L/B5 100L/B14	112M/B5 112M/B14	132S/B5 132S/B14	132M/B5 132M/B14
k	561.5	584.5	625.5	625.5	678	698.5	802.5	802.5
k1	652.5	677.5	729	729	786.5	803	932.5	932.5
n / n1	137 / 112	155 / 123	176 / 132	176 / 132	193 / 149	215 / 161	257 / 181	257 / 181
m1 (B5)	160	200	200	200	250	250	300	300
m1 (B14)	-	120	140	140	160	160	200	200
x	-	-	-	-	-	-	22,3	22,3

Opsiyonel flanş ölçüleri için sayfa 587'ye bakınız.
Please see on page 587 for optional flange dimensions
Siehe Seite 587 für auswählbare Flanschabmessungen

* " k1 " Ölçüsü frenli redüktörlere aittir.
Dimension " k1 " is for motors with brake.
Maße " k1 " ist für Bremsenmotoren.

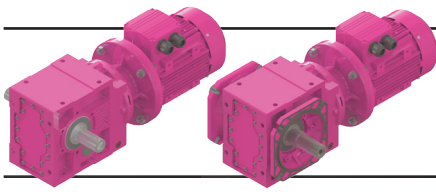

Ölçü Sayfaları

Dimension Pages

Abmessungsseiten

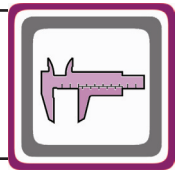

-Mil ucu çektirme deliği DIN 332 sayfa 2 / Tapped center hole to DIN 332, sheet 2 / Zentrierung mit Gewinde DIN 332, Blatt 2

KV373.04
KV373.04

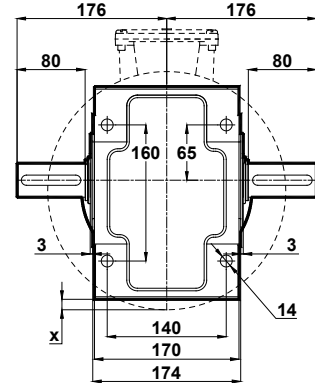
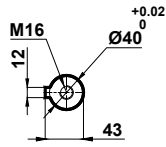
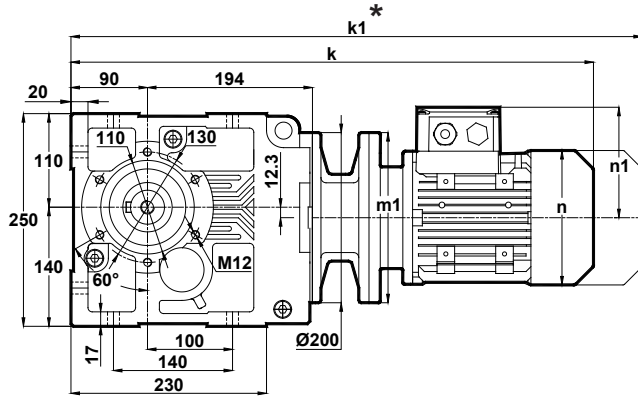

x: Motor Ayak bağlantı yüzeyinin altında ise
x: If Motor is lower than foot mounting plane
x: Wenn der Motor unter der Fußmontageebene ist

Klemens Pozisyonları
Terminal Box Positions
Klemmenkasten Positionen

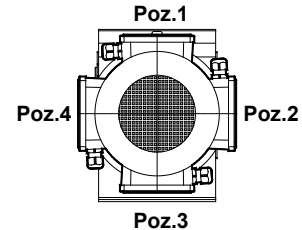

71-80-90-100-112-132
Tip / Type / Typ

	71/B5	80/B5 80/B14	90S/B5 90S/B14	90L/B5 90L/B14	100L/B5 100L/B14	112M/B5 112M/B14	132S/B5 132S/B14	132M/B5 132M/B14
k	561.5	584.5	625.5	625.5	678	698.5	802.5	802.5
k1	652.5	677.5	729	729	786.5	803	932.5	932.5
n / n1	137 / 112	155 / 123	176 / 132	176 / 132	193 / 149	215 / 161	257 / 181	257 / 181
m1 (B5)	160	200	200	200	250	250	300	300
m1 (B14)	-	120	140	140	160	160	200	200
x	-	-	-	-	-	-	22,3	22,3

KV373.05
KV373.05

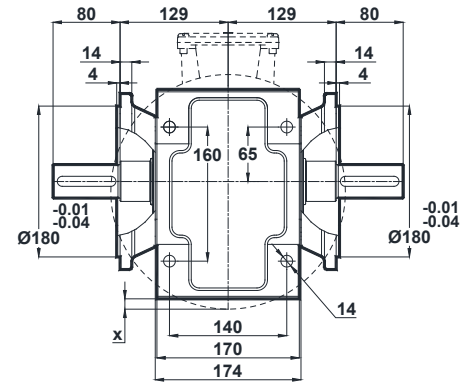
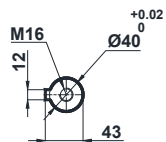
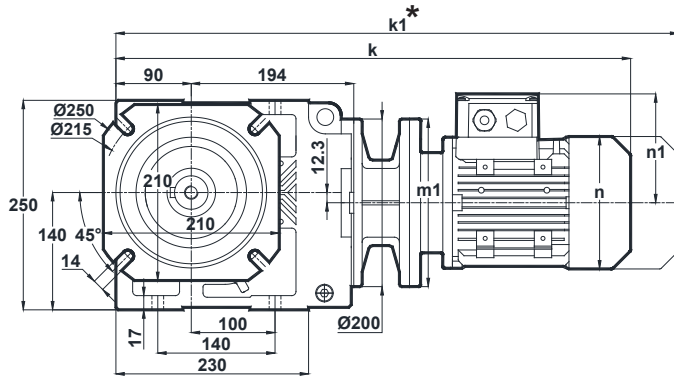

x: Motor Ayak bağlantı yüzeyinin altında ise
x: If Motor is lower than foot mounting plane
x: Wenn der Motor unter der Fußmontageebene ist

Opsiyonel flanş ölçüleri için sayfa 587'ye bakınız.
Please see on page 587 for optional flange dimensions
Siehe Seite 587 für auswählbare Flanschabmessungen

	71/B5	80/B5 80/B14	90S/B5 90S/B14	90L/B5 90L/B14	100L/B5 100L/B14	112M/B5 112M/B14	132S/B5 132S/B14	132M/B5 132M/B14
k	561.5	584.5	625.5	625.5	678	698.5	802.5	802.5
k1	652.5	677.5	729	729	786.5	803	932.5	932.5
n / n1	137 / 112	155 / 123	176 / 132	176 / 132	193 / 149	215 / 161	257 / 181	257 / 181
m1 (B5)	160	200	200	200	250	250	300	300
m1 (B14)	-	120	140	140	160	160	200	200
x	-	-	-	-	-	-	22,3	22,3

* "k1" Ölçüsü frenli redüktörlere aittir.
Dimension "k1" is for motors with brake.
Maße "k1" ist für Bremsenmotoren.

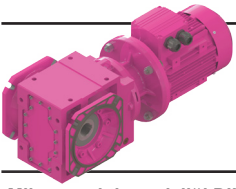

Ölçü Sayfaları Dimension Pages Abmessungsseiten



-Mil ucu çekirme deliği DIN 332 sayfa 2 / Tapped center hole to DIN 332, sheet 2 / Zentrierung mit Gewinde DIN 332, Blatt 2

KV373.08
KV373.08

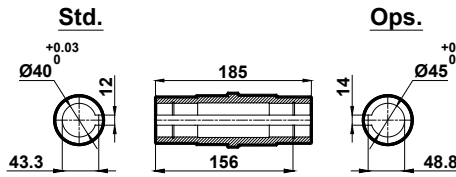
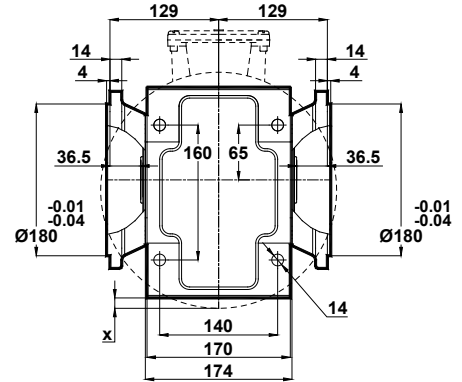
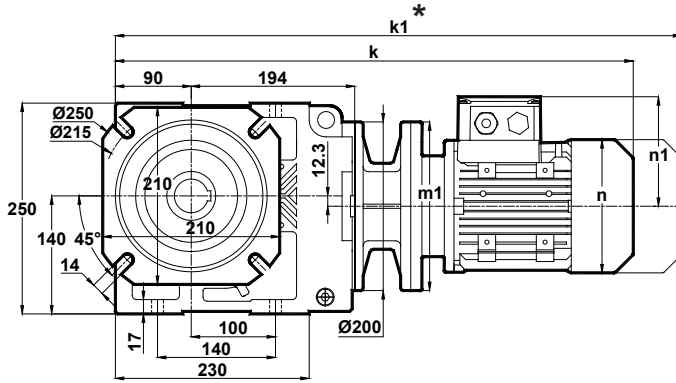

x: Motor Ayak bağlantı yüzeyinin altında ise
x: If Motor is lower than foot mounting plane
x: Wenn der Motor unter der Fußmontageebene ist

Klemens Pozisyonları
Terminal Box Positions
Klemmenkasten Positionen

	71/B5	80/B5 80/B14	90S/B5 90S/B14	90L/B5 90L/B14	100L/B5 100L/B14	112M/B5 112M/B14	132S/B5 132S/B14	132M/B5 132M/B14
k	561.5	584.5	625.5	625.5	678	698.5	802.5	802.5
k1	652.5	677.5	729	729	786.5	803	932.5	932.5
n / n1	137 / 112	155 / 123	176 / 132	176 / 132	193 / 149	215 / 161	257 / 181	257 / 181
m1 (B5)	160	200	200	200	250	250	300	300
m1 (B14)	-	120	140	140	160	160	200	200
x	-	-	-	-	-	-	22,3	22,3

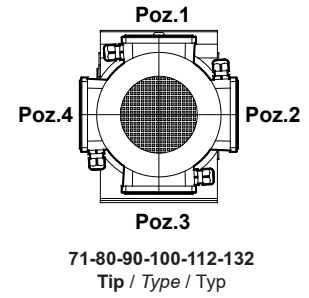

Opsiyonel flanş ölçüleri için sayfa 587'ye bakınız.
Please see on page 587 for optional flange dimensions
Siehe Seite 587 für auswählbare Flanschabmessungen

* " k1 " Ölçüsü frenli redüktörlere aittir.
Dimension " k1 " is for motors with brake.
Maße " k1 " ist für Bremsenmotoren.

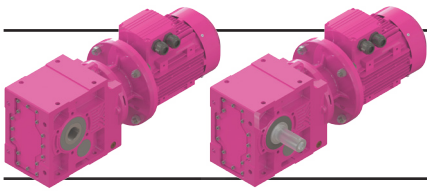

Ölçü Sayfaları

Dimension Pages

Abmessungsseiten

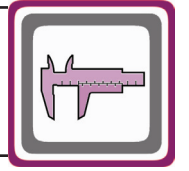

-Mil ucu çektirme deliği DIN 332 sayfa 2 / Tapped center hole to DIN 332, sheet 2 / Zentrierung mit Gewinde DIN 332, Blatt 2

KV374.00

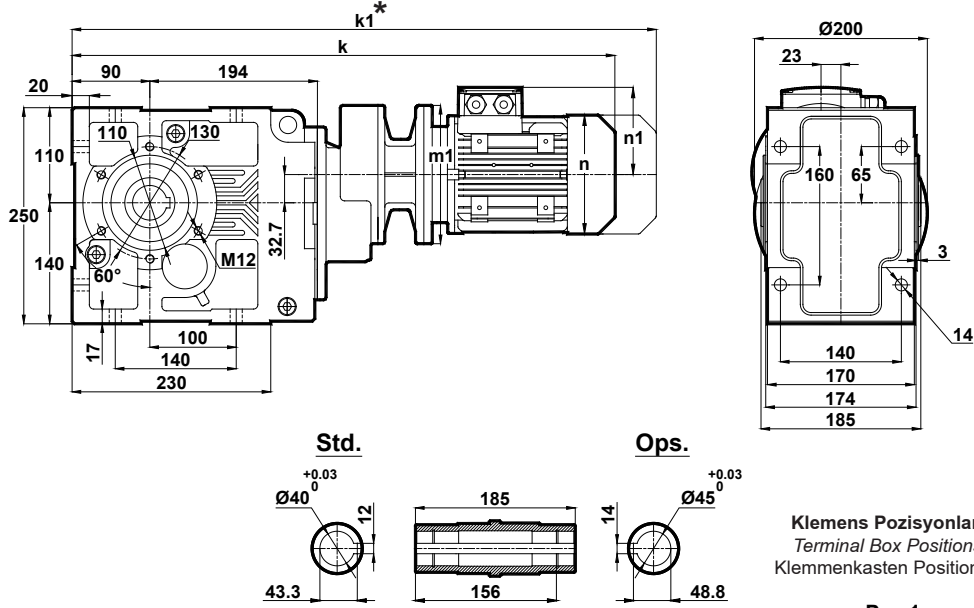

Klemens Pozisyonları
Terminal Box Positions
Klemmenkasten Positionen

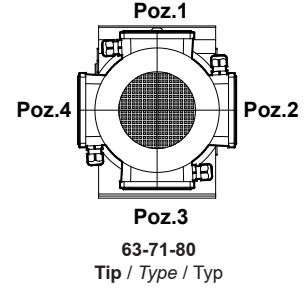

	63/B5	71/B5 71/B14	80/B5 80/B14
k	620.5	609.5	661.5
k1	681.5	700.5	754.5
n / n1	121 / 97	137 / 121	155 / 123
m1 (B5)	140	160	200
m1 (B14)	-	105	120

KV374.01

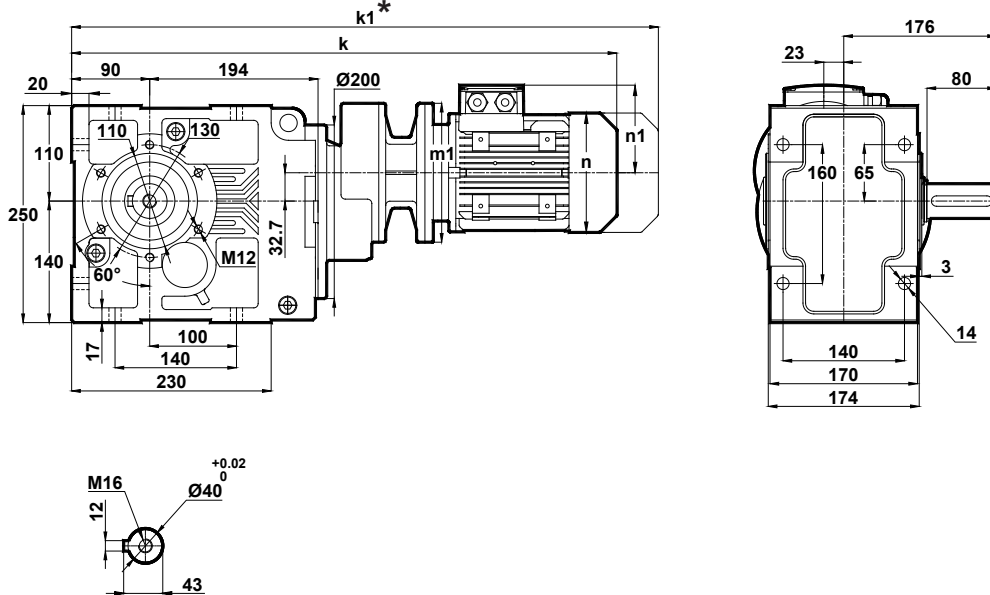

	63/B5	71/B5 71/B14	80/B5 80/B14
k	620.5	609.5	661.5
k1	681.5	700.5	754.5
n / n1	121 / 97	137 / 121	155 / 123
m1 (B5)	140	160	200
m1 (B14)	-	105	120

* " k1 " Ölçüsü frenli redüktörlere aittir.
Dimension " k1 " is for motors with brake.
Maße " k1 " ist für Bremsenmotoren.

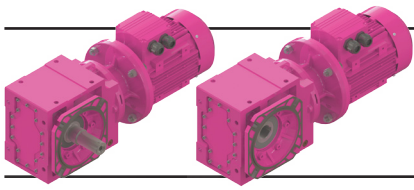

Ölçü Sayfaları

Dimension Pages

Abmessungsseiten

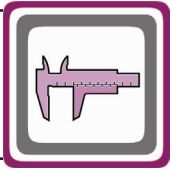

-Mil ucu çektirme deliği DIN 332 sayfa 2 / Tapped center hole to DIN 332, sheet 2 / Zentrierung mit Gewinde DIN 332, Blatt 2

KV374.02

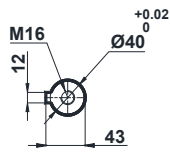
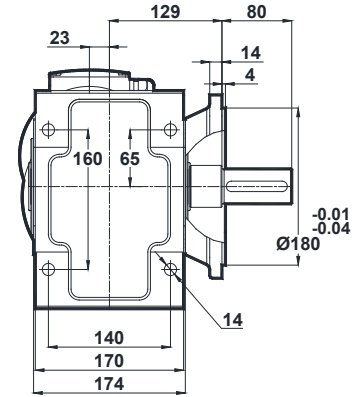
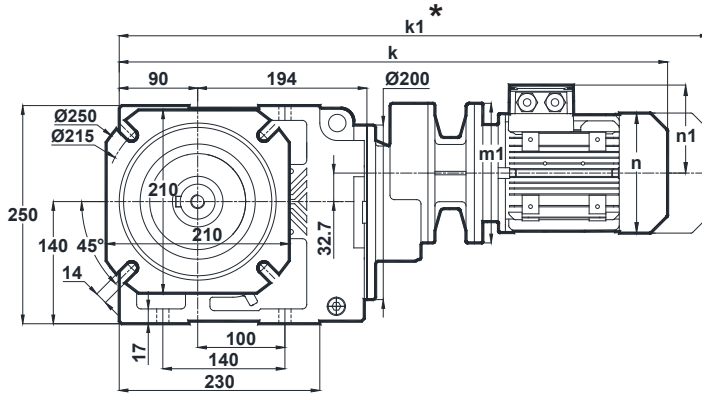

	63/B5	71/B5 71/B14	80/B5 80/B14
k	620.5	609.5	661.5
k1	681.5	700.5	754.5
n / n1	121 / 97	137 / 121	155 / 123
m1 (B5)	140	160	200
m1 (B14)	-	105	120

Klemens Pozisyonları
Terminal Box Positions
Klemmenkasten Positionen

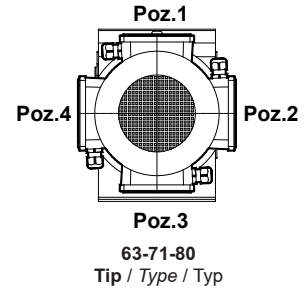

Opsiyonel flanş ölçüleri için sayfa 587'ye bakınız.
Please see on page 587 for optional flange dimensions
Siehe Seite 587 für auswählbare Flanschabmessungen

KV374.03

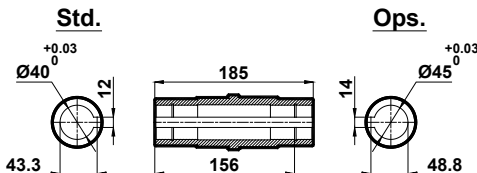
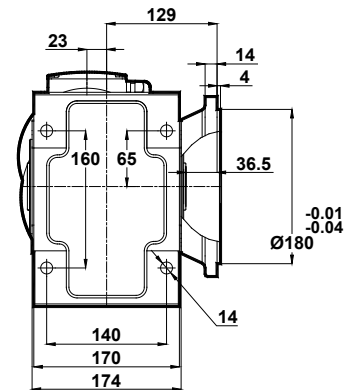
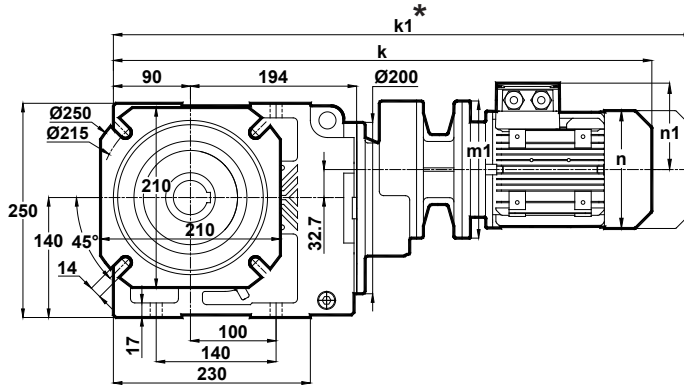

	63/B5	71/B5 71/B14	80/B5 80/B14
k	620.5	609.5	661.5
k1	681.5	700.5	754.5
n / n1	121 / 97	137 / 121	155 / 123
m1 (B5)	140	160	200
m1 (B14)	-	105	120

Opsiyonel flanş ölçüleri için sayfa 587'ye bakınız.
Please see on page 587 for optional flange dimensions
Siehe Seite 587 für auswählbare Flanschabmessungen

* " k1 " Ölçüsü frenli redüktörlere aittir.
Dimension " k1 " is for motors with brake.
Maße " k1 " ist für Bremsenmotoren.

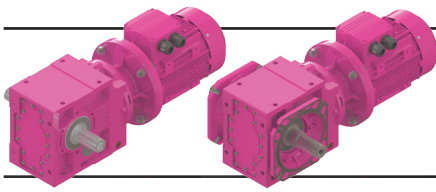

Ölçü Sayfaları

Dimension Pages

Abmessungsseiten

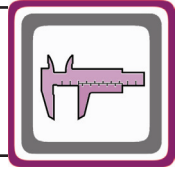

-Mil ucu çektirme deliği DIN 332 sayfa 2 / Tapped center hole to DIN 332, sheet 2 / Zentrierung mit Gewinde DIN 332, Blatt 2

KV374.04

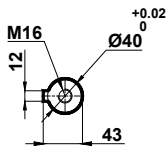
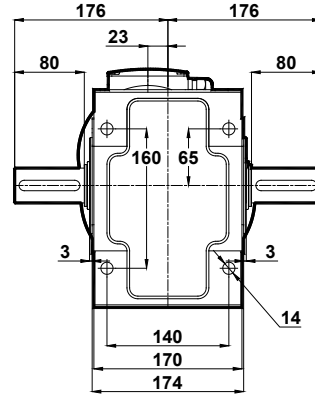
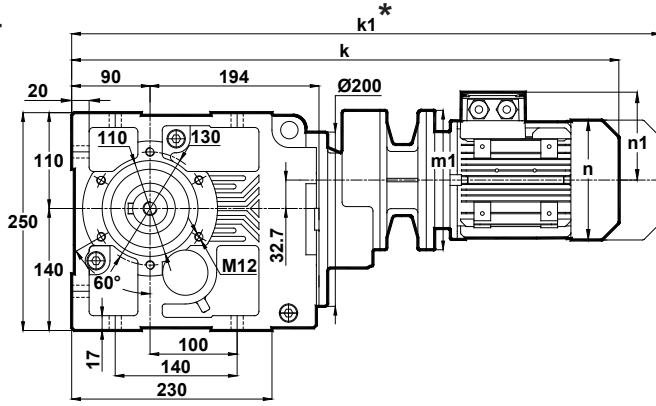

	63/B5	71/B5 71/B14	80/B5 80/B14
k	620.5	609.5	661.5
k1	681.5	700.5	754.5
n / n1	121 / 97	137 / 121	155 / 123
m1 (B5)	140	160	200
m1 (B14)	-	105	120

Klemens Pozisyonları
Terminal Box Positions
Klemmenkasten Positionen

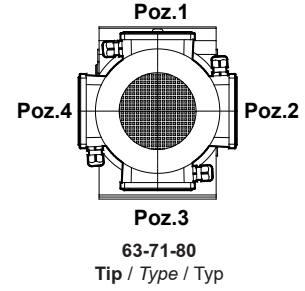

KV374.05

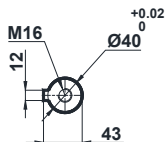
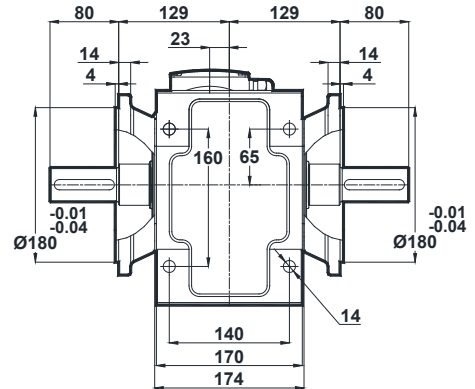
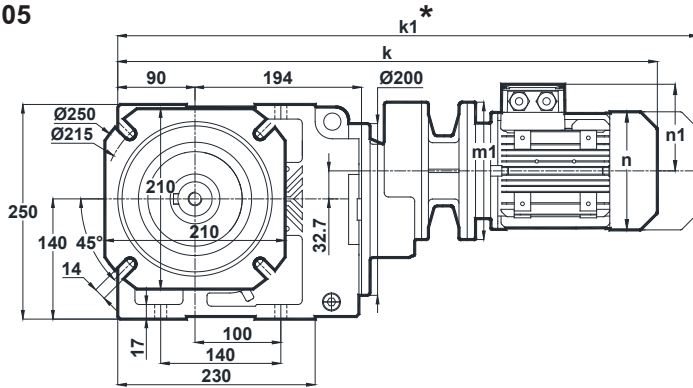

	63/B5	71/B5 71/B14	80/B5 80/B14
k	620.5	609.5	661.5
k1	681.5	700.5	754.5
n / n1	121 / 97	137 / 121	155 / 123
m1 (B5)	140	160	200
m1 (B14)	-	105	120

Opsiyonel flanş ölçüleri için sayfa 587'ye bakınız.
Please see on page 587 for optional flange dimensions
Siehe Seite 587 für auswählbare Flanschabmessungen

* " k1 " Ölçüsü frenli redüktörlere aittir.
Dimension " k1 " is for motors with brake.
Maße " k1 " ist für Bremsenmotoren.

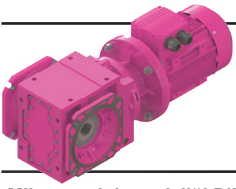

Ölçü Sayfaları Dimension Pages Abmessungenseiten

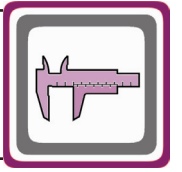

-Mil ucu çektirme deliği DIN 332 sayfa 2 / Tapped center hole to DIN 332, sheet 2 / Zentrierung mit Gewinde DIN 332, Blatt 2

KV374.08

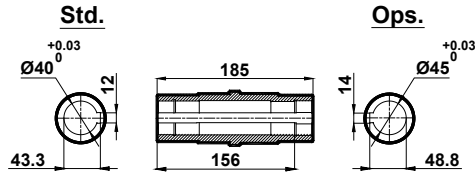
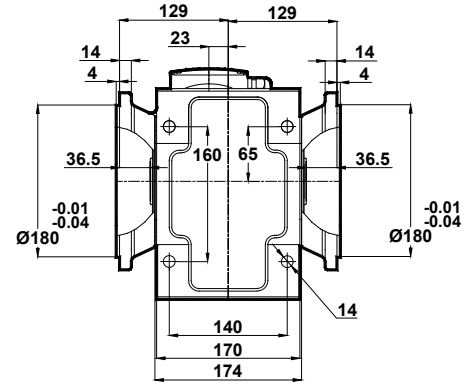
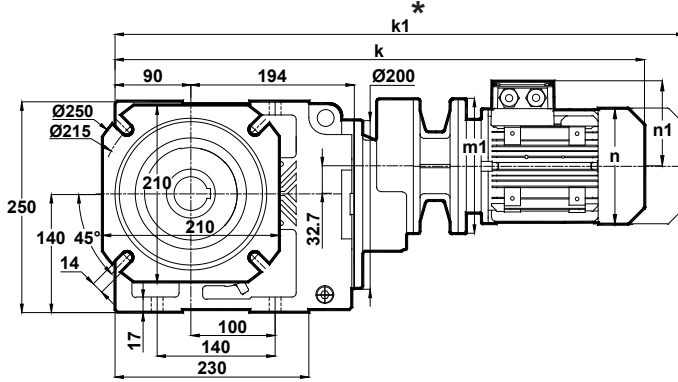

Klemens Pozisyonları
Terminal Box Positions
Klemmenkasten Positionen

	63/B5	71/B5 71/B14	80/B5 80/B14
k	620.5	609.5	661.5
k1	681.5	700.5	754.5
n / n1	121 / 97	137 / 121	155 / 123
m1 (B5)	140	160	200
m1 (B14)	-	105	120

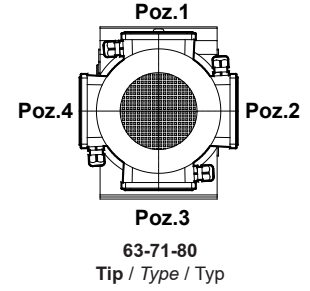

Opsiyonel flanş ölçüleri için sayfa 587'ye bakınız.
Please see on page 587 for optional flange dimensions
Siehe Seite 587 für auswählbare Flanschabmessungen

* " k1 " Ölçüsü frenli redüktörlere aittir.
Dimension " k1 " is for motors with brake.
Maße " k1 " ist für Bremsenmotoren.

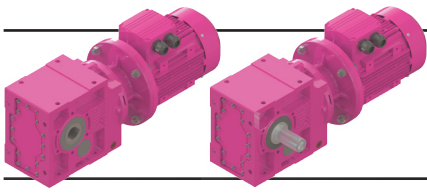

Ölçü Sayfaları

Dimension Pages

Abmessungsseiten

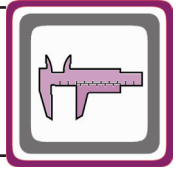

-Mil ucu çektirme deliği DIN 332 sayfa 2 / Tapped center hole to DIN 332, sheet 2 / Zentrierung mit Gewinde DIN 332, Blatt 2

KV375.00
KV376.00

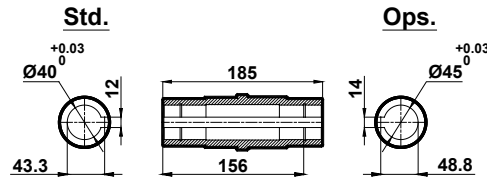
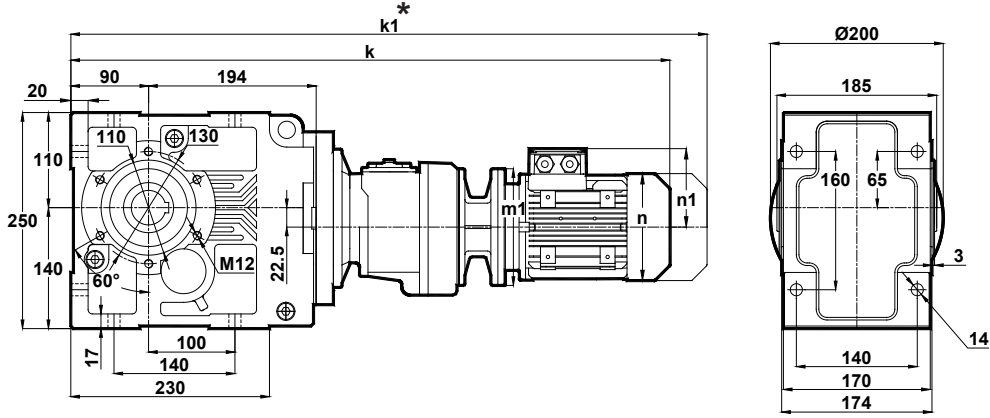

Klemens Pozisyonları
Terminal Box Positions
Klemmenkasten Positionen

	63/B5 63/B14	71/B5 71/B14
k	686	705.5
k1	747	796.5
n / n1	121 / 97	137 / 112
m1 (B5)	140	160
m1 (B14)	90	105

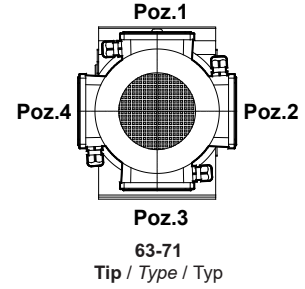

KV375.01
KV376.01

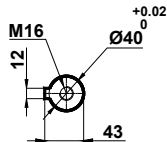
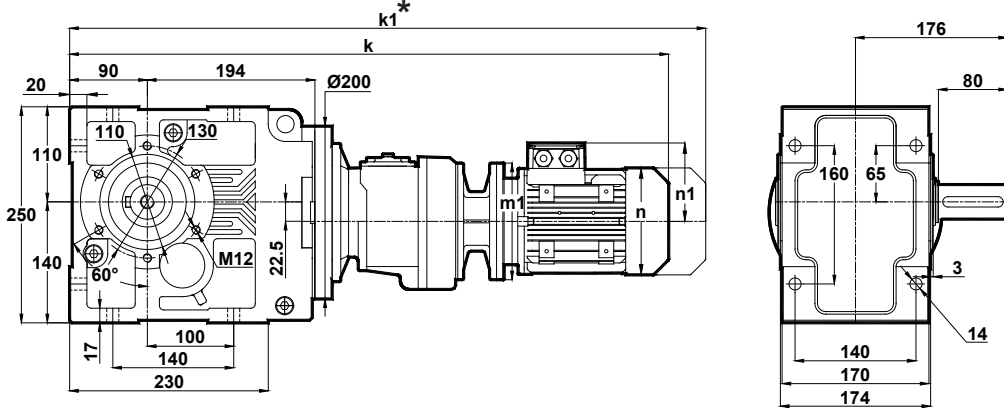

	63/B5 63/B14	71/B5 71/B14
k	686	705.5
k1	747	796.5
n / n1	121 / 97	137 / 112
m1 (B5)	140	160
m1 (B14)	90	105

* " k1 " Ölçüsü frenli redüktörlere aittir.
Dimension " k1 " is for motors with brake.
Maße " k1 " ist für Bremsmotoren.

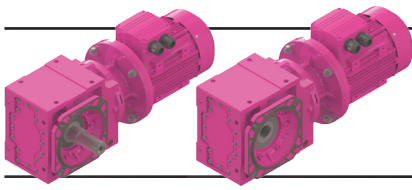

Ölçü Sayfaları

Dimension Pages

Abmessungsseiten

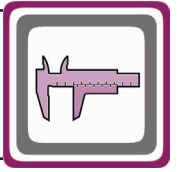

-Mil ucu çekirme deliği DIN 332 sayfa 2 / Tapped center hole to DIN 332, sheet 2 / Zentrierung mit Gewinde DIN 332, Blatt 2

KV375.02
KV376.02

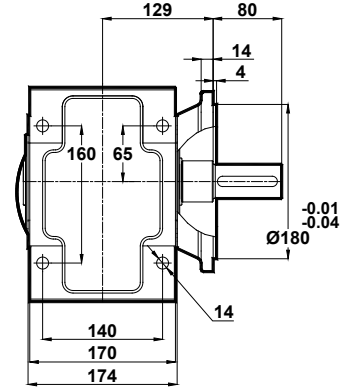
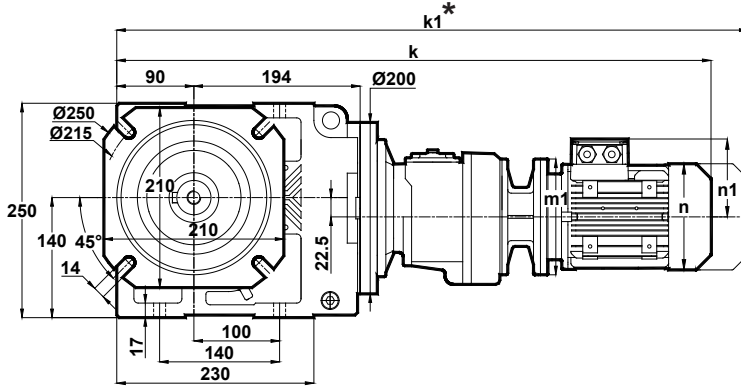

Klemens Pozisyonları
Terminal Box Positions
Klemmenkasten Positionen

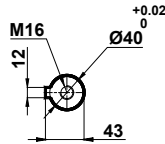
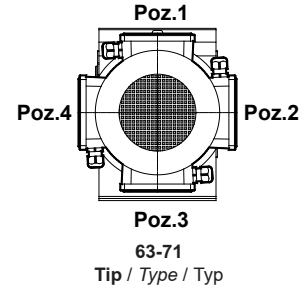

	63/B5 63/B14	71/B5 71/B14
k	686	705.5
k1	747	796.5
n / n1	121 / 97	137 / 112
m1 (B5)	140	160
m1 (B14)	90	105

Opsiyonel flanş ölçüleri için sayfa 587'ye bakınız.
Please see on page 587 for optional flange dimensions
Siehe Seite 587 für auswählbare Flanschabmessungen

KV375.03
KV376.03

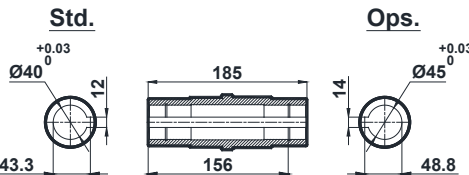
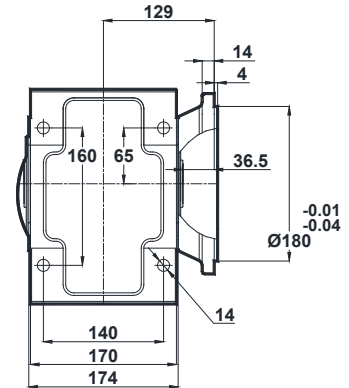
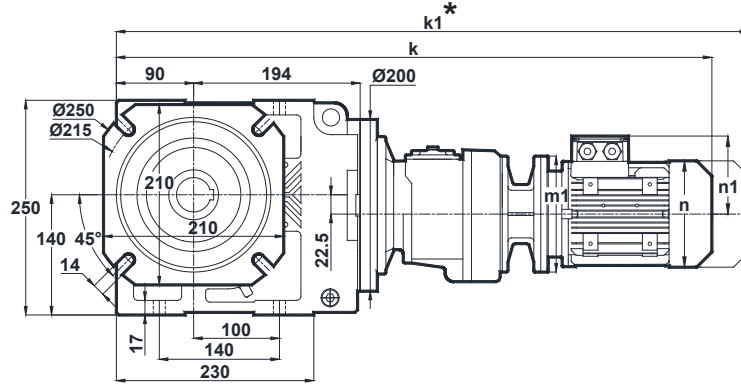

	63/B5 63/B14	71/B5 71/B14
k	686	705.5
k1	747	796.5
n / n1	121 / 97	137 / 112
m1 (B5)	140	160
m1 (B14)	90	105

Opsiyonel flanş ölçüleri için sayfa 587'ye bakınız.
Please see on page 587 for optional flange dimensions
Siehe Seite 587 für auswählbare Flanschabmessungen

* " k1 " Ölçüsü frenli redüktörlere aittir.
Dimension " k1 " is for motors with brake.
Maße " k1 " ist für Bremsenmotoren.

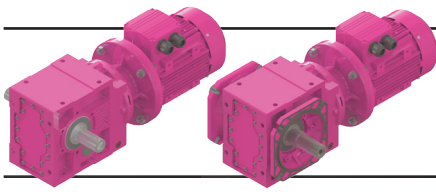

Ölçü Sayfaları

Dimension Pages

Abmessungsseiten

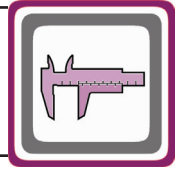

-Mil ucu çektirme deliği DIN 332 sayfa 2 / Tapped center hole to DIN 332, sheet 2 / Zentrierung mit Gewinde DIN 332, Blatt 2

KV375.04
KV376.04

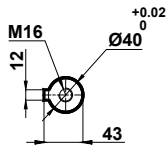
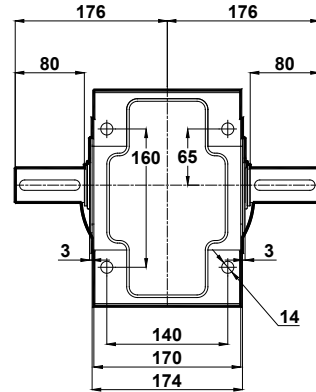
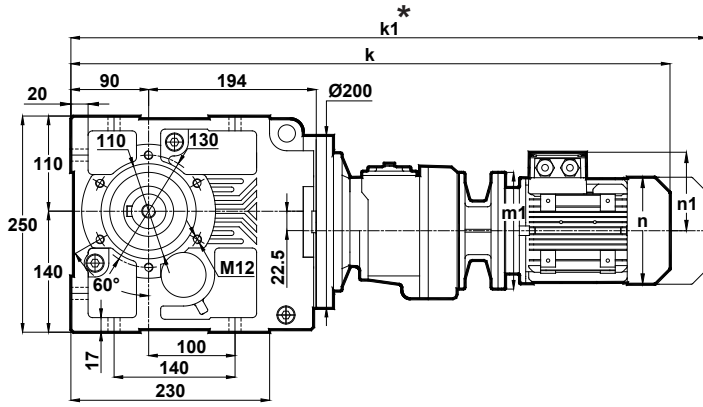

	63/B5 63/B14	71/B5 71/B14
k	686	705.5
k1	747	796.5
n / n1	121 / 97	137 / 112
m1 (B5)	140	160
m1 (B14)	90	105

Klemens Pozisyonları
Terminal Box Positions
Klemmenkasten Positionen

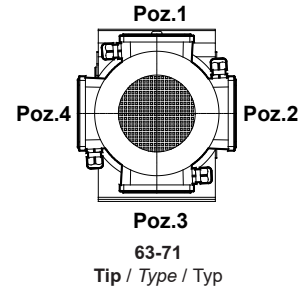

KV375.05
KV376.05

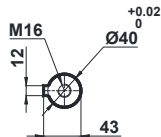
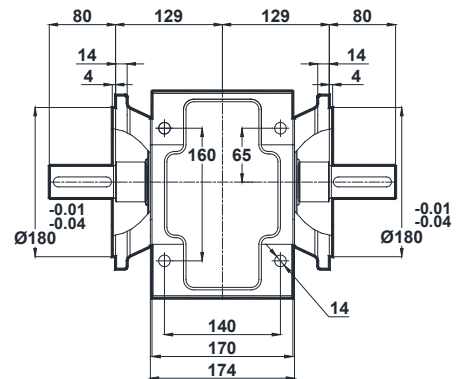
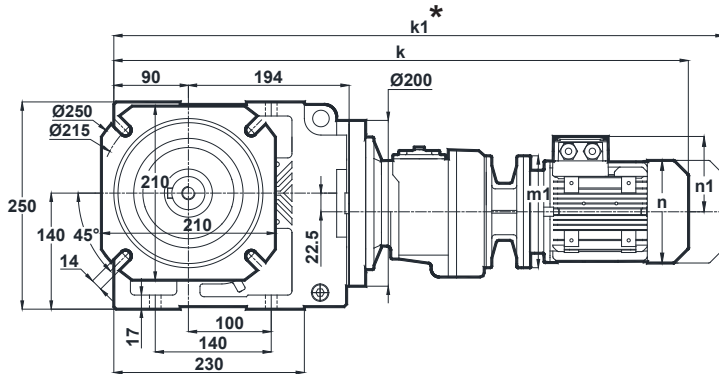

	63/B5 63/B14	71/B5 71/B14
k	686	705.5
k1	747	796.5
n / n1	121 / 97	137 / 112
m1 (B5)	140	160
m1 (B14)	90	105

Opsiyonel flanş ölçüleri için sayfa 587'ye bakınız.
Please see on page 587 for optional flange dimensions
Siehe Seite 587 für auswählbare Flanschabmessungen

* " k1 " Ölçüsü frenli redüktörlere aittir.
Dimension " k1 " is for motors with brake.
Maße " k1 " ist für Bremsenmotoren.

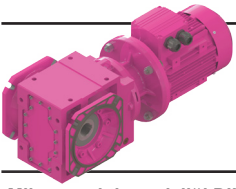

Ölçü Sayfaları Dimension Pages Abmessungsseiten



-Mil ucu çekirme deliği DIN 332 sayfa 2 / Tapped center hole to DIN 332, sheet 2 / Zentrierung mit Gewinde DIN 332, Blatt 2

KV375.08
KV376.08

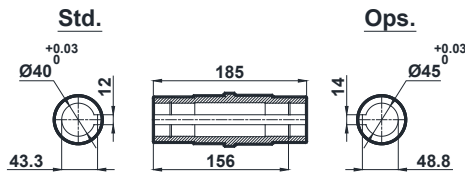
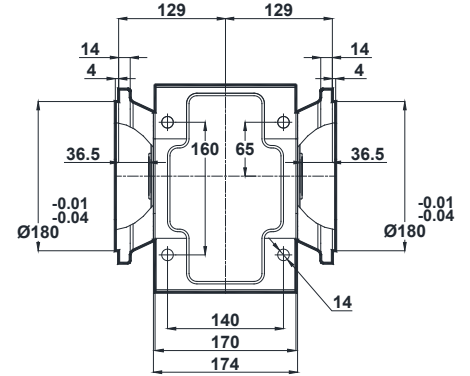
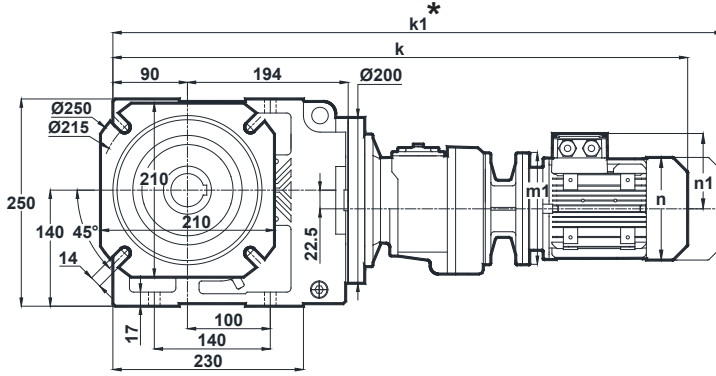

Klemens Pozisyonları
Terminal Box Positions
Klemmenkasten Positionen

	63/B5 63/B14	71/B5 71/B14
k	686	705.5
k1	747	796.5
n / n1	121 / 97	137 / 112
m1 (B5)	140	160
m1 (B14)	90	105

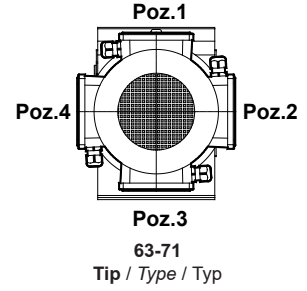

Opsiyonel flanş ölçüleri için sayfa 587'ye bakınız.
Please see on page 587 for optional flange dimensions
Siehe Seite 587 für auswählbare Flanschabmessungen

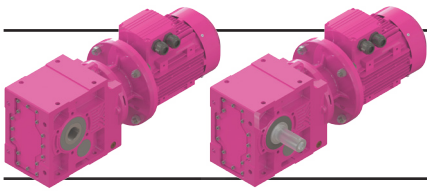

Ölçü Sayfaları

Dimension Pages

Abmessungsseiten

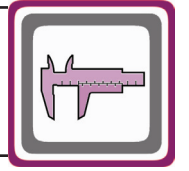

-Mil ucu çektirme deliği DIN 332 sayfa 2 / Tapped center hole to DIN 332, sheet 2 / Zentrierung mit Gewinde DIN 332, Blatt 2

KV473.00

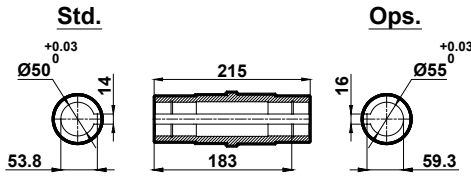
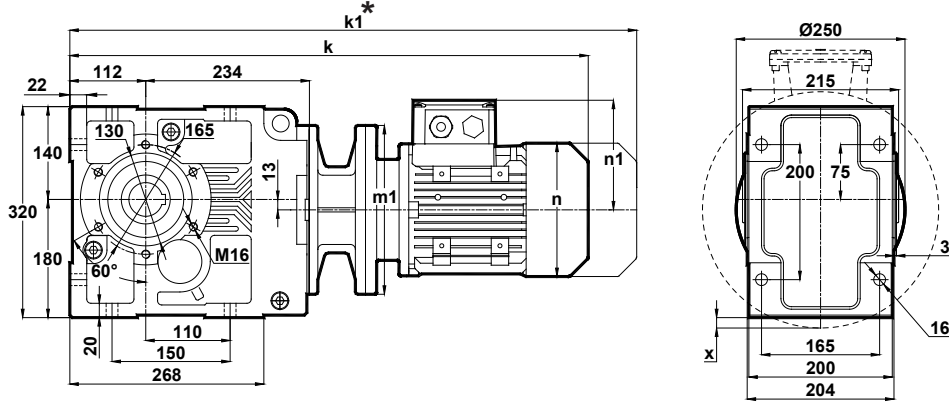

x: Motor Ayak bağlantı yüzeyinin altında ise
x: If Motor is lower than foot mounting plane
x: Wenn der Motor unter der Fußmontageebene ist

Klemens Pozisyonları
Terminal Box Positions
Klemmenkasten Positionen

	80/B5	90S/B5 90S/B14	90L/B5 90L/B14	100L/B5 100L/B14	112M/B5 112M/B14	132S/B5 132S/B14	132M/B5 132M/B14	160M/B5	160L/B5	180M/B5	180L/B5
k	636.5	677.5	677.5	731.5	752	854.5	854.5	1014	1014	1102	1102
k1	729.5	781	781	840	856.5	984.5	984.5	1162	1162	1260.5	1260.5
n / n1	155 / 123	176 / 132	176 / 132	193 / 149	215 / 161	257 / 181	257 / 181	316 / 224	316 / 224	348 / 250	348 / 250
m1 (B5)	200	200	200	250	250	300	300	350	350	350	350
m1 (B14)	-	140	140	160	160	200	200	-	-	-	-
x	-	-	-	-	-	-	-	8	8	8	8

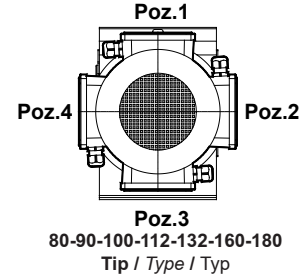

KV473.01

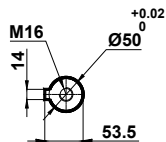
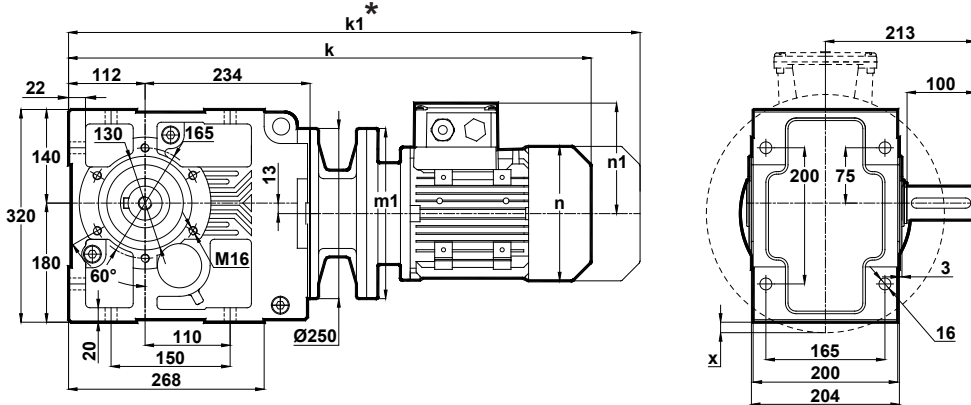

x: Motor Ayak bağlantı yüzeyinin altında ise
x: If Motor is lower than foot mounting plane
x: Wenn der Motor unter der Fußmontageebene ist

	80/B5	90S/B5 90S/B14	90L/B5 90L/B14	100L/B5 100L/B14	112M/B5 112M/B14	132S/B5 132S/B14	132M/B5 132M/B14	160M/B5	160L/B5	180M/B5	180L/B5
k	636.5	677.5	677.5	731.5	752	854.5	854.5	1014	1014	1102	1102
k1	729.5	781	781	840	856.5	984.5	984.5	1162	1162	1260.5	1260.5
n / n1	155 / 123	176 / 132	176 / 132	193 / 149	215 / 161	257 / 181	257 / 181	316 / 224	316 / 224	348 / 250	348 / 250
m1 (B5)	200	200	200	250	250	300	300	350	350	350	350
m1 (B14)	-	140	140	160	160	200	200	-	-	-	-
x	-	-	-	-	-	-	-	8	8	8	8

* "k1" Ölçüsü frenli redüktörlere aittir.
Dimension "k1" is for motors with brake.
Maße "k1" ist für Bremsenmotoren.

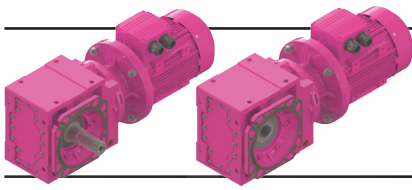

Ölçü Sayfaları

Dimension Pages

Abmessungsseiten

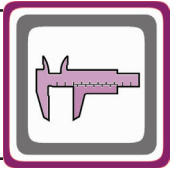

-Mil ucu çektirme deliği DIN 332 sayfa 2 / Tapped center hole to DIN 332, sheet 2 / Zentrierung mit Gewinde DIN 332, Blatt 2

KV473.02

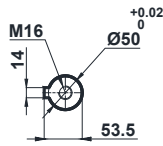
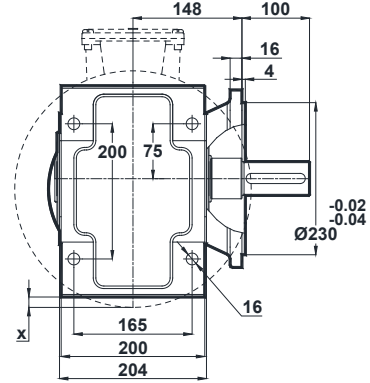
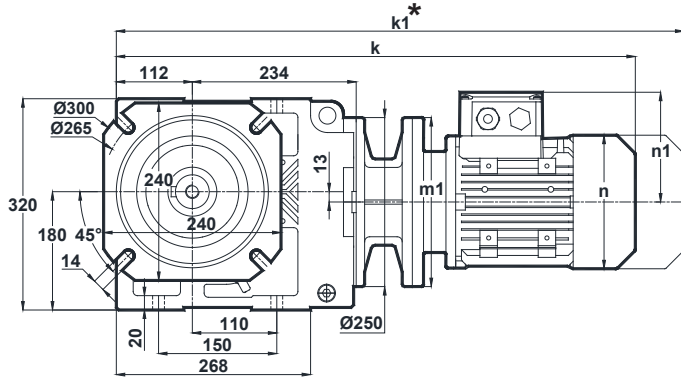

x: Motor Ayak bağlantı yüzeyinin altında ise
x: If Motor is lower than foot mounting plane
x: Wenn der Motor unter der Fußmontageebene ist

Klemens Pozisyonları
Terminal Box Positions
Klemmenkasten Positionen

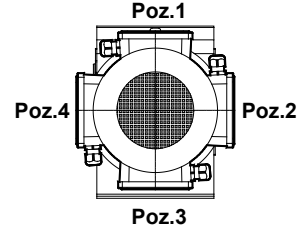

80-90-100-112-132-160-180
Tip / Type / Typ

	80/B5	90S/B5 90S/B14	90L/B5 90L/B14	100L/B5 100L/B14	112M/B5 112M/B14	132S/B5 132S/B14	132M/B5 132M/B14	160M/B5	160L/B5	180M/B5	180L/B5
k	636.5	677.5	677.5	731.5	752	854.5	854.5	1014	1014	1102	1102
k1	729.5	781	781	840	856.5	984.5	984.5	1162	1162	1260.5	1260.5
n / n1	155 / 123	176 / 132	176 / 132	193 / 149	215 / 161	257 / 181	257 / 181	316 / 224	316 / 224	348 / 250	348 / 250
m1 (B5)	200	200	200	250	250	300	300	350	350	350	350
m1 (B14)	-	140	140	160	160	200	200	-	-	-	-
x	-	-	-	-	-	-	-	8	8	8	8

Opsiyonel flanş ölçüleri için sayfa 587'ye bakınız.
Please see on page 587 for optional flange dimensions
Siehe Seite 587 für auswählbare Flanschabmessungen

KV473.03

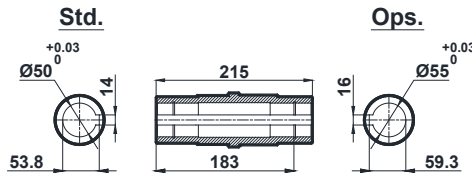
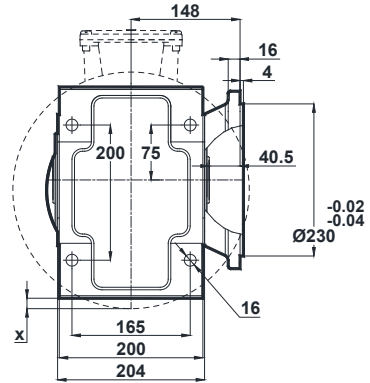
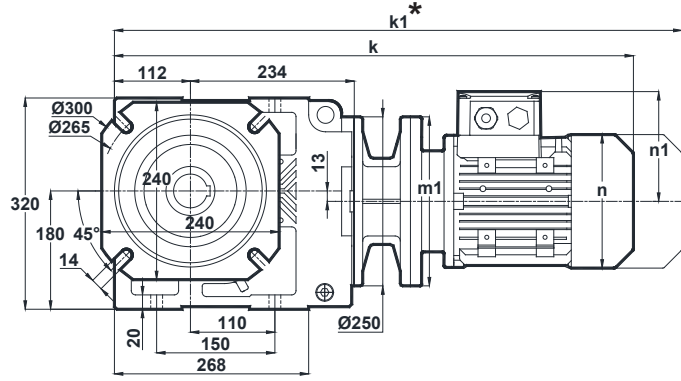

x: Motor Ayak bağlantı yüzeyinin altında ise
x: If Motor is lower than foot mounting plane
x: Wenn der Motor unter der Fußmontageebene ist

	80/B5	90S/B5 90S/B14	90L/B5 90L/B14	100L/B5 100L/B14	112M/B5 112M/B14	132S/B5 132S/B14	132M/B5 132M/B14	160M/B5	160L/B5	180M/B5	180L/B5
k	636.5	677.5	677.5	731.5	752	854.5	854.5	1014	1014	1102	1102
k1	729.5	781	781	840	856.5	984.5	984.5	1162	1162	1260.5	1260.5
n / n1	155 / 123	176 / 132	176 / 132	193 / 149	215 / 161	257 / 181	257 / 181	316 / 224	316 / 224	348 / 250	348 / 250
m1 (B5)	200	200	200	250	250	300	300	350	350	350	350
m1 (B14)	-	140	140	160	160	200	200	-	-	-	-
x	-	-	-	-	-	-	-	8	8	8	8

Opsiyonel flanş ölçüleri için sayfa 587'ye bakınız.
Please see on page 587 for optional flange dimensions
Siehe Seite 587 für auswählbare Flanschabmessungen

* "k1" Ölçüsü frenli redüktörlere aittir.
Dimension "k1" is for motors with brake.
Maße "k1" ist für Bremsenmotoren.

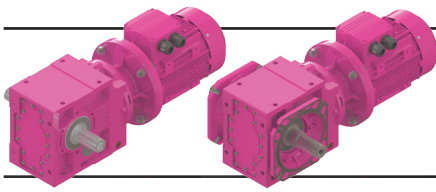

Ölçü Sayfaları

Dimension Pages

Abmessungsseiten

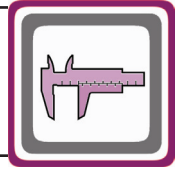

-Mil ucu çektirme deliği DIN 332 sayfa 2 / Tapped center hole to DIN 332, sheet 2 / Zentrierung mit Gewinde DIN 332, Blatt 2

KV473.04

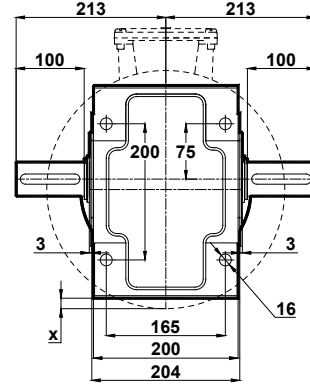
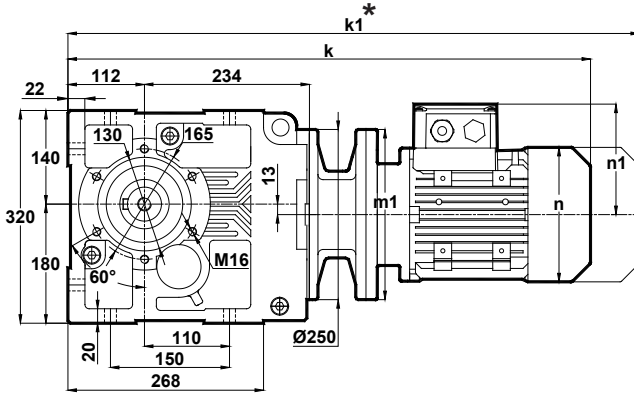

x: Motor Ayak bağlantı yüzeyinin altında ise
x: If Motor is lower than foot mounting plane
x: Wenn der Motor unter der Fußmontageebene ist

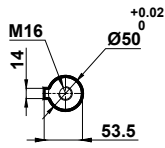

Klemens Pozisyonları
Terminal Box Positions
Klemmenkasten Positionen

	80/B5	90S/B5 90S/B14	90L/B5 90L/B14	100L/B5 100L/B14	112M/B5 112M/B14	132S/B5 132S/B14	132M/B5 132M/B14	160M/B5	160L/B5	180M/B5	180L/B5
k	636.5	677.5	677.5	731.5	752	854.5	854.5	1014	1014	1102	1102
k1	729.5	781	781	840	856.5	984.5	984.5	1162	1162	1260.5	1260.5
n / n1	155 / 123	176 / 132	176 / 132	193 / 149	215 / 161	257 / 181	257 / 181	316 / 224	316 / 224	348 / 250	348 / 250
m1 (B5)	200	200	200	250	250	300	300	350	350	350	350
m1 (B14)	-	140	140	160	160	200	200	-	-	-	-
x	-	-	-	-	-	-	-	8	8	8	8

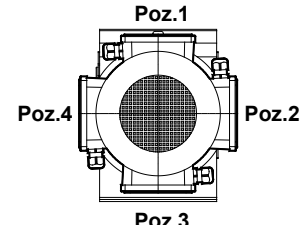

80-90-100-112-132-160-180
Tip / Type / Typ

KV473.05

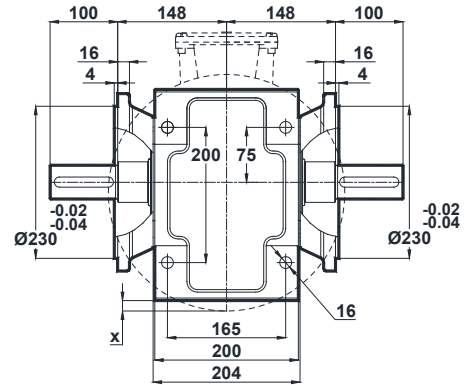
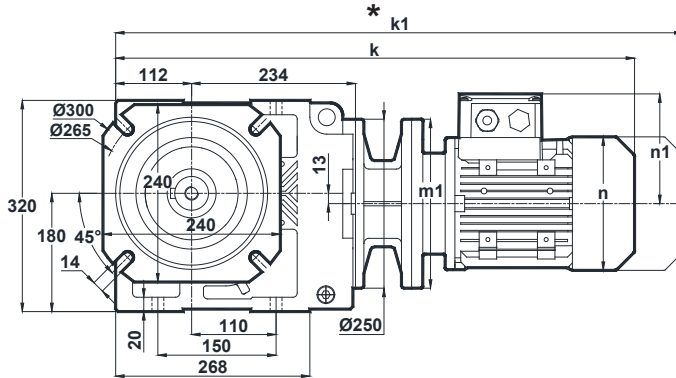

x: Motor Ayak bağlantı yüzeyinin altında ise
x: If Motor is lower than foot mounting plane
x: Wenn der Motor unter der Fußmontageebene ist

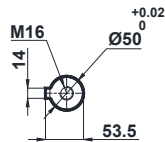

Opsiyonel flanş ölçüleri için sayfa 587'ye bakınız.
Please see on page 587 for optional flange dimensions
Siehe Seite 587 für auswählbare Flanschabmessungen

	80/B5	90S/B5 90S/B14	90L/B5 90L/B14	100L/B5 100L/B14	112M/B5 112M/B14	132S/B5 132S/B14	132M/B5 132M/B14	160M/B5	160L/B5	180M/B5	180L/B5
k	636.5	677.5	677.5	731.5	752	854.5	854.5	1014	1014	1102	1102
k1	729.5	781	781	840	856.5	984.5	984.5	1162	1162	1260.5	1260.5
n / n1	155 / 123	176 / 132	176 / 132	193 / 149	215 / 161	257 / 181	257 / 181	316 / 224	316 / 224	348 / 250	348 / 250
m1 (B5)	200	200	200	250	250	300	300	350	350	350	350
m1 (B14)	-	140	140	160	160	200	200	-	-	-	-
x	-	-	-	-	-	-	-	8	8	8	8

* "k1" Ölçüsü frenli redüktörlere aittir.
Dimension "k1" is for motors with brake.
Maße "k1" ist für Bremsenmotoren.

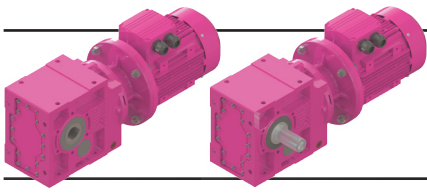

Ölçü Sayfaları

Dimension Pages

Abmessungsseiten

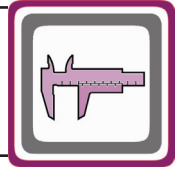

-Mil ucu çektirme deliği DIN 332 sayfa 2 / Tapped center hole to DIN 332, sheet 2 / Zentrierung mit Gewinde DIN 332, Blatt 2

KV474.00

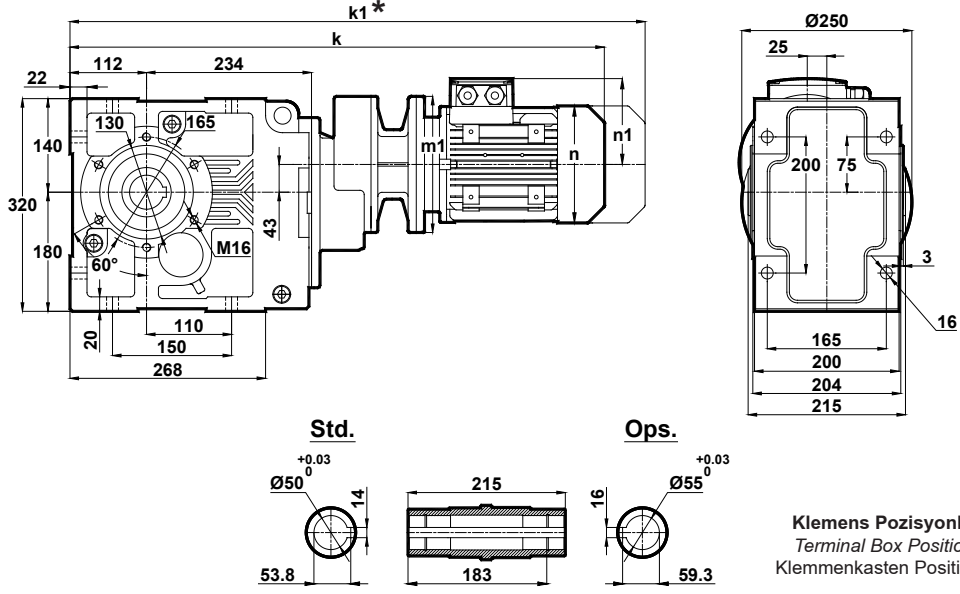

	71/B5	80/B5 80/B14
k	711.5	734.5
k1	802.5	827.5
n / n1	137 / 112	155 / 123
m1 (B5)	160	200
m1 (B14)	-	120

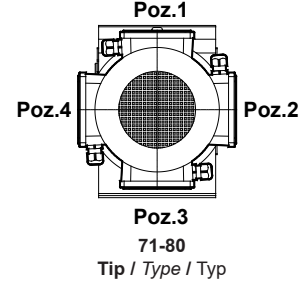

KV474.01

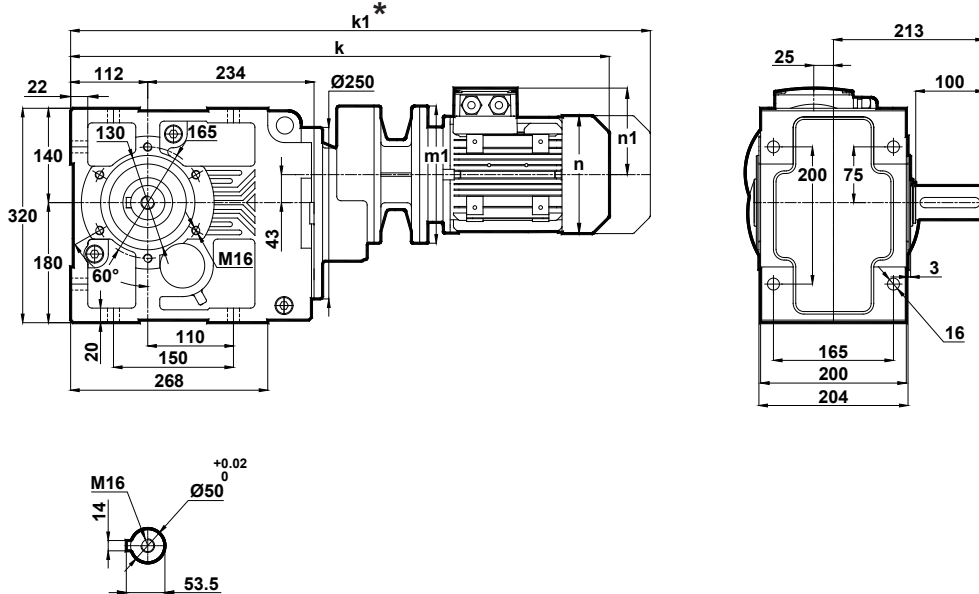

	71/B5	80/B5 80/B14
k	711.5	734.5
k1	802.5	827.5
n / n1	137 / 112	155 / 123
m1 (B5)	160	200
m1 (B14)	-	120

* " k1 " Ölçüsü frenli redüktörlere aittir.
Dimension " k1 " is for motors with brake.
Maße " k1 " ist für Bremsenmotoren.

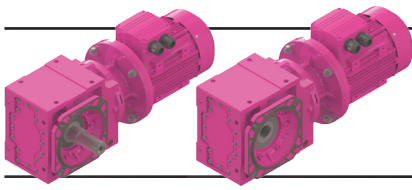

Ölçü Sayfaları

Dimension Pages

Abmessungsseiten



-Mil ucu çektirme deliği DIN 332 sayfa 2 / Tapped center hole to DIN 332, sheet 2 / Zentrierung mit Gewinde DIN 332, Blatt 2

KV474.02

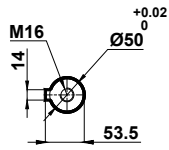
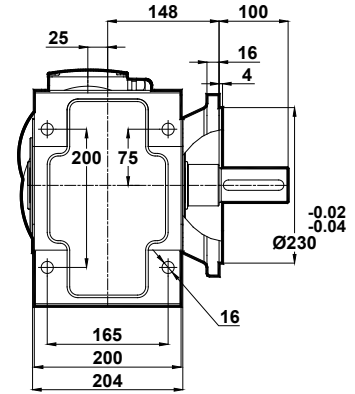
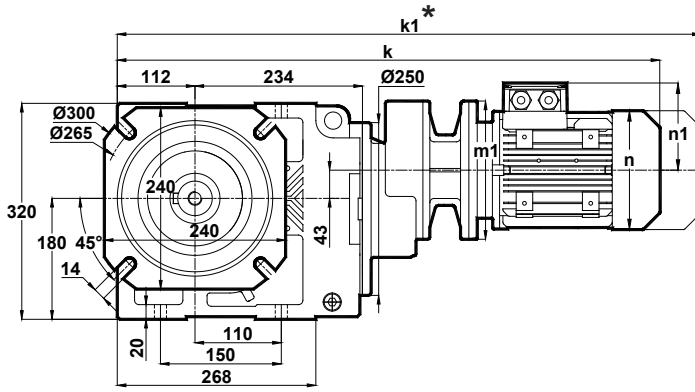

	71/B5	80/B5 80/B14
k	711.5	734.5
k1	802.5	827.5
n / n1	137 / 112	155 / 123
m1 (B5)	160	200
m1 (B14)	-	120

Klemens Pozisyonları
Terminal Box Positions
Klemmenkasten Positionen

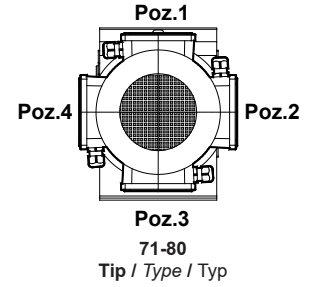

Opsiyonel flanş ölçüleri için sayfa 587'ye bakınız.
Please see on page 587 for optional flange dimensions
Siehe Seite 587 für auswählbare Flanschabmessungen

KV474.03

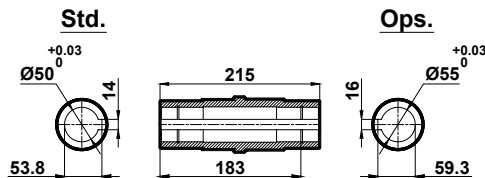
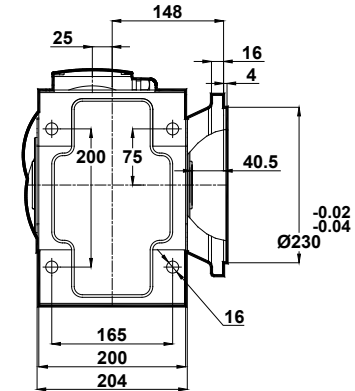
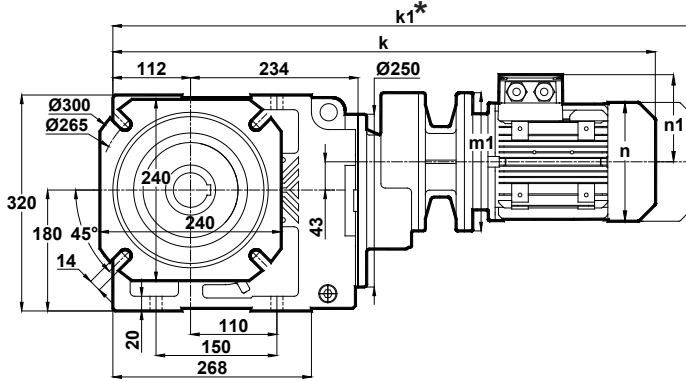

	71/B5	80/B5 80/B14
k	711.5	734.5
k1	802.5	827.5
n / n1	137 / 112	155 / 123
m1 (B5)	160	200
m1 (B14)	-	120

Opsiyonel flanş ölçüleri için sayfa 587'ye bakınız.
Please see on page 587 for optional flange dimensions
Siehe Seite 587 für auswählbare Flanschabmessungen

* " k1 " Ölçüsü frenli redüktörlere aittir.
Dimension " k1 " is for motors with brake.
Maße " k1 " ist für Bremsenmotoren.

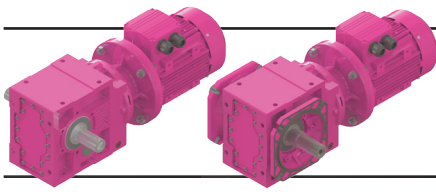

Ölçü Sayfaları Dimension Pages Abmessungsseiten

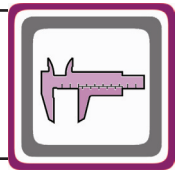

-Mil ucu çekirme deliği DIN 332 sayfa 2 / Tapped center hole to DIN 332, sheet 2 / Zentrierung mit Gewinde DIN 332, Blatt 2

KV474.04

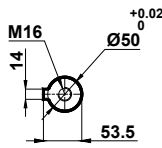
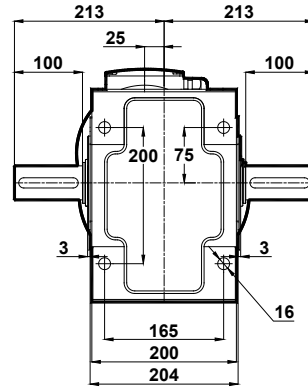
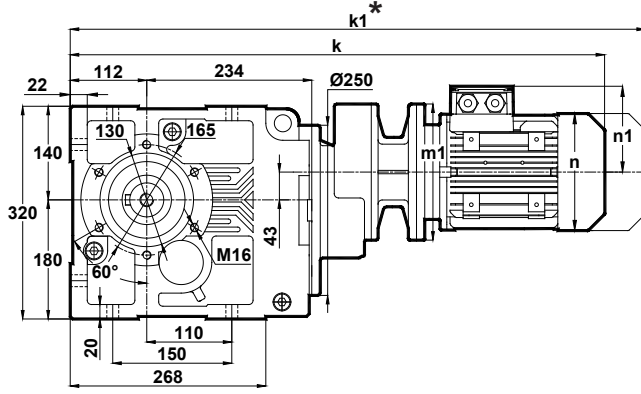

	71/B5	80/B5 80/B14
k	711.5	734.5
k1	802.5	827.5
n / n1	137 / 112	155 / 123
m1 (B5)	160	200
m1 (B14)	-	120

Klemens Pozisyonları
Terminal Box Positions
Klemmenkasten Positionen

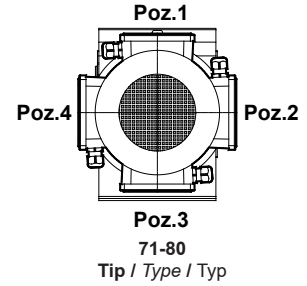

KV474.05

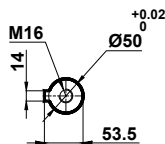
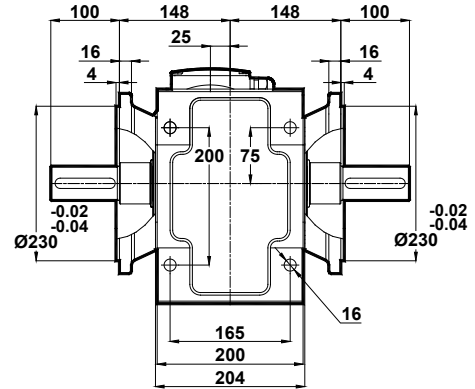
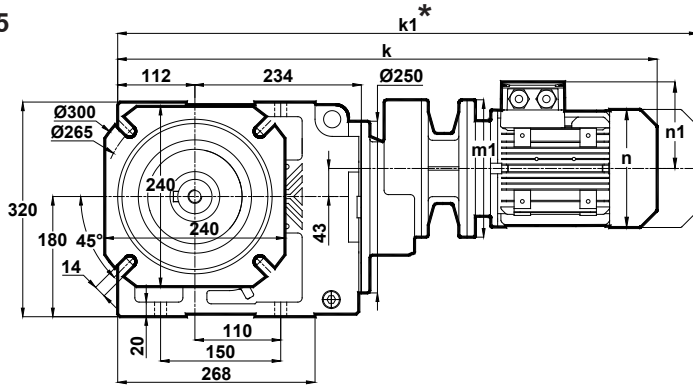

	71/B5	80/B5 80/B14
k	711.5	734.5
k1	802.5	827.5
n / n1	137 / 112	155 / 123
m1 (B5)	160	200
m1 (B14)	-	120

Opsiyonel flanş ölçüleri için sayfa 587'ye bakınız.
Please see on page 587 for optional flange dimensions
Siehe Seite 587 für auswählbare Flanschabmessungen

* " k1 " Ölçüsü frenli redüktörlere aittir.
Dimension " k1 " is for motors with brake.
Maße " k1 " ist für Bremsenmotoren.

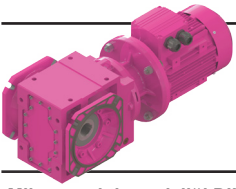

Ölçü Sayfaları Dimension Pages Abmessungsseiten



-Mil ucu çektirme deliği DIN 332 sayfa 2 / Tapped center hole to DIN 332, sheet 2 / Zentrierung mit Gewinde DIN 332, Blatt 2

KV474.08

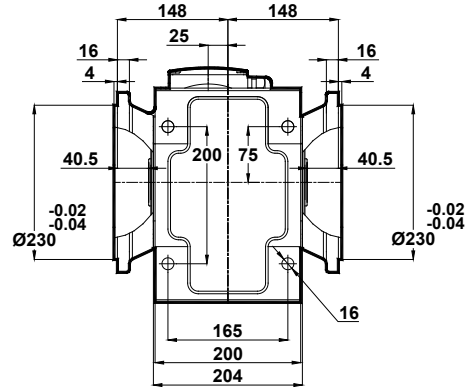
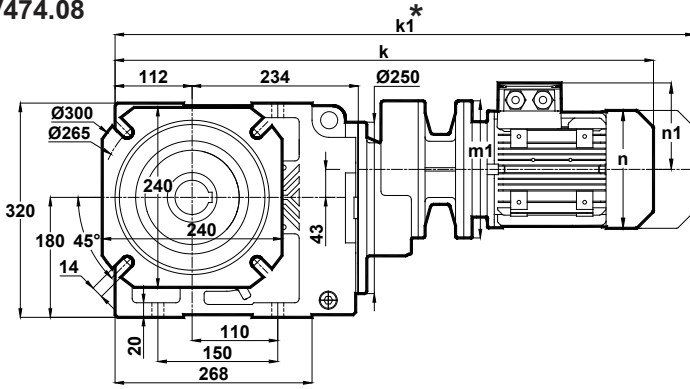

Std.

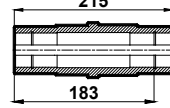
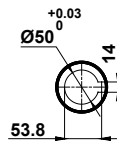

Ops.

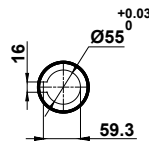

Klemens Pozisyonları
Terminal Box Positions
Klemmenkasten Positionen

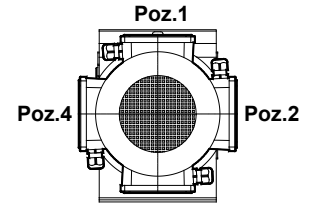

Poz.1

71-80

Tip / Type / Typ

	71/B5	80/B5 80/B14
k	711.5	734.5
k1	802.5	827.5
n / n1	137 / 112	155 / 123
m1 (B5)	160	200
m1 (B14)	-	120

Opsiyonel flanş ölçüleri için sayfa 587'ye bakınız.
Please see on page 587 for optional flange dimensions
Siehe Seite 587 für auswählbare Flanschabmessungen

* "k1" Ölçüsü frenli redüktörlere aittir.
Dimension "k1" is for motors with brake.
Maße "k1" ist für Bremsenmotoren.

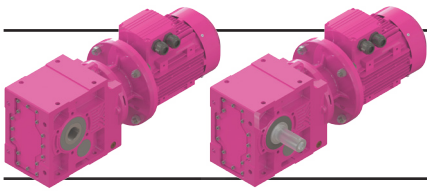

Ölçü Sayfaları

Dimension Pages

Abmessungsseiten

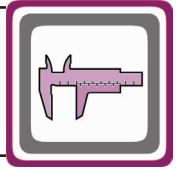

-Mil ucu çektirme deliği DIN 332 sayfa 2 / Tapped center hole to DIN 332, sheet 2 / Zentrierung mit Gewinde DIN 332, Blatt 2

KV475.00
KV476.00

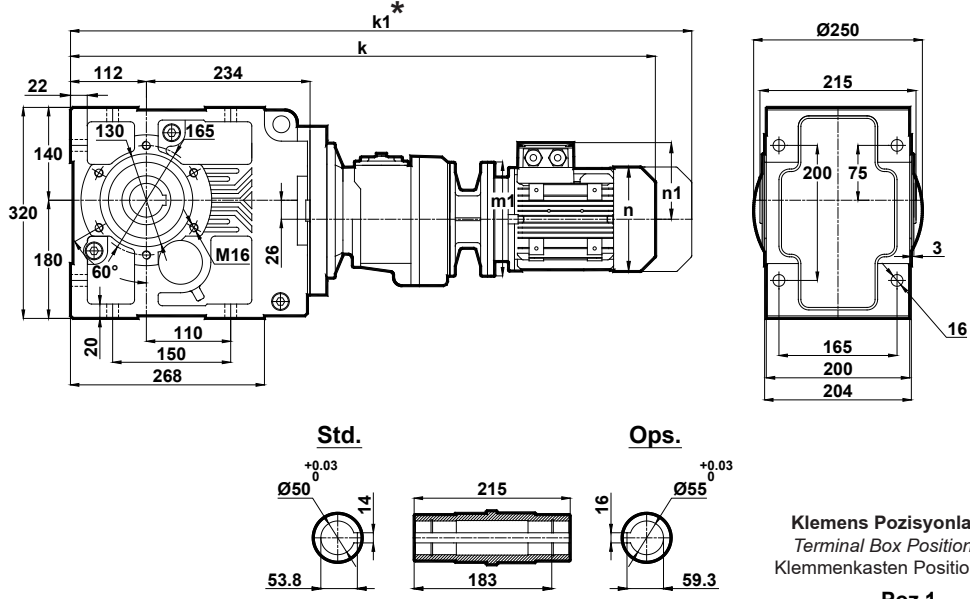

	63/B5	71/B5 71/B14
k	821.5	810.5
k1	882.5	901.5
n / n1	121 / 97	137 / 112
m1 (B5)	140	160
m1 (B14)	-	105

KV475.01
KV476.01

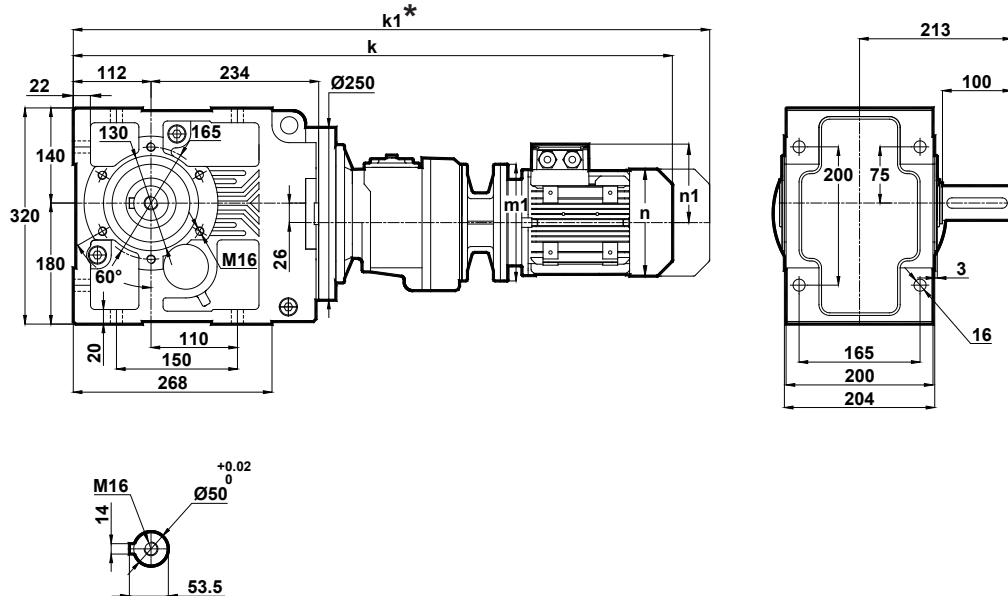

	63/B5	71/B5 71/B14
k	821.5	810.5
k1	882.5	901.5
n / n1	121 / 97	137 / 112
m1 (B5)	140	160
m1 (B14)	-	105

* " k1 " Ölçüsü frenli redüktörlere aittir.
Dimension " k1 " is for motors with brake.
Maße " k1 " ist für Bremsenmotoren.

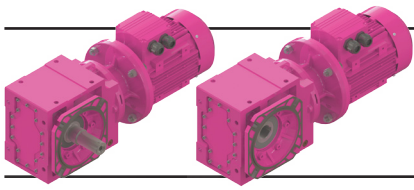

Ölçü Sayfaları

Dimension Pages

Abmessungsseiten

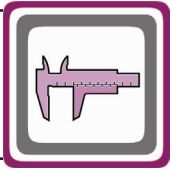

-Mil ucu çekirme deliği DIN 332 sayfa 2 / Tapped center hole to DIN 332, sheet 2 / Zentrierung mit Gewinde DIN 332, Blatt 2

KV475.02
KV476.02

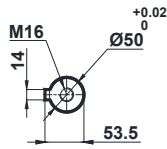
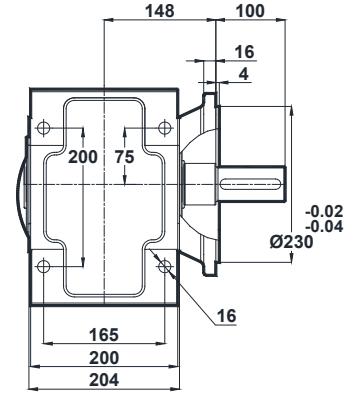
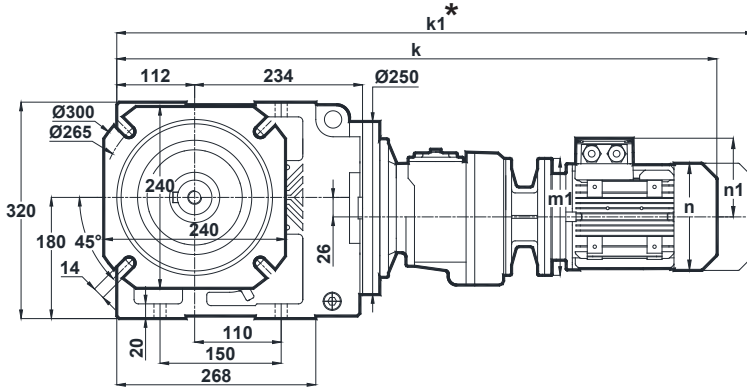

	63/B5	71/B5 71/B14
k	821.5	810.5
k1	882.5	901.5
n / n1	121 / 97	137 / 112
m1 (B5)	140	160
m1 (B14)	-	105

Klemens Pozisyonları
Terminal Box Positions
Klemmenkasten Positionen

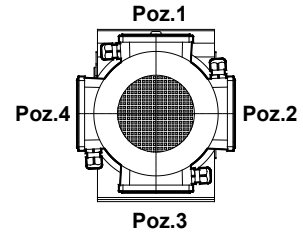

63-71
Tip / Type / Typ

Opsiyonel flanş ölçüleri için sayfa 587'ye bakınız.
Please see on page 587 for optional flange dimensions
Siehe Seite 587 für auswählbare Flanschabmessungen

KV475.03
KV476.03

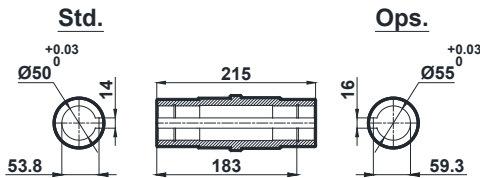
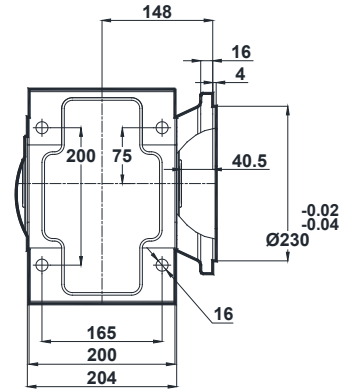
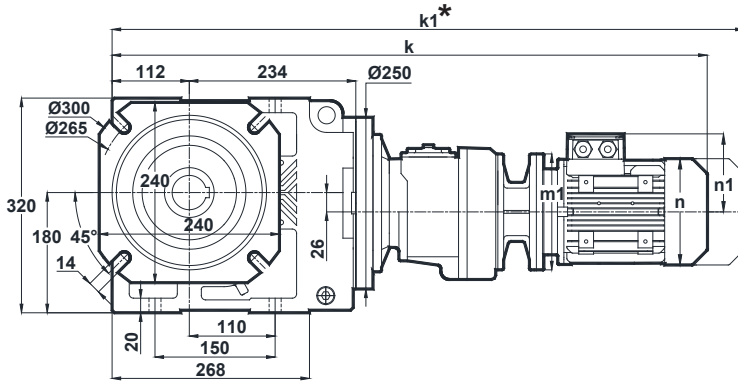

	63/B5	71/B5 71/B14
k	821.5	810.5
k1	882.5	901.5
n / n1	121 / 97	137 / 112
m1 (B5)	140	160
m1 (B14)	-	105

Opsiyonel flanş ölçüleri için sayfa 587'ye bakınız.
Please see on page 587 for optional flange dimensions
Siehe Seite 587 für auswählbare Flanschabmessungen

* " k1 " Ölçüsü frenli redüktörlere aittir.
Dimension " k1 " is for motors with brake.
Maße " k1 " ist für Bremsenmotoren.

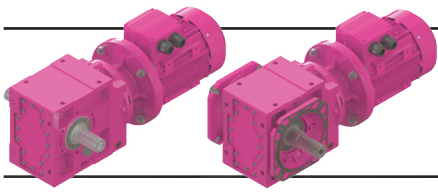

Ölçü Sayfaları

Dimension Pages

Abmessungsseiten

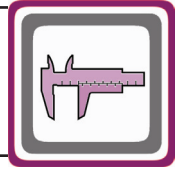

-Mil ucu çektirme deliği DIN 332 sayfa 2 / Tapped center hole to DIN 332, sheet 2 / Zentrierung mit Gewinde DIN 332, Blatt 2

KV475.04
KV476.04

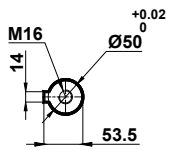
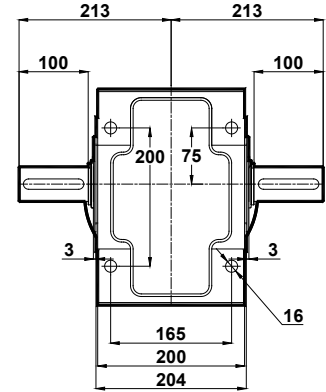
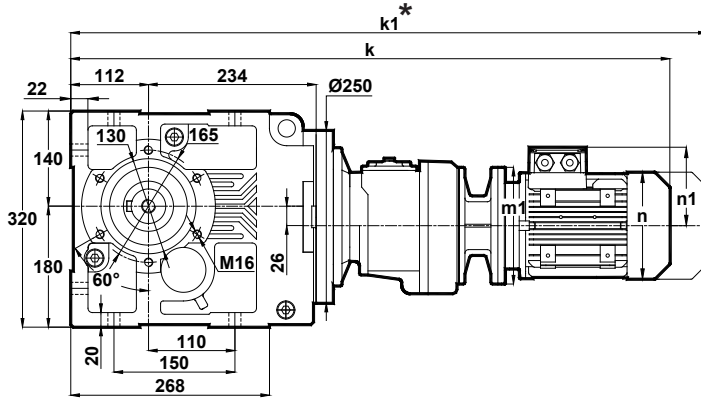

	63/B5	71/B5 71/B14
k	821.5	810.5
k1	882.5	901.5
n / n1	121 / 97	137 / 112
m1 (B5)	140	160
m1 (B14)	-	105

Klemens Pozisyonları
Terminal Box Positions
Klemmenkasten Positionen

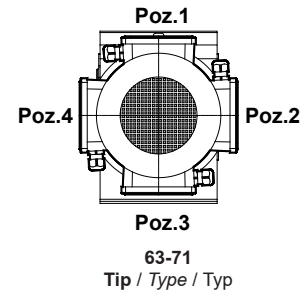

KV475.05
KV476.05

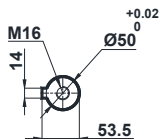
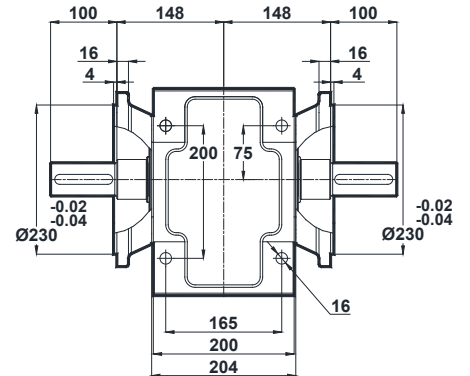
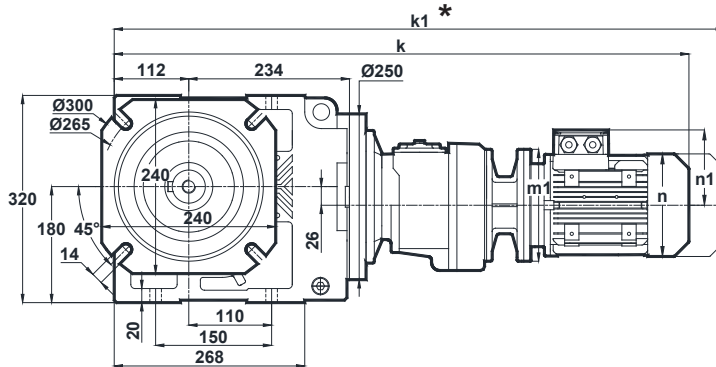

	63/B5	71/B5 71/B14
k	821.5	810.5
k1	882.5	901.5
n / n1	121 / 97	137 / 112
m1 (B5)	140	160
m1 (B14)	-	105

Opsiyonel flanş ölçüleri için sayfa 587'ye bakınız.
Please see on page 587 for optional flange dimensions
Siehe Seite 587 für auswählbare Flanschabmessungen

* " k1 " Ölçüsü frenli redüktörlere aittir.
Dimension " k1 " is for motors with brake.
Maße " k1 " ist für Bremsenmotoren.

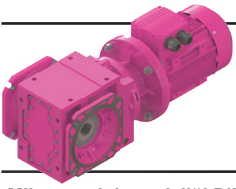

Ölçü Sayfaları Dimension Pages Abmessungsseiten

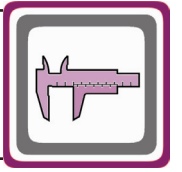

-Mil ucu çekirme deliği DIN 332 sayfa 2 / Tapped center hole to DIN 332, sheet 2 / Zentrierung mit Gewinde DIN 332, Blatt 2

KV475.08
KV476.08

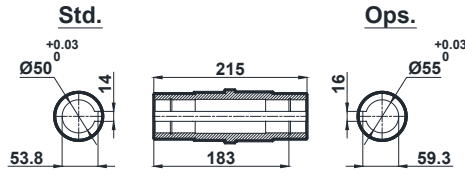
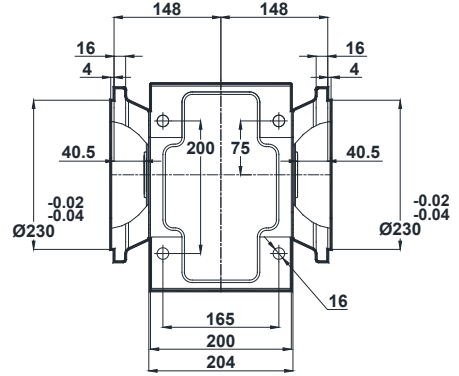
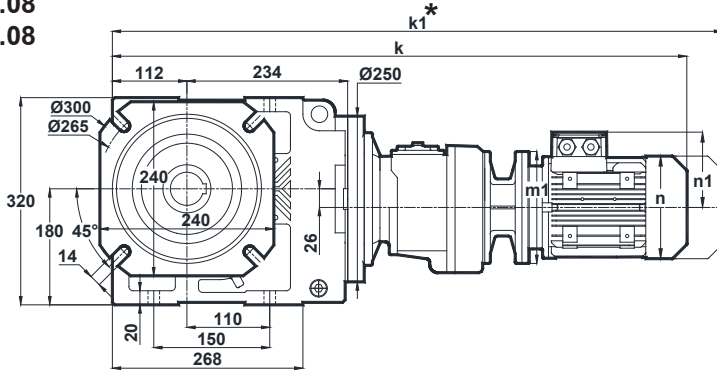

Klemens Pozisyonları
Terminal Box Positions
Klemmenkasten Positionen

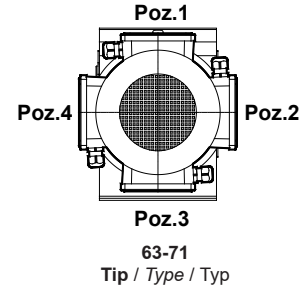

	63/B5	71/B5 71/B14
k	821.5	810.5
k1	882.5	901.5
n / n1	121 / 97	137 / 112
m1 (B5)	140	160
m1 (B14)	-	105

Opsiyonel flanş ölçüleri için sayfa 587'ye bakınız.
Please see on page 587 for optional flange dimensions
Siehe Seite 587 für auswählbare Flanschabmessungen

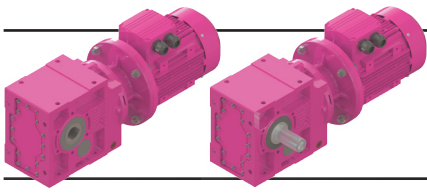

Ölçü Sayfaları

Dimension Pages

Abmessungsseiten

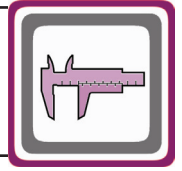

-Mil ucu çektirme deliği DIN 332 sayfa 2 / Tapped center hole to DIN 332, sheet 2 / Zentrierung mit Gewinde DIN 332, Blatt 2

KV573.00

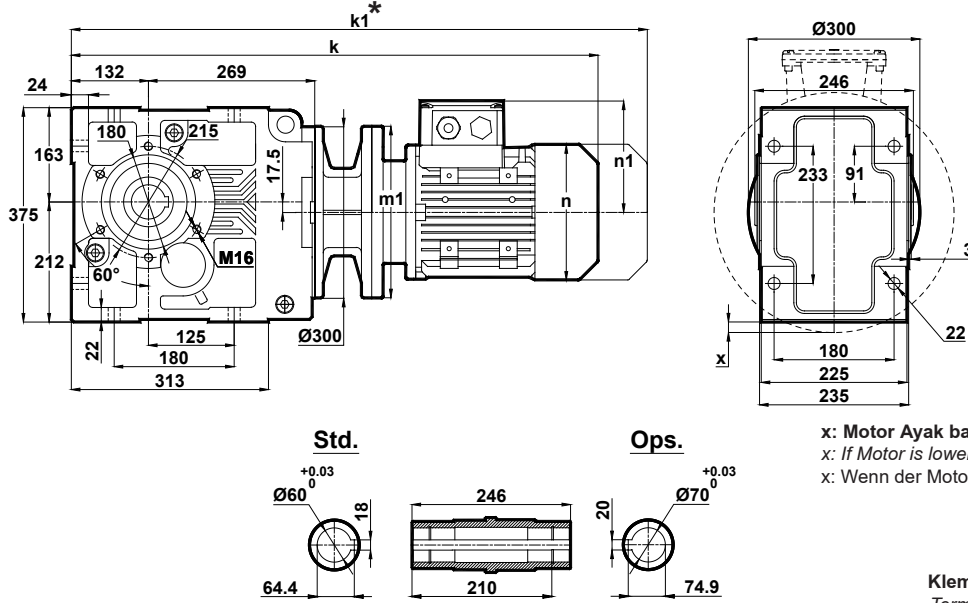

x: Motor Ayak bağlantı yüzeyinin altında ise
x: If Motor is lower than foot mounting plane
x: Wenn der Motor unter der Fußmontageebene ist

Klemens Pozisyonları
Terminal Box Positions
Klemmenkasten Positionen

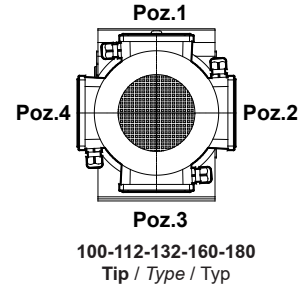

	100L/B5	112M/B5	132S/B5 132S/B14	132M/B5 132M/B14	160M/B5	160L/B5	180M/B5	180L/B5
k	784	804.5	909.5	909.5	1065	1065	1153	1153
k1	892.5	909	1039.5	1039.5	1213	1213	1311.5	1311.5
n / n1	193 / 149	215 / 161	257 / 181	257 / 181	316 / 224	316 / 224	348 / 250	348 / 250
m1 (B5)	250	250	300	300	350	350	350	350
m1 (B14)	-	-	200	200	-	-	-	-
x	-	-	-	-	-	-	-	5,5

KV573.01

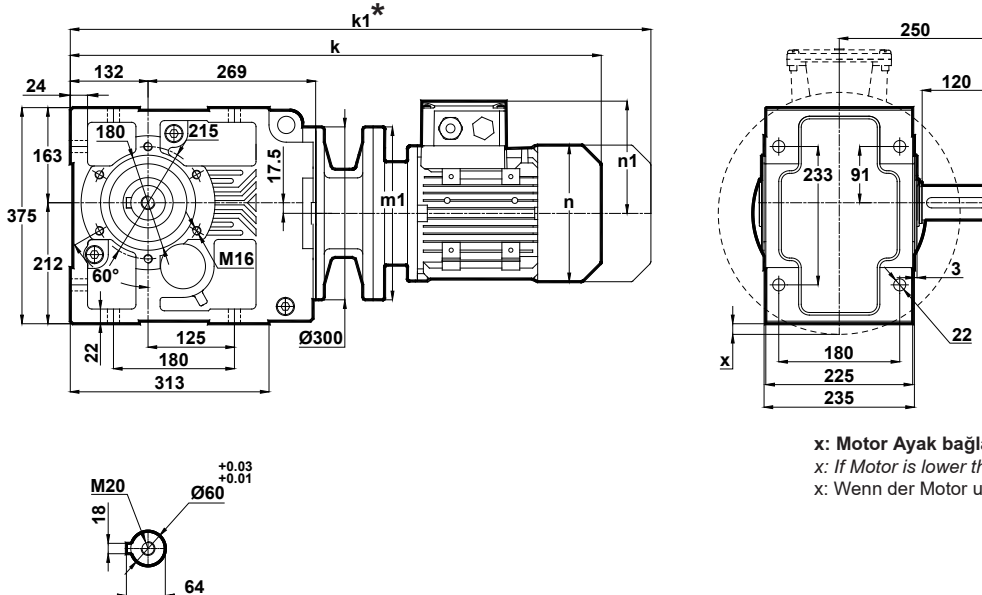

x: Motor Ayak bağlantı yüzeyinin altında ise
x: If Motor is lower than foot mounting plane
x: Wenn der Motor unter der Fußmontageebene ist

	100L/B5	112M/B5	132S/B5 132S/B14	132M/B5 132M/B14	160M/B5	160L/B5	180M/B5	180L/B5
k	784	804.5	909.5	909.5	1065	1065	1153	1153
k1	892.5	909	1039.5	1039.5	1213	1213	1311.5	1311.5
n / n1	193 / 149	215 / 161	257 / 181	257 / 181	316 / 224	316 / 224	348 / 250	348 / 250
m1 (B5)	250	250	300	300	350	350	350	350
m1 (B14)	-	-	200	200	-	-	-	-
x	-	-	-	-	-	-	-	5,5

* " k1 " Ölçüsü frenli redüktörlere aittir.
Dimension " k1 " is for motors with brake.
Maße " k1 " ist für Bremsenmotoren.

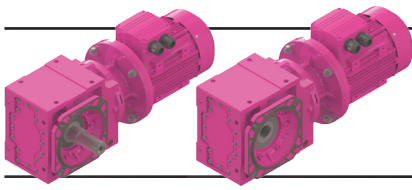

Ölçü Sayfaları Dimension Pages Abmessungsseiten



-Mil ucu çektirme deliği DIN 332 sayfa 2 / Tapped center hole to DIN 332, sheet 2 / Zentrierung mit Gewinde DIN 332, Blatt 2

KV573.02

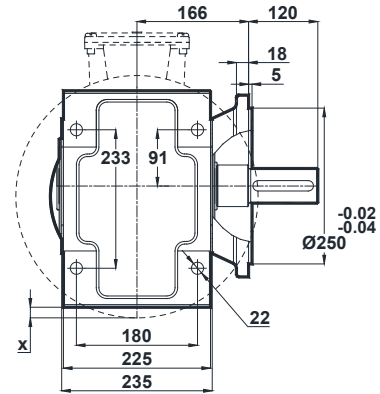
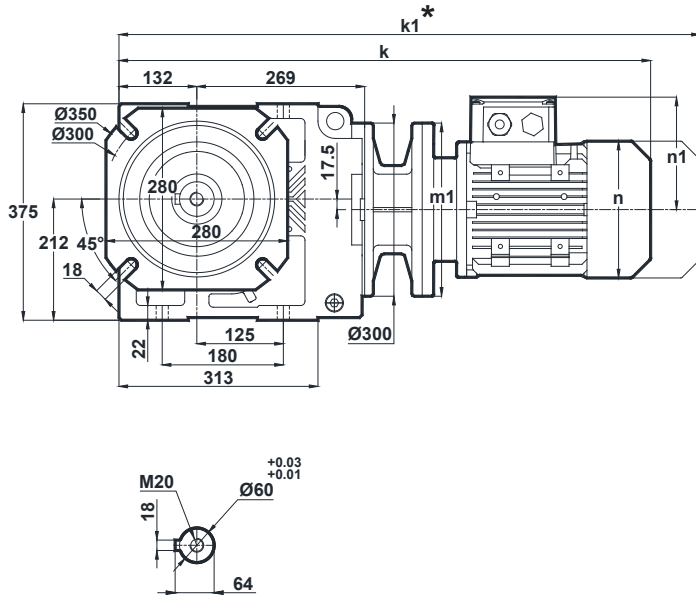

x: Motor Ayak bağlantı yüzeyinin altında ise
x: If Motor is lower than foot mounting plane
x: Wenn der Motor unter der Fußmontageebene ist

Klemens Pozisyonları
Terminal Box Positions
Klemmenkasten Positionen

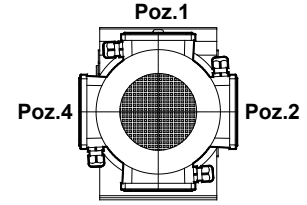

Poz.1
Poz.2
Poz.3
Poz.4
100-112-132-160-180
Tip / Type / Typ

Opsiyonel flanş ölçüleri için sayfa 587'ye bakınız.
Please see on page 587 for optional flange dimensions
Siehe Siete 587 für auswählbare Flanschabmessungen

	100L/B5	112M/B5	132S/B5 132S/B14	132M/B5 132M/B14	160M/B5	160L/B5	180M/B5	180L/B5
k	784	804.5	909.5	909.5	1065	1065	1153	1153
k1	892.5	909	1039.5	1039.5	1213	1213	1311.5	1311.5
n / n1	193 / 149	215 / 161	257 / 181	257 / 181	316 / 224	316 / 224	348 / 250	348 / 250
m1 (B5)	250	250	300	300	350	350	350	350
m1 (B14)	-	-	200	200	-	-	-	-
x	-	-	-	-	-	-	-	5,5

KV573.03

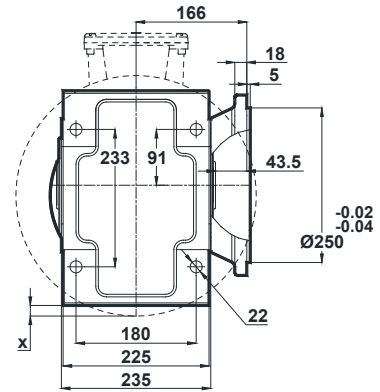
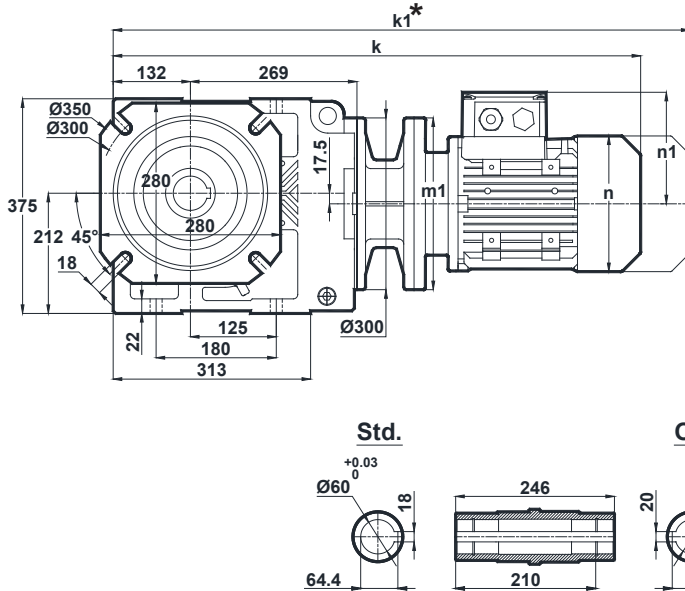

x: Motor Ayak bağlantı yüzeyinin altında ise
x: If Motor is lower than foot mounting plane
x: Wenn der Motor unter der Fußmontageebene ist

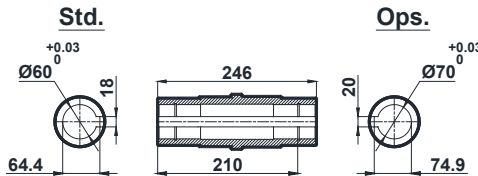

	100L/B5	112M/B5	132S/B5 132S/B14	132M/B5 132M/B14	160M/B5	160L/B5	180M/B5	180L/B5
k	784	804.5	909.5	909.5	1065	1065	1153	1153
k1	892.5	909	1039.5	1039.5	1213	1213	1311.5	1311.5
n / n1	193 / 149	215 / 161	257 / 181	257 / 181	316 / 224	316 / 224	348 / 250	348 / 250
m1 (B5)	250	250	300	300	350	350	350	350
m1 (B14)	-	-	200	200	-	-	-	-
x	-	-	-	-	-	-	-	5,5

Opsiyonel flanş ölçüleri için sayfa 587'ye bakınız.
Please see on page 587 for optional flange dimensions
Siehe Siete 587 für auswählbare Flanschabmessungen

* "k1" Ölçüsü frenli redüktörlere aittir.
Dimension "k1" is for motors with brake.
Maße "k1" ist für Bremsenmotoren.

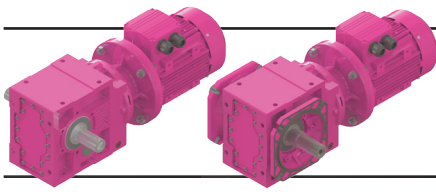

Ölçü Sayfaları

Dimension Pages

Abmessungsseiten

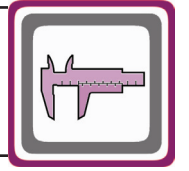

-Mil ucu çekirme deliği DIN 332 sayfa 2 / Tapped center hole to DIN 332, sheet 2 / Zentrierung mit Gewinde DIN 332, Blatt 2

KV573.04

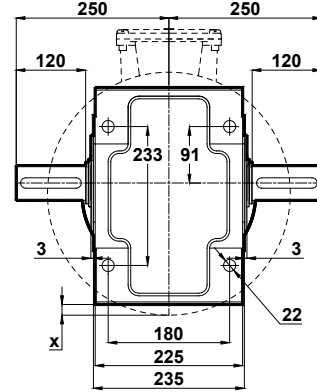
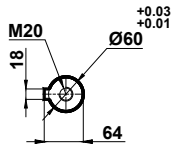
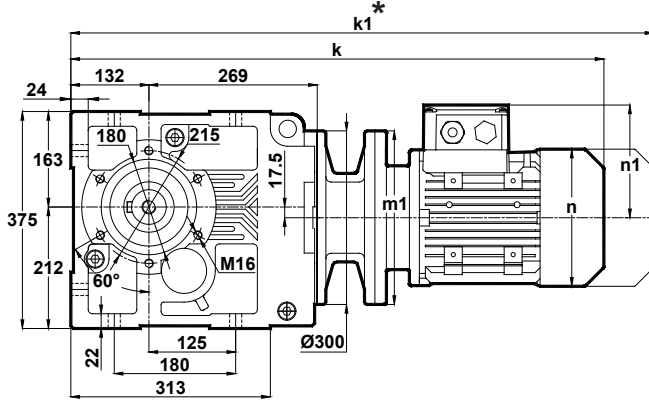

x: Motor ayak bağlantı yüzeyinin altında ise
x: If Motor is lower than foot mounting plane
x: Wenn der Motor unter der Fußmontageebene ist

Klemens Pozisyonları
Terminal Box Positions
Klemmenkasten Positionen

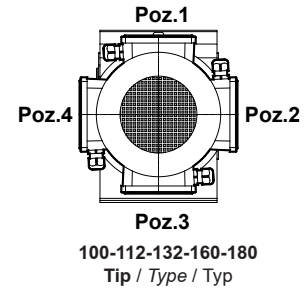

	100L/B5	112M/B5	132S/B5 132S/B14	132M/B5 132M/B14	160M/B5	160L/B5	180M/B5	180L/B5
k	784	804.5	909.5	909.5	1065	1065	1153	1153
k1	892.5	909	1039.5	1039.5	1213	1213	1311.5	1311.5
n / n1	193 / 149	215 / 161	257 / 181	257 / 181	316 / 224	316 / 224	348 / 250	348 / 250
m1 (B5)	250	250	300	300	350	350	350	350
m1 (B14)	-	-	200	200	-	-	-	-
x	-	-	-	-	-	-	-	5,5

KV573.05

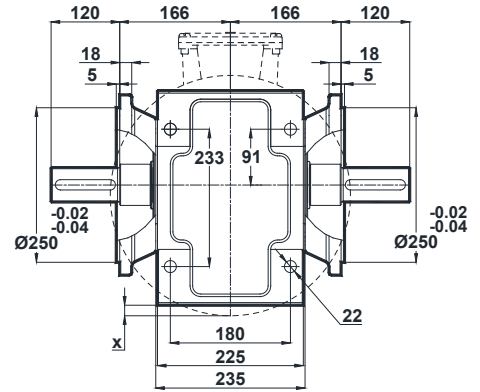
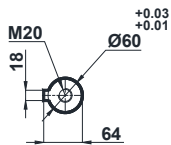
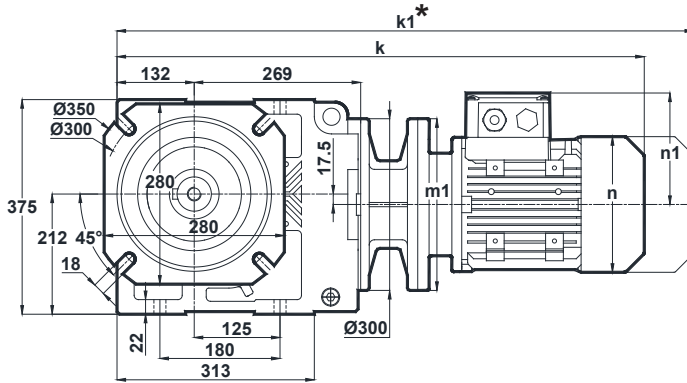

x: Motor ayak bağlantı yüzeyinin altında ise
x: If Motor is lower than foot mounting plane
x: Wenn der Motor unter der Fußmontageebene ist

Opsiyonel flanş ölçüleri için sayfa 587'ye bakınız.
Please see on page 587 for optional flange dimensions
Siehe Seite 587 für auswählbare Flanschabmessungen

	100L/B5	112M/B5	132S/B5 132S/B14	132M/B5 132M/B14	160M/B5	160L/B5	180M/B5	180L/B5
k	784	804.5	909.5	909.5	1065	1065	1153	1153
k1	892.5	909	1039.5	1039.5	1213	1213	1311.5	1311.5
n / n1	193 / 149	215 / 161	257 / 181	257 / 181	316 / 224	316 / 224	348 / 250	348 / 250
m1 (B5)	250	250	300	300	350	350	350	350
m1 (B14)	-	-	200	200	-	-	-	-
x	-	-	-	-	-	-	-	5,5

* " k1 " Ölçüsü frenli redüktörlere aittir.
Dimension " k1 " is for motors with brake.
Maße " k1 " ist für Bremsenmotoren.

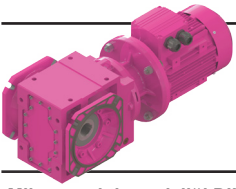

Ölçü Sayfaları Dimension Pages Abmessungsseiten



-Mil ucu çektirme deliği DIN 332 sayfa 2 / Tapped center hole to DIN 332, sheet 2 / Zentrierung mit Gewinde DIN 332, Blatt 2

KV573.08

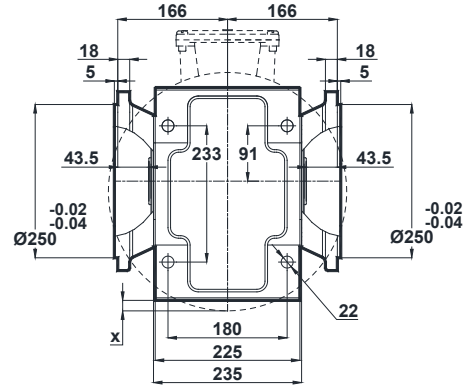
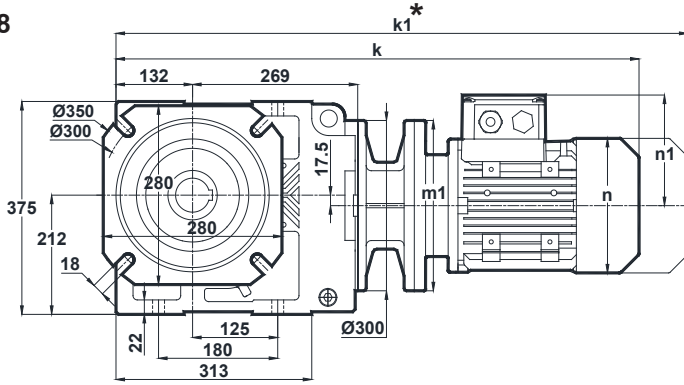

Std.

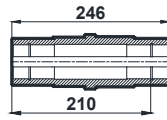
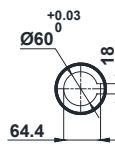

Ops.

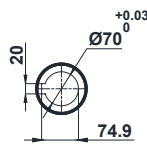

x: Motor Ayak bağlantı yüzeyinin altında ise
x: If Motor is lower than foot mounting plane
x: Wenn der Motor unter der Fußmontageebene ist

Klemens Pozisyonları
Terminal Box Positions
Klemmenkasten Positionen

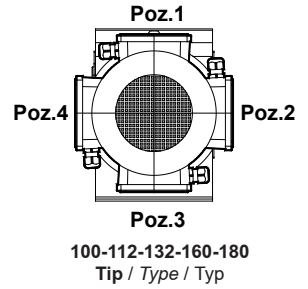

	100L/B5	112M/B5	132S/B5 132S/B14	132M/B5 132M/B14	160M/B5	160L/B5	180M/B5	180L/B5
k	784	804.5	909.5	909.5	1065	1065	1153	1153
k1	892.5	909	1039.5	1039.5	1213	1213	1311.5	1311.5
n / n1	193 / 149	215 / 161	257 / 181	257 / 181	316 / 224	316 / 224	348 / 250	348 / 250
m1 (B5)	250	250	300	300	350	350	350	350
m1 (B14)	-	-	200	200	-	-	-	-
x	-	-	-	-	-	-	-	5,5

Opsiyonel flanş ölçüleri için sayfa 587'ye bakınız.
Please see on page 587 for optional flange dimensions
Siehe Seite 587 für auswählbare Flanschabmessungen

* " k1 " Ölçüsü frenli redüktörlere aittir.
Dimension " k1 " is for motors with brake.
Maße " k1 " ist für Bremsenmotoren.

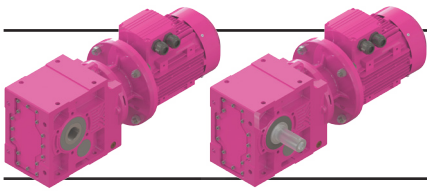

Ölçü Sayfaları Dimension Pages Abmessungsseiten

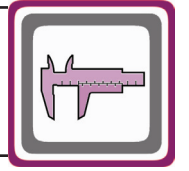

-Mil ucu çektirme deliği DIN 332 sayfa 2 / Tapped center hole to DIN 332, sheet 2 / Zentrierung mit Gewinde DIN 332, Blatt 2

KV574.00

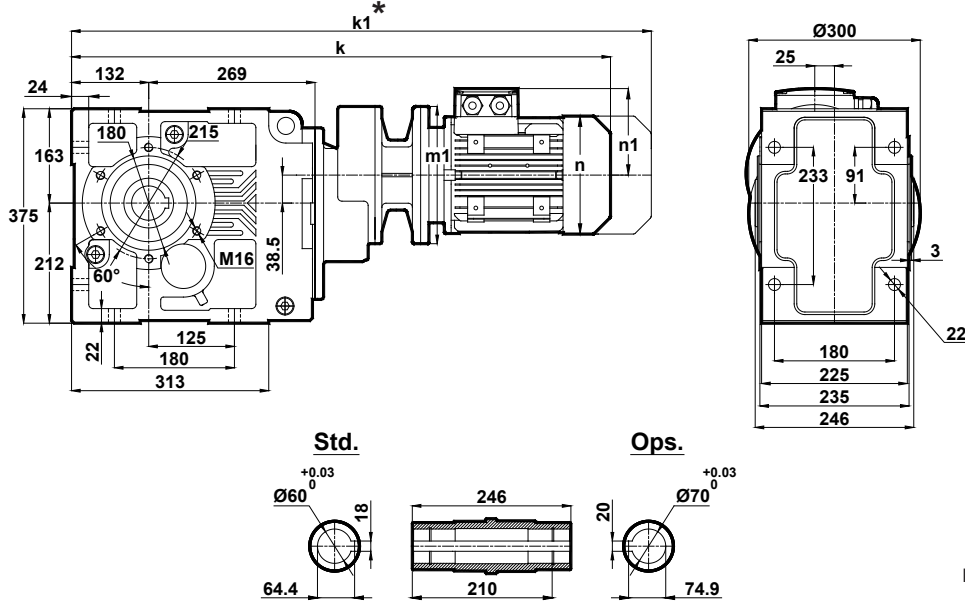

	71/B5	80/B5 80/B14	90S/B5 90S/B14	90L/B5 90L/B14	100L/B5
k	764.5	787.5	828.5	828.5	881
k1	855.5	880.5	932	932	989.5
n / n1	137 / 112	155 / 123	176 / 132	176 / 132	193 / 149
m1 (B5)	160	200	200	200	250
m1 (B14)	-	120	140	140	-

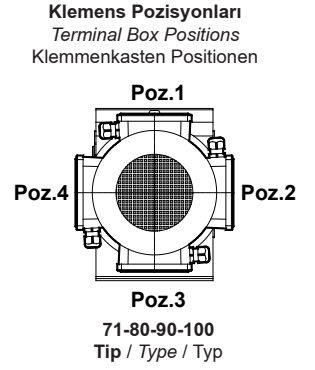

KV574.01

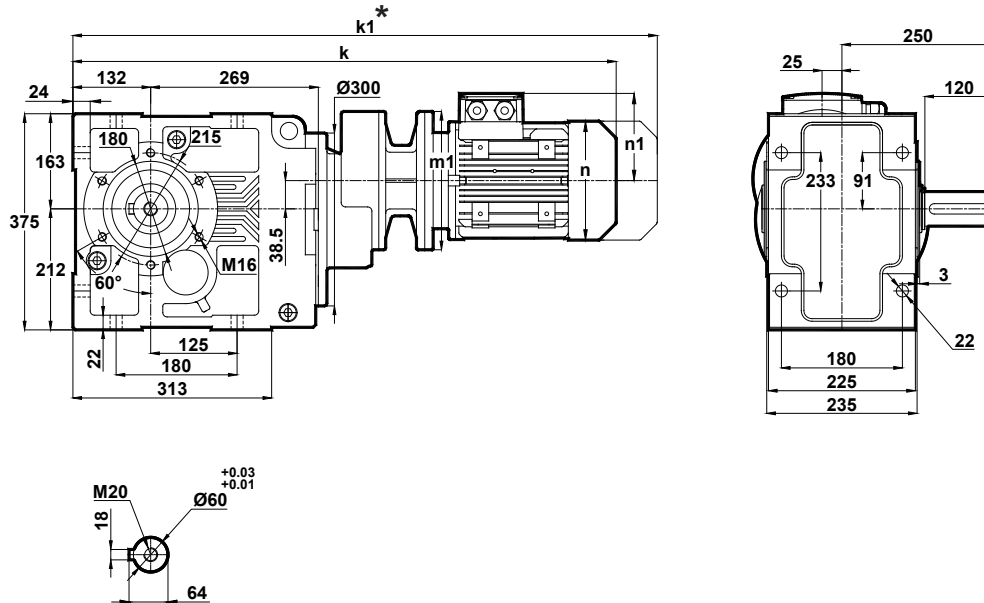

	71/B5	80/B5 80/B14	90S/B5 90S/B14	90L/B5 90L/B14	100L/B5
k	764.5	787.5	828.5	828.5	881
k1	855.5	880.5	932	932	989.5
n / n1	137 / 112	155 / 123	176 / 132	176 / 132	193 / 149
m1 (B5)	160	200	200	200	250
m1 (B14)	-	120	140	140	-

* " k1 " Ölçüsü frenli redüktörlere aittir.
Dimension " k1 " is for motors with brake.
Maße " k1 " ist für Bremsenmotoren.

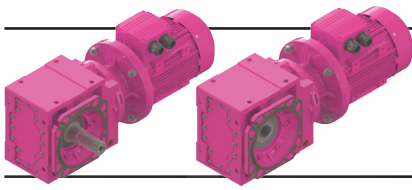

Ölçü Sayfaları

Dimension Pages

Abmessungsseiten

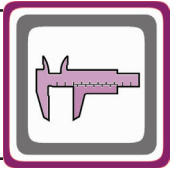

-Mil ucu çektirme deliği DIN 332 sayfa 2 / Tapped center hole to DIN 332, sheet 2 / Zentrierung mit Gewinde DIN 332, Blatt 2

KV574.02

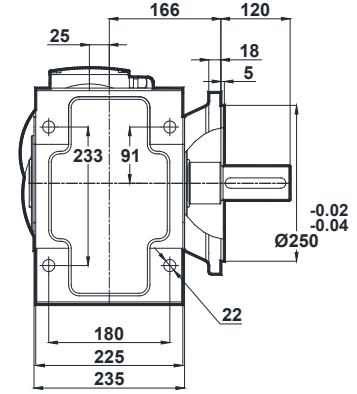
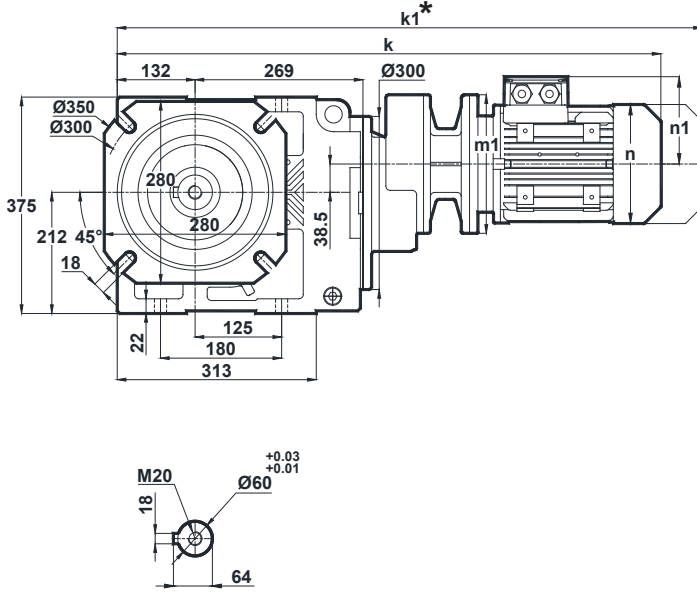

Klemens Pozisyonları
Terminal Box Positions
Klemmenkasten Positionen

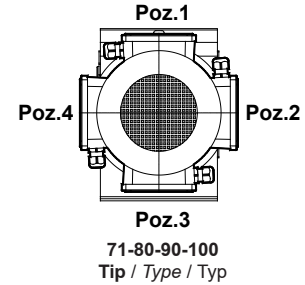

	71/B5	80/B5 80/B14	90S/B5 90S/B14	90L/B5 90L/B14	100L/B5
k	764.5	787.5	828.5	828.5	881
k1	855.5	880.5	932	932	989.5
n / n1	137 / 112	155 / 123	176 / 132	176 / 132	193 / 149
m1 (B5)	160	200	200	200	250
m1 (B14)	-	120	140	140	-

Opsiyonel flanş ölçüleri için sayfa 587'ye bakınız.
Please see on page 587 for optional flange dimensions
Siehe Seite 587 für auswählbare Flanschabmessungen

KV574.03

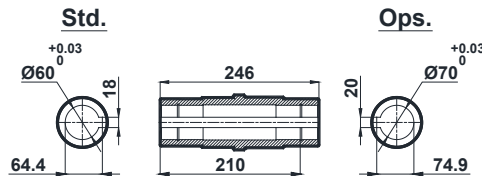
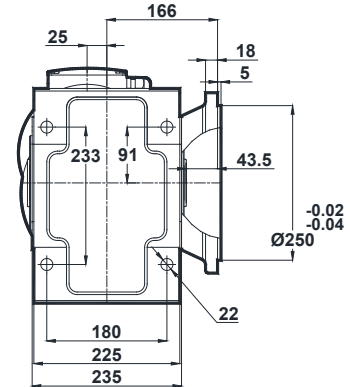
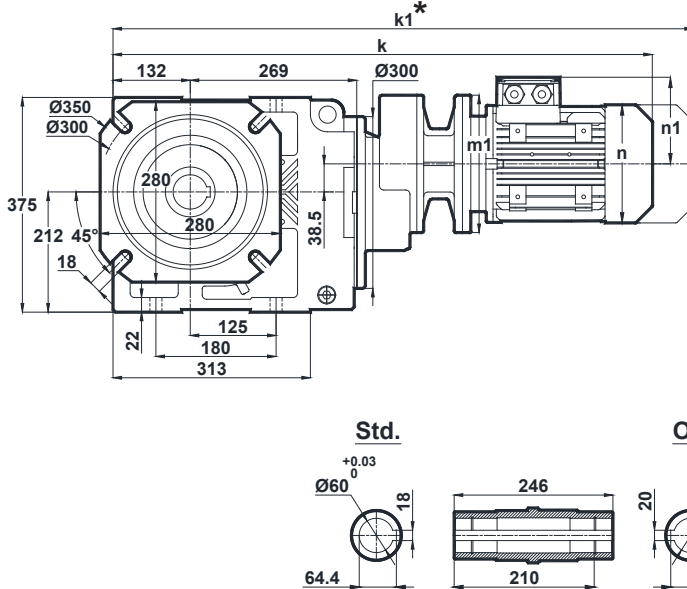

	71/B5	80/B5 80/B14	90S/B5 90S/B14	90L/B5 90L/B14	100L/B5
k	764.5	787.5	828.5	828.5	881
k1	855.5	880.5	932	932	989.5
n / n1	137 / 112	155 / 123	176 / 132	176 / 132	193 / 149
m1 (B5)	160	200	200	200	250
m1 (B14)	-	120	140	140	-

Opsiyonel flanş ölçüleri için sayfa 587'ye bakınız.
Please see on page 587 for optional flange dimensions
Siehe Seite 587 für auswählbare Flanschabmessungen

* " k1 " Ölçüsü frenli redüktörlere aittir.
Dimension " k1 " is for motors with brake.
Maße " k1 " ist für Bremsenmotoren.

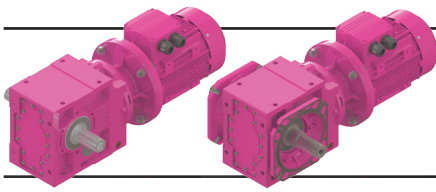

Ölçü Sayfaları

Dimension Pages

Abmessungsseiten

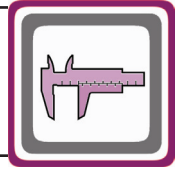

-Mil ucu çektirme deliği DIN 332 sayfa 2 / Tapped center hole to DIN 332, sheet 2 / Zentrierung mit Gewinde DIN 332, Blatt 2

KV574.04

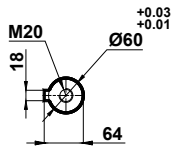
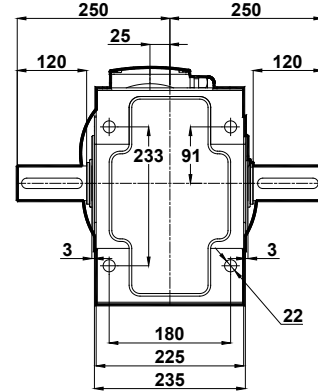
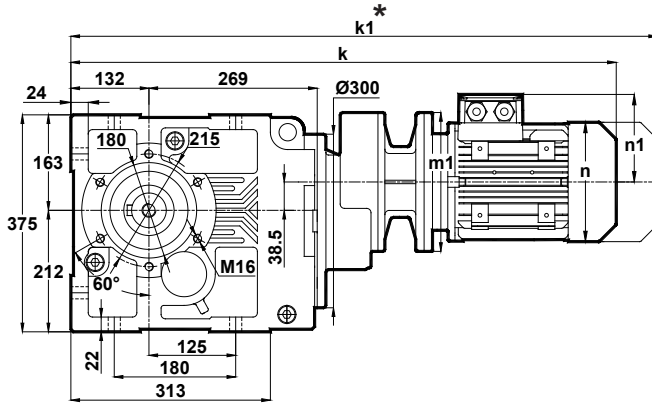

	71/B5	80/B5 80/B14	90S/B5 90S/B14	90L/B5 90L/B14	100L/B5
k	764.5	787.5	828.5	828.5	881
k1	855.5	880.5	932	932	989.5
n / n1	137 / 112	155 / 123	176 / 132	176 / 132	193 / 149
m1 (B5)	160	200	200	200	250
m1 (B14)	-	120	140	140	-

Klemens Pozisyonları
Terminal Box Positions
Klemmenkasten Positionen

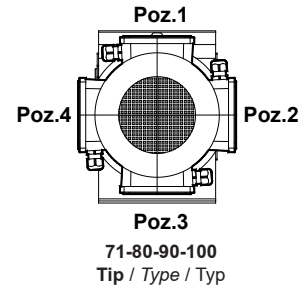

KV574.05

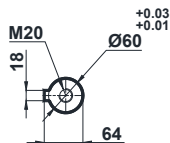
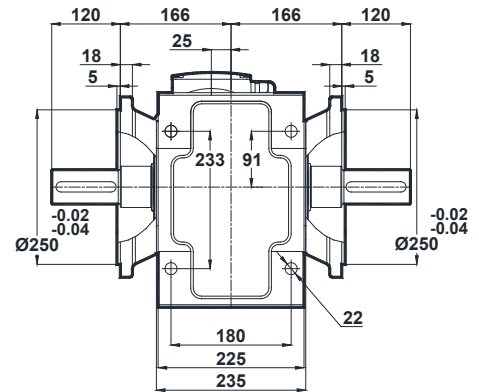
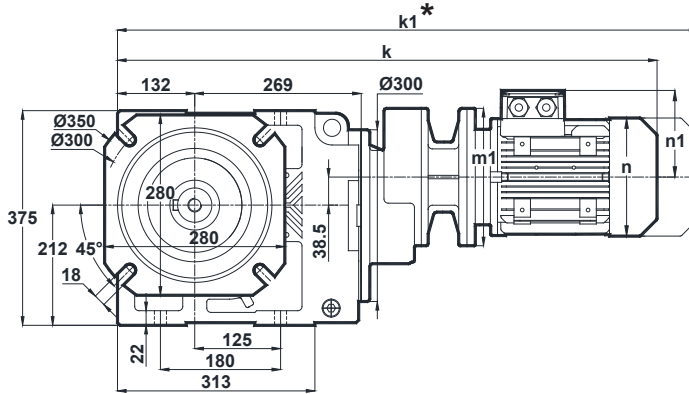

	71/B5	80/B5 80/B14	90S/B5 90S/B14	90L/B5 90L/B14	100L/B5
k	764.5	787.5	828.5	828.5	881
k1	855.5	880.5	932	932	989.5
n / n1	137 / 112	155 / 123	176 / 132	176 / 132	193 / 149
m1 (B5)	160	200	200	200	250
m1 (B14)	-	120	140	140	-

Opsiyonel flanş ölçüleri için sayfa 587'ye bakınız.
Please see on page 587 for optional flange dimensions
Siehe Seite 587 für auswählbare Flanschabmessungen

* " k1 " Ölçüsü frenli redüktörlere aittir.
Dimension " k1 " is for motors with brake.
Maße " k1 " ist für Bremsenmotoren.

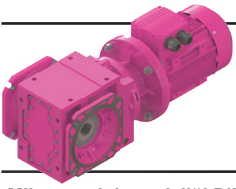

Ölçü Sayfaları Dimension Pages Abmessungsseiten

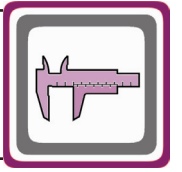

-Mil ucu çektirme deliği DIN 332 sayfa 2 / Tapped center hole to DIN 332, sheet 2 / Zentrierung mit Gewinde DIN 332, Blatt 2

KV574.08

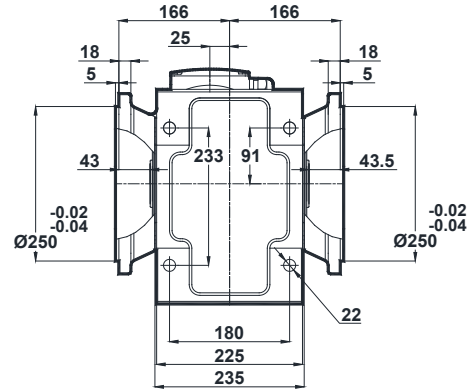
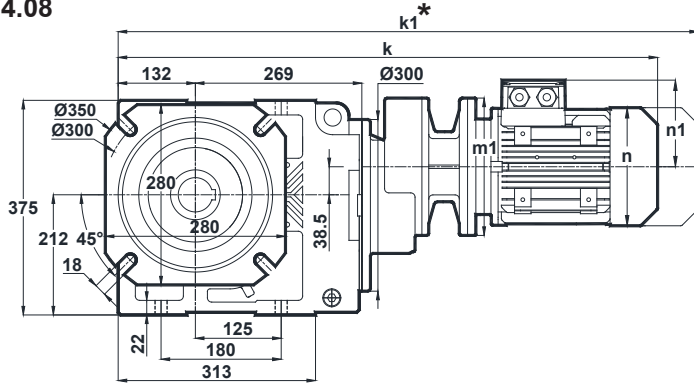

Std.

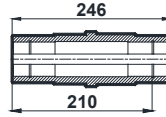
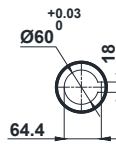

Ops.

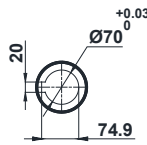

Klemens Pozisyonları
Terminal Box Positions
Klemmenkasten Positionen

Poz.1

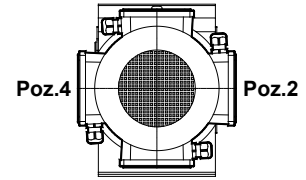

Poz.3

71-80-90-100
Tip / Type / Typ

	71/B5	80/B5 80/B14	90S/B5 90S/B14	90L/B5 90L/B14	100L/B5
k	764.5	787.5	828.5	828.5	881
k1	855.5	880.5	932	932	989.5
n / n1	137 / 112	155 / 123	176 / 132	176 / 132	193 / 149
m1 (B5)	160	200	200	200	250
m1 (B14)	-	120	140	140	-

Opsiyonel flanş ölçüleri için sayfa 587'ye bakınız.
Please see on page 587 for optional flange dimensions
Siehe Seite 587 für auswählbare Flanschabmessungen

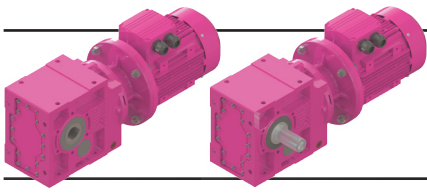

Ölçü Sayfaları

Dimension Pages

Abmessungsseiten

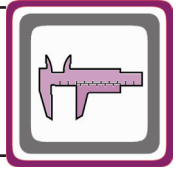

-Mil ucu çektirme deliği DIN 332 sayfa 2 / Tapped center hole to DIN 332, sheet 2 / Zentrierung mit Gewinde DIN 332, Blatt 2

KV575.00
KV576.00

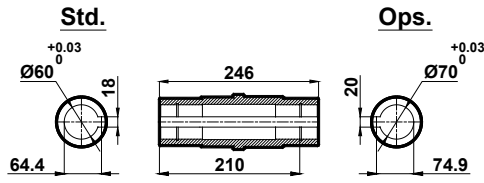
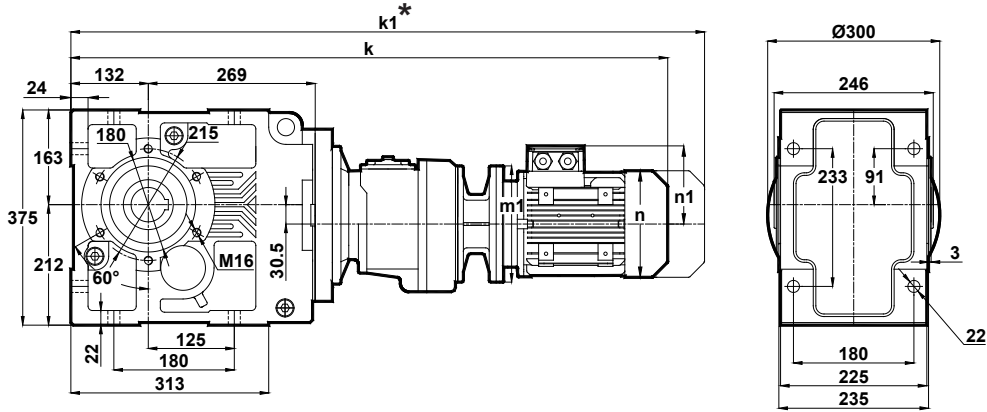

	63/B5	71/B5 71/B14	80/B5 80/B14
k	876.5	865.5	917.5
k1	937.5	956.5	1010.5
n / n1	121 / 97	137 / 112	155 / 123
m1 (B5)	140	160	200
m1 (B14)	-	105	120

Klemens Pozisyonları
Terminal Box Positions
Klemmenkasten Positionen

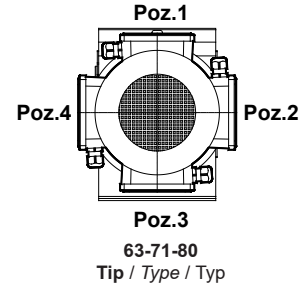

KV575.01
KV576.01

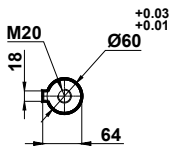
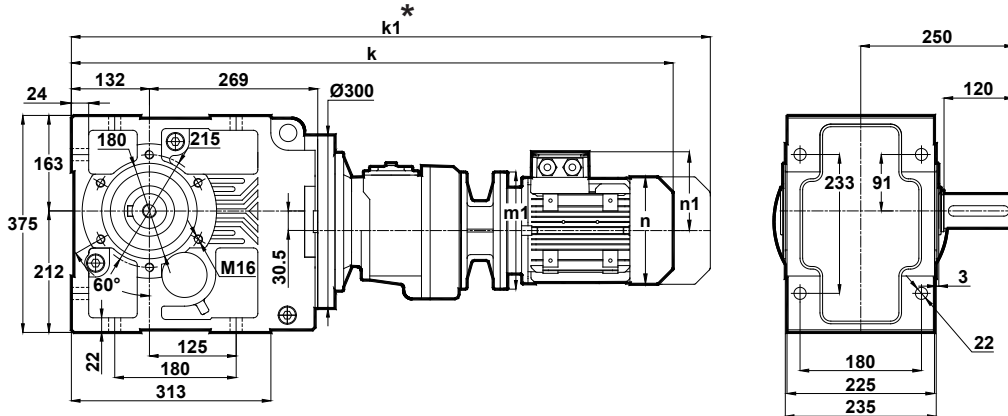

	63/B5	71/B5 71/B14	80/B5 80/B14
k	876.5	865.5	917.5
k1	937.5	956.5	1010.5
n / n1	121 / 97	137 / 112	155 / 123
m1 (B5)	140	160	200
m1 (B14)	-	105	120

* " k1 " Ölçüsü frenli redüktörlere aittir.
Dimension " k1 " is for motors with brake.
Maße " k1 " ist für Bremsenmotoren.

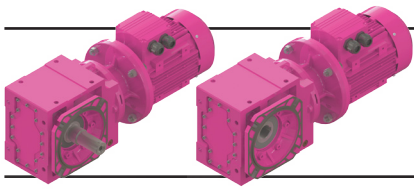

Ölçü Sayfaları

Dimension Pages

Abmessungsseiten



-Mil ucu çekirme deliği DIN 332 sayfa 2 / Tapped center hole to DIN 332, sheet 2 / Zentrierung mit Gewinde DIN 332, Blatt 2

KV575.02
KV576.02

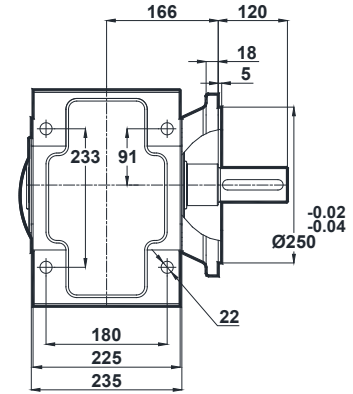
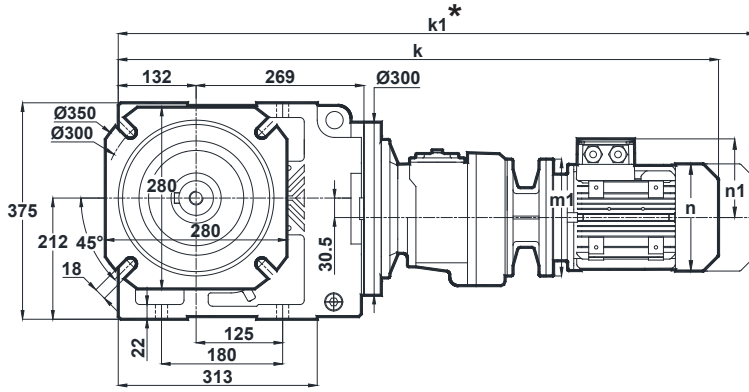

Klemens Pozisyonları
Terminal Box Positions
Klemmenkasten Positionen

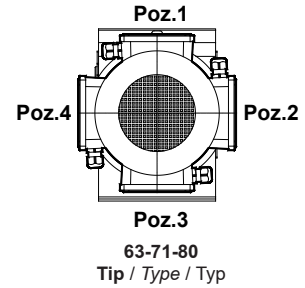

Opsiyonel flanş ölçüleri için sayfa 587'ye bakınız.
Please see on page 587 for optional flange dimensions
Siehe Seite 587 für auswählbare Flanschabmessungen

	63/B5	71/B5 71/B14	80/B5 80/B14
k	876.5	865.5	917.5
k1	937.5	956.5	1010.5
n / n1	121 / 97	137 / 112	155 / 123
m1 (B5)	140	160	200
m1 (B14)	-	105	120

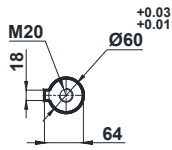

KV575.03
KV576.03

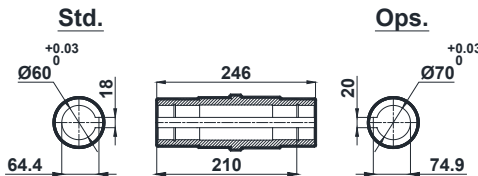
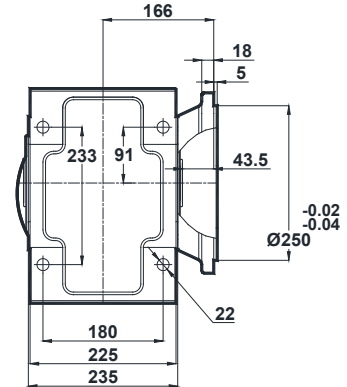
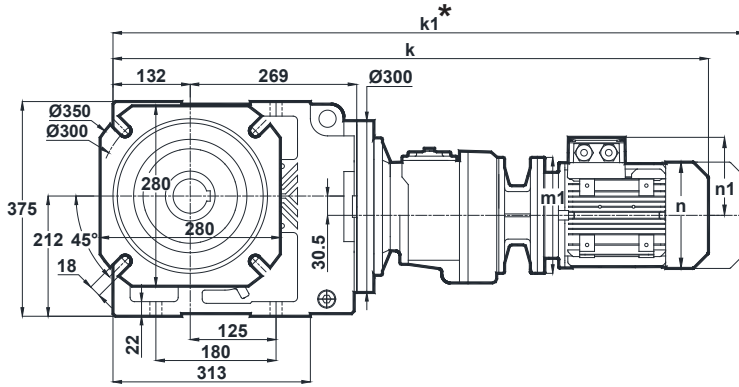

	63/B5	71/B5 71/B14	80/B5 80/B14
k	876.5	865.5	917.5
k1	937.5	956.5	1010.5
n / n1	121 / 97	137 / 112	155 / 123
m1 (B5)	140	160	200
m1 (B14)	-	105	120

Opsiyonel flanş ölçüleri için sayfa 587'ye bakınız.
Please see on page 587 for optional flange dimensions
Siehe Seite 587 für auswählbare Flanschabmessungen

* " k1 " Ölçüsü frenli redüktörlere aittir.
Dimension " k1 " is for motors with brake.
Maße " k1 " ist für Bremsenmotoren.

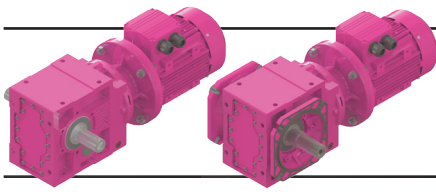

Ölçü Sayfaları

Dimension Pages

Abmessungsseiten

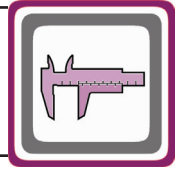

-Mil ucu çektirme deliği DIN 332 sayfa 2 / Tapped center hole to DIN 332, sheet 2 / Zentrierung mit Gewinde DIN 332, Blatt 2

KV575.04
KV576.04

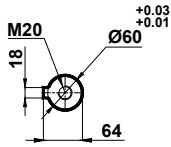
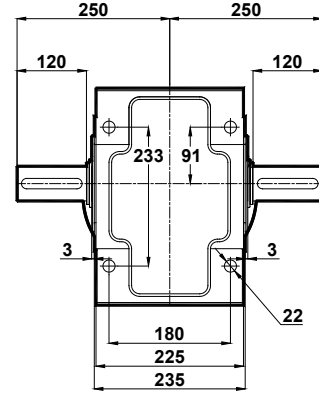
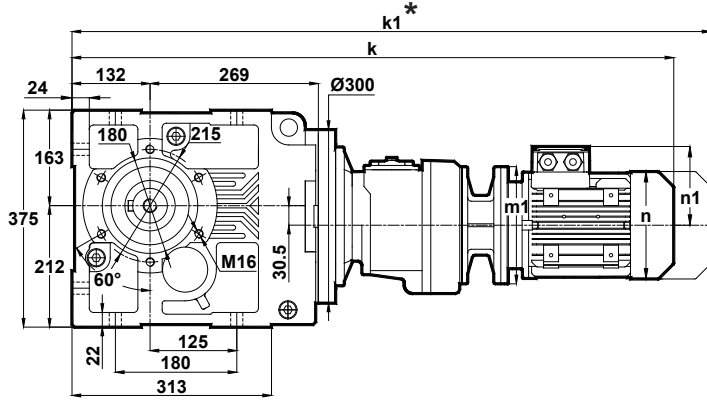

	63/B5	71/B5 71/B14	80/B5 80/B14
k	876.5	865.5	917.5
k1	937.5	956.5	1010.5
n / n1	121 / 97	137 / 112	155 / 123
m1 (B5)	140	160	200
m1 (B14)	-	105	120

Klemens Pozisyonları
Terminal Box Positions
Klemmenkasten Positionen

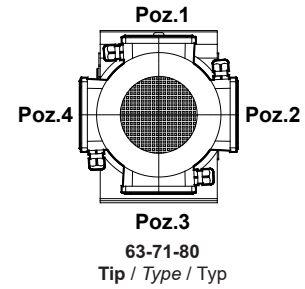

KV575.05
KV576.05

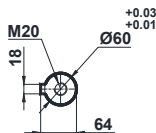
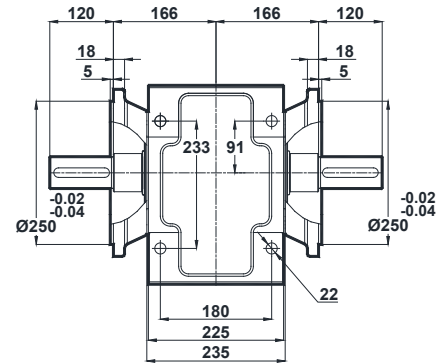
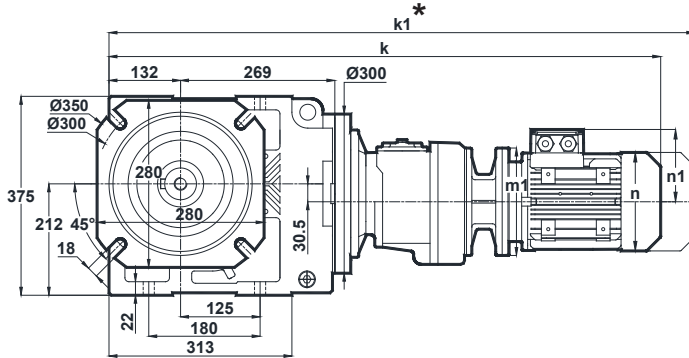

	63/B5	71/B5 71/B14	80/B5 80/B14
k	876.5	865.5	917.5
k1	937.5	956.5	1010.5
n / n1	121 / 97	137 / 112	155 / 123
m1 (B5)	140	160	200
m1 (B14)	-	105	120

Opsiyonel flanş ölçüleri için sayfa 587'ye bakınız.
Please see on page 587 for optional flange dimensions
Siehe Seite 587 für auswählbare Flanschabmessungen

* " k1 " Ölçüsü frenli redüktörlere aittir.
Dimension " k1 " is for motors with brake.
Maße " k1 " ist für Bremsenmotoren.

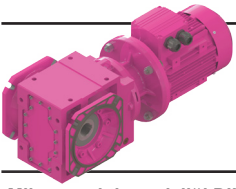

Ölçü Sayfaları Dimension Pages Abmessungsseiten



-Mil ucu çekirme deliği DIN 332 sayfa 2 / Tapped center hole to DIN 332, sheet 2 / Zentrierung mit Gewinde DIN 332, Blatt 2

KV575.08
KV576.08

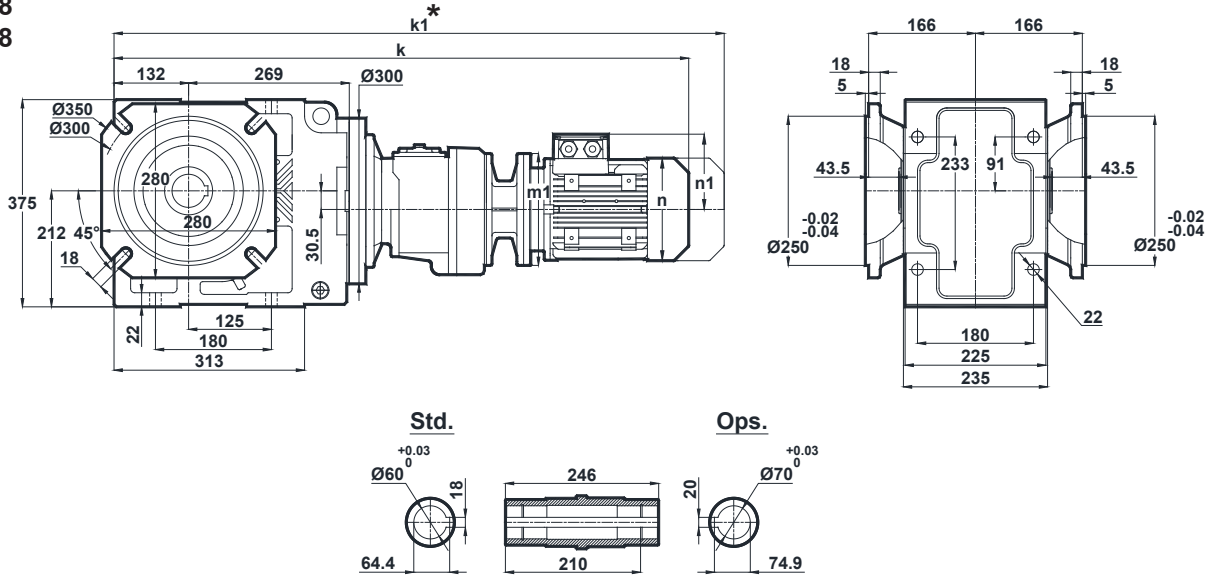

	63/B5	71/B5 71/B14	80/B5 80/B14
k	876.5	865.5	917.5
k1	937.5	956.5	1010.5
n / n1	121 / 97	137 / 112	155 / 123
m1 (B5)	140	160	200
m1 (B14)	-	105	120

Klemens Pozisyonları
Terminal Box Positions
Klemmenkasten Positionen

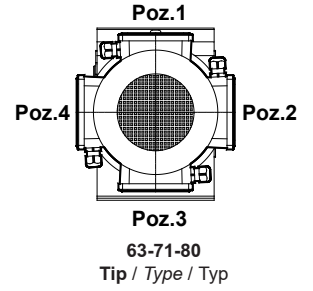

Opsiyonel flanş ölçüleri için sayfa 587'ye bakınız.
Please see on page 587 for optional flange dimensions
Siehe Seite 587 für auswählbare Flanschabmessungen

* "k1" Ölçüsü frenli redüktörlere aittir.
Dimension "k1" is for motors with brake.
Maße "k1" ist für Bremsenmotoren.

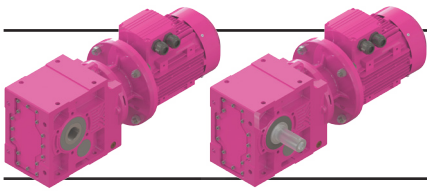

Ölçü Sayfaları

Dimension Pages

Abmessungsseiten

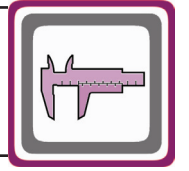

-Mil ucu çektirme deliği DIN 332 sayfa 2 / Tapped center hole to DIN 332, sheet 2 / Zentrierung mit Gewinde DIN 332, Blatt 2

KV673.00

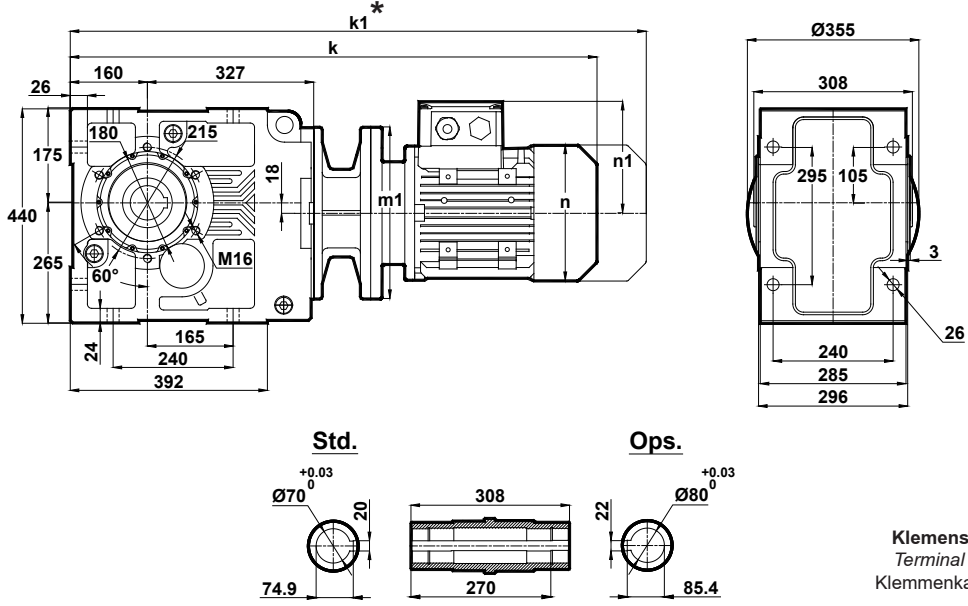

Klemens Pozisyonları
Terminal Box Positions
Klemmenkasten Positionen

Poz.1

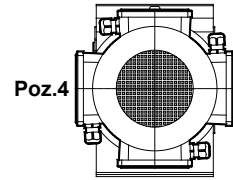

Poz.3

100-112-132-160-180-200-225
Tip / Type / Typ

	100L/B5	112M/B5	132S/B5 132S/B14	132M/B5 132M/B14	160M/B5	160L/B5	180M/B5	180L/B5	200L/B5	225S/B5	225M/B5
k	866	886.5	985.5	985.5	1140.5	1140.5	1228.5	1228.5	1303	1374	1399
k1	974.5	991	1115.5	1115.5	1288.5	1288.5	1387	1387	1489.5	1539	1564
n / n1	193 / 149	215 / 161	257 / 181	257 / 181	316 / 224	316 / 224	348 / 250	348 / 250	396 / 287	438 / 316	438 / 316
m1 (B5)	250	250	300	300	350	350	350	350	400	450	450
m1 (B14)	-	-	200	200	-	-	-	-	-	-	-

KV673.01

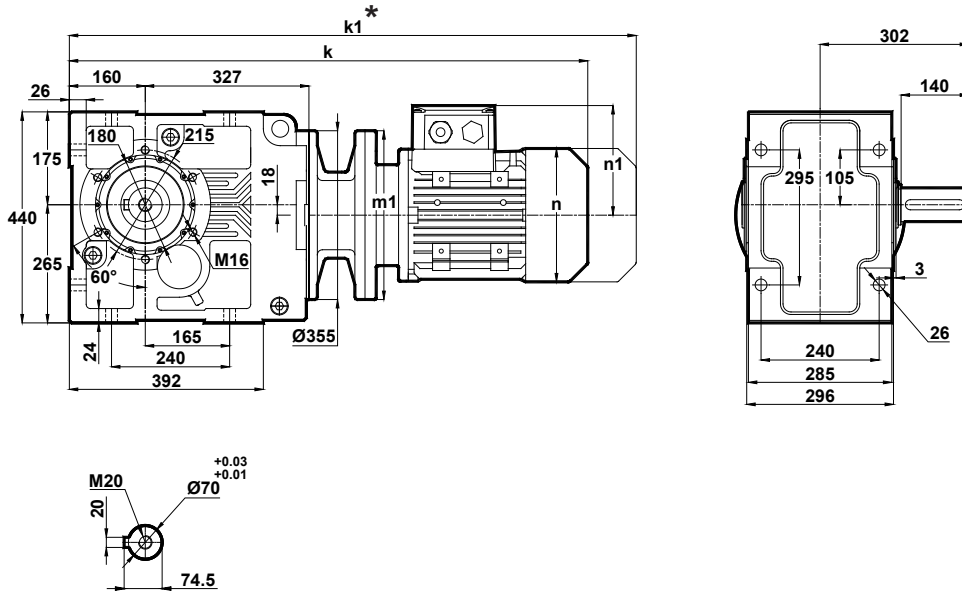

	100L/B5	112M/B5	132S/B5 132S/B14	132M/B5 132M/B14	160M/B5	160L/B5	180M/B5	180L/B5	200L/B5	225S/B5	225M/B5
k	866	886.5	985.5	985.5	1140.5	1140.5	1228.5	1228.5	1303	1374	1399
k1	974.5	991	1115.5	1115.5	1288.5	1288.5	1387	1387	1489.5	1539	1564
n / n1	193 / 149	215 / 161	257 / 181	257 / 181	316 / 224	316 / 224	348 / 250	348 / 250	396 / 287	438 / 316	438 / 316
m1 (B5)	250	250	300	300	350	350	350	350	400	450	450
m1 (B14)	-	-	200	200	-	-	-	-	-	-	-

* " k1 " Ölçüsü frenli redüktörlere aittir.
Dimension " k1 " is for motors with brake.
Maße " k1 " ist für Bremsenmotoren.

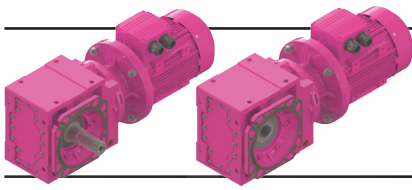

Ölçü Sayfaları

Dimension Pages

Abmessungsseiten

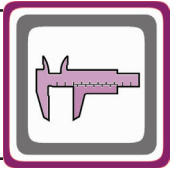

-Mil ucu çektirme deliği DIN 332 sayfa 2 / Tapped center hole to DIN 332, sheet 2 / Zentrierung mit Gewinde DIN 332, Blatt 2

KV673.02

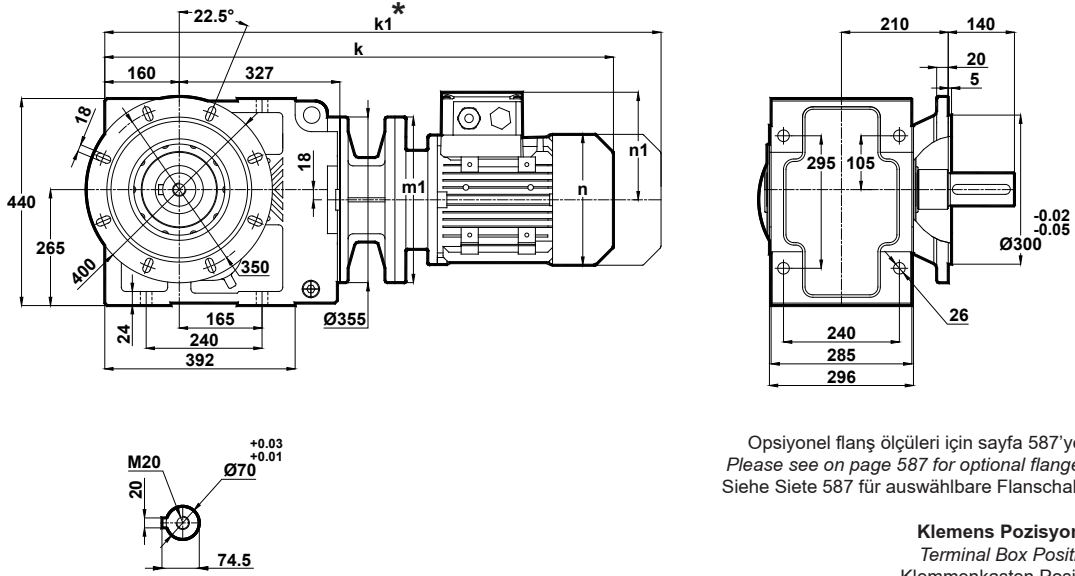

Opsiyonel flanş ölçüleri için sayfa 587'ye bakınız.
Please see on page 587 for optional flange dimensions
Siehe Siete 587 für auswählbare Flanschabmessungen

	100L/B5	112M/B5	132S/B5 132S/B14	132M/B5 132M/B14	160M/B5	160L/B5	180M/B5	180L/B5	200L/B5	225S/B5	225M/B5
k	866	886.5	985.5	985.5	1140.5	1140.5	1228.5	1228.5	1303	1374	1399
k1	974.5	991	1115.5	1115.5	1288.5	1288.5	1387	1387	1489.5	1539	1564
n / n1	193 / 149	215 / 161	257 / 181	257 / 181	316 / 224	316 / 224	348 / 250	348 / 250	396 / 287	438 / 316	438 / 316
m1 (B5)	250	250	300	300	350	350	350	350	400	450	450
m1 (B14)	-	-	200	200	-	-	-	-	-	-	-

Klemens Pozisyonları
Terminal Box Positions
Klemmenkasten Positionen

Poz.1

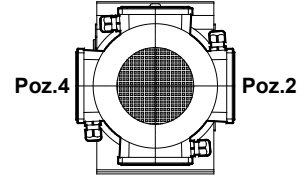

Poz.3

100-112-132-160-180-200-225
Tip / Type / Typ

KV673.03

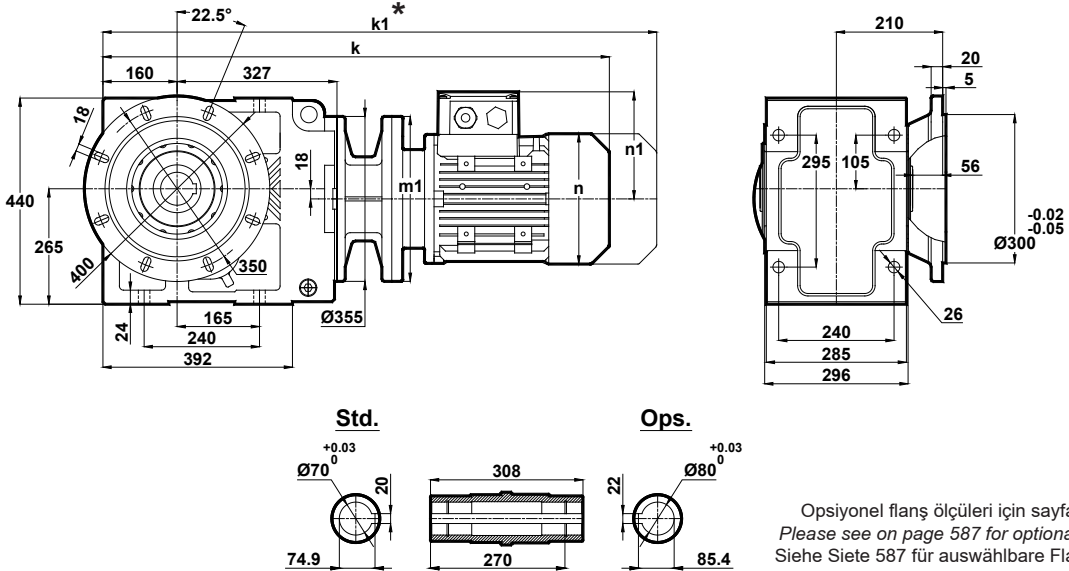

Opsiyonel flanş ölçüleri için sayfa 587'ye bakınız.
Please see on page 587 for optional flange dimensions
Siehe Siete 587 für auswählbare Flanschabmessungen

	100L/B5	112M/B5	132S/B5 132S/B14	132M/B5 132M/B14	160M/B5	160L/B5	180M/B5	180L/B5	200L/B5	225S/B5	225M/B5
k	866	886.5	985.5	985.5	1140.5	1140.5	1228.5	1228.5	1303	1374	1399
k1	974.5	991	1115.5	1115.5	1288.5	1288.5	1387	1387	1489.5	1539	1564
n / n1	193 / 149	215 / 161	257 / 181	257 / 181	316 / 224	316 / 224	348 / 250	348 / 250	396 / 287	438 / 316	438 / 316
m1 (B5)	250	250	300	300	350	350	350	350	400	450	450
m1 (B14)	-	-	200	200	-	-	-	-	-	-	-

* " k1 " Ölçüsü frenli redüktörlere aittir.
Dimension " k1 " is for motors with brake.
Maße " k1 " ist für Bremsenmotoren.

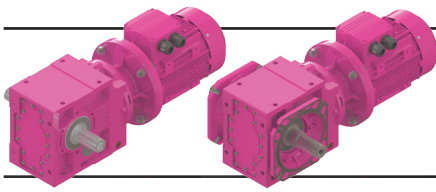

Ölçü Sayfaları Dimension Pages Abmessungenseiten

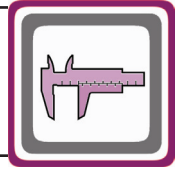

-Mil ucu çektirme deliği DIN 332 sayfa 2 / Tapped center hole to DIN 332, sheet 2 / Zentrierung mit Gewinde DIN 332, Blatt 2

KV673.04

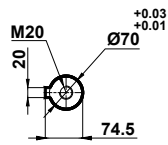
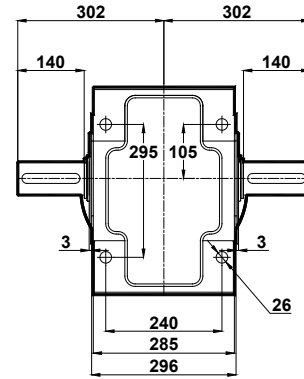
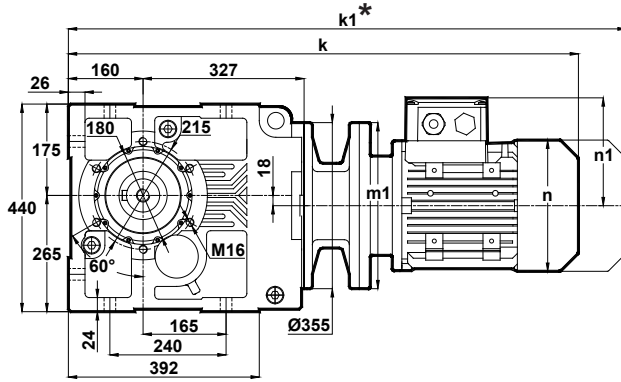

Klemens Pozisyonları
Terminal Box Positions
Klemmenkasten Positionen

	100L/B5	112M/B5	132S/B5 132S/B14	132M/B5 132M/B14	160M/B5	160L/B5	180M/B5	180L/B5	200L/B5	225S/B5	225M/B5
k	866	886.5	985.5	985.5	1140.5	1140.5	1228.5	1228.5	1303	1374	1399
k1	974.5	991	1115.5	1115.5	1288.5	1288.5	1387	1387	1489.5	1539	1564
n / n1	193 / 149	215 / 161	257 / 181	257 / 181	316 / 224	316 / 224	348 / 250	348 / 250	396 / 287	438 / 316	438 / 316
m1 (B5)	250	250	300	300	350	350	350	350	400	450	450
m1 (B14)	-	-	200	200	-	-	-	-	-	-	-

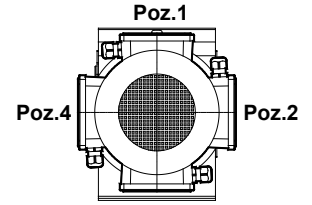

Poz.3
100-112-132-160-180-200-225
Tip / Type / Typ

KV673.05

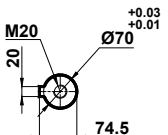
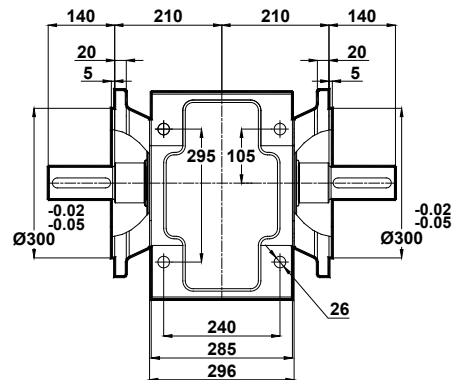
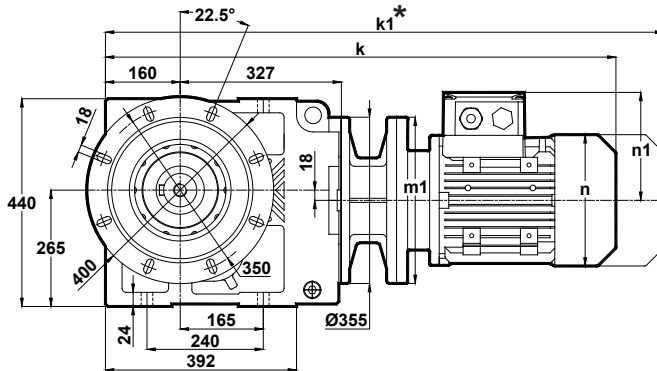

Opsiyonel flanş ölçüleri için sayfa 587'ye bakınız.
Please see on page 587 for optional flange dimensions
Siehe Seite 587 für auswählbare Flanschabmessungen

	100L/B5	112M/B5	132S/B5 132S/B14	132M/B5 132M/B14	160M/B5	160L/B5	180M/B5	180L/B5	200L/B5	225S/B5	225M/B5
k	866	886.5	985.5	985.5	1140.5	1140.5	1228.5	1228.5	1303	1374	1399
k1	974.5	991	1115.5	1115.5	1288.5	1288.5	1387	1387	1489.5	1539	1564
n / n1	193 / 149	215 / 161	257 / 181	257 / 181	316 / 224	316 / 224	348 / 250	348 / 250	396 / 287	438 / 316	438 / 316
m1 (B5)	250	250	300	300	350	350	350	350	400	450	450
m1 (B14)	-	-	200	200	-	-	-	-	-	-	-

* " k1 " Ölçüsü frenli redüktörlere aittir.
Dimension " k1 " is for motors with brake.
Maße " k1 " ist für Bremsenmotoren.

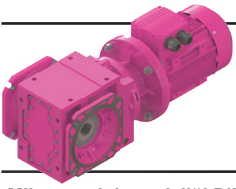

Ölçü Sayfaları Dimension Pages Abmessungenseiten

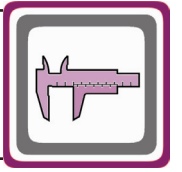

-Mil ucu çektirme deliği DIN 332 sayfa 2 / Tapped center hole to DIN 332, sheet 2 / Zentrierung mit Gewinde DIN 332, Blatt 2

KV673.08

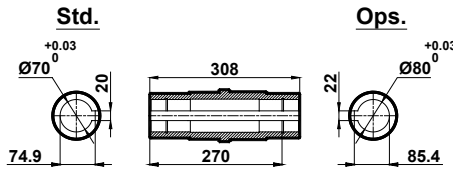
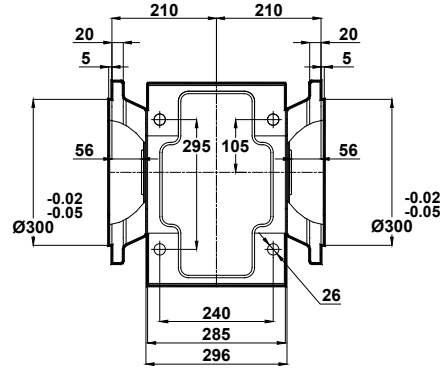
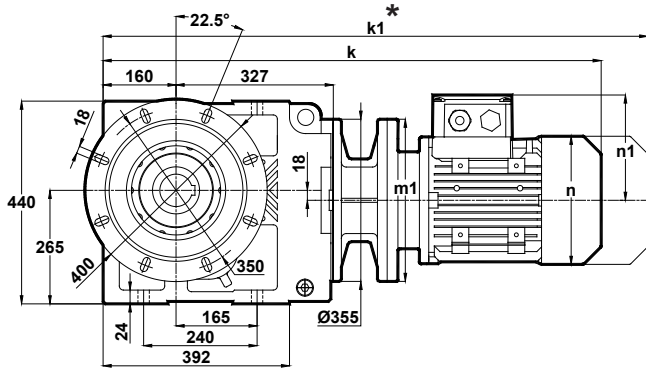

Klemens Pozisyonları
Terminal Box Positions
Klemmenkasten Positionen

	100L/B5	112M/B5	132S/B5 132S/B14	132M/B5 132M/B14	160M/B5	160L/B5	180M/B5	180L/B5	200L/B5	225S/B5	225M/B5
k	866	886.5	985.5	985.5	1140.5	1140.5	1228.5	1228.5	1303	1374	1399
k1	974.5	991	1115.5	1115.5	1288.5	1288.5	1387	1387	1489.5	1539	1564
n / n1	193 / 149	215 / 161	257 / 181	257 / 181	316 / 224	316 / 224	348 / 250	348 / 250	396 / 287	438 / 316	438 / 316
m1 (B5)	250	250	300	300	350	350	350	350	400	450	450
m1 (B14)	-	-	200	200	-	-	-	-	-	-	-

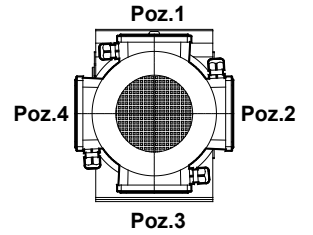

100-112-132-160-180-200-225
Tip / Type / Typ

Opsiyonel flanş ölçüleri için sayfa 587'ye bakınız.
Please see on page 587 for optional flange dimensions
Siehe Seite 587 für auswählbare Flanschabmessungen

* "k1" Ölçüsü frenli redüktörlere aittir.
Dimension "k1" is for motors with brake.
Maße "k1" ist für Bremsenmotoren.

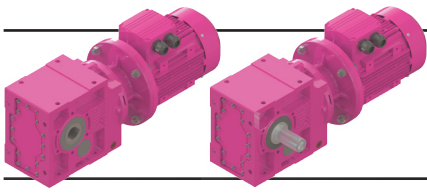

Ölçü Sayfaları

Dimension Pages

Abmessungsseiten

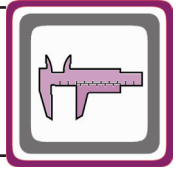

-Mil ucu çektirme deliği DIN 332 sayfa 2 / Tapped center hole to DIN 332, sheet 2 / Zentrierung mit Gewinde DIN 332, Blatt 2

KV674.00

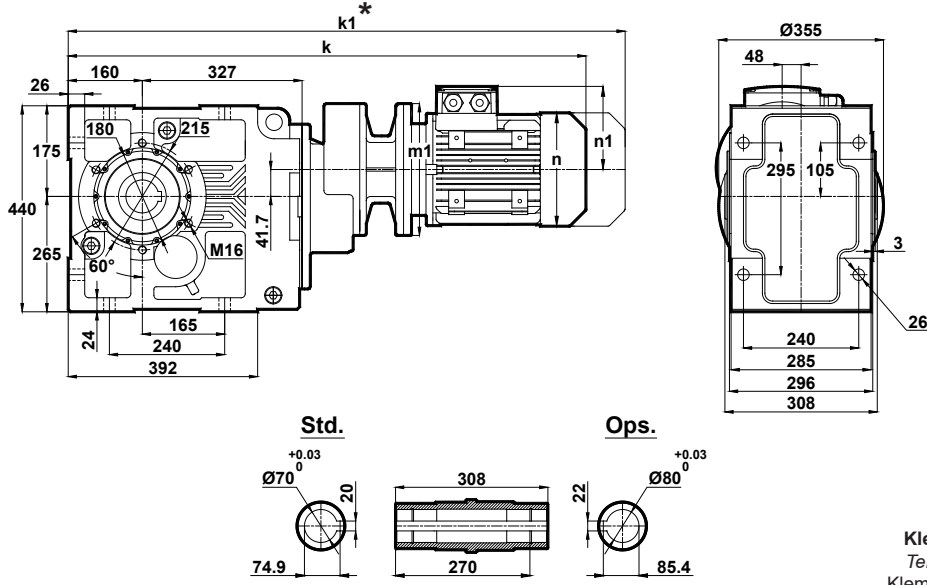

Klemens Pozisyonları
Terminal Box Positions
Klemmenkasten Positionen

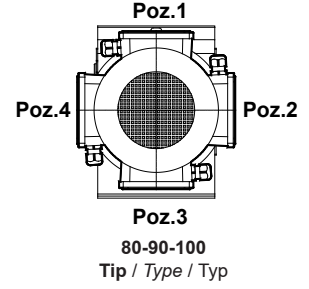

	80/B5	90S/B5 90S/B14	90L/B5 90L/B14	100L/B5 100L/B14
k	879.5	920.5	920.5	974.5
k1	972.5	1024	1024	1083
n / n1	155 / 123	176 / 132	176 / 132	193 / 149
m1 (B5)	200	200	200	250
m1 (B14)	-	140	140	160

KV674.01

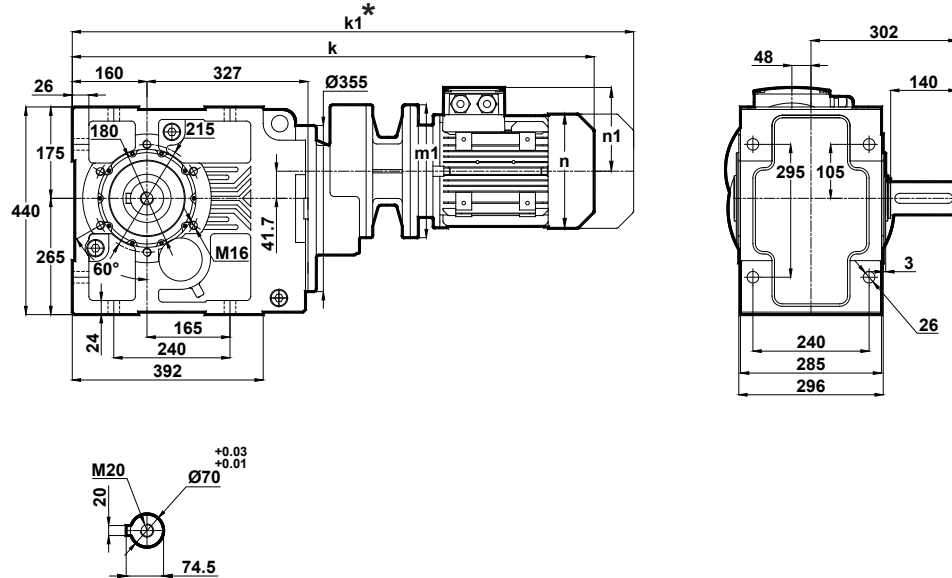

	80/B5	90S/B5 90S/B14	90L/B5 90L/B14	100L/B5 100L/B14
k	879.5	920.5	920.5	974.5
k1	972.5	1024	1024	1083
n / n1	155 / 123	176 / 132	176 / 132	193 / 149
m1 (B5)	200	200	200	250
m1 (B14)	-	140	140	160

* " k1 " Ölçüsü frenli redüktörlere aittir.
Dimension " k1 " is for motors with brake.
Maße " k1 " ist für Bremsenmotoren.

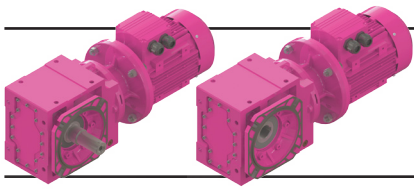

Ölçü Sayfaları

Dimension Pages

Abmessungsseiten



-Mil ucu çektirme deliği DIN 332 sayfa 2 / Tapped center hole to DIN 332, sheet 2 / Zentrierung mit Gewinde DIN 332, Blatt 2

KV674.02

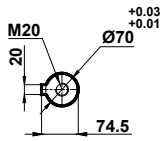
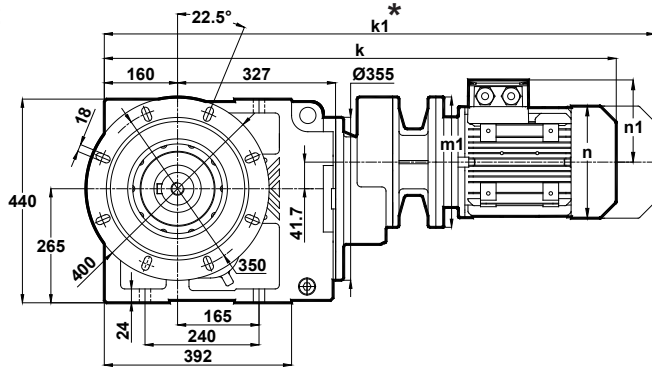

Klemens Pozisyonları
Terminal Box Positions
Klemmenkasten Positionen

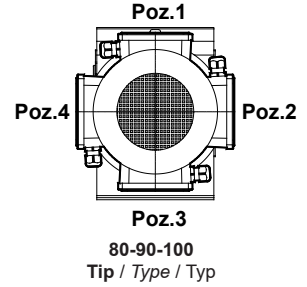

	80/B5	90S/B5 90S/B14	90L/B5 90L/B14	100L/B5 100L/B14
k	879.5	920.5	920.5	974.5
k1	972.5	1024	1024	1083
n / n1	155 / 123	176 / 132	176 / 132	193 / 149
m1 (B5)	200	200	200	250
m1 (B14)	-	140	140	160

Opsiyonel flanş ölçüleri için sayfa 587'ye bakınız.
Please see on page 587 for optional flange dimensions
Siehe Seite 587 für auswählbare Flanschabmessungen

KV674.03

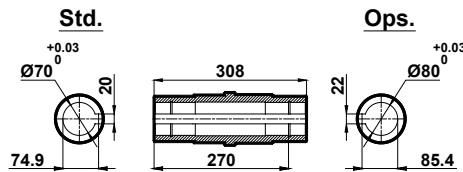
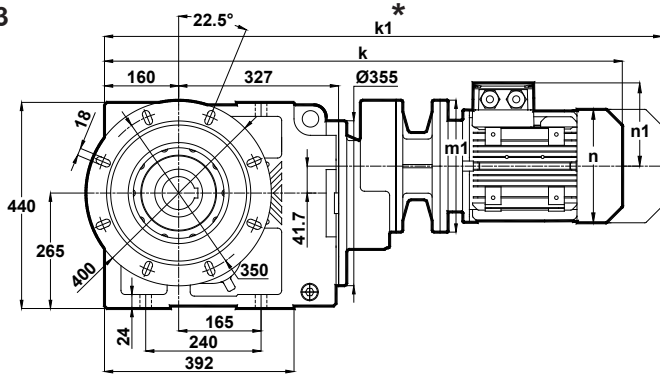

	80/B5	90S/B5 90S/B14	90L/B5 90L/B14	100L/B5 100L/B14
k	879.5	920.5	920.5	974.5
k1	972.5	1024	1024	1083
n / n1	155 / 123	176 / 132	176 / 132	193 / 149
m1 (B5)	200	200	200	250
m1 (B14)	-	140	140	160

Opsiyonel flanş ölçüleri için sayfa 587'ye bakınız.
Please see on page 587 for optional flange dimensions
Siehe Seite 587 für auswählbare Flanschabmessungen

* "k1" Ölçüsü frenli redüktörlere aittir.
Dimension "k1" is for motors with brake.
Maße "k1" ist für Bremsenmotoren.

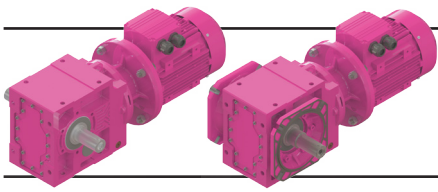

Ölçü Sayfaları

Dimension Pages

Abmessungsseiten

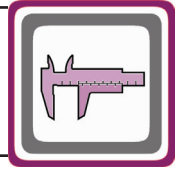

-Mil ucu çektirme deliği DIN 332 sayfa 2 / Tapped center hole to DIN 332, sheet 2 / Zentrierung mit Gewinde DIN 332, Blatt 2

KV674.04

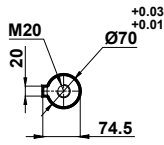
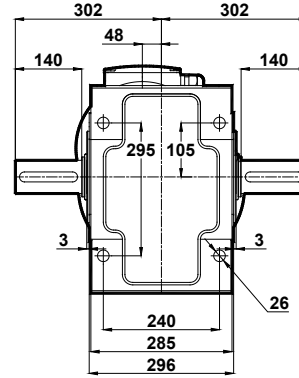
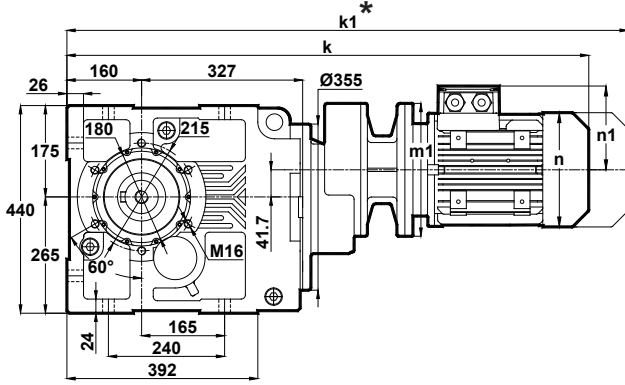

Klemens Pozisyonları
Terminal Box Positions
Klemmenkasten Positionen

	80/B5	90S/B5 90S/B14	90L/B5 90L/B14	100L/B5 100L/B14
k	879.5	920.5	920.5	974.5
k1	972.5	1024	1024	1083
n / n1	155 / 123	176 / 132	176 / 132	193 / 149
m1 (B5)	200	200	200	250
m1 (B14)	-	140	140	160

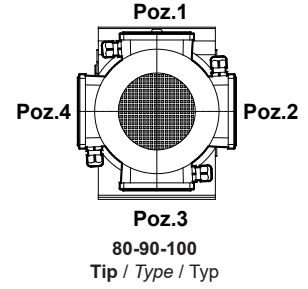

KV674.05

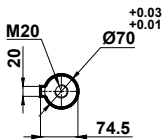
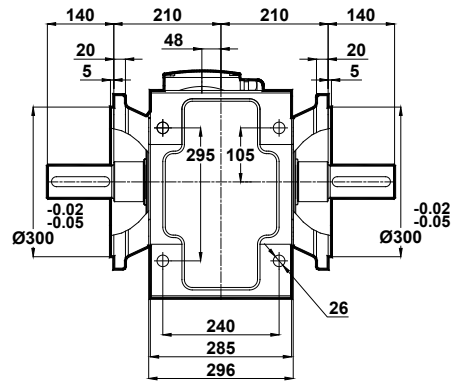
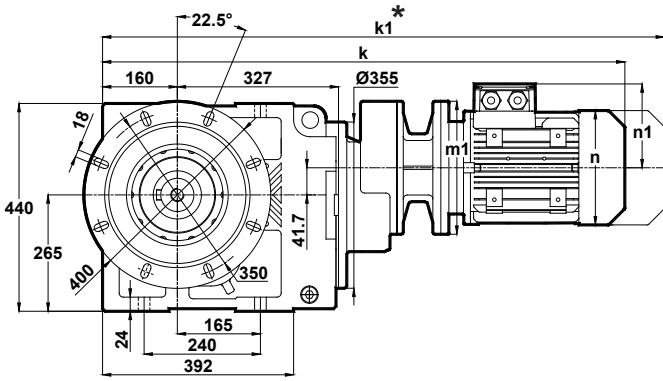

Opsiyonel flanş ölçüleri için sayfa 587'ye bakınız.
Please see on page 587 for optional flange dimensions
Siehe Seite 587 für auswählbare Flanschabmessungen

	80/B5	90S/B5 90S/B14	90L/B5 90L/B14	100L/B5 100L/B14
k	879.5	920.5	920.5	974.5
k1	972.5	1024	1024	1083
n / n1	155 / 123	176 / 132	176 / 132	193 / 149
m1 (B5)	200	200	200	250
m1 (B14)	-	140	140	160

* " k1 " Ölçüsü frenli redüktörlere aittir.
Dimension " k1 " is for motors with brake.
Maße " k1 " ist für Bremsenmotoren.

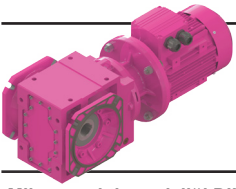

Ölçü Sayfaları Dimension Pages Abmessungenseiten



-Mil ucu çektirme deliği DIN 332 sayfa 2 / Tapped center hole to DIN 332, sheet 2 / Zentrierung mit Gewinde DIN 332, Blatt 2

KV674.08

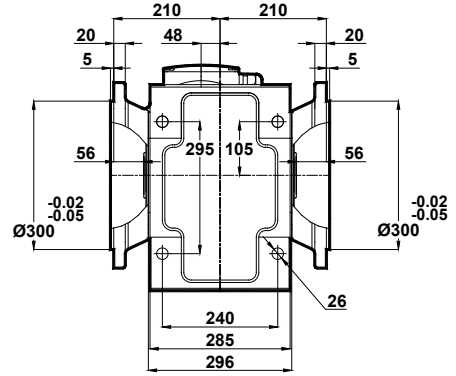
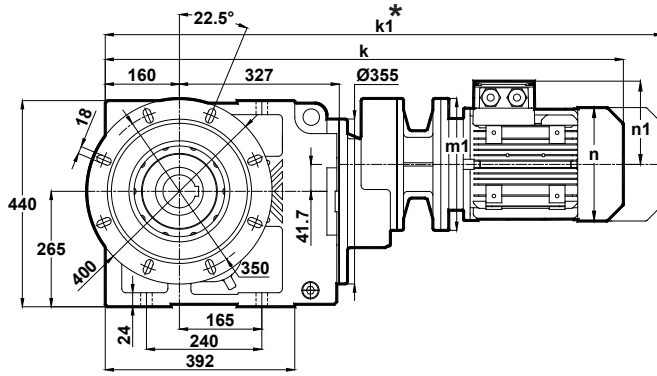

Std.

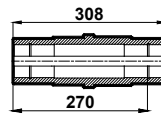
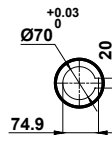

Ops.

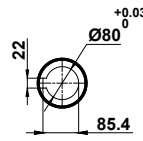

Klemens Pozisyonları
Terminal Box Positions
Klemmenkasten Positionen

	80/B5	90S/B5 90S/B14	90L/B5 90L/B14	100L/B5 100L/B14
k	879.5	920.5	920.5	974.5
k1	972.5	1024	1024	1083
n / n1	155 / 123	176 / 132	176 / 132	193 / 149
m1 (B5)	200	200	200	250
m1 (B14)	-	140	140	160

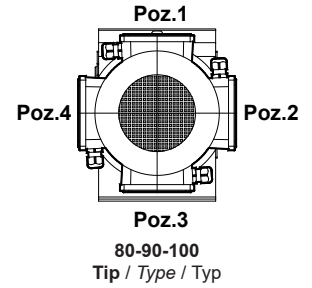

Opsiyonel flanş ölçüleri için sayfa 587'ye bakınız.
Please see on page 587 for optional flange dimensions
Siehe Seite 587 für auswählbare Flanschabmessungen

* "k1" Ölçüsü frenli redüktörlere aittir.
Dimension "k1" is for motors with brake.
Maße "k1" ist für Bremsenmotoren.

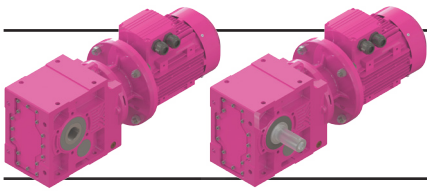

Ölçü Sayfaları

Dimension Pages

Abmessungsseiten

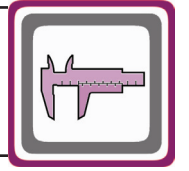

-Mil ucu çektirme deliği DIN 332 sayfa 2 / Tapped center hole to DIN 332, sheet 2 / Zentrierung mit Gewinde DIN 332, Blatt 2

KV675.00
KV676.00

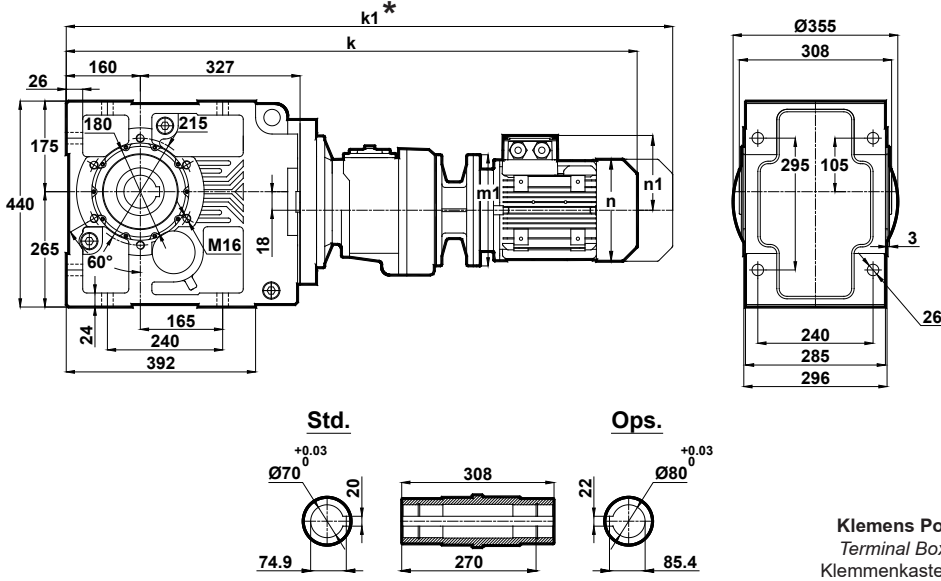

Klemens Pozisyonları
Terminal Box Positions
Klemmenkasten Positionen

	71/B5	80/B5 80/B14	90S/B5 90S/B14	90L/B5 90L/B14
k	1007.5	1030.5	1071.5	1071.5
k1	1098.5	1123.5	1175	1175
n / n1	137 / 112	155 / 123	176 / 132	176 / 132
m1 (B5)	160	200	200	200
m1 (B14)	-	120	140	140

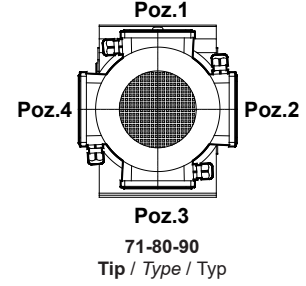

KV675.01
KV676.01

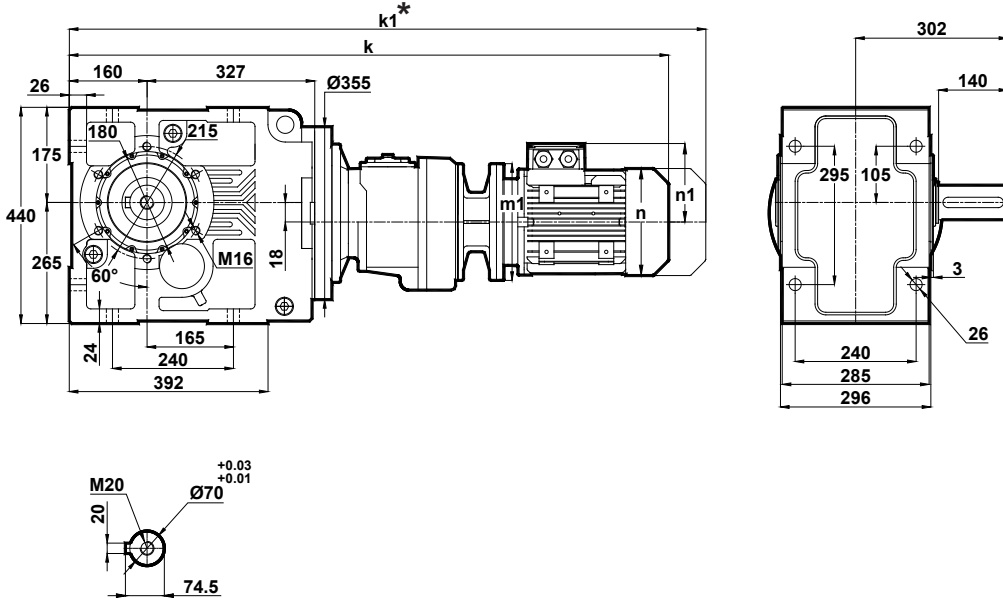

	71/B5	80/B5 80/B14	90S/B5 90S/B14	90L/B5 90L/B14
k	1007.5	1030.5	1071.5	1071.5
k1	1098.5	1123.5	1175	1175
n / n1	137 / 112	155 / 123	176 / 132	176 / 132
m1 (B5)	160	200	200	200
m1 (B14)	-	120	140	140

* " k1 " Ölçüsü frenli redüktörlere aittir.
Dimension " k1 " is for motors with brake.
Maße " k1 " ist für Bremsenmotoren.

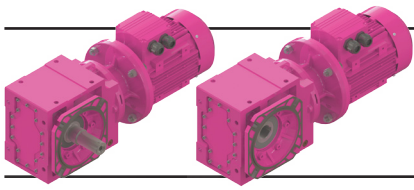

Ölçü Sayfaları

Dimension Pages

Abmessungsseiten

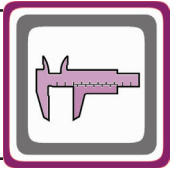

-Mil ucu çekirme deliği DIN 332 sayfa 2 / Tapped center hole to DIN 332, sheet 2 / Zentrierung mit Gewinde DIN 332, Blatt 2

KV675.02
KV676.02

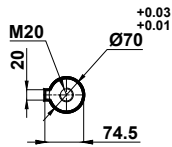
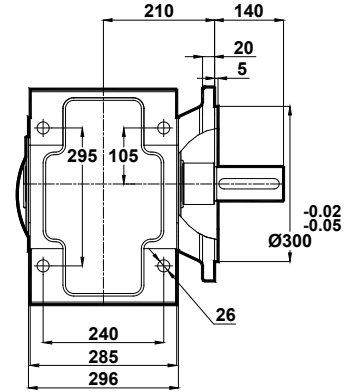
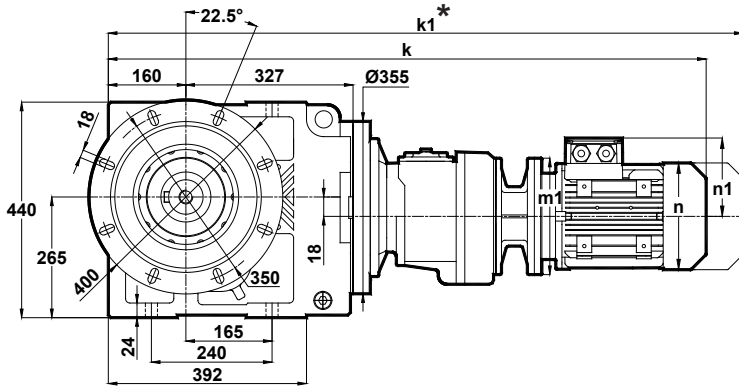

Klemens Pozisyonları
Terminal Box Positions
Klemmenkasten Positionen

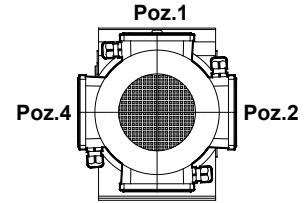

Poz.1

71-80-90

Tip / Type / Typ

Opsiyonel flanş ölçüleri için sayfa 587'ye bakınız.
Please see on page 587 for optional flange dimensions
Siehe Seite 587 für auswählbare Flanschabmessungen

	71/B5	80/B5 80/B14	90S/B5 90S/B14	90L/B5 90L/B14
k	1007.5	1030.5	1071.5	1071.5
k1	1098.5	1123.5	1175	1175
n / n1	137 / 112	155 / 123	176 / 132	176 / 132
m1 (B5)	160	200	200	200
m1 (B14)	-	120	140	140

KV675.03
KV676.03

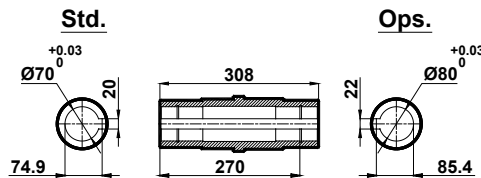
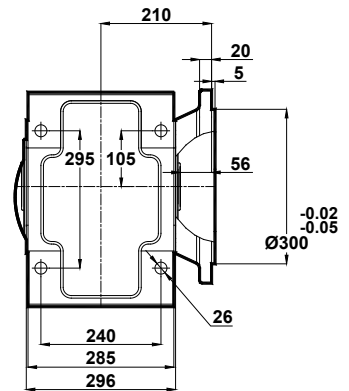
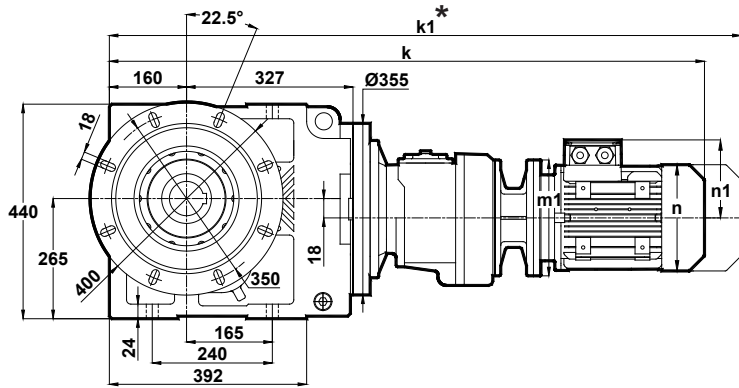

	71/B5	80/B5 80/B14	90S/B5 90S/B14	90L/B5 90L/B14
k	1007.5	1030.5	1071.5	1071.5
k1	1098.5	1123.5	1175	1175
n / n1	137 / 112	155 / 123	176 / 132	176 / 132
m1 (B5)	160	200	200	200
m1 (B14)	-	120	140	140

Opsiyonel flanş ölçüleri için sayfa 587'ye bakınız.
Please see on page 587 for optional flange dimensions
Siehe Seite 587 für auswählbare Flanschabmessungen

* " k1 " Ölçüsü frenli redüktörlere aittir.
Dimension " k1 " is for motors with brake.
Maße " k1 " ist für Bremsenmotoren.

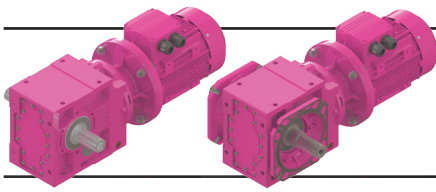

Ölçü Sayfaları

Dimension Pages

Abmessungsseiten

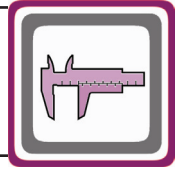

-Mil ucu çektirme deliği DIN 332 sayfa 2 / Tapped center hole to DIN 332, sheet 2 / Zentrierung mit Gewinde DIN 332, Blatt 2

KV675.04
KV676.04

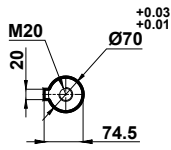
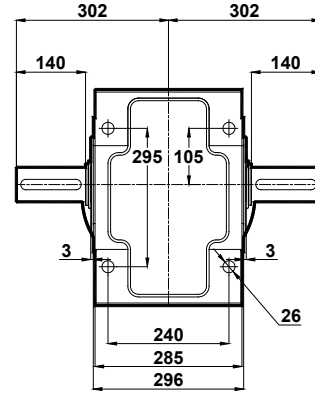
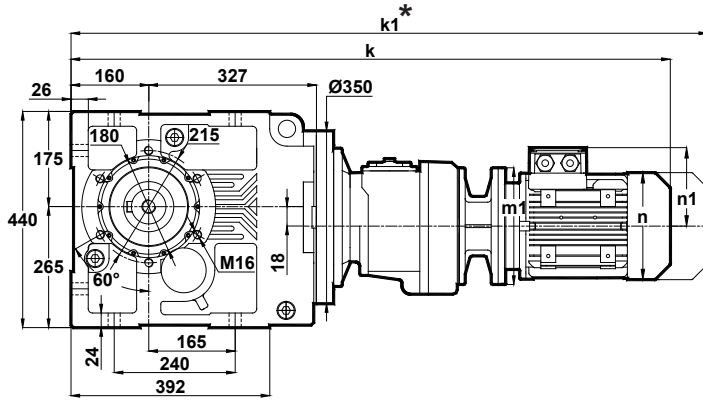

	71/B5	80/B5 80/B14	90S/B5 90S/B14	90L/B5 90L/B14
k	1007.5	1030.5	1071.5	1071.5
k1	1098.5	1123.5	1175	1175
n / n1	137 / 112	155 / 123	176 / 132	176 / 132
m1 (B5)	160	200	200	200
m1 (B14)	-	120	140	140

Klemens Pozisyonları
Terminal Box Positions
Klemmenkasten Positionen

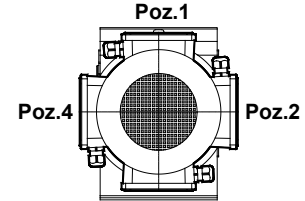

Poz.1
Poz.2
Poz.3
71-80-90
Tip / Type / Typ

KV675.05
KV676.05

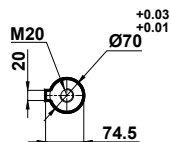
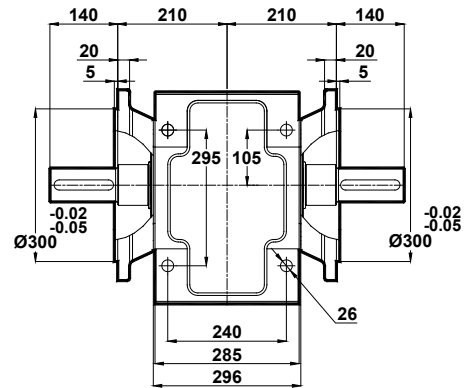
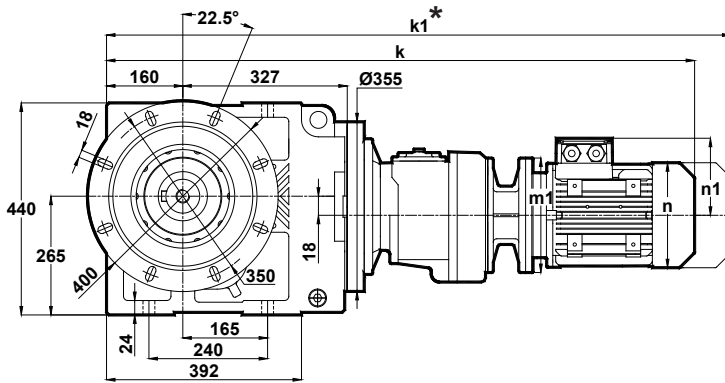

	71/B5	80/B5 80/B14	90S/B5 90S/B14	90L/B5 90L/B14
k	1007.5	1030.5	1071.5	1071.5
k1	1098.5	1123.5	1175	1175
n / n1	137 / 112	155 / 123	176 / 132	176 / 132
m1 (B5)	160	200	200	200
m1 (B14)	-	120	140	140

Opsiyonel flanş ölçüleri için sayfa 587'ye bakınız.
Please see on page 587 for optional flange dimensions
Siehe Seite 587 für auswählbare Flanschabmessungen

* " k1 " Ölçüsü frenli redüktörlere aittir.
Dimension " k1 " is for motors with brake.
Maße " k1 " ist für Bremsenmotoren.

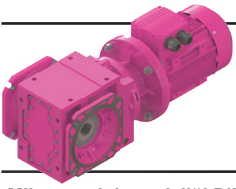

Ölçü Sayfaları Dimension Pages Abmessungenseiten

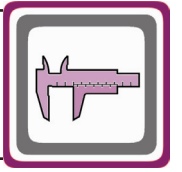

-Mil ucu çektirme deliği DIN 332 sayfa 2 / Tapped center hole to DIN 332, sheet 2 / Zentrierung mit Gewinde DIN 332, Blatt 2

KV675.08
KV676.08

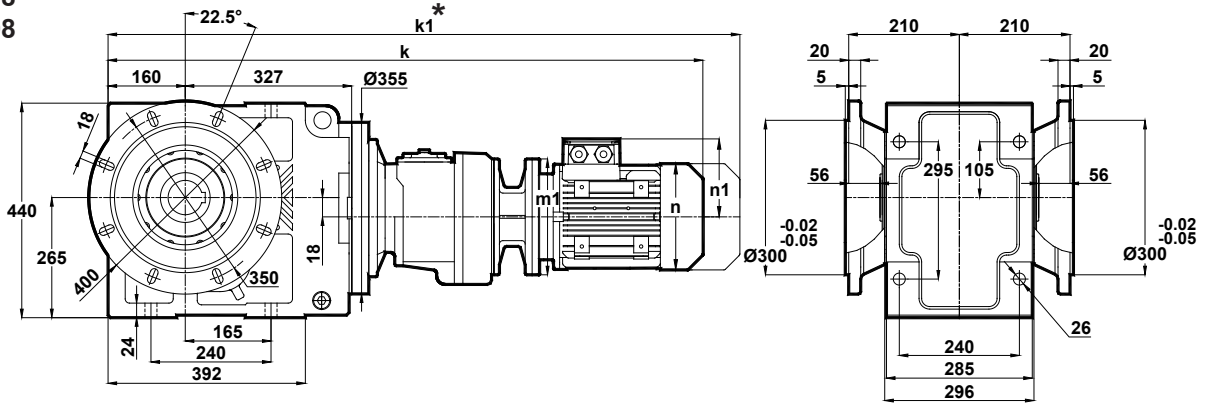

Std.

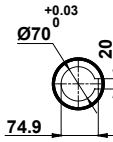

Ops.

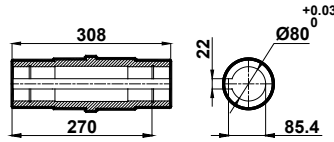

	71/B5	80/B5 80/B14	90S/B5 90S/B14	90L/B5 90L/B14
k	1007.5	1030.5	1071.5	1071.5
k1	1098.5	1123.5	1175	1175
n / n1	137 / 112	155 / 123	176 / 132	176 / 132
m1 (B5)	160	200	200	200
m1 (B14)	-	120	140	140

Klemens Pozisyonları
Terminal Box Positions
Klemmenkasten Positionen

Poz.1

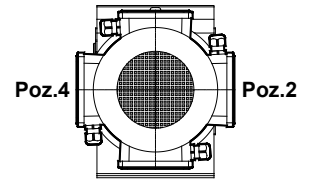

Poz.3

71-80-90
Tip / Type / Typ

Opsiyonel flanş ölçüleri için sayfa 587'ye bakınız.
Please see on page 587 for optional flange dimensions
Siehe Seite 587 für auswählbare Flanschabmessungen

* "k1" Ölçüsü frenli redüktörlere aittir.
Dimension "k1" is for motors with brake.
Maße "k1" ist für Bremsenmotoren.

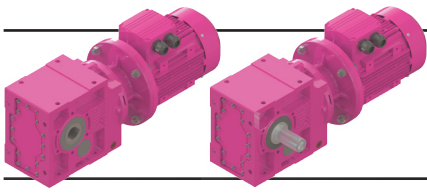

Ölçü Sayfaları

Dimension Pages

Abmessungsseiten

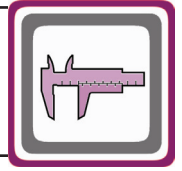

-Mil ucu çektirme deliği DIN 332 sayfa 2 / Tapped center hole to DIN 332, sheet 2 / Zentrierung mit Gewinde DIN 332, Blatt 2

KV773.00

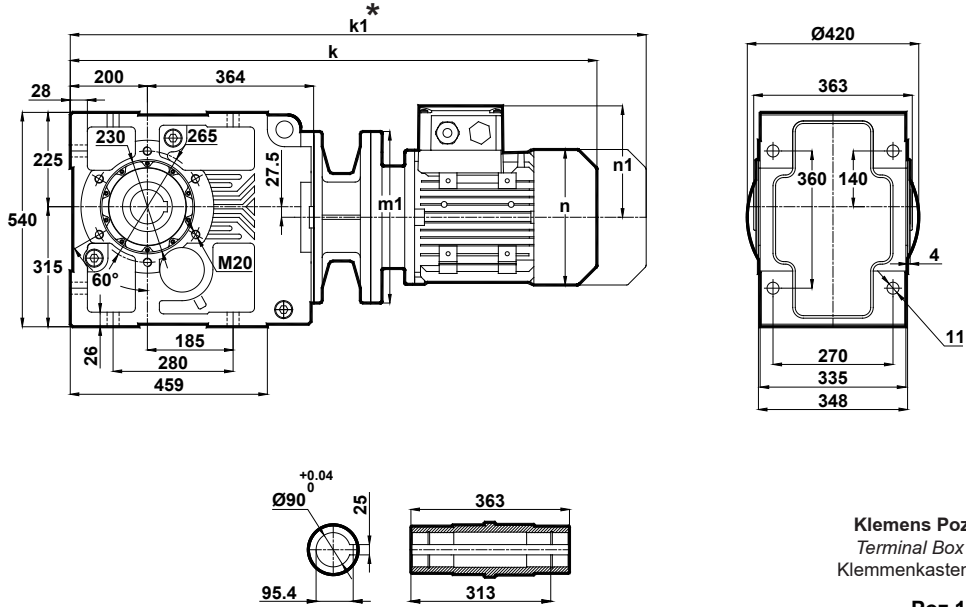

Klemens Pozisyonları
Terminal Box Positions
Klemmenkasten Positionen

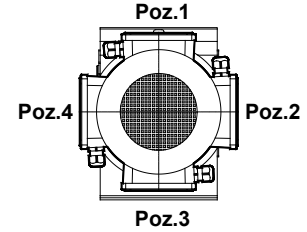

132-160-180-200-225-250
Tip / Type / Typ

	132S/B5	132M/B5	160M/B5	160L/B5	180M/B5	180L/B5	200L/B5	225S/B5	225M/B5	250M/B5
k	1062.5	1062.5	1212	1212	1300	1300	1376	1447	1472	1548
k1	1192.5	1192.5	1360	1360	1458.5	1458.5	1562.5	1612	1637	1718.5
n / n1	257 / 181	257 / 181	316 / 224	316 / 224	348 / 250	348 / 250	396 / 287	438 / 316	438 / 316	481 / 335
m1 (B5)	300	300	350	350	350	350	400	450	450	550
m1 (B14)	-	-	-	-	-	-	-	-	-	-

KV773.01

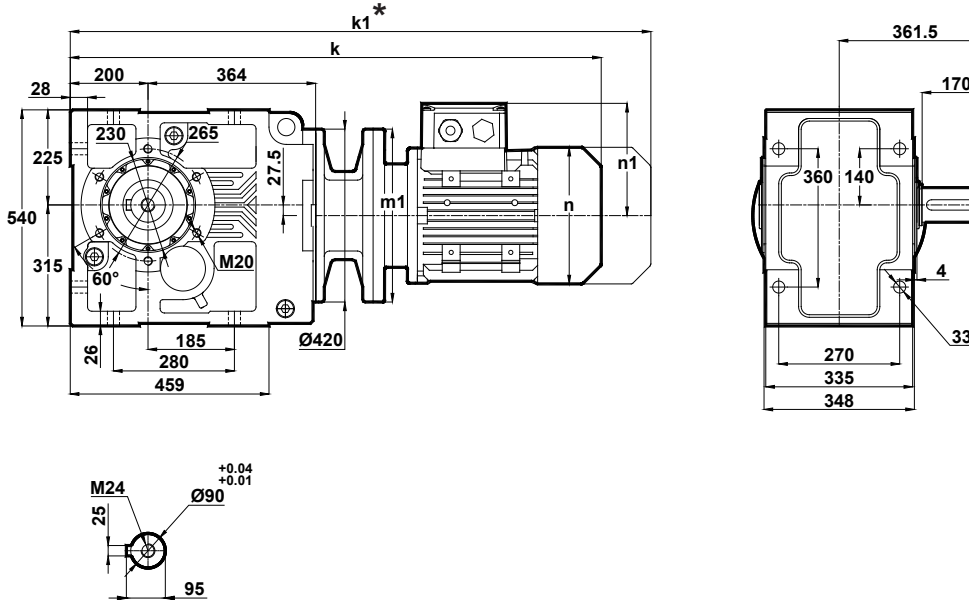

	132S/B5	132M/B5	160M/B5	160L/B5	180M/B5	180L/B5	200L/B5	225S/B5	225M/B5	250M/B5
k	1062.5	1062.5	1212	1212	1300	1300	1376	1447	1472	1548
k1	1192.5	1192.5	1360	1360	1458.5	1458.5	1562.5	1612	1637	1718.5
n / n1	257 / 181	257 / 181	316 / 224	316 / 224	348 / 250	348 / 250	396 / 287	438 / 316	438 / 316	481 / 335
m1 (B5)	300	300	350	350	350	350	400	450	450	550
m1 (B14)	-	-	-	-	-	-	-	-	-	-

* " k1 " Ölçüsü frenli redüktörlere aittir.
Dimension " k1 " is for motors with brake.
Maße " k1 " ist für Bremsenmotoren.

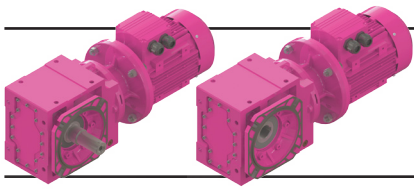

Ölçü Sayfaları Dimension Pages Abmessungsseiten



-Mil ucu çektirme deliği DIN 332 sayfa 2 / Tapped center hole to DIN 332, sheet 2 / Zentrierung mit Gewinde DIN 332, Blatt 2

KV773.02

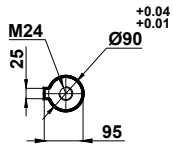
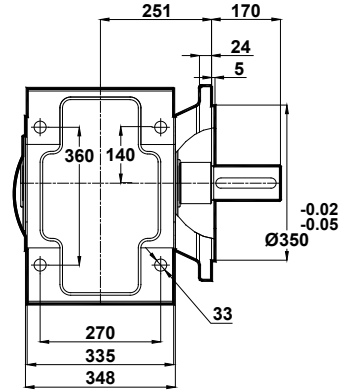
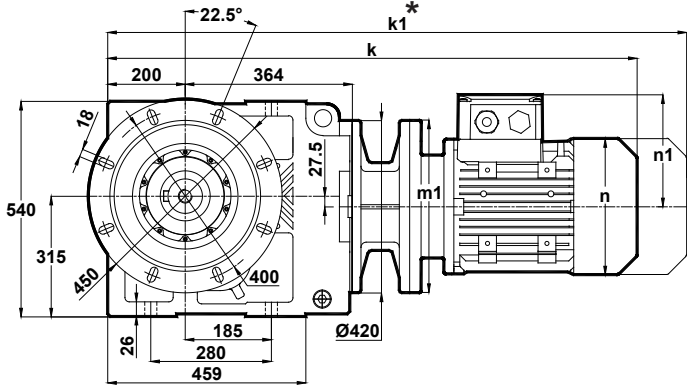

Klemens Pozisyonları
Terminal Box Positions
Klemmenkasten Positionen

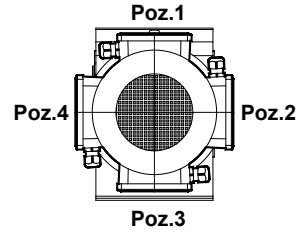

132-160-180-200-225-250
Tip / Type / Typ

	132S/B5	132M/B5	160M/B5	160L/B5	180M/B5	180L/B5	200L/B5	225S/B5	225M/B5	250M/B5
k	1062.5	1062.5	1212	1212	1300	1300	1376	1447	1472	1548
k1	1192.5	1192.5	1360	1360	1458.5	1458.5	1562.5	1612	1637	1718.5
n / n1	257 / 181	257 / 181	316 / 224	316 / 224	348 / 250	348 / 250	396 / 287	438 / 316	438 / 316	481 / 335
m1 (B5)	300	300	350	350	350	350	400	450	450	550
m1 (B14)	-	-	-	-	-	-	-	-	-	-

Opsiyonel flanş ölçüleri için sayfa 587'ye bakınız.
Please see on page 587 for optional flange dimensions
Siehe Seite 587 für auswählbare Flanschabmessungen

KV773.03

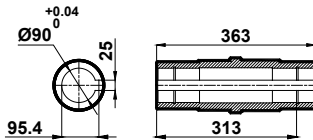
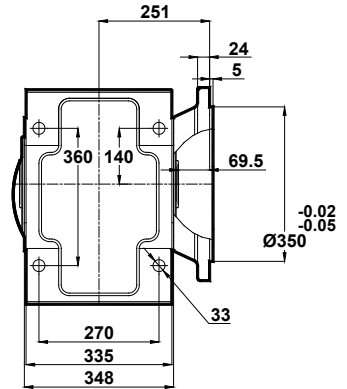
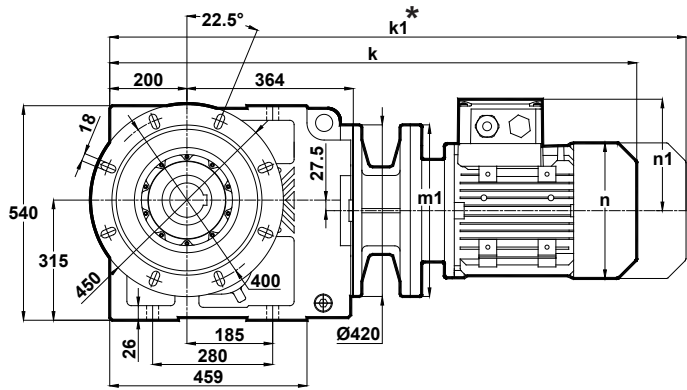

Opsiyonel flanş ölçüleri için sayfa 587'ye bakınız.
Please see on page 587 for optional flange dimensions
Siehe Seite 587 für auswählbare Flanschabmessungen

	132S/B5	132M/B5	160M/B5	160L/B5	180M/B5	180L/B5	200L/B5	225S/B5	225M/B5	250M/B5
k	1062.5	1062.5	1212	1212	1300	1300	1376	1447	1472	1548
k1	1192.5	1192.5	1360	1360	1458.5	1458.5	1562.5	1612	1637	1718.5
n / n1	257 / 181	257 / 181	316 / 224	316 / 224	348 / 250	348 / 250	396 / 287	438 / 316	438 / 316	481 / 335
m1 (B5)	300	300	350	350	350	350	400	450	450	550
m1 (B14)	-	-	-	-	-	-	-	-	-	-

* " k1 " Ölçüsü frenli redüktörlere aittir.
Dimension " k1 " is for motors with brake.
Maße " k1 " ist für Bremsenmotoren.

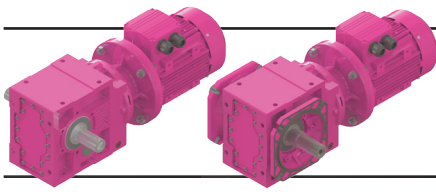

Ölçü Sayfaları

Dimension Pages

Abmessungsseiten

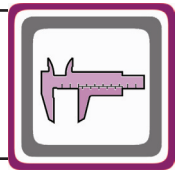

-Mil ucu çektirme deliği DIN 332 sayfa 2 / Tapped center hole to DIN 332, sheet 2 / Zentrierung mit Gewinde DIN 332, Blatt 2

KV773.04

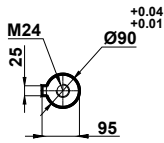
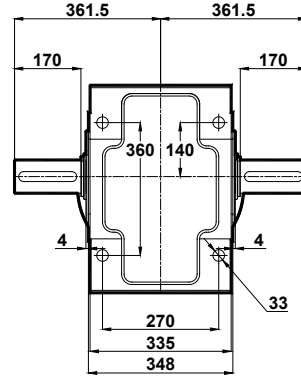
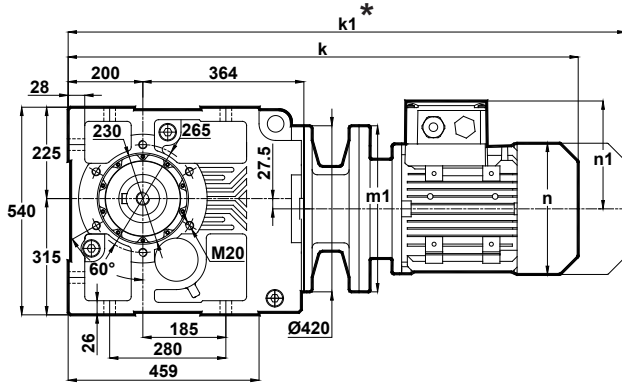

Klemens Pozisyonları
Terminal Box Positions
Klemmenkasten Positionen

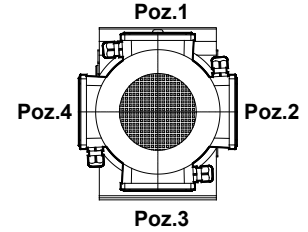

132-160-180-200-225-250
Tip / Type / Typ

	132S/B5	132M/B5	160M/B5	160L/B5	180M/B5	180L/B5	200L/B5	225S/B5	225M/B5	250M/B5
k	1062.5	1062.5	1212	1212	1300	1300	1376	1447	1472	1548
k1	1192.5	1192.5	1360	1360	1458.5	1458.5	1562.5	1612	1637	1718.5
n / n1	257 / 181	257 / 181	316 / 224	316 / 224	348 / 250	348 / 250	396 / 287	438 / 316	438 / 316	481 / 335
m1 (B5)	300	300	350	350	350	350	400	450	450	550
m1 (B14)	-	-	-	-	-	-	-	-	-	-

KV773.05

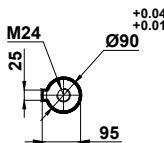
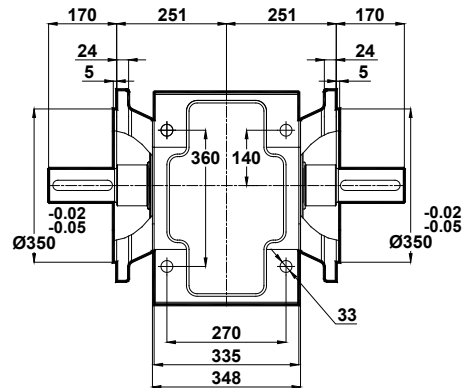
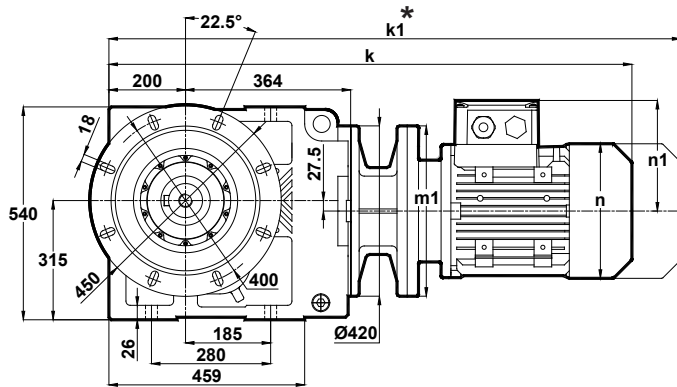

Opsiyonel flanş ölçüleri için sayfa 587'ye bakınız.
Please see on page 587 for optional flange dimensions
Siehe Seite 587 für auswählbare Flanschabmessungen

	132S/B5	132M/B5	160M/B5	160L/B5	180M/B5	180L/B5	200L/B5	225S/B5	225M/B5	250M/B5
k	1062.5	1062.5	1212	1212	1300	1300	1376	1447	1472	1548
k1	1192.5	1192.5	1360	1360	1458.5	1458.5	1562.5	1612	1637	1718.5
n / n1	257 / 181	257 / 181	316 / 224	316 / 224	348 / 250	348 / 250	396 / 287	438 / 316	438 / 316	481 / 335
m1 (B5)	300	300	350	350	350	350	400	450	450	550
m1 (B14)	-	-	-	-	-	-	-	-	-	-

* " k1 " Ölçüsü frenli redüktörlere aittir.
Dimension " k1 " is for motors with brake.
Maße " k1 " ist für Bremsenmotoren.

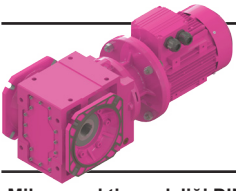

Ölçü Sayfaları Dimension Pages Abmessungsseiten



-Mil ucu çektirme deliği DIN 332 sayfa 2 / Tapped center hole to DIN 332, sheet 2 / Zentrierung mit Gewinde DIN 332, Blatt 2

KV773.08

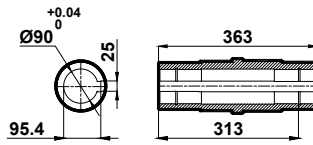
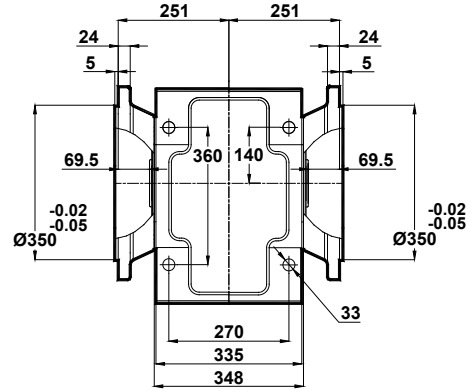
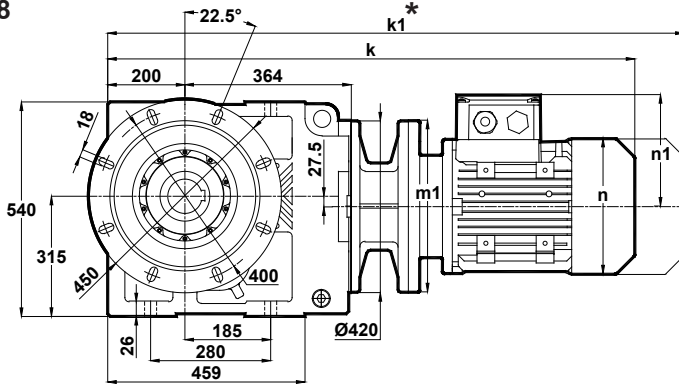

Klemens Pozisyonları
Terminal Box Positions
Klemmenkasten Positionen

Poz.1

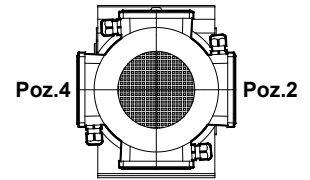

Poz.3

132-160-180-200-225-250
Tip / Type / Typ

	132S/B5	132M/B5	160M/B5	160L/B5	180M/B5	180L/B5	200L/B5	225S/B5	225M/B5	250M/B5
k	1062.5	1062.5	1212	1212	1300	1300	1376	1447	1472	1548
k1	1192.5	1192.5	1360	1360	1458.5	1458.5	1562.5	1612	1637	1718.5
n / n1	257 / 181	257 / 181	316 / 224	316 / 224	348 / 250	348 / 250	396 / 287	438 / 316	438 / 316	481 / 335
m1 (B5)	300	300	350	350	350	350	400	450	450	550
m1 (B14)	-	-	-	-	-	-	-	-	-	-

Opsiyonel flanş ölçüleri için sayfa 587'ye bakınız.
Please see on page 587 for optional flange dimensions
Siehe Seite 587 für auswählbare Flanschabmessungen

* " k1 " Ölçüsü frenli redüktörlere aittir.
Dimension " k1 " is for motors with brake.
Maße " k1 " ist für Bremsenmotoren.

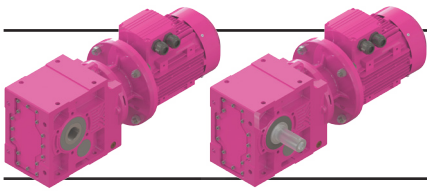

Ölçü Sayfaları

Dimension Pages

Abmessungsseiten

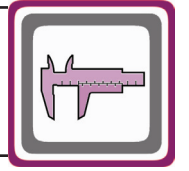

-Mil ucu çektirme deliği DIN 332 sayfa 2 / Tapped center hole to DIN 332, sheet 2 / Zentrierung mit Gewinde DIN 332, Blatt 2

KV774.00

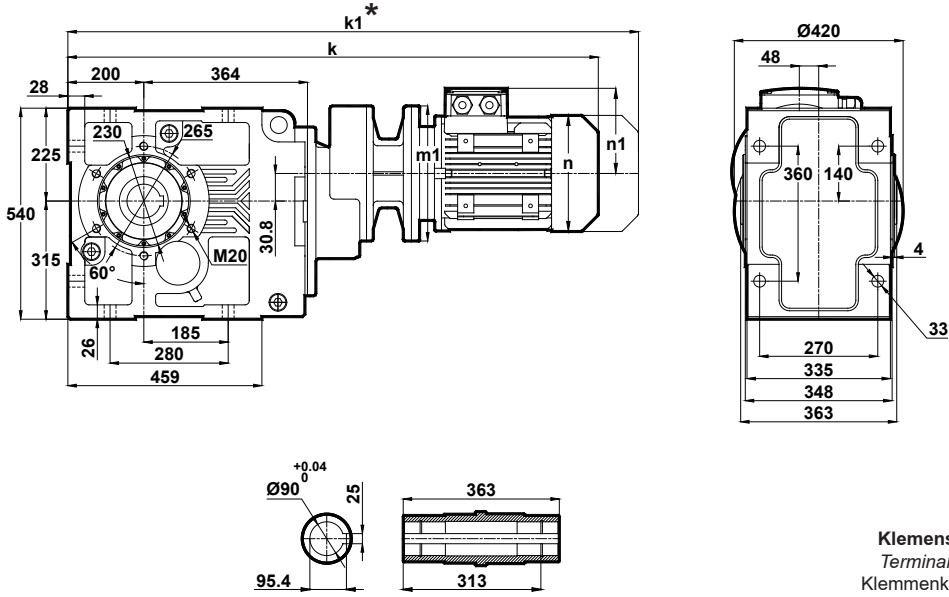

	90S/B5 90S/B14	90L/B5 90L/B14	100L/B5 100L/B14	112M/B5 112M/B14	132S/B5 132S/B14	132M/B5 132M/B14
k	997.5	997.5	1051.5	1072	1174.5	1174.5
k1	1101	1101	1160	1176.5	1304.5	1304.5
n / n1	176 / 132	176 / 132	193 / 149	215 / 161	257 / 181	257 / 181
m1 (B5)	200	200	250	250	300	300
m1 (B14)	140	140	160	160	200	200

Klemens Pozisyonları
Terminal Box Positions
Klemmenkasten Positionen

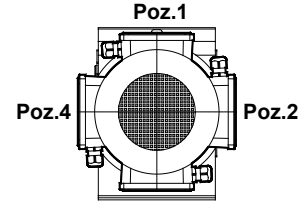

Poz.3

90-100-112-132
Tip / Type / Typ

KV774.01

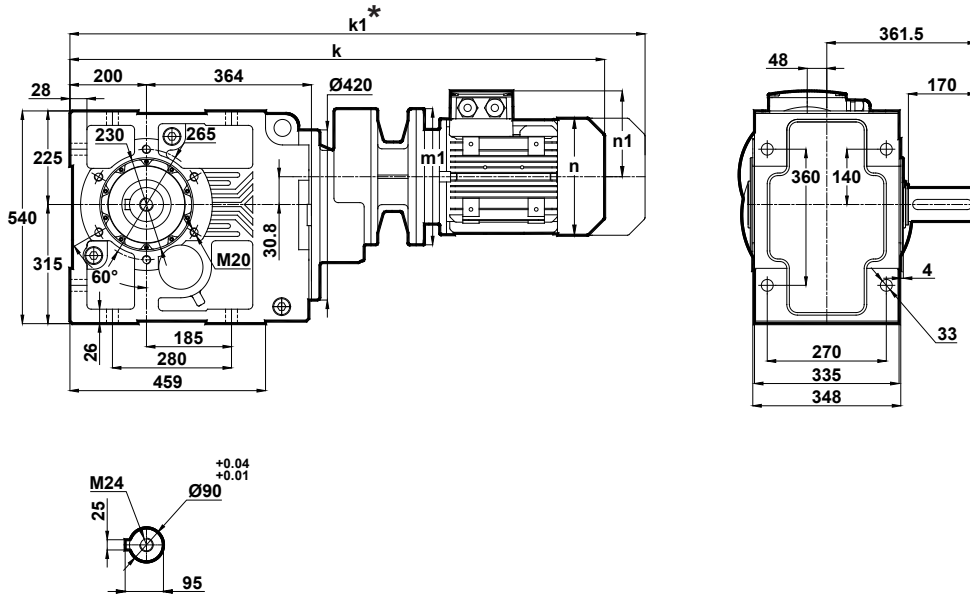

	90S/B5 90S/B14	90L/B5 90L/B14	100L/B5 100L/B14	112M/B5 112M/B14	132S/B5 132S/B14	132M/B5 132M/B14
k	997.5	997.5	1051.5	1072	1174.5	1174.5
k1	1101	1101	1160	1176.5	1304.5	1304.5
n / n1	176 / 132	176 / 132	193 / 149	215 / 161	257 / 181	257 / 181
m1 (B5)	200	200	250	250	300	300
m1 (B14)	140	140	160	160	200	200

* " k1 " Ölçüsü frenli redüktörlere aittir.
Dimension " k1 " is for motors with brake.
Maße " k1 " ist für Bremsenmotoren.

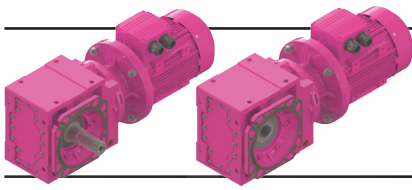

Ölçü Sayfaları Dimension Pages Abmessungsseiten

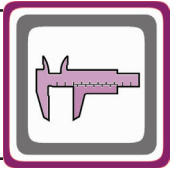

-Mil ucu çekirme deliği DIN 332 sayfa 2 / Tapped center hole to DIN 332, sheet 2 / Zentrierung mit Gewinde DIN 332, Blatt 2

KV774.02

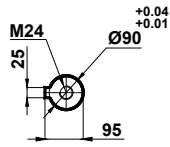
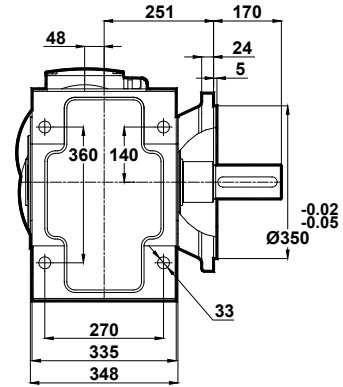
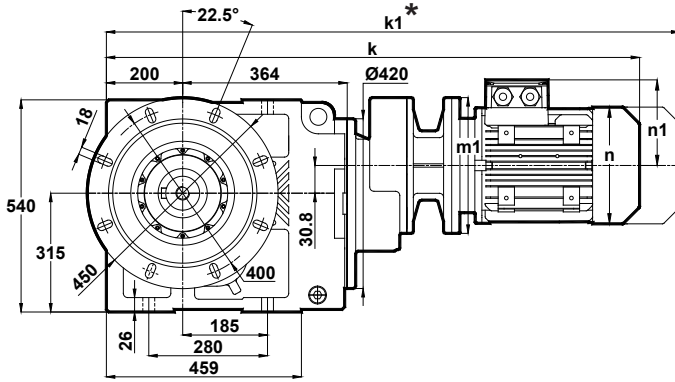

Klemens Pozisyonları
Terminal Box Positions
Klemmenkasten Positionen

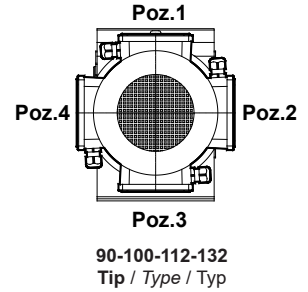

	90S/B5 90S/B14	90L/B5 90L/B14	100L/B5 100L/B14	112M/B5 112M/B14	132S/B5 132S/B14	132M/B5 132M/B14
k	997.5	997.5	1051.5	1072	1174.5	1174.5
k1	1101	1101	1160	1176.5	1304.5	1304.5
n / n1	176 / 132	176 / 132	193 / 149	215 / 161	257 / 181	257 / 181
m1 (B5)	200	200	250	250	300	300
m1 (B14)	140	140	160	160	200	200

Opsiyonel flanş ölçüleri için sayfa 587'ye bakınız.
Please see on page 587 for optional flange dimensions
Siehe Seite 587 für auswählbare Flanschabmessungen

KV774.03

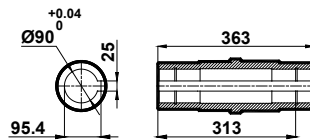
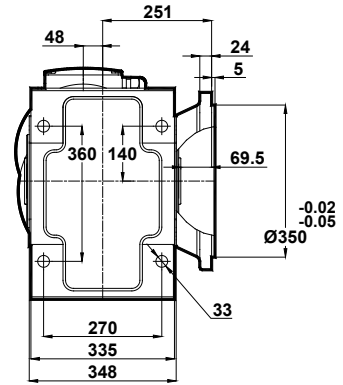
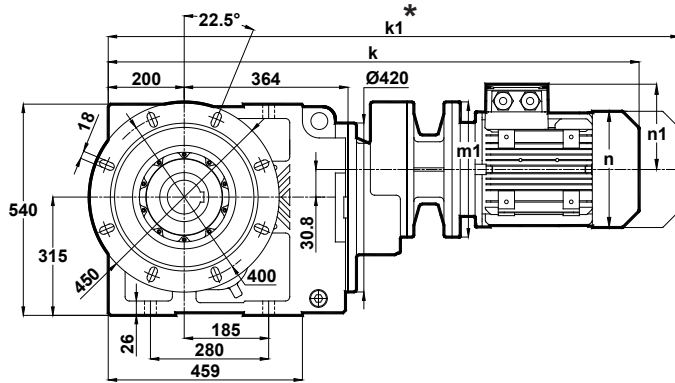

	90S/B5 90S/B14	90L/B5 90L/B14	100L/B5 100L/B14	112M/B5 112M/B14	132S/B5 132S/B14	132M/B5 132M/B14
k	997.5	997.5	1051.5	1072	1174.5	1174.5
k1	1101	1101	1160	1176.5	1304.5	1304.5
n / n1	176 / 132	176 / 132	193 / 149	215 / 161	257 / 181	257 / 181
m1 (B5)	200	200	250	250	300	300
m1 (B14)	140	140	160	160	200	200

Opsiyonel flanş ölçüleri için sayfa 587'ye bakınız.
Please see on page 587 for optional flange dimensions
Siehe Seite 587 für auswählbare Flanschabmessungen

* "k1" Ölçüsü frenli redüktörlere aittir.
Dimension "k1" is for motors with brake.
Maße "k1" ist für Bremsenmotoren.

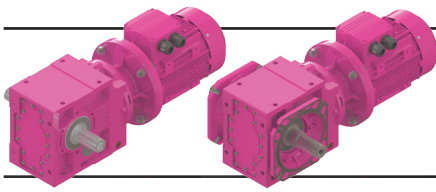

Ölçü Sayfaları Dimension Pages Abmessungsseiten

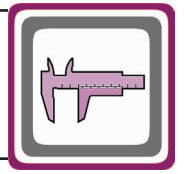

-Mil ucu çektirme deliği DIN 332 sayfa 2 / Tapped center hole to DIN 332, sheet 2 / Zentrierung mit Gewinde DIN 332, Blatt 2

KV774.04

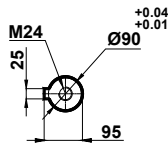
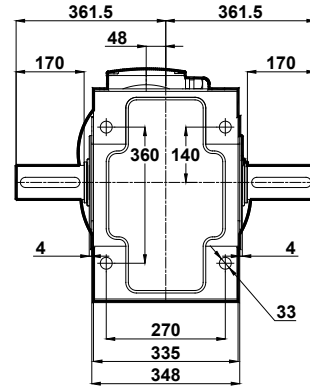
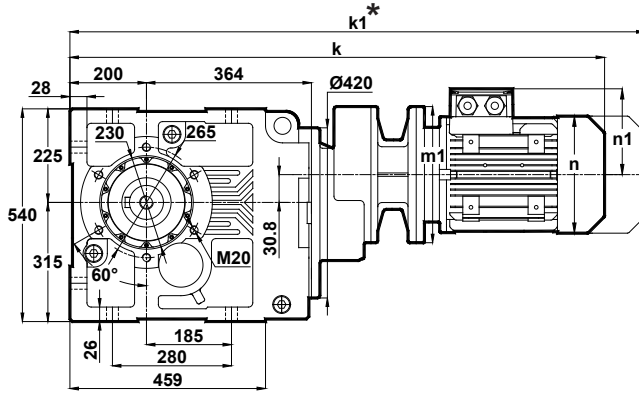

	90S/B5 90S/B14	90L/B5 90L/B14	100L/B5 100L/B14	112M/B5 112M/B14	132S/B5 132S/B14	132M/B5 132M/B14
k	997.5	997.5	1051.5	1072	1174.5	1174.5
k1	1101	1101	1160	1176.5	1304.5	1304.5
n / n1	176 / 132	176 / 132	193 / 149	215 / 161	257 / 181	257 / 181
m1 (B5)	200	200	250	250	300	300
m1 (B14)	140	140	160	160	200	200

Klemens Pozisyonları
Terminal Box Positions
Klemmenkasten Positionen

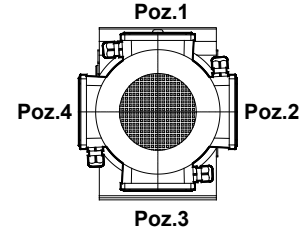

Poz.3

90-100-112-132
Tip / Type / Typ

KV774.05

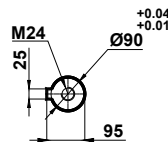
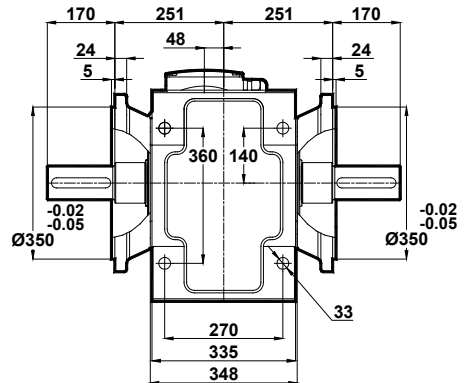
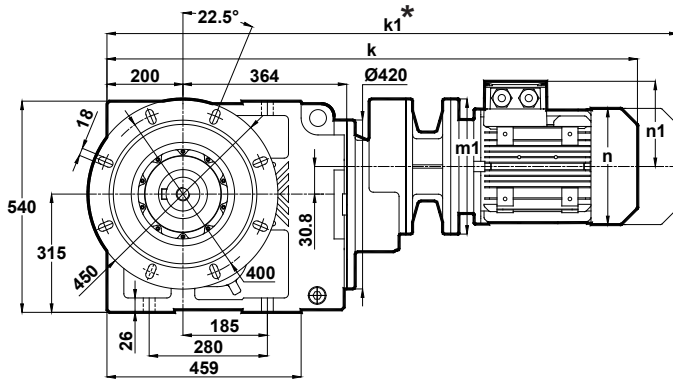

	90S/B5 90S/B14	90L/B5 90L/B14	100L/B5 100L/B14	112M/B5 112M/B14	132S/B5 132S/B14	132M/B5 132M/B14
k	997.5	997.5	1051.5	1072	1174.5	1174.5
k1	1101	1101	1160	1176.5	1304.5	1304.5
n / n1	176 / 132	176 / 132	193 / 149	215 / 161	257 / 181	257 / 181
m1 (B5)	200	200	250	250	300	300
m1 (B14)	140	140	160	160	200	200

Opsiyonel flanş ölçüleri için sayfa 587'ye bakınız.
Please see on page 587 for optional flange dimensions
Siehe Seite 587 für auswählbare Flanschabmessungen

* " k1 " Ölçüsü frenli redüktörlere aittir.
Dimension " k1 " is for motors with brake.
Maße " k1 " ist für Bremsenmotoren.

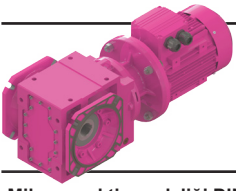

Ölçü Sayfaları Dimension Pages Abmessungsseiten

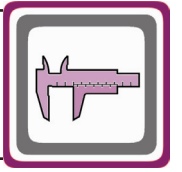

-Mil ucu çektirme deliği DIN 332 sayfa 2 / Tapped center hole to DIN 332, sheet 2 / Zentrierung mit Gewinde DIN 332, Blatt 2

KV774.08

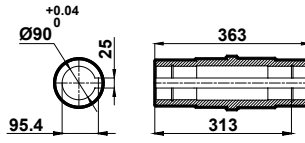
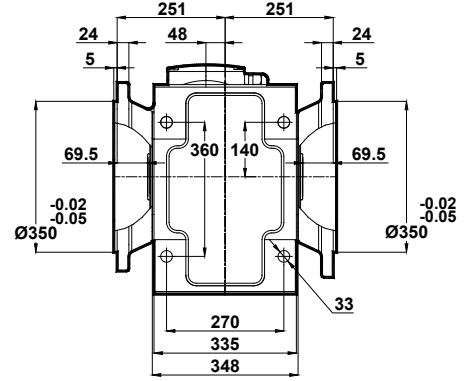
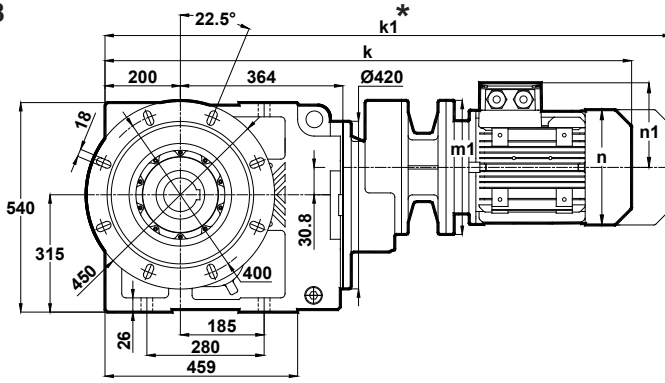

	90S/B5 90S/B14	90L/B5 90L/B14	100L/B5 100L/B14	112M/B5 112M/B14	132S/B5 132S/B14	132M/B5 132M/B14
k	997.5	997.5	1051.5	1072	1174.5	1174.5
k1	1101	1101	1160	1176.5	1304.5	1304.5
n / n1	176 / 132	176 / 132	193 / 149	215 / 161	257 / 181	257 / 181
m1 (B5)	200	200	250	250	300	300
m1 (B14)	140	140	160	160	200	200

Klemens Pozisyonları
Terminal Box Positions
Klemmenkasten Positionen

Poz.1

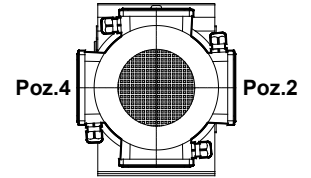

Poz.3

90-100-112-132
Tip / Type / Typ

Opsiyonel flanş ölçüleri için sayfa 587'ye bakınız.
Please see on page 587 for optional flange dimensions
Siehe Seite 587 für auswählbare Flanschabmessungen

* " k1 " Ölçüsü frenli redüktörlere aittir.
Dimension " k1 " is for motors with brake.
Maße " k1 " ist für Bremsenmotoren.

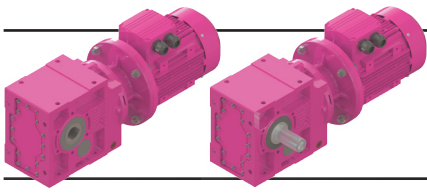

Ölçü Sayfaları

Dimension Pages

Abmessungsseiten

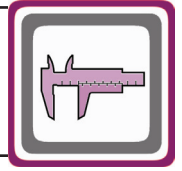

-Mil ucu çektirme deliği DIN 332 sayfa 2 / Tapped center hole to DIN 332, sheet 2 / Zentrierung mit Gewinde DIN 332, Blatt 2

KV775.00
KV776.00

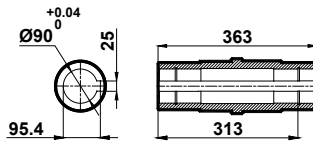
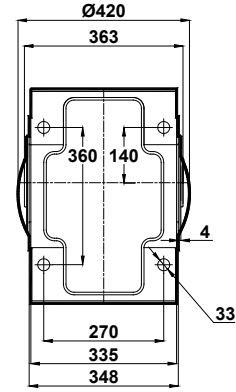
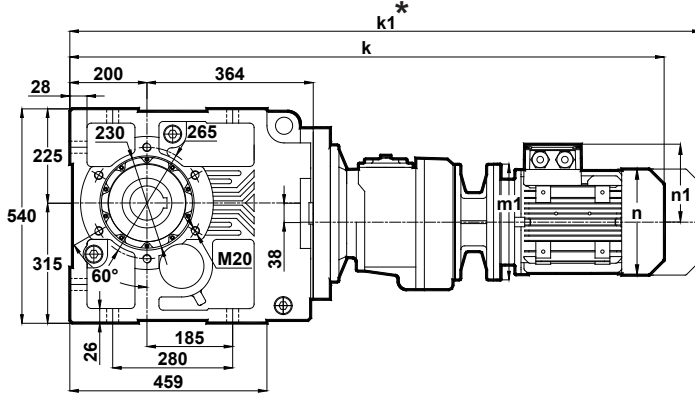

Klemens Pozisyonları
Terminal Box Positions
Klemmenkasten Positionen

	71/B5	80/B5 80/B14	90S/B5 90S/B14	90L/B5 90L/B14	100L/B5 100L/B14
k	1084.5	1107.5	1148.5	1148.5	1201
k1	1175.5	1200.5	1252	1252	1309.5
n / n1	137 / 112	155 / 123	176 / 132	176 / 132	193 / 149
m1 (B5)	160	200	200	200	250
m1 (B14)	-	120	140	140	160

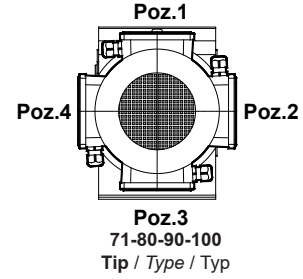

KV775.01
KV776.01

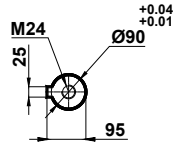
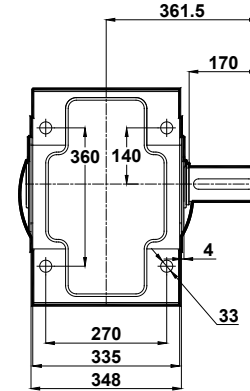
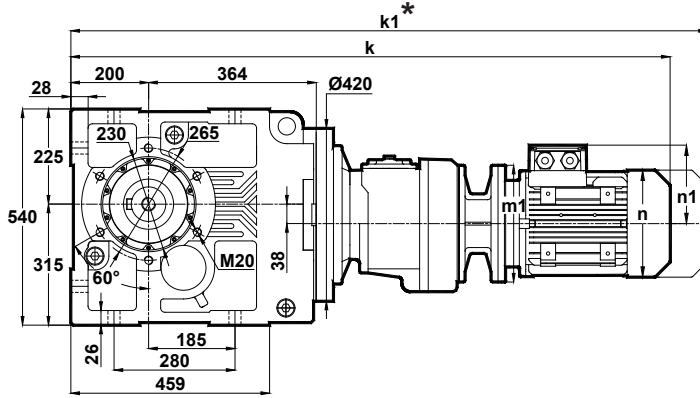

	71/B5	80/B5 80/B14	90S/B5 90S/B14	90L/B5 90L/B14	100L/B5 100L/B14
k	1084.5	1107.5	1148.5	1148.5	1201
k1	1175.5	1200.5	1252	1252	1309.5
n / n1	137 / 112	155 / 123	176 / 132	176 / 132	193 / 149
m1 (B5)	160	200	200	200	250
m1 (B14)	-	120	140	140	160

* " k1 " Ölçüsü frenli redüktörlere aittir.
Dimension " k1 " is for motors with brake.
Maße " k1 " ist für Bremsenmotoren.

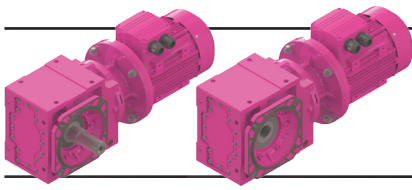

Ölçü Sayfaları

Dimension Pages

Abmessungsseiten

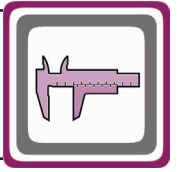

-Mil ucu çektirme deliği DIN 332 sayfa 2 / Tapped center hole to DIN 332, sheet 2 / Zentrierung mit Gewinde DIN 332, Blatt 2

KV775.02
KV776.02

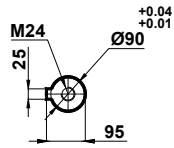
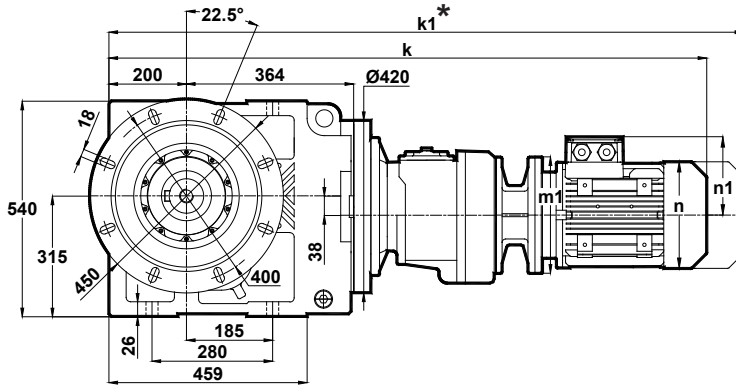

	71/B5	80/B5 80/B14	90S/B5 90S/B14	90L/B5 90L/B14	100L/B5 100L/B14
k	1084.5	1107.5	1148.5	1148.5	1201
k1	1175.5	1200.5	1252	1252	1309.5
n / n1	137 / 112	155 / 123	176 / 132	176 / 132	193 / 149
m1 (B5)	160	200	200	200	250
m1 (B14)	-	120	140	140	160

Klemens Pozisyonları
Terminal Box Positions
Klemmenkasten Positionen

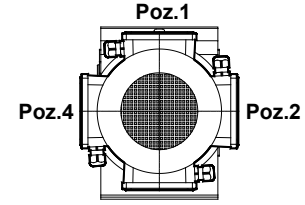

Poz.3
71-80-90-100
Tip / Type / Typ

Opsiyonel flanş ölçüleri için sayfa 587'ye bakınız.
Please see on page 587 for optional flange dimensions
Siehe Seite 587 für auswählbare Flanschabmessungen

KV775.03
KV776.03

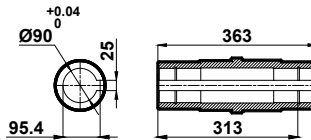
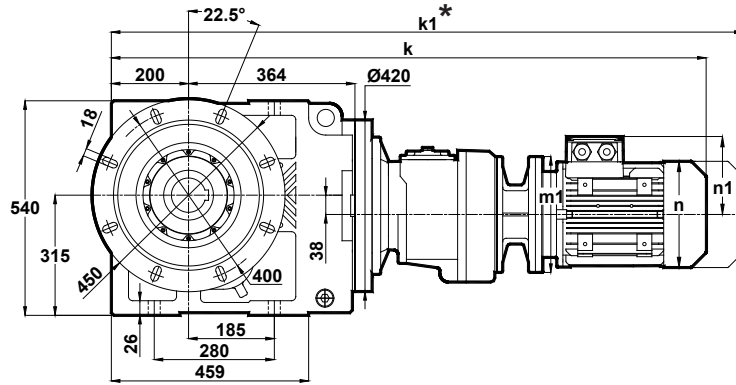

	71/B5	80/B5 80/B14	90S/B5 90S/B14	90L/B5 90L/B14	100L/B5 100L/B14
k	1084.5	1107.5	1148.5	1148.5	1201
k1	1175.5	1200.5	1252	1252	1309.5
n / n1	137 / 112	155 / 123	176 / 132	176 / 132	193 / 149
m1 (B5)	160	200	200	200	250
m1 (B14)	-	120	140	140	160

Opsiyonel flanş ölçüleri için sayfa 587'ye bakınız.
Please see on page 587 for optional flange dimensions
Siehe Seite 587 für auswählbare Flanschabmessungen

* " k1 " Ölçüsü frenli redüktörlere aittir.
Dimension " k1 " is for motors with brake.
Maße " k1 " ist für Bremsenmotoren.

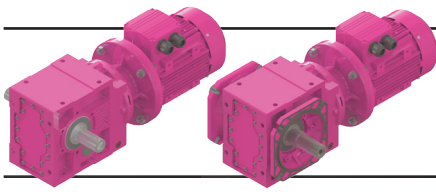

Ölçü Sayfaları

Dimension Pages

Abmessungsseiten

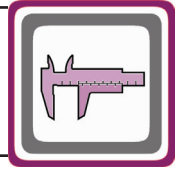

-Mil ucu çektirme deliği DIN 332 sayfa 2 / Tapped center hole to DIN 332, sheet 2 / Zentrierung mit Gewinde DIN 332, Blatt 2

KV775.04
KV776.04

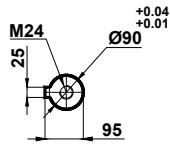
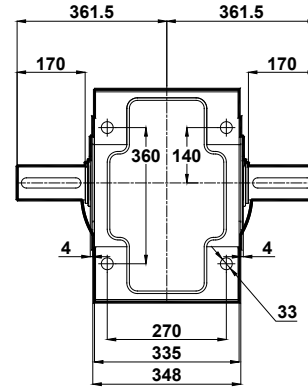
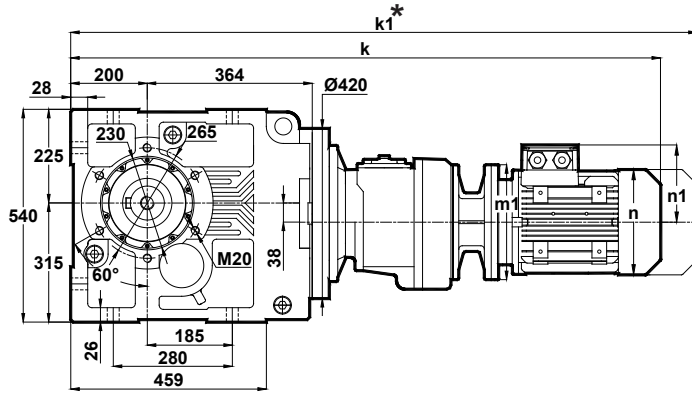

Klemens Pozisyonları
Terminal Box Positions
Klemmenkasten Positionen

	71/B5	80/B5 80/B14	90S/B5 90S/B14	90L/B5 90L/B14	100L/B5 100L/B14
k	1084.5	1107.5	1148.5	1148.5	1201
k1	1175.5	1200.5	1252	1252	1309.5
n / n1	137 / 112	155 / 123	176 / 132	176 / 132	193 / 149
m1 (B5)	160	200	200	200	250
m1 (B14)	-	120	140	140	160

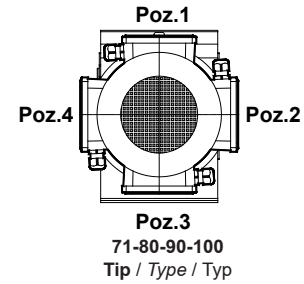

KV775.05
KV776.05

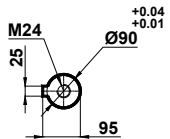
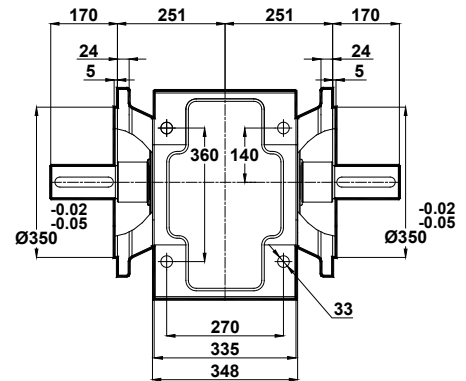
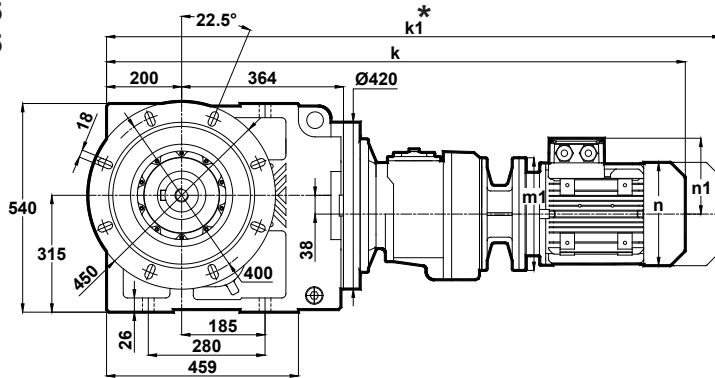

Opsiyonel flanş ölçüleri için sayfa 587'ye bakınız.
Please see on page 587 for optional flange dimensions
Siehe Seite 587 für auswählbare Flanschabmessungen

	71/B5	80/B5 80/B14	90S/B5 90S/B14	90L/B5 90L/B14	100L/B5 100L/B14
k	1084.5	1107.5	1148.5	1148.5	1201
k1	1175.5	1200.5	1252	1252	1309.5
n / n1	137 / 112	155 / 123	176 / 132	176 / 132	193 / 149
m1 (B5)	160	200	200	200	250
m1 (B14)	-	120	140	140	160

* " k1 " Ölçüsü frenli redüktörlere aittir.
Dimension " k1 " is for motors with brake.
Maße " k1 " ist für Bremsenmotoren.

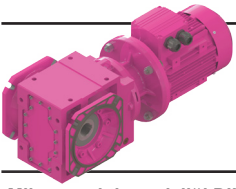

Ölçü Sayfaları Dimension Pages Abmessungsseiten



-Mil ucu çekirme deliği DIN 332 sayfa 2 / Tapped center hole to DIN 332, sheet 2 / Zentrierung mit Gewinde DIN 332, Blatt 2

KV775.08
KV776.08

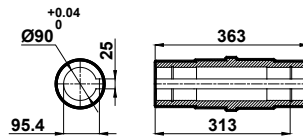
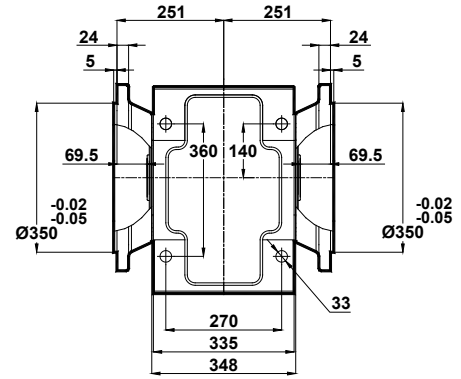
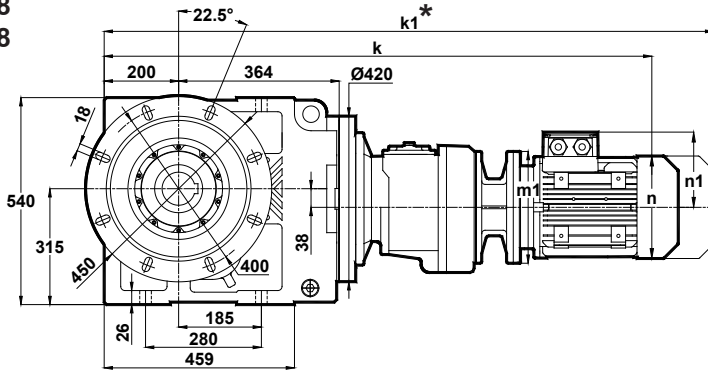

Klemens Pozisyonları
Terminal Box Positions
Klemmenkasten Positionen

	71/B5	80/B5 80/B14	90S/B5 90S/B14	90L/B5 90L/B14	100L/B5 100L/B14
k	1084.5	1107.5	1148.5	1148.5	1201
k1	1175.5	1200.5	1252	1252	1309.5
n / n1	137 / 112	155 / 123	176 / 132	176 / 132	193 / 149
m1 (B5)	160	200	200	200	250
m1 (B14)	-	120	140	140	160

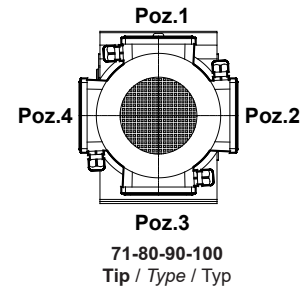

Opsiyonel flanş ölçüleri için sayfa 587'ye bakınız.
Please see on page 587 for optional flange dimensions
Siehe Seite 587 für auswählbare Flanschabmessungen

* " k1 " Ölçüsü frenli redüktörlere aittir.
Dimension " k1 " is for motors with brake.
Maße " k1 " ist für Bremsenmotoren.

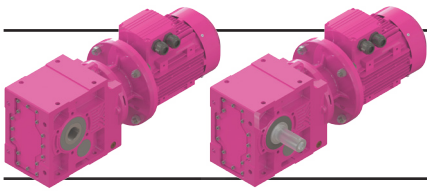

Ölçü Sayfaları

Dimension Pages

Abmessungsseiten

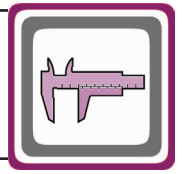

-Mil ucu çektirme deliği DIN 332 sayfa 2 / Tapped center hole to DIN 332, sheet 2 / Zentrierung mit Gewinde DIN 332, Blatt 2

KV873.00

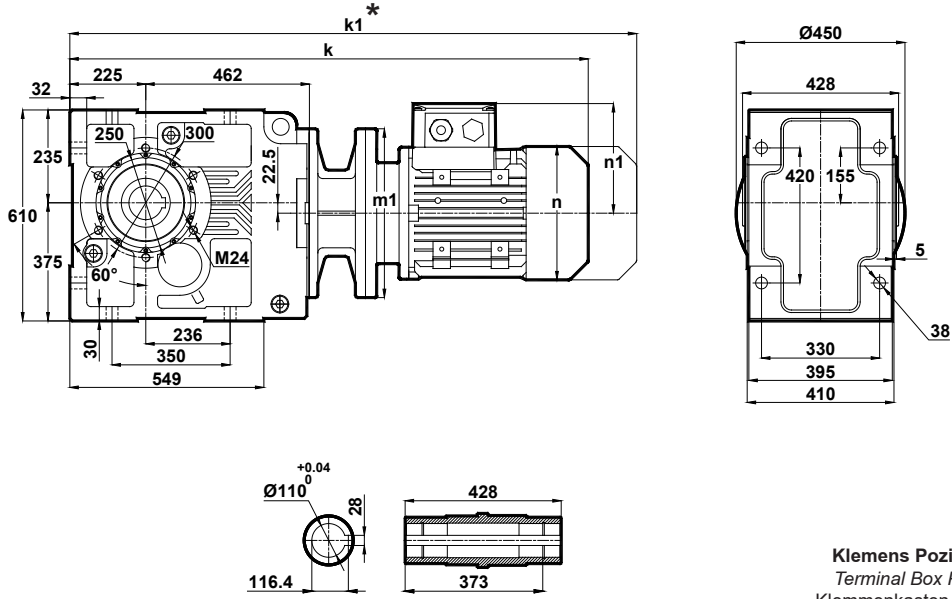

Klemens Pozisyonları
Terminal Box Positions
Klemmenkasten Positionen

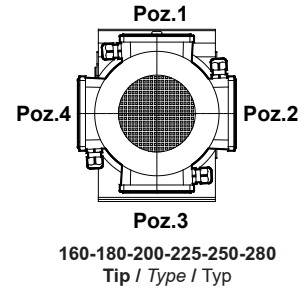

	160M/B5	160L/B5	180M/B5	180L/B5	200L/B5	225S/B5	225M/B5	250M/B5	280S/B5	280M/B5
k	1400	1400	1488	1488	1542	1560	1585	1661	1723	1723
k1	1548	1548	1646.5	1646.5	1728.5	1725	1750	1831.5	1896	1902
n / n1	316 / 224	316 / 224	348 / 250	348 / 250	396 / 287	438 / 315,5	438 / 315,5	481 / 335	544 / 350	544 / 350
m1 (B5)	350	350	350	350	400	450	450	550	550	550
m1 (B14)	-	-	-	-	-	-	-	-	-	-

KV873.01

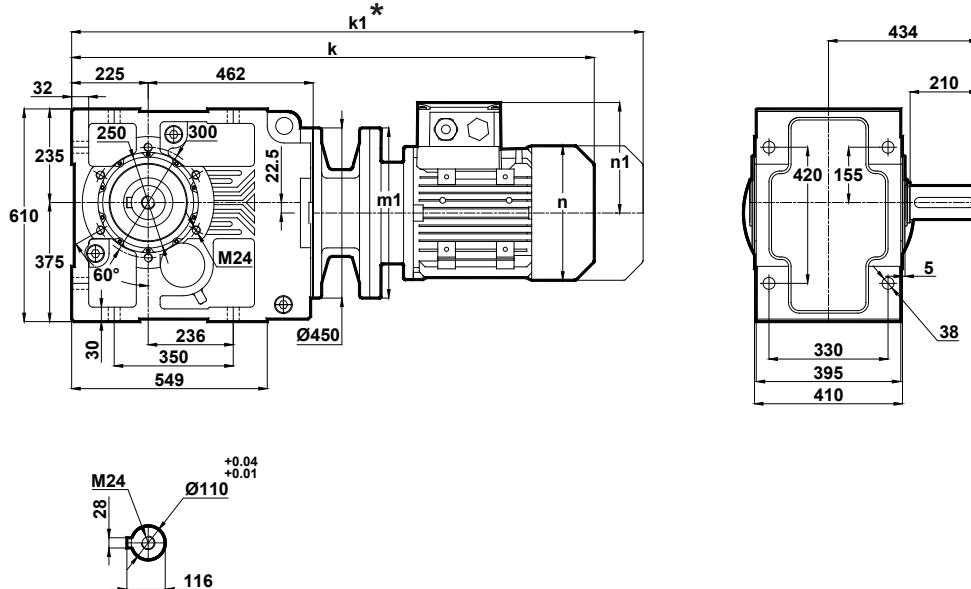

	160M/B5	160L/B5	180M/B5	180L/B5	200L/B5	225S/B5	225M/B5	250M/B5	280S/B5	280M/B5
k	1400	1400	1488	1488	1542	1560	1585	1661	1723	1723
k1	1548	1548	1646.5	1646.5	1728.5	1725	1750	1831.5	1896	1902
n / n1	316 / 224	316 / 224	348 / 250	348 / 250	396 / 287	438 / 315,5	438 / 315,5	481 / 335	544 / 350	544 / 350
m1 (B5)	350	350	350	350	400	450	450	550	550	550
m1 (B14)	-	-	-	-	-	-	-	-	-	-

* " k1 " Ölçüsü frenli redüktörlere aittir.
Dimension " k1 " is for motors with brake.
Maße " k1 " ist für Bremsenmotoren.

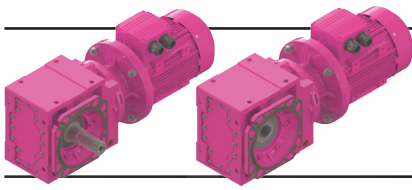

Ölçü Sayfaları

Dimension Pages

Abmessungsseiten

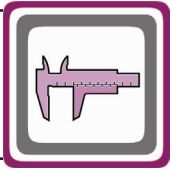

-Mil ucu çektirme deliği DIN 332 sayfa 2 / Tapped center hole to DIN 332, sheet 2 / Zentrierung mit Gewinde DIN 332, Blatt 2

KV873.02

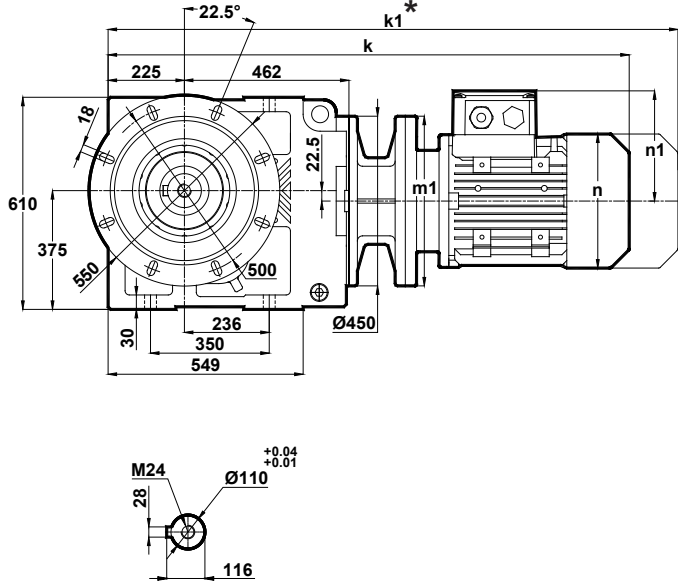

Klemens Pozisyonları
Terminal Box Positions
Klemmenkasten Positionen

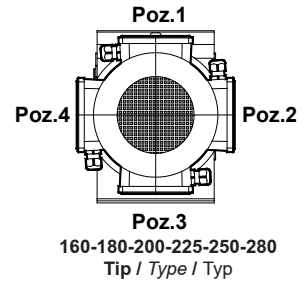

	160M/B5	160L/B5	180M/B5	180L/B5	200L/B5	225S/B5	225M/B5	250M/B5	280S/B5	280M/B5
k	1400	1400	1488	1488	1542	1560	1585	1661	1723	1723
k1	1548	1548	1646.5	1646.5	1728.5	1725	1750	1831.5	1896	1902
n / n1	316 / 224	316 / 224	348 / 250	348 / 250	396 / 287	438 / 315,5	438 / 315,5	481 / 335	544 / 350	544 / 350
m1 (B5)	350	350	350	350	400	450	450	550	550	550
m1 (B14)	-	-	-	-	-	-	-	-	-	-

Opsiyonel flanş ölçüleri için sayfa 587'ye bakınız.
Please see on page 587 for optional flange dimensions
Siehe Seite 587 für auswählbare Flanschabmessungen

KV873.03

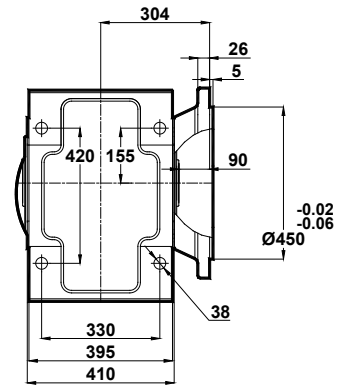
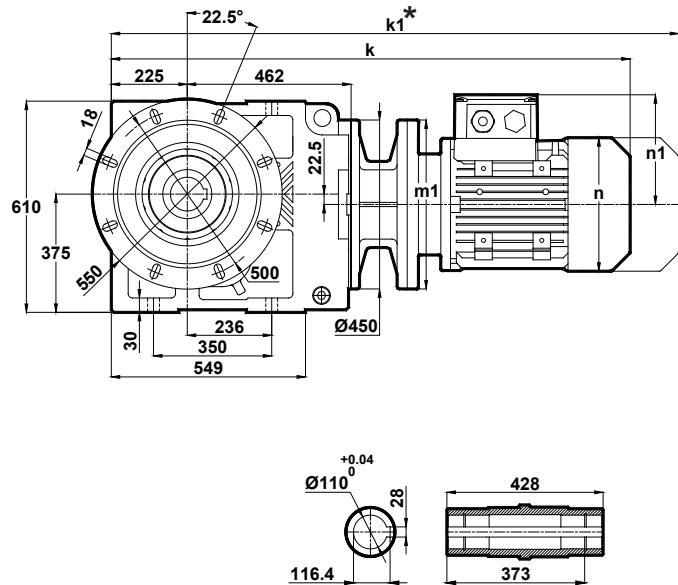

Opsiyonel flanş ölçüleri için sayfa 587'ye bakınız.
Please see on page 587 for optional flange dimensions
Siehe Seite 587 für auswählbare Flanschabmessungen

	160M/B5	160L/B5	180M/B5	180L/B5	200L/B5	225S/B5	225M/B5	250M/B5	280S/B5	280M/B5
k	1400	1400	1488	1488	1542	1560	1585	1661	1723	1723
k1	1548	1548	1646.5	1646.5	1728.5	1725	1750	1831.5	1896	1902
n / n1	316 / 224	316 / 224	348 / 250	348 / 250	396 / 287	438 / 315,5	438 / 315,5	481 / 335	544 / 350	544 / 350
m1 (B5)	350	350	350	350	400	450	450	550	550	550
m1 (B14)	-	-	-	-	-	-	-	-	-	-

* " k1 " Ölçüsü frenli redüktörlere aittir.
Dimension " k1 " is for motors with brake.
Maße " k1 " ist für Bremsenmotoren.

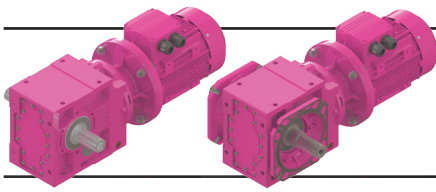

Ölçü Sayfaları

Dimension Pages

Abmessungsseiten

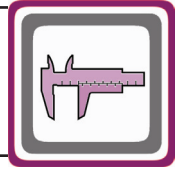

-Mil ucu çektirme deliği DIN 332 sayfa 2 / Tapped center hole to DIN 332, sheet 2 / Zentrierung mit Gewinde DIN 332, Blatt 2

KV873.04

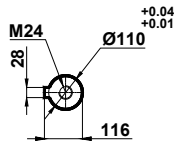
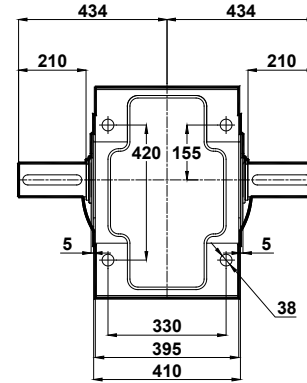
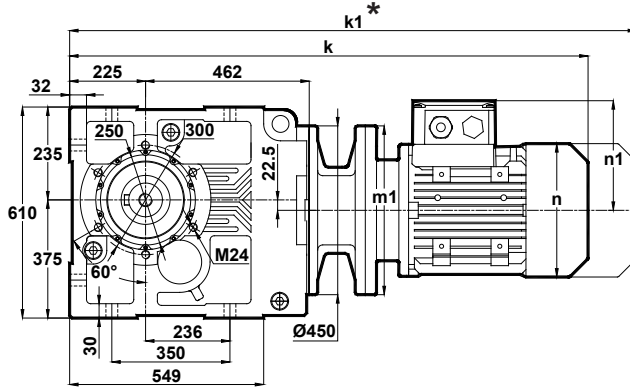

Klemens Pozisyonları
Terminal Box Positions
Klemmenkasten Positionen

	160M/B5	160L/B5	180M/B5	180L/B5	200L/B5	225S/B5	225M/B5	250M/B5	280S/B5	280M/B5
k	1400	1400	1488	1488	1542	1560	1585	1661	1723	1723
k1	1548	1548	1646.5	1646.5	1728.5	1725	1750	1831.5	1896	1902
n / n1	316 / 224	316 / 224	348 / 250	348 / 250	396 / 287	438 / 315,5	438 / 315,5	481 / 335	544 / 350	544 / 350
m1 (B5)	350	350	350	350	400	450	450	550	550	550
m1 (B14)	-	-	-	-	-	-	-	-	-	-

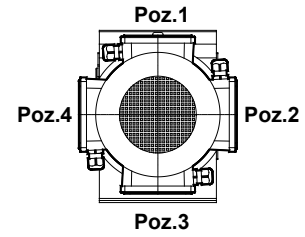

160-180-200-225-250-280
Tip / Type / Typ

KV873.05

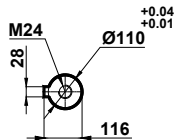
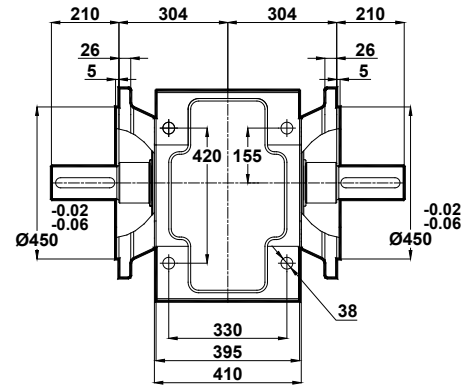
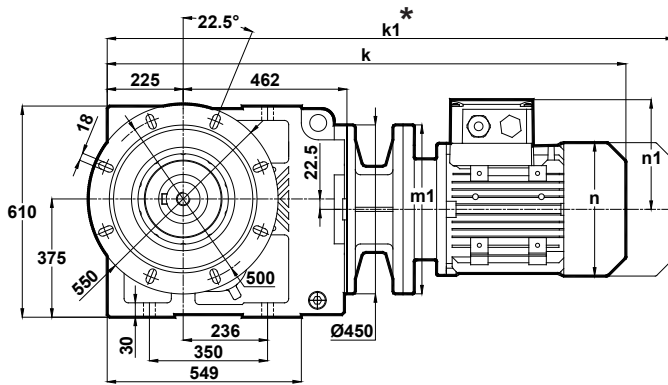

Opsiyonel flanş ölçüleri için sayfa 587'ye bakınız.
Please see on page 587 for optional flange dimensions
Siehe Seite 587 für auswählbare Flanschabmessungen

	160M/B5	160L/B5	180M/B5	180L/B5	200L/B5	225S/B5	225M/B5	250M/B5	280S/B5	280M/B5
k	1400	1400	1488	1488	1542	1560	1585	1661	1723	1723
k1	1548	1548	1646.5	1646.5	1728.5	1725	1750	1831.5	1896	1902
n / n1	316 / 224	316 / 224	348 / 250	348 / 250	396 / 287	438 / 315,5	438 / 315,5	481 / 335	544 / 350	544 / 350
m1 (B5)	350	350	350	350	400	450	450	550	550	550
m1 (B14)	-	-	-	-	-	-	-	-	-	-

* " k1 " Ölçüsü frenli redüktörlere aittir.
Dimension " k1 " is for motors with brake.
Maße " k1 " ist für Bremsenmotoren.

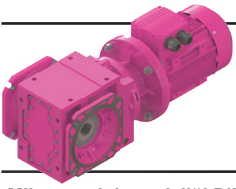

Ölçü Sayfaları Dimension Pages Abmessungsseiten

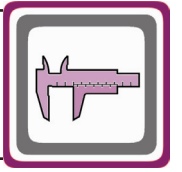

-Mil ucu çektirme deliği DIN 332 sayfa 2 / Tapped center hole to DIN 332, sheet 2 / Zentrierung mit Gewinde DIN 332, Blatt 2

KV873.08

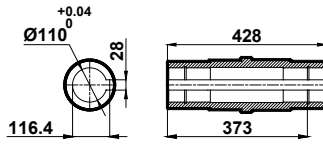
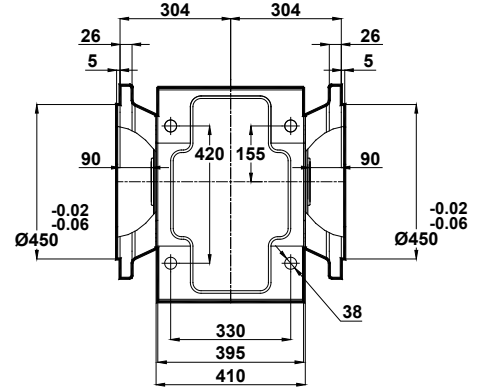
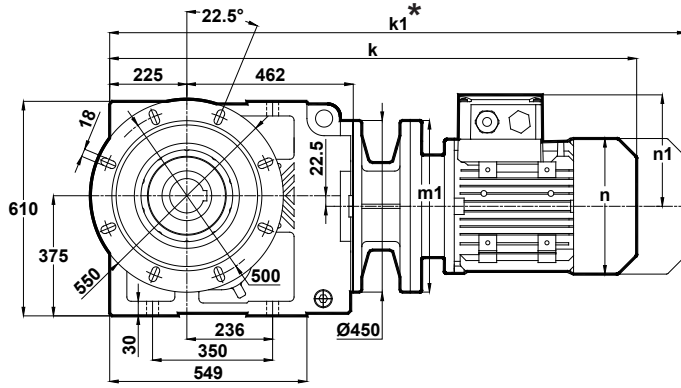

Klemens Pozisyonları
Terminal Box Positions
Klemmenkasten Positionen

	160M/B5	160L/B5	180M/B5	180L/B5	200L/B5	225S/B5	225M/B5	250M/B5	280S/B5	280M/B5
k	1400	1400	1488	1488	1542	1560	1585	1661	1723	1723
k1	1548	1548	1646.5	1646.5	1728.5	1725	1750	1831.5	1896	1902
n / n1	316 / 224	316 / 224	348 / 250	348 / 250	396 / 287	438 / 315,5	438 / 315,5	481 / 335	544 / 350	544 / 350
m1 (B5)	350	350	350	350	400	450	450	550	550	550
m1 (B14)	-	-	-	-	-	-	-	-	-	-

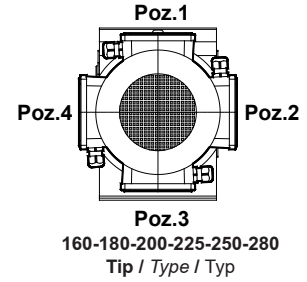

Opsiyonel flanş ölçüleri için sayfa 587'ye bakınız.
Please see on page 587 for optional flange dimensions
Siehe Seite 587 für auswählbare Flanschabmessungen

* " k1 " Ölçüsü frenli redüktörlere aittir.
Dimension " k1 " is for motors with brake.
Maße " k1 " ist für Bremsenmotoren.

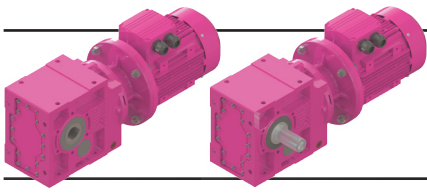

Ölçü Sayfaları

Dimension Pages

Abmessungsseiten

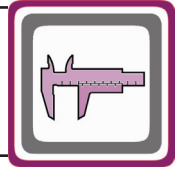

-Mil ucu çektirme deliği DIN 332 sayfa 2 / Tapped center hole to DIN 332, sheet 2 / Zentrierung mit Gewinde DIN 332, Blatt 2

KV874.00

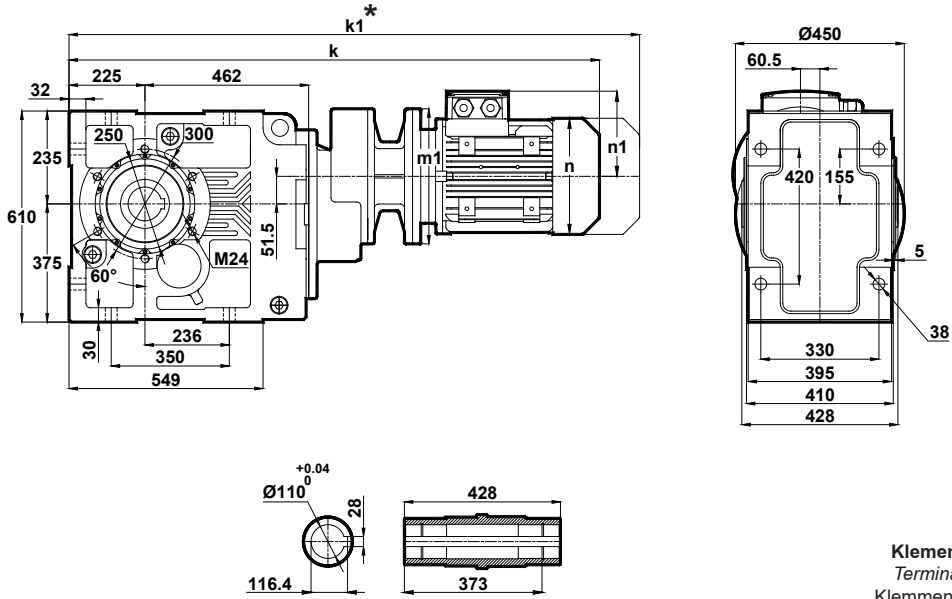

	100L/B5	112M/B5	132S/B5 132S/B14	132M/B5 132M/B14	160M/B5	160L/B5	180M/B5
k	1188	1208.5	1313.5	1313.5	1469	1469	1557
k1	1296.5	1313	1443.5	1443.5	1617	1617	1715.5
n / n1	193 / 149	215 / 161	257 / 181	257 / 181	316 / 224	316 / 224	348 / 250
m1 (B5)	250	250	300	300	350	350	350
m1 (B14)	-	-	200	200	-	-	-

Klemens Pozisyonları
Terminal Box Positions
Klemmenkasten Positionen

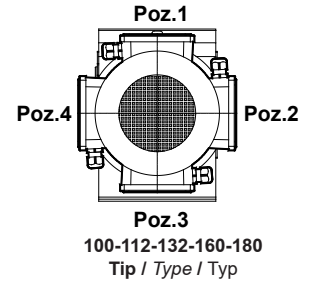

KV874.01

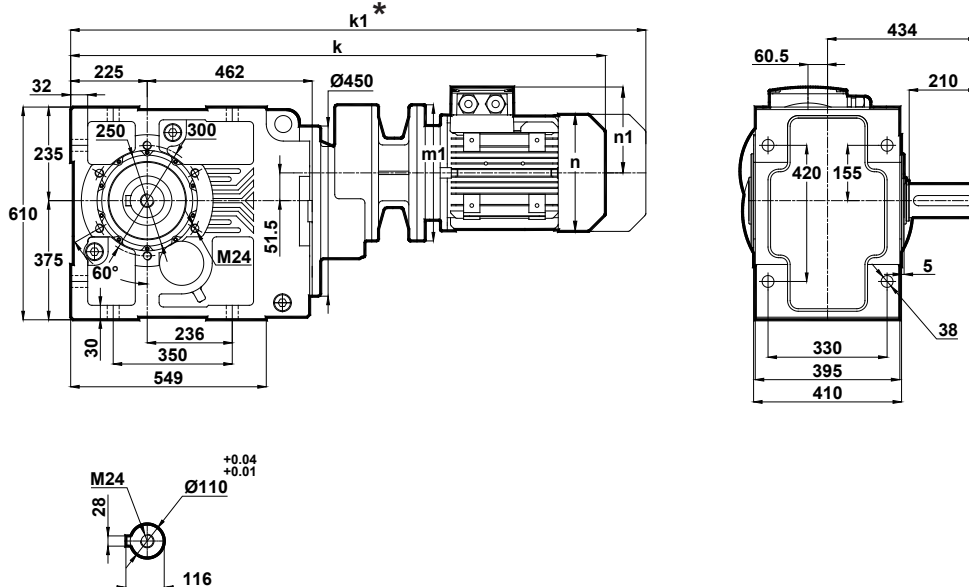

	100L/B5	112M/B5	132S/B5 132S/B14	132M/B5 132M/B14	160M/B5	160L/B5	180M/B5
k	1188	1208.5	1313.5	1313.5	1469	1469	1557
k1	1296.5	1313	1443.5	1443.5	1617	1617	1715.5
n / n1	193 / 149	215 / 161	257 / 181	257 / 181	316 / 224	316 / 224	348 / 250
m1 (B5)	250	250	300	300	350	350	350
m1 (B14)	-	-	200	200	-	-	-

* " k1 " Ölçüsü frenli redüktörlere aittir.
Dimension " k1 " is for motors with brake.
Maße " k1 " ist für Bremsenmotoren.

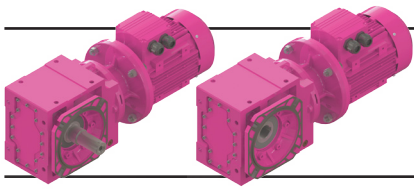

Ölçü Sayfaları Dimension Pages Abmessungsseiten



-Mil ucu çektirme deliği DIN 332 sayfa 2 / Tapped center hole to DIN 332, sheet 2 / Zentrierung mit Gewinde DIN 332, Blatt 2

KV874.02

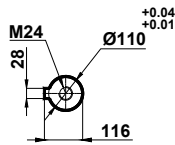
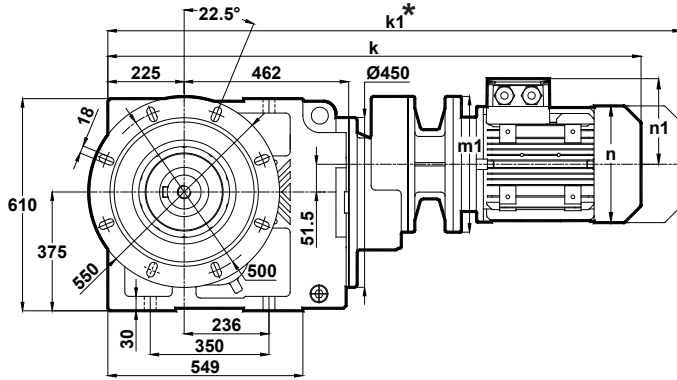

	100L/B5	112M/B5	132S/B5 132S/B14	132M/B5 132M/B14	160M/B5	160L/B5	180M/B5
k	1188	1208.5	1313.5	1313.5	1469	1469	1557
k1	1296.5	1313	1443.5	1443.5	1617	1617	1715.5
n / n1	193 / 149	215 / 161	257 / 181	257 / 181	316 / 224	316 / 224	348 / 250
m1 (B5)	250	250	300	300	350	350	350
m1 (B14)	-	-	200	200	-	-	-

Klemens Pozisyonları
Terminal Box Positions
Klemmenkasten Positionen

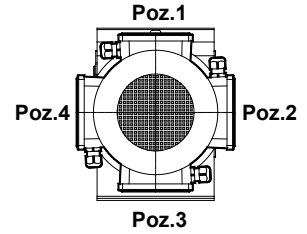

100-112-132-160-180
Tip / Type / Typ

Opsiyonel flanş ölçüleri için sayfa 587'ye bakınız.
Please see on page 587 for optional flange dimensions
Siehe Seite 587 für auswählbare Flanschabmessungen

KV874.03

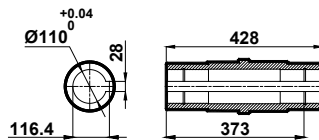
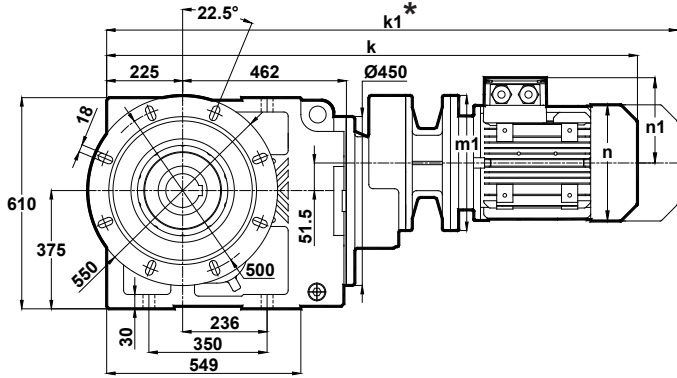

	100L/B5	112M/B5	132S/B5 132S/B14	132M/B5 132M/B14	160M/B5	160L/B5	180M/B5
k	1188	1208.5	1313.5	1313.5	1469	1469	1557
k1	1296.5	1313	1443.5	1443.5	1617	1617	1715.5
n / n1	193 / 149	215 / 161	257 / 181	257 / 181	316 / 224	316 / 224	348 / 250
m1 (B5)	250	250	300	300	350	350	350
m1 (B14)	-	-	200	200	-	-	-

Opsiyonel flanş ölçüleri için sayfa 587'ye bakınız.
Please see on page 587 for optional flange dimensions
Siehe Seite 587 für auswählbare Flanschabmessungen

* " k1 " Ölçüsü frenli redüktörlere aittir.
Dimension " k1 " is for motors with brake.
Maße " k1 " ist für Bremsenmotoren.

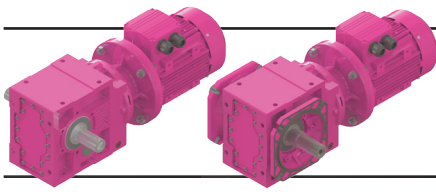

Ölçü Sayfaları

Dimension Pages

Abmessungsseiten

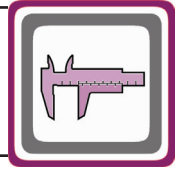

-Mil ucu çekirme deliği DIN 332 sayfa 2 / Tapped center hole to DIN 332, sheet 2 / Zentrierung mit Gewinde DIN 332, Blatt 2

KV874.04

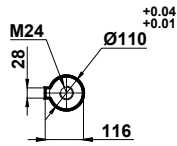
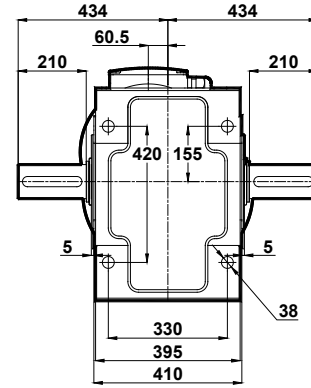
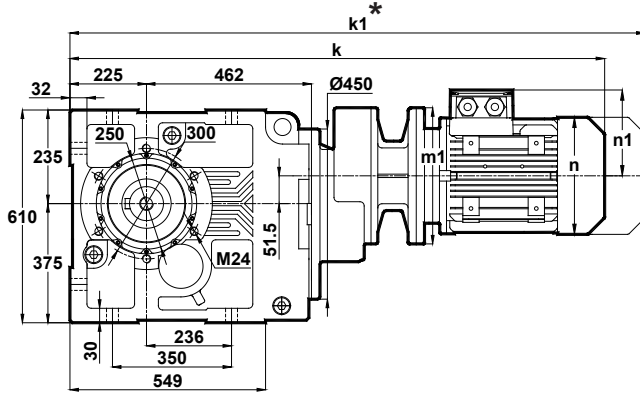

	100L/B5	112M/B5	132S/B5 132S/B14	132M/B5 132M/B14	160M/B5	160L/B5	180M/B5
k	1188	1208.5	1313.5	1313.5	1469	1469	1557
k1	1296.5	1313	1443.5	1443.5	1617	1617	1715.5
n / n1	193 / 149	215 / 161	257 / 181	257 / 181	316 / 224	316 / 224	348 / 250
m1 (B5)	250	250	300	300	350	350	350
m1 (B14)	-	-	200	200	-	-	-

Klemens Pozisyonları
Terminal Box Positions
Klemmenkasten Positionen

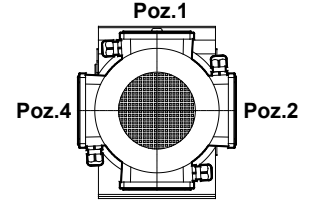

Poz.3

100-112-132-160-180
Tip / Type / Typ

KV874.05

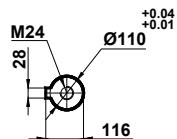
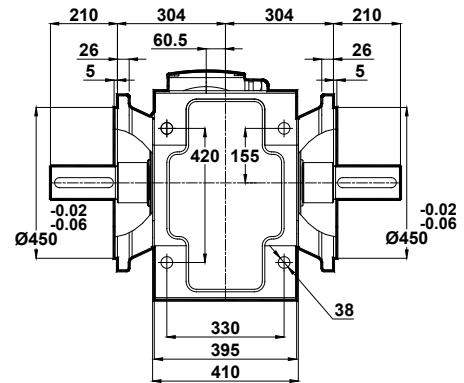
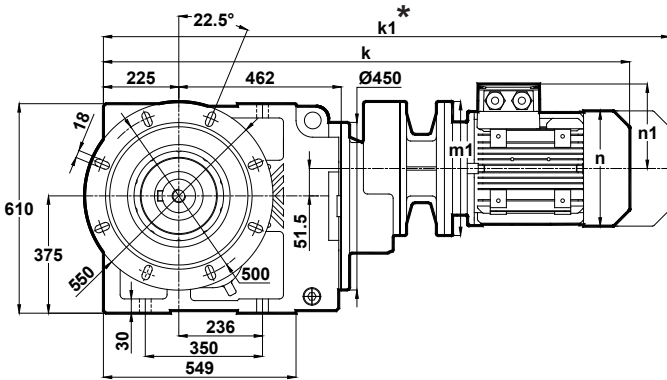

	100L/B5	112M/B5	132S/B5 132S/B14	132M/B5 132M/B14	160M/B5	160L/B5	180M/B5
k	1188	1208.5	1313.5	1313.5	1469	1469	1557
k1	1296.5	1313	1443.5	1443.5	1617	1617	1715.5
n / n1	193 / 149	215 / 161	257 / 181	257 / 181	316 / 224	316 / 224	348 / 250
m1 (B5)	250	250	300	300	350	350	350
m1 (B14)	-	-	200	200	-	-	-

Opsiyonel flanş ölçüleri için sayfa 587'ye bakınız.
Please see on page 587 for optional flange dimensions
Siehe Seite 587 für auswählbare Flanschabmessungen

* "k1" Ölçüsü frenli redüktörlere aittir.
Dimension "k1" is for motors with brake.
Maße "k1" ist für Bremsenmotoren.

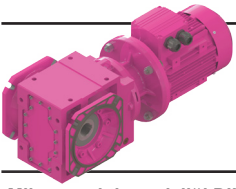

Ölçü Sayfaları Dimension Pages Abmessungsseiten



-Mil ucu çektirme deliği DIN 332 sayfa 2 / Tapped center hole to DIN 332, sheet 2 / Zentrierung mit Gewinde DIN 332, Blatt 2

KV874.08

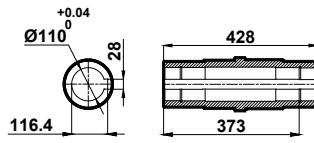
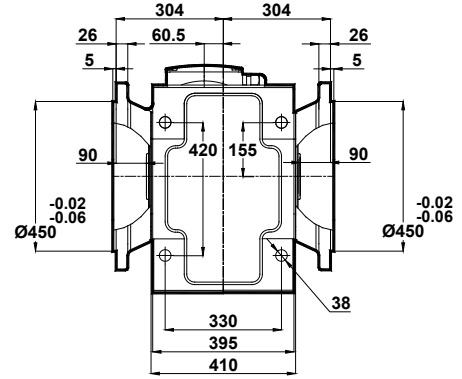
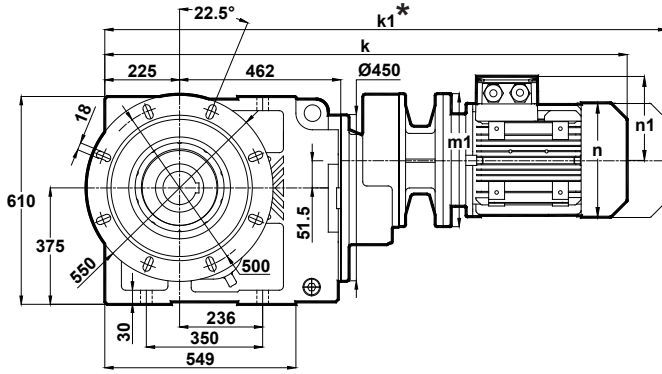

Klemens Pozisyonları
Terminal Box Positions
Klemmenkasten Positionen

	100L/B5	112M/B5	132S/B5 132S/B14	132M/B5 132M/B14	160M/B5	160L/B5	180M/B5
k	1188	1208.5	1313.5	1313.5	1469	1469	1557
k1	1296.5	1313	1443.5	1443.5	1617	1617	1715.5
n / n1	193 / 149	215 / 161	257 / 181	257 / 181	316 / 224	316 / 224	348 / 250
m1 (B5)	250	250	300	300	350	350	350
m1 (B14)	-	-	200	200	-	-	-

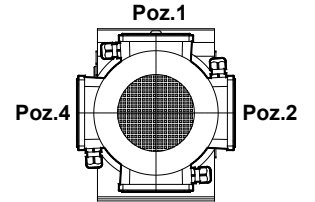

Poz.3
100-112-132-160-180
Tip / Type / Typ

Opsiyonel flanş ölçüleri için sayfa 587'ye bakınız.
Please see on page 587 for optional flange dimensions
Siehe Seite 587 für auswählbare Flanschabmessungen

* " k1 " Ölçüsü frenli redüktörlere aittir.
Dimension " k1 " is for motors with brake.
Maße " k1 " ist für Bremsenmotoren.

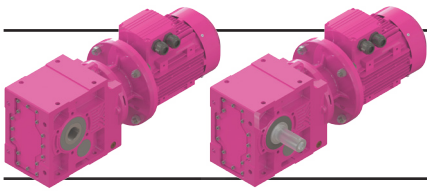

Ölçü Sayfaları

Dimension Pages

Abmessungsseiten

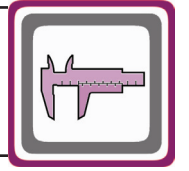

-Mil ucu çektirme deliği DIN 332 sayfa 2 / Tapped center hole to DIN 332, sheet 2 / Zentrierung mit Gewinde DIN 332, Blatt 2

KV875.00
KV876.00

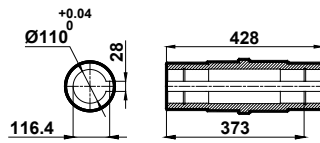
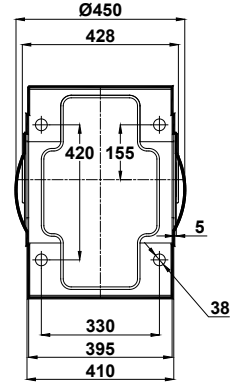
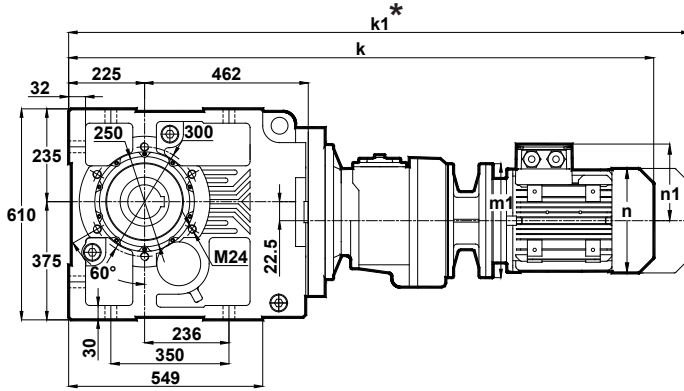

Klemens Pozisyonları
Terminal Box Positions
Klemmenkasten Positionen

	71/B5	80/B5 80/B14	90S/B5 90S/B14	90L/B5 90L/B14	100L/B5 100L/B14	112M/B5 112M/B14
k	1207.5	1230.5	1271.5	1271.5	1324	1344.5
k1	1298.5	1323.5	1375	1375	1432.5	1449
n / n1	137 / 112	155 / 123	176 / 132	176 / 132	193 / 149	215 / 161
m1 (B5)	160	200	200	200	250	250
m1 (B14)	-	120	140	140	160	160

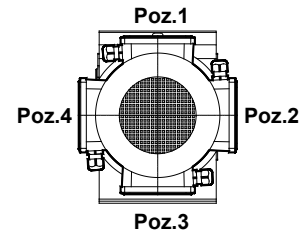

71-80-90-100-112
Tip / Type / Typ

KV875.01
KV876.01

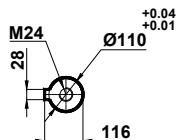
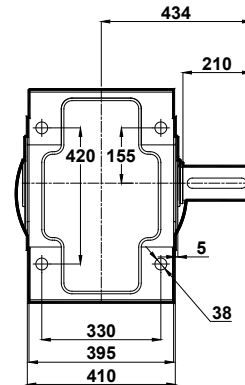
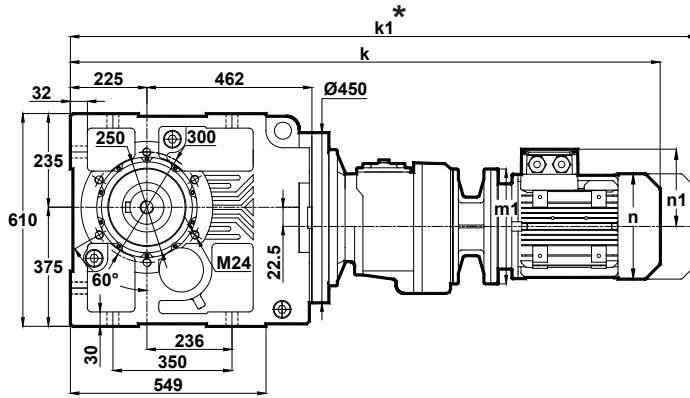

	71/B5	80/B5 80/B14	90S/B5 90S/B14	90L/B5 90L/B14	100L/B5 100L/B14	112M/B5 112M/B14
k	1207.5	1230.5	1271.5	1271.5	1324	1344.5
k1	1298.5	1323.5	1375	1375	1432.5	1449
n / n1	137 / 112	155 / 123	176 / 132	176 / 132	193 / 149	215 / 161
m1 (B5)	160	200	200	200	250	250
m1 (B14)	-	120	140	140	160	160

* " k1 " Ölçüsü frenli redüktörlere aittir.
Dimension " k1 " is for motors with brake.
Maße " k1 " ist für Bremsenmotoren.

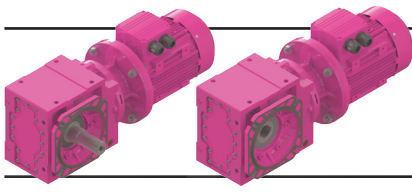

Ölçü Sayfaları Dimension Pages Abmessungsseiten

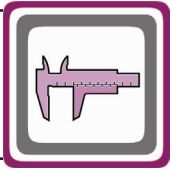

-Mil ucu çekirme deliği DIN 332 sayfa 2 / Tapped center hole to DIN 332, sheet 2 / Zentrierung mit Gewinde DIN 332, Blatt 2

KV875.02
KV876.02

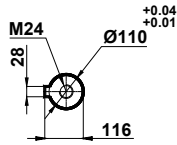
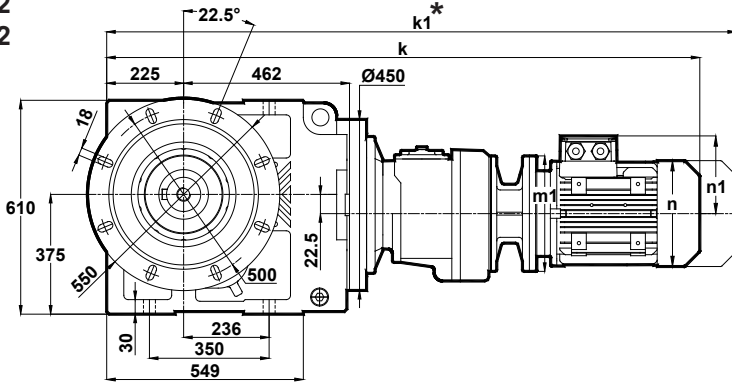

	71/B5	80/B5 80/B14	90S/B5 90S/B14	90L/B5 90L/B14	100L/B5 100L/B14	112M/B5 112M/B14
k	1207.5	1230.5	1271.5	1271.5	1324	1344.5
k1	1298.5	1323.5	1375	1375	1432.5	1449
n / n1	137 / 112	155 / 123	176 / 132	176 / 132	193 / 149	215 / 161
m1 (B5)	160	200	200	200	250	250
m1 (B14)	-	120	140	140	160	160

Klemens Pozisyonları
Terminal Box Positions
Klemmenkasten Positionen

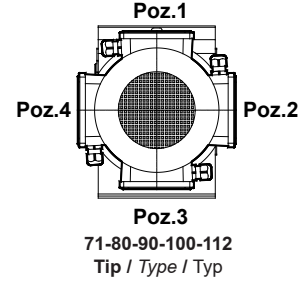

Opsiyonel flanş ölçüleri için sayfa 587'ye bakınız.
Please see on page 587 for optional flange dimensions
Siehe Seite 587 für auswählbare Flanschabmessungen

KV875.03
KV876.03

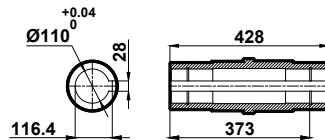
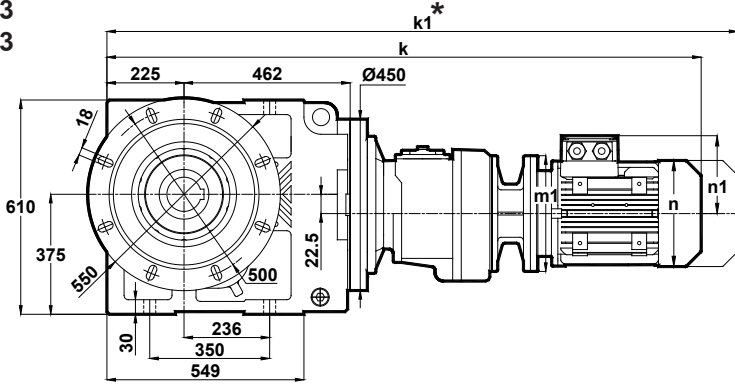

	71/B5	80/B5 80/B14	90S/B5 90S/B14	90L/B5 90L/B14	100L/B5 100L/B14	112M/B5 112M/B14
k	1207.5	1230.5	1271.5	1271.5	1324	1344.5
k1	1298.5	1323.5	1375	1375	1432.5	1449
n / n1	137 / 112	155 / 123	176 / 132	176 / 132	193 / 149	215 / 161
m1 (B5)	160	200	200	200	250	250
m1 (B14)	-	120	140	140	160	160

Opsiyonel flanş ölçüleri için sayfa 587'ye bakınız.
Please see on page 587 for optional flange dimensions
Siehe Seite 587 für auswählbare Flanschabmessungen

* "k1" Ölçüsü frenli redüktörlere aittir.
Dimension "k1" is for motors with brake.
Maße "k1" ist für Bremsenmotoren.

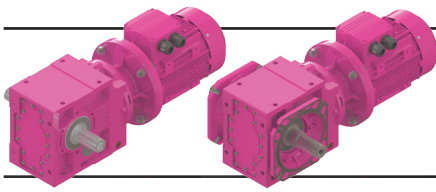

Ölçü Sayfaları

Dimension Pages

Abmessungsseiten

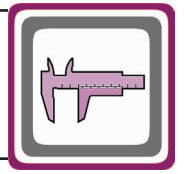

-Mil ucu çektirme deliği DIN 332 sayfa 2 / Tapped center hole to DIN 332, sheet 2 / Zentrierung mit Gewinde DIN 332, Blatt 2

KV875.04
KV876.04

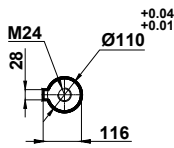
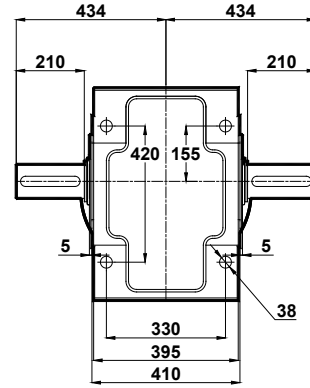
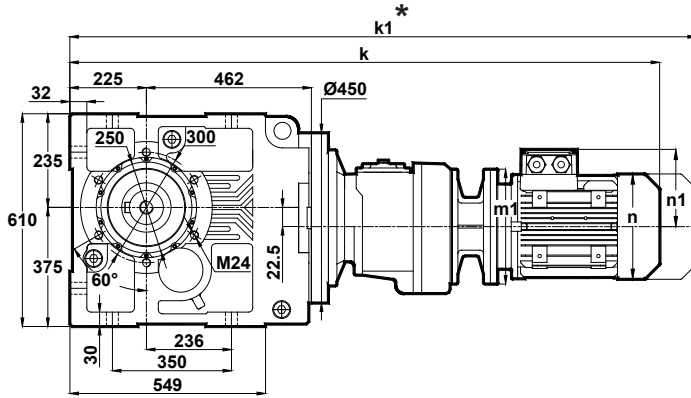

	71/B5	80/B5 80/B14	90S/B5 90S/B14	90L/B5 90L/B14	100L/B5 100L/B14	112M/B5 112M/B14
k	1207.5	1230.5	1271.5	1271.5	1324	1344.5
k1	1298.5	1323.5	1375	1375	1432.5	1449
n / n1	137 / 112	155 / 123	176 / 132	176 / 132	193 / 149	215 / 161
m1 (B5)	160	200	200	200	250	250
m1 (B14)	-	120	140	140	160	160

Klemens Pozisyonları
Terminal Box Positions
Klemmenkasten Positionen

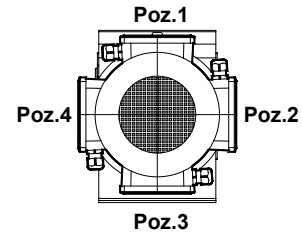

71-80-90-100-112
Tip / Type / Typ

KV875.05
KV876.05

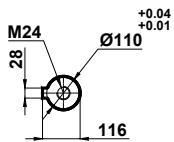
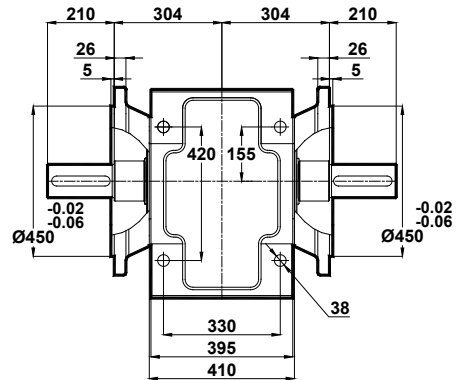
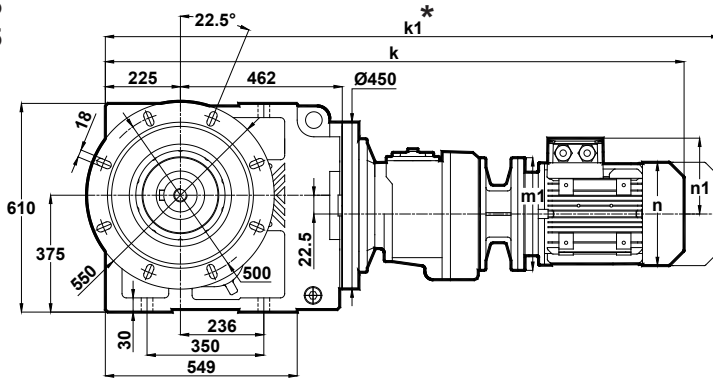

	71/B5	80/B5 80/B14	90S/B5 90S/B14	90L/B5 90L/B14	100L/B5 100L/B14	112M/B5 112M/B14
k	1207.5	1230.5	1271.5	1271.5	1324	1344.5
k1	1298.5	1323.5	1375	1375	1432.5	1449
n / n1	137 / 112	155 / 123	176 / 132	176 / 132	193 / 149	215 / 161
m1 (B5)	160	200	200	200	250	250
m1 (B14)	-	120	140	140	160	160

Opsiyonel flanş ölçüleri için sayfa 587'ye bakınız.
Please see on page 587 for optional flange dimensions
Siehe Seite 587 für auswählbare Flanschabmessungen

* " k1 " Ölçüsü frenli redüktörlere aittir.
Dimension " k1 " is for motors with brake.
Maße " k1 " ist für Bremsenmotoren.

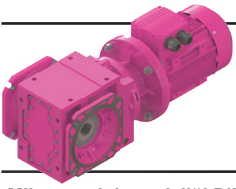

Ölçü Sayfaları Dimension Pages Abmessungsseiten

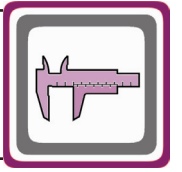

-Mil ucu çekirme deliği DIN 332 sayfa 2 / Tapped center hole to DIN 332, sheet 2 / Zentrierung mit Gewinde DIN 332, Blatt 2

KV875.08
KV876.08

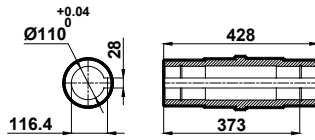
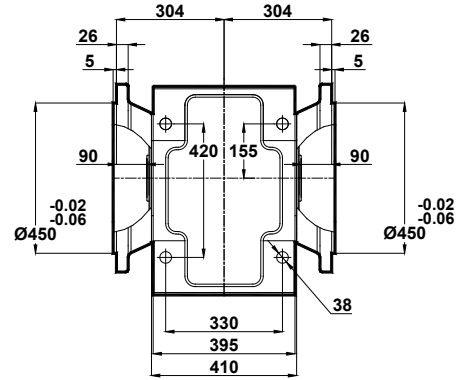
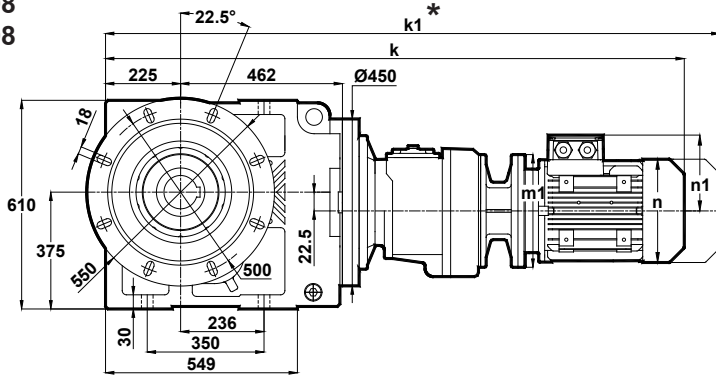

Klemens Pozisyonları
Terminal Box Positions
Klemmenkasten Positionen

	71/B5	80/B5 80/B14	90S/B5 90S/B14	90L/B5 90L/B14	100L/B5 100L/B14	112M/B5 112M/B14
k	1207.5	1230.5	1271.5	1271.5	1324	1344.5
k1	1298.5	1323.5	1375	1375	1432.5	1449
n / n1	137 / 112	155 / 123	176 / 132	176 / 132	193 / 149	215 / 161
m1 (B5)	160	200	200	200	250	250
m1 (B14)	-	120	140	140	160	160

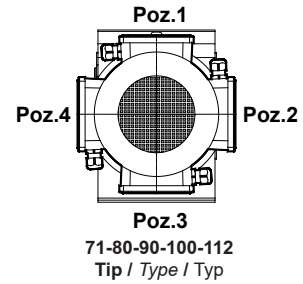

Opsiyonel flanş ölçüleri için sayfa 587'ye bakınız.
Please see on page 587 for optional flange dimensions
Siehe Seite 587 für auswählbare Flanschabmessungen

* " k1 " Ölçüsü frenli redüktörlere aittir.
Dimension " k1 " is for motors with brake.
Maße " k1 " ist für Bremsenmotoren.

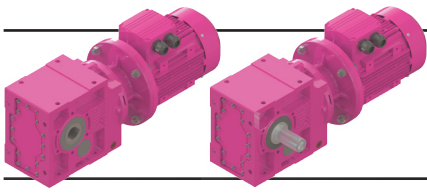

Ölçü Sayfaları Dimension Pages Abmessungsseiten

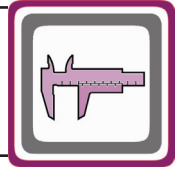

-Mil ucu çektirme deliği DIN 332 sayfa 2 / Tapped center hole to DIN 332, sheet 2 / Zentrierung mit Gewinde DIN 332, Blatt 2

KV973.00

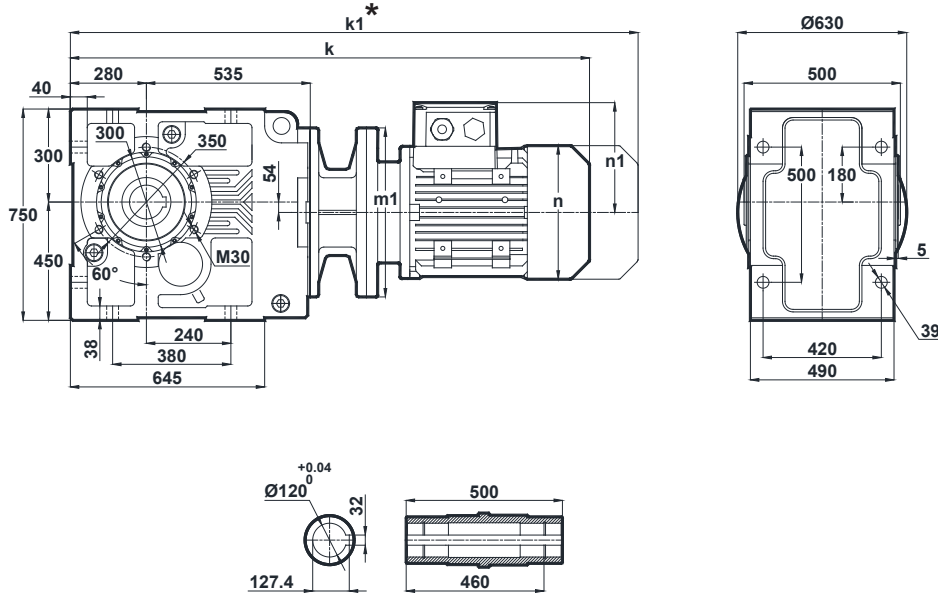

Klemens Pozisyonları
Terminal Box Positions
Klemmenkasten Positionen

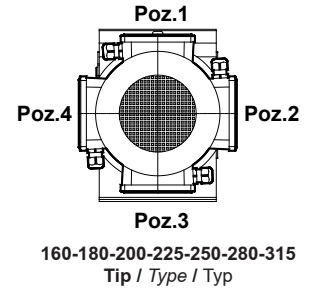

	160M/B5	160L/B5	180M/B5	180L/B5	200L/B5	225S/B5	225M/B5	250M/B5	280S/B5	280M/B5	315S/B5	315M/B5
k	1442	1442	1534	1534	1601	1698	1698	1791	1853	1853	2095	2095
k1	1590	1590	1692.5	1692.5	1783	1880.5	1880.5	1948.5	2051	2051	-	-
n / n1	316 / 224	316 / 224	348 / 250	348 / 250	396 / 287	438 / 316	438 / 316	481 / 335	547 / 402	547 / 402	614 / 510	614 / 510
m1 (B5)	350	350	350	350	400	450	450	550	550	550	660	660
m1 (B14)	-	-	-	-	-	-	-	-	-	-	-	-

KV973.01

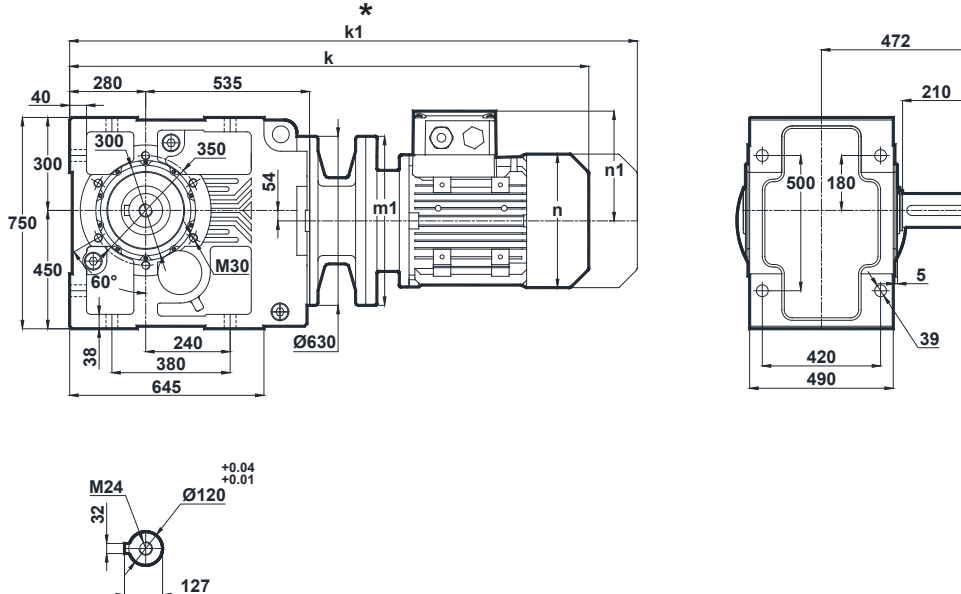

	160M/B5	160L/B5	180M/B5	180L/B5	200L/B5	225S/B5	225M/B5	250M/B5	280S/B5	280M/B5	315S/B5	315M/B5
k	1442	1442	1534	1534	1601	1698	1698	1791	1853	1853	2095	2095
k1	1590	1590	1692.5	1692.5	1783	1880.5	1880.5	1948.5	2051	2051	-	-
n / n1	316 / 224	316 / 224	348 / 250	348 / 250	396 / 287	438 / 316	438 / 316	481 / 335	547 / 402	547 / 402	614 / 510	614 / 510
m1 (B5)	350	350	350	350	400	450	450	550	550	550	660	660
m1 (B14)	-	-	-	-	-	-	-	-	-	-	-	-

* " k1 " Ölçüsü frenli redüktörlere aittir.
Dimension " k1 " is for motors with brake.
Maße " k1 " ist für Bremsenmotoren.

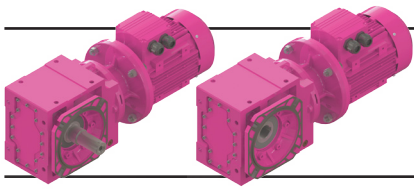

Ölçü Sayfaları

Dimension Pages

Abmessungsseiten



-Mil ucu çektirme deliği DIN 332 sayfa 2 / Tapped center hole to DIN 332, sheet 2 / Zentrierung mit Gewinde DIN 332, Blatt 2

KV973.02

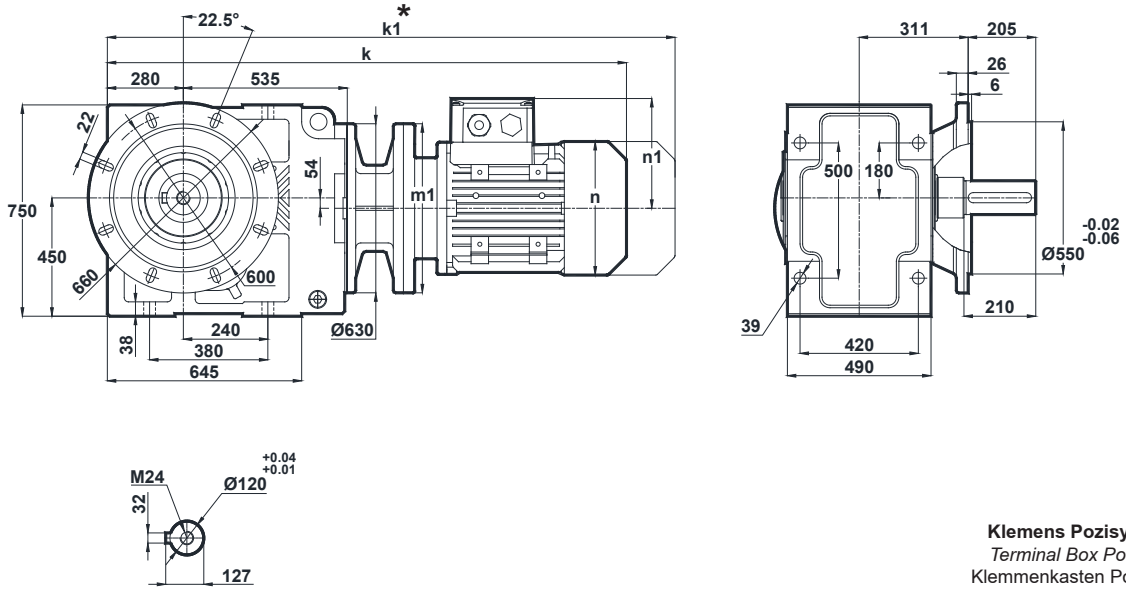

Klemens Pozisyonları
Terminal Box Positions
Klemmenkasten Positionen

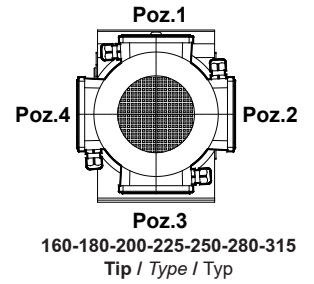

	160M/B5	160L/B5	180M/B5	180L/B5	200L/B5	225S/B5	225M/B5	250M/B5	280S/B5	280M/B5	315S/B5	315M/B5
k	1442	1442	1534	1534	1601	1698	1698	1791	1853	1853	2095	2095
k1	1590	1590	1692.5	1692.5	1783	1880.5	1880.5	1948.5	2051	2051	-	-
n / n1	316 / 224	316 / 224	348 / 250	348 / 250	396 / 287	438 / 316	438 / 316	481 / 335	547 / 402	547 / 402	614 / 510	614 / 510
m1 (B5)	350	350	350	350	400	450	450	550	550	550	660	660
m1 (B14)	-	-	-	-	-	-	-	-	-	-	-	-

KV973.03

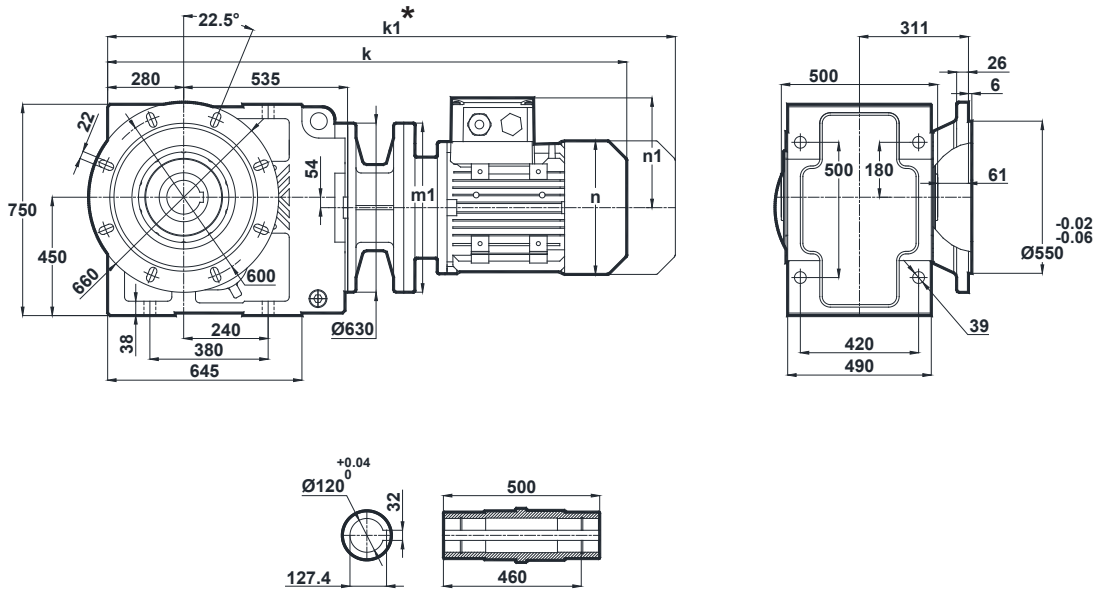

	160M/B5	160L/B5	180M/B5	180L/B5	200L/B5	225S/B5	225M/B5	250M/B5	280S/B5	280M/B5	315S/B5	315M/B5
k	1442	1442	1534	1534	1601	1698	1698	1791	1853	1853	2095	2095
k1	1590	1590	1692.5	1692.5	1783	1880.5	1880.5	1948.5	2051	2051	-	-
n / n1	316 / 224	316 / 224	348 / 250	348 / 250	396 / 287	438 / 316	438 / 316	481 / 335	547 / 402	547 / 402	614 / 510	614 / 510
m1 (B5)	350	350	350	350	400	450	450	550	550	550	660	660
m1 (B14)	-	-	-	-	-	-	-	-	-	-	-	-

* "k1" Ölçüsü frenli redüktörlere aittir.
Dimension "k1" is for motors with brake.
Maße "k1" ist für Bremsenmotoren.

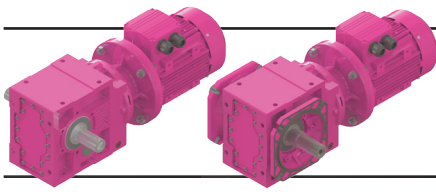

Ölçü Sayfaları

Dimension Pages

Abmessungsseiten

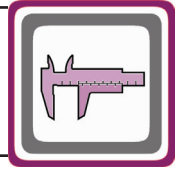

-Mil ucu çektirme deliği DIN 332 sayfa 2 / Tapped center hole to DIN 332, sheet 2 / Zentrierung mit Gewinde DIN 332, Blatt 2

KV973.04

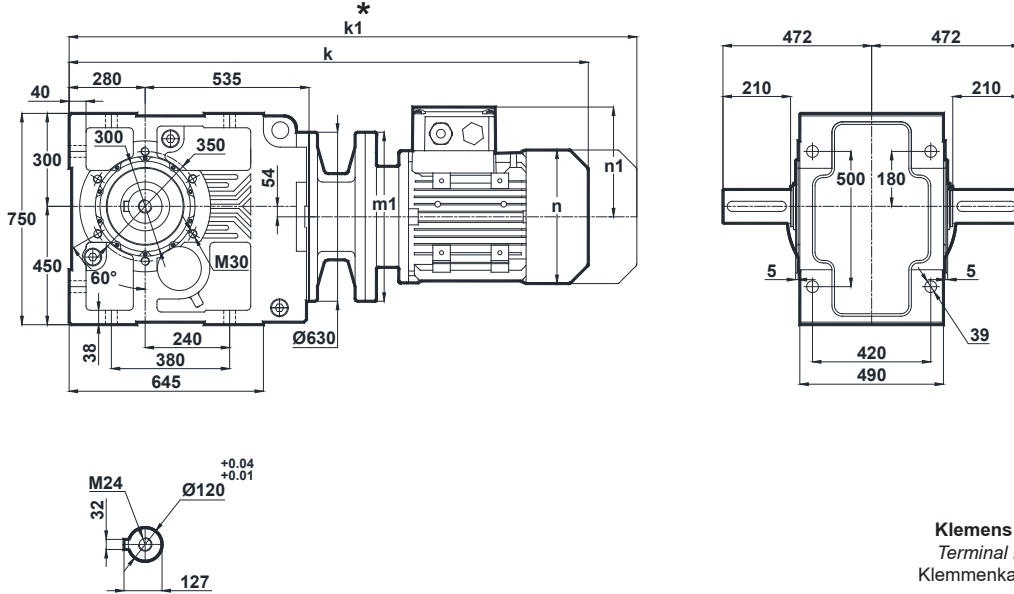

Klemens Pozisyonları
Terminal Box Positions
Klemmenkasten Positionen

	160M/B5	160L/B5	180M/B5	180L/B5	200L/B5	225S/B5	225M/B5	250M/B5	280S/B5	280M/B5	315S/B5	315M/B5
k	1442	1442	1534	1534	1601	1698	1698	1791	1853	1853	2095	2095
k1	1590	1590	1692.5	1692.5	1783	1880.5	1880.5	1948.5	2051	2051	-	-
n / n1	316 / 224	316 / 224	348 / 250	348 / 250	396 / 287	438 / 316	438 / 316	481 / 335	547 / 402	547 / 402	614 / 510	614 / 510
m1 (B5)	350	350	350	350	400	450	450	550	550	550	660	660
m1 (B14)	-	-	-	-	-	-	-	-	-	-	-	-

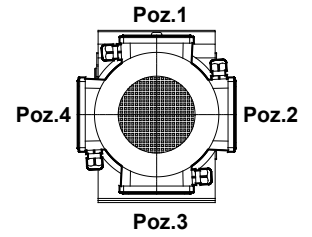

160-180-200-225-250-280-315
Tip / Type / Typ

KV973.05

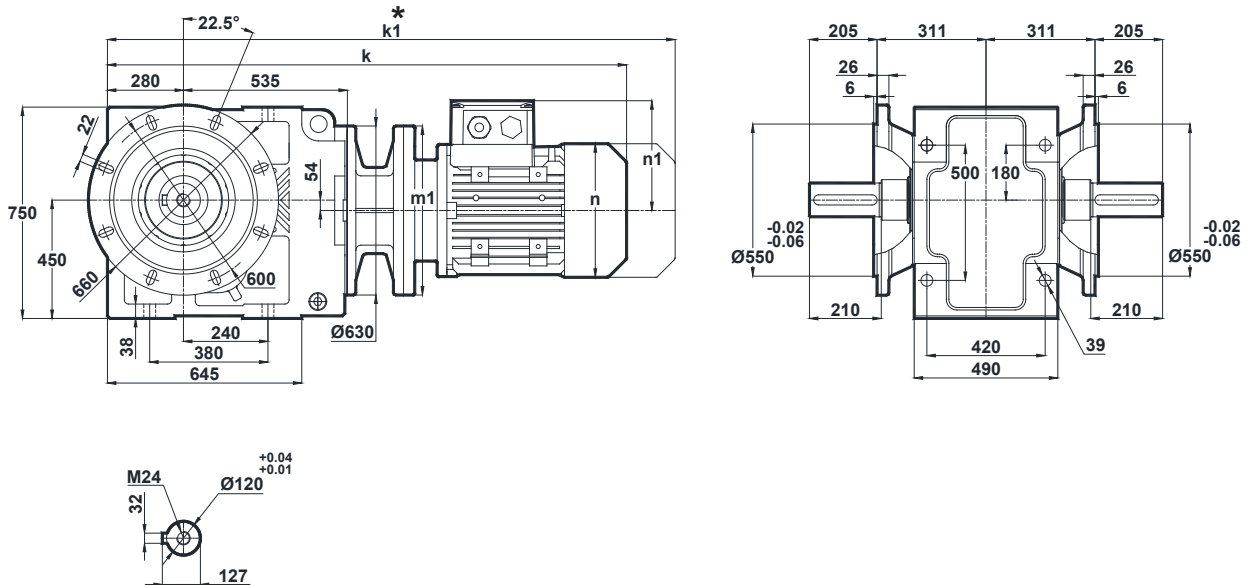

	160M/B5	160L/B5	180M/B5	180L/B5	200L/B5	225S/B5	225M/B5	250M/B5	280S/B5	280M/B5	315S/B5	315M/B5
k	1442	1442	1534	1534	1601	1698	1698	1791	1853	1853	2095	2095
k1	1590	1590	1692.5	1692.5	1783	1880.5	1880.5	1948.5	2051	2051	-	-
n / n1	316 / 224	316 / 224	354 / 240	354 / 240	399 / 285	438 / 314	438 / 314	481 / 335	544 / 350	544 / 350	614 / 510	614 / 510
m1 (B5)	350	350	350	350	400	450	450	550	550	550	660	660
m1 (B14)	-	-	-	-	-	-	-	-	-	-	-	-

* "k1" Ölçüsü frenli redüktörlere aittir.
Dimension "k1" is for motors with brake.
Maße "k1" ist für Bremsenmotoren.

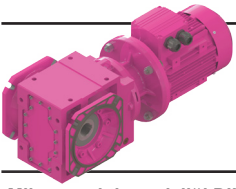

Ölçü Sayfaları Dimension Pages Abmessungsseiten



-Mil ucu çekirme deliği DIN 332 sayfa 2 / Tapped center hole to DIN 332, sheet 2 / Zentrierung mit Gewinde DIN 332, Blatt 2

KV973.08

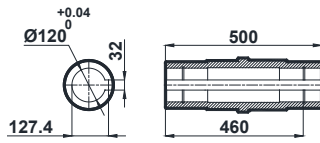
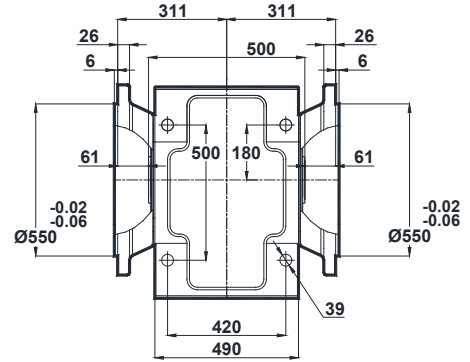
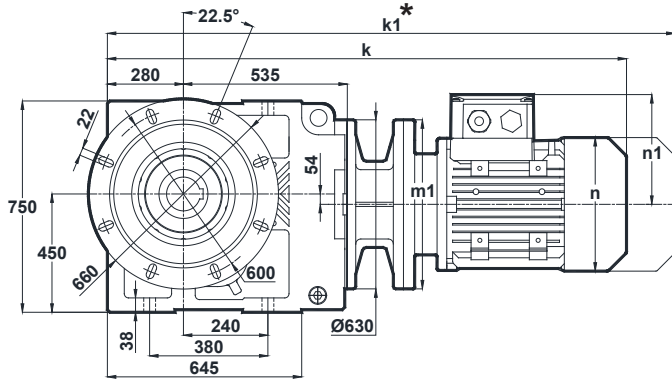

Klemens Pozisyonları
Terminal Box Positions
Klemmenkasten Positionen

	160M/B5	160L/B5	180M/B5	180L/B5	200L/B5	225S/B5	225M/B5	250M/B5	280S/B5	280M/B5	315S/B5	315M/B5
k	1442	1442	1534	1534	1601	1698	1698	1791	1853	1853	2095	2095
k1	1590	1590	1692.5	1692.5	1783	1880.5	1880.5	1948.5	2051	2051	-	-
n / n1	316 / 224	316 / 224	348 / 250	348 / 250	396 / 287	438 / 316	438 / 316	481 / 335	547 / 402	547 / 402	614 / 510	614 / 510
m1 (B5)	350	350	350	350	400	450	450	550	550	550	660	660
m1 (B14)	-	-	-	-	-	-	-	-	-	-	-	-

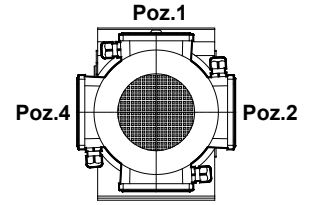

Poz.3
160-180-200-225-250-280-315
Tip / Type / Typ

* "k1" Ölçüsü frenli redüktörlere aittir.
Dimension "k1" is for motors with brake.
Maße "k1" ist für Bremsenmotoren.

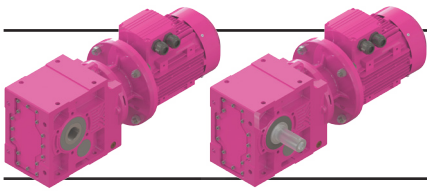

Ölçü Sayfaları Dimension Pages Abmessungenseiten

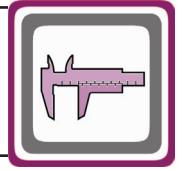

-Mil ucu çekirme deliği DIN 332 sayfa 2 / Tapped center hole to DIN 332, sheet 2 / Zentrierung mit Gewinde DIN 332, Blatt 2

KV974.00

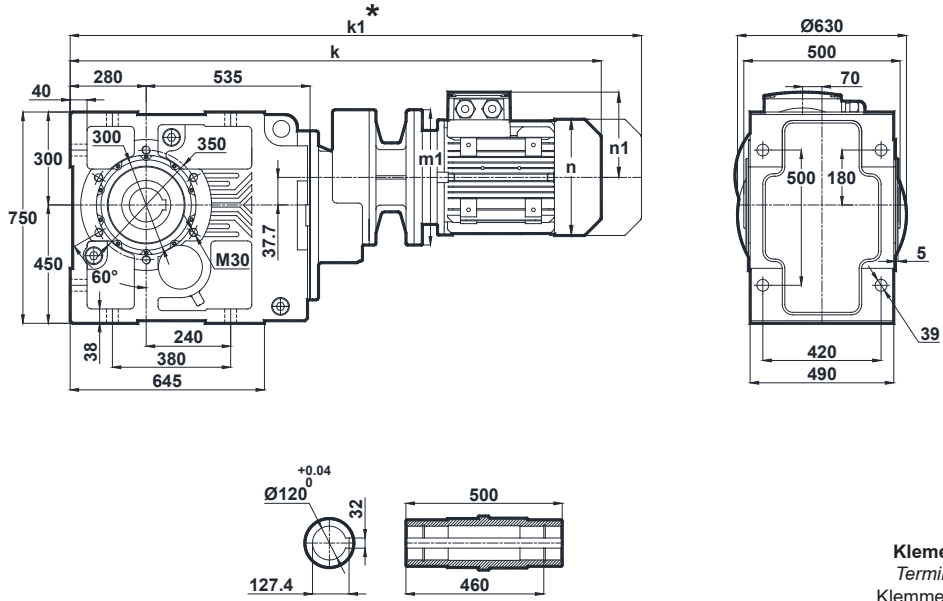

	100L/B5	112M/B5	132S/B5 132S/B14	132M/B5 132M/B14	160M/B5	160L/B5	180M/B5	180L/B5
k	1346	1365.5	1465.5	1465.5	1620.5	1620.5	1712.5	1712.5
k1	1454.5	1470	1595.5	1595.5	1768.5	1768.5	1871	1871
n / n1	193 / 149	215 / 161	257 / 181	257 / 181	316 / 224	316 / 224	348 / 250	348 / 250
m1 (B5)	250	250	300	300	350	350	350	350
m1 (B14)	-	-	200	200	-	-	-	-

Klemens Pozisyonları
Terminal Box Positions
Klemmenkasten Positionen

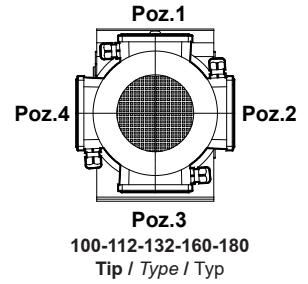

KV974.01

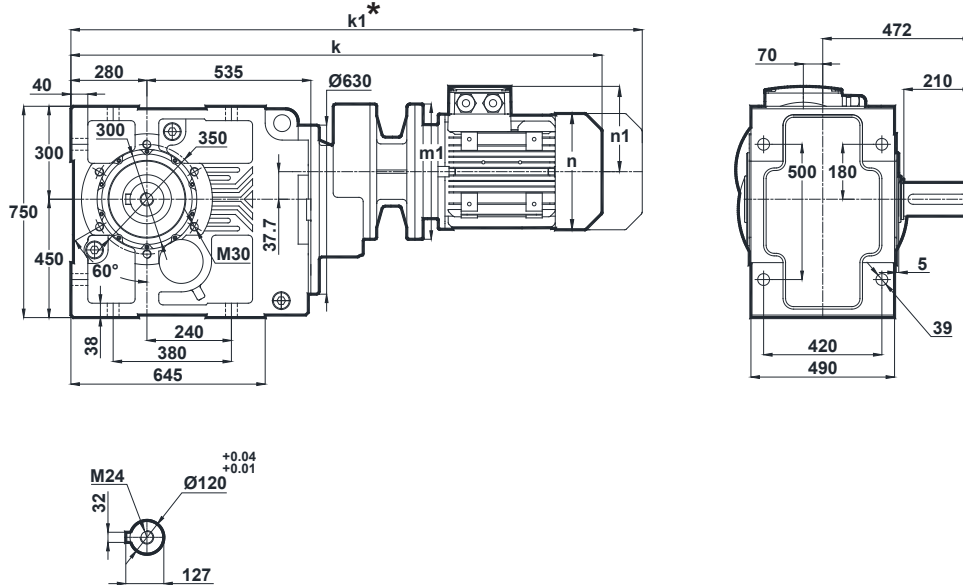

	100L/B5	112M/B5	132S/B5 132S/B14	132M/B5 132M/B14	160M/B5	160L/B5	180M/B5	180L/B5
k	1346	1365.5	1465.5	1465.5	1620.5	1620.5	1712.5	1712.5
k1	1454.5	1470	1595.5	1595.5	1768.5	1768.5	1871	1871
n / n1	193 / 149	215 / 161	257 / 181	257 / 181	316 / 224	316 / 224	348 / 250	348 / 250
m1 (B5)	250	250	300	300	350	350	350	350
m1 (B14)	-	-	200	200	-	-	-	-

* " k1 " Ölçüsü frenli redüktörlere aittir.
Dimension " k1 " is for motors with brake.
Maße " k1 " ist für Bremsenmotoren.

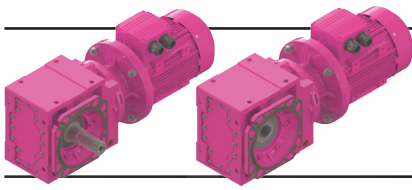

Ölçü Sayfaları

Dimension Pages

Abmessungsseiten

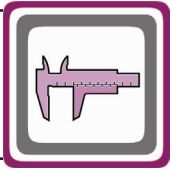

-Mil ucu çektirme deliği DIN 332 sayfa 2 / Tapped center hole to DIN 332, sheet 2 / Zentrierung mit Gewinde DIN 332, Blatt 2

KV974.02

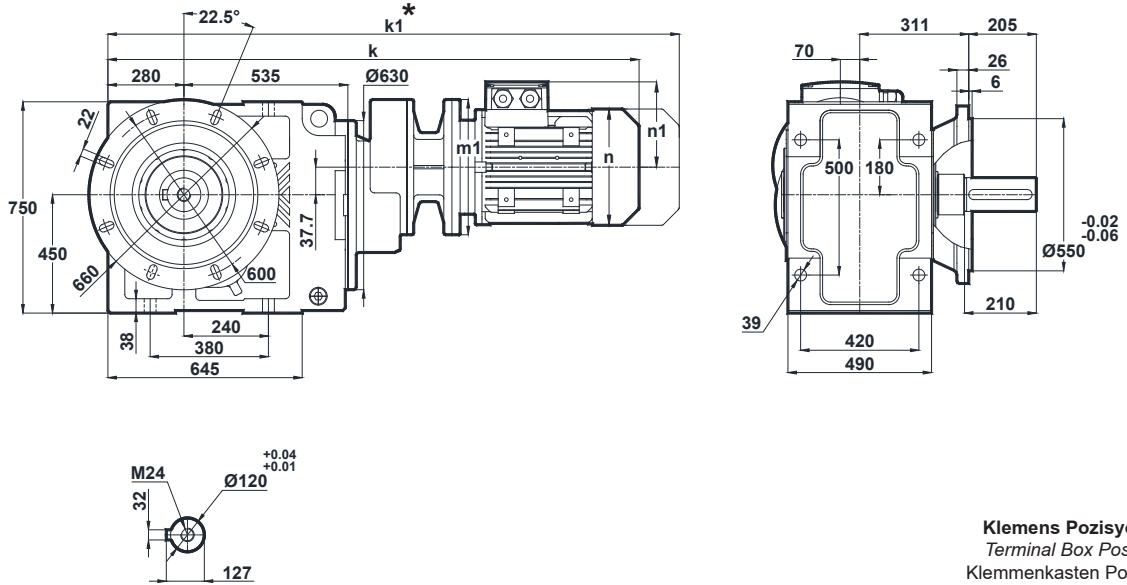

	100L/B5	112M/B5	132S/B5 132S/B14	132M/B5 132M/B14	160M/B5	160L/B5	180M/B5	180L/B5
k	1346	1365.5	1465.5	1465.5	1620.5	1620.5	1712.5	1712.5
k1	1454.5	1470	1595.5	1595.5	1768.5	1768.5	1871	1871
n / n1	193 / 149	215 / 161	257 / 181	257 / 181	316 / 224	316 / 224	348 / 250	348 / 250
m1 (B5)	250	250	300	300	350	350	350	350
m1 (B14)	-	-	200	200	-	-	-	-

Klemens Pozisyonları
Terminal Box Positions
Klemmenkasten Positionen

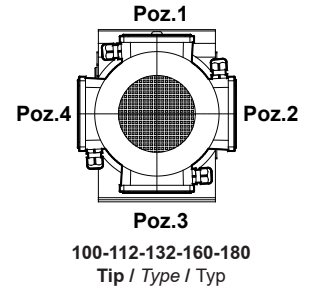

KV974.03

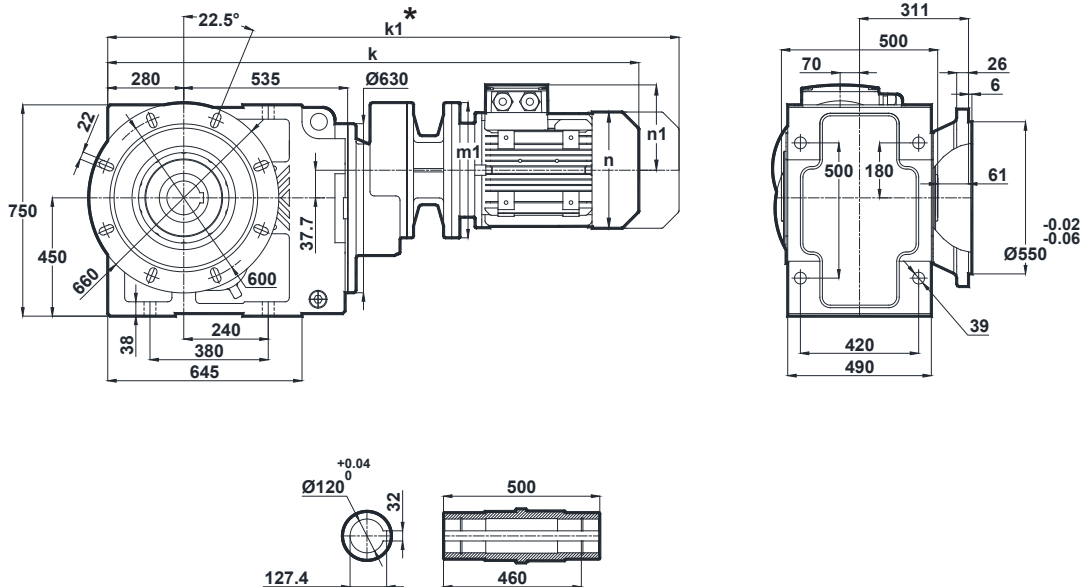

	100L/B5	112M/B5	132S/B5 132S/B14	132M/B5 132M/B14	160M/B5	160L/B5	180M/B5	180L/B5
k	1346	1365.5	1465.5	1465.5	1620.5	1620.5	1712.5	1712.5
k1	1454.5	1470	1595.5	1595.5	1768.5	1768.5	1871	1871
n / n1	193 / 149	215 / 161	257 / 181	257 / 181	316 / 224	316 / 224	348 / 250	348 / 250
m1 (B5)	250	250	300	300	350	350	350	350
m1 (B14)	-	-	200	200	-	-	-	-

* "k1" Ölçüsü frenli redüktörlere aittir.
Dimension "k1" is for motors with brake.
Maße "k1" ist für Bremsenmotoren.

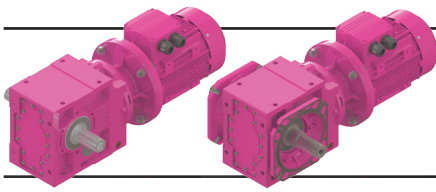

Ölçü Sayfaları

Dimension Pages

Abmessungsseiten

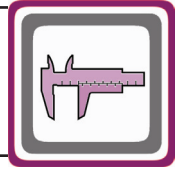

-Mil ucu çekirme deliği DIN 332 sayfa 2 / Tapped center hole to DIN 332, sheet 2 / Zentrierung mit Gewinde DIN 332, Blatt 2

KV974.04

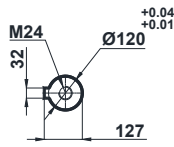
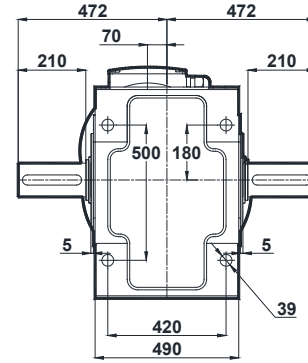
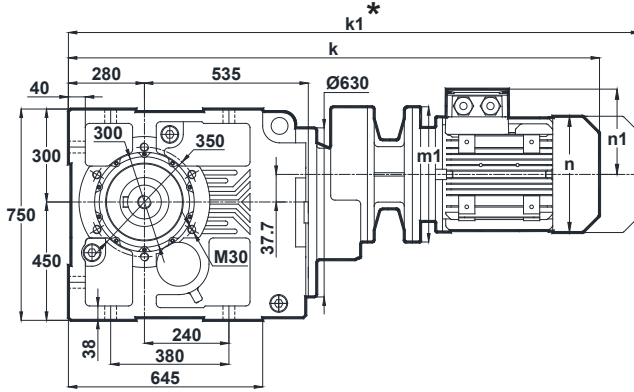

	100L/B5	112M/B5	132S/B5 132S/B14	132M/B5 132M/B14	160M/B5	160L/B5	180M/B5	180L/B5
k	1346	1365.5	1465.5	1465.5	1620.5	1620.5	1712.5	1712.5
k1	1454.5	1470	1595.5	1595.5	1768.5	1768.5	1871	1871
n / n1	193 / 149	215 / 161	257 / 181	257 / 181	316 / 224	316 / 224	348 / 250	348 / 250
m1 (B5)	250	250	300	300	350	350	350	350
m1 (B14)	-	-	200	200	-	-	-	-

Klemens Pozisyonları
Terminal Box Positions
Klemmenkasten Positionen

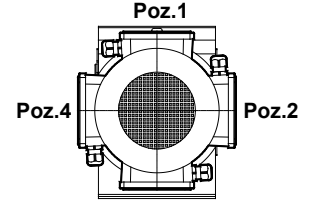

Poz.1
Poz.2
Poz.3
Poz.4
100-112-132-160-180
Tip / Type / Typ

KV974.05

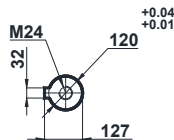
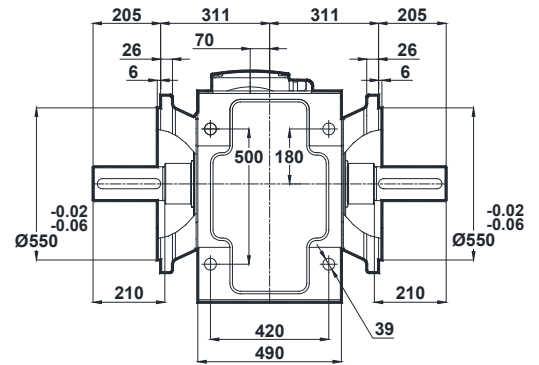
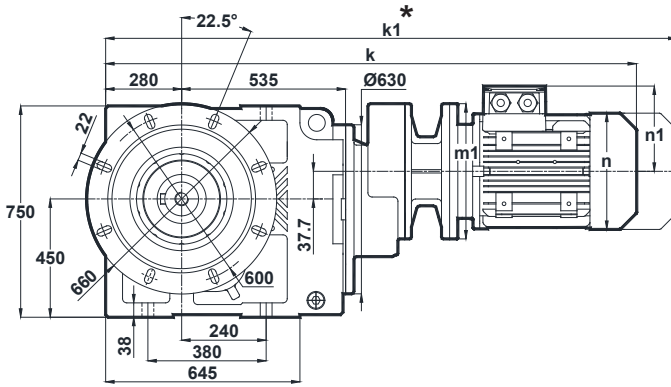

	100L/B5	112M/B5	132S/B5 132S/B14	132M/B5 132M/B14	160M/B5	160L/B5	180M/B5	180L/B5
k	1346	1365.5	1465.5	1465.5	1620.5	1620.5	1712.5	1712.5
k1	1454.5	1470	1595.5	1595.5	1768.5	1768.5	1871	1871
n / n1	193 / 149	215 / 161	257 / 181	257 / 181	316 / 224	316 / 224	348 / 250	348 / 250
m1 (B5)	250	250	300	300	350	350	350	350
m1 (B14)	-	-	200	200	-	-	-	-

* " k1 " Ölçüsü frenli redüktörlere aittir.
Dimension " k1 " is for motors with brake.
Maße " k1 " ist für Bremsenmotoren.

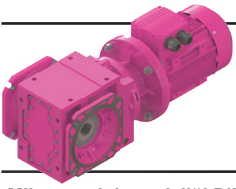

Ölçü Sayfaları Dimension Pages Abmessungsseiten

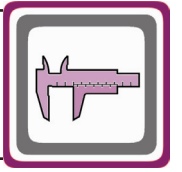

-Mil ucu çekirme deliği DIN 332 sayfa 2 / Tapped center hole to DIN 332, sheet 2 / Zentrierung mit Gewinde DIN 332, Blatt 2

KV974.08

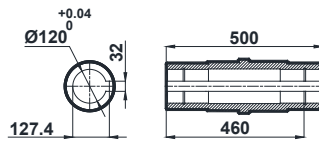
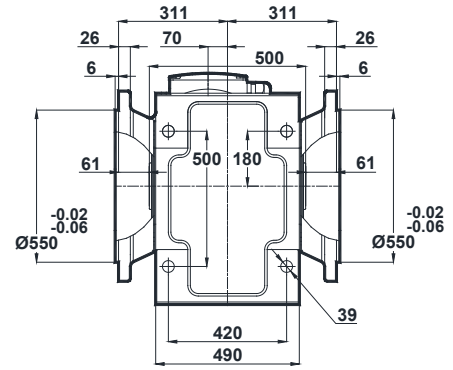
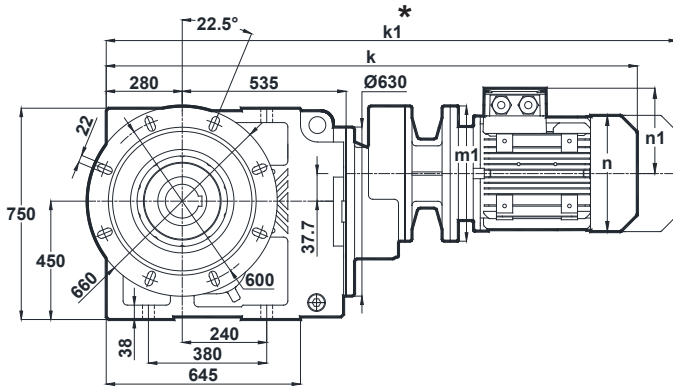

Klemens Pozisyonları
Terminal Box Positions
Klemmenkasten Positionen

	100L/B5	112M/B5	132S/B5 132S/B14	132M/B5 132M/B14	160M/B5	160L/B5	180M/B5	180L/B5
k	1346	1365.5	1465.5	1465.5	1620.5	1620.5	1712.5	1712.5
k1	1454.5	1470	1595.5	1595.5	1768.5	1768.5	1871	1871
n / n1	193 / 149	215 / 161	257 / 181	257 / 181	316 / 224	316 / 224	348 / 250	348 / 250
m1 (B5)	250	250	300	300	350	350	350	350
m1 (B14)	-	-	200	200	-	-	-	-

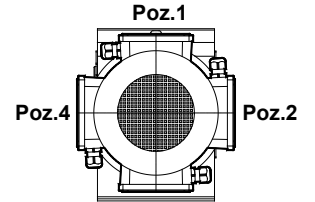

Poz.3
100-112-132-160-180
Tip / Type / Typ

* "k1" Ölçüsü frenli redüktörlere aittir.
Dimension "k1" is for motors with brake.
Maße "k1" ist für Bremsenmotoren.

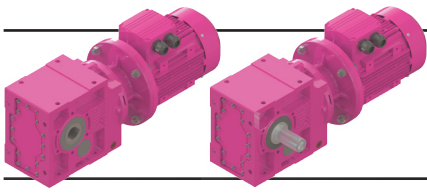

Ölçü Sayfaları

Dimension Pages

Abmessungsseiten

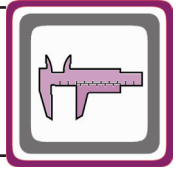

-Mil ucu çektirme deliği DIN 332 sayfa 2 / Tapped center hole to DIN 332, sheet 2 / Zentrierung mit Gewinde DIN 332, Blatt 2

KV975.00
KV976.00

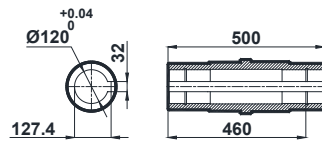
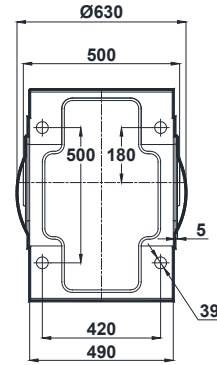
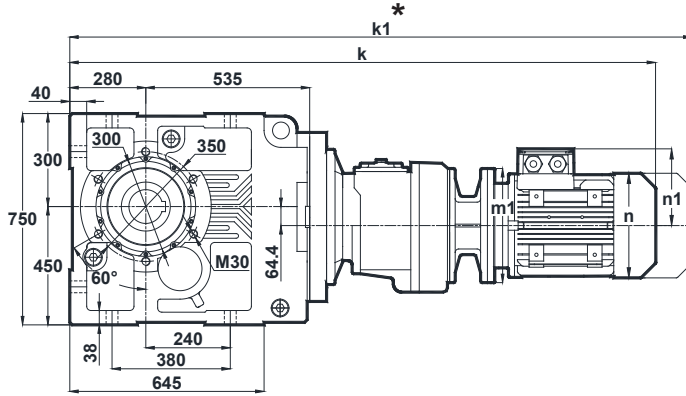

	80/B5 80/B14	90S/B5 90S/B14	90L/B5 90L/B14	100L/B5 100L/B14	112M/B5 112M/B14	132S/B5 132S/B14	132M/B5 132M/B14
k	1405.5	1446.5	1446.5	1500.5	1520	1623.5	1623.5
k1	1498.5	1550	1550	1609	1624.5	1753.5	1753.5
n / n1	155 / 123	176 / 132	176 / 132	193 / 149	215 / 161	257 / 181	257 / 181
m1 (B5)	200	200	200	250	250	300	300
m1 (B14)	-	140	140	160	160	200	200

Klemens Pozisyonları
Terminal Box Positions
Klemmenkasten Positionen

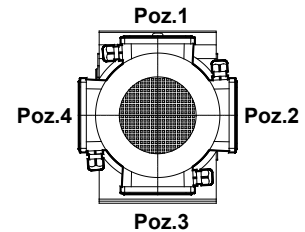

80-90-100-112-132
Tip / Type / Typ

KV975.01
KV976.01

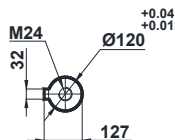
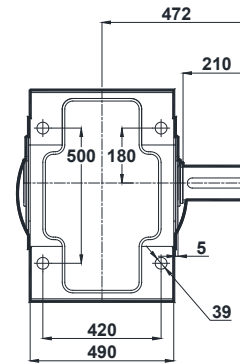
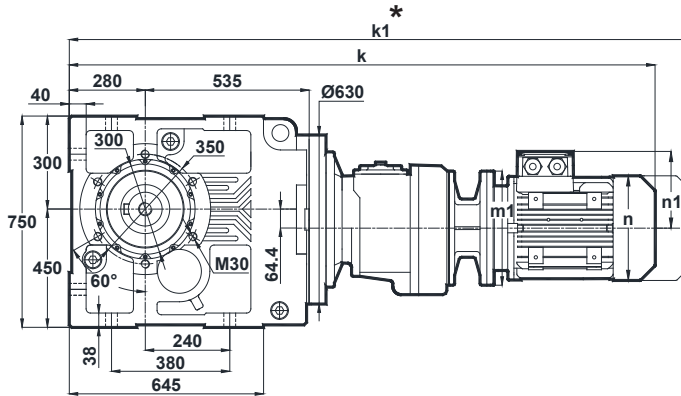

	80/B5 80/B14	90S/B5 90S/B14	90L/B5 90L/B14	100L/B5 100L/B14	112M/B5 112M/B14	132S/B5 132S/B14	132M/B5 132M/B14
k	1405.5	1446.5	1446.5	1500.5	1520	1623.5	1623.5
k1	1498.5	1550	1550	1609	1624.5	1753.5	1753.5
n / n1	155 / 123	176 / 132	176 / 132	193 / 149	215 / 161	257 / 181	257 / 181
m1 (B5)	200	200	200	250	250	300	300
m1 (B14)	-	140	140	160	160	200	200

* " k1 " Ölçüsü frenli redüktörlere aittir.
Dimension " k1 " is for motors with brake.
Maße " k1 " ist für Bremsenmotoren.

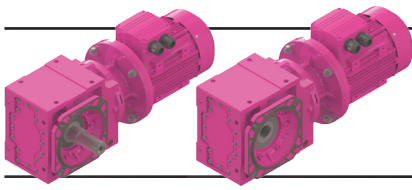

Ölçü Sayfaları

Dimension Pages

Abmessungsseiten



-Mil ucu çektirme deliği DIN 332 sayfa 2 / Tapped center hole to DIN 332, sheet 2 / Zentrierung mit Gewinde DIN 332, Blatt 2

KV975.02
KV976.02

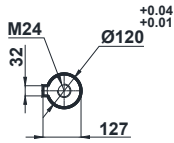
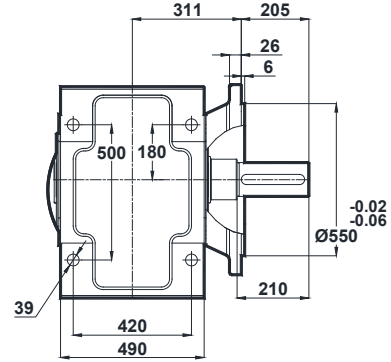
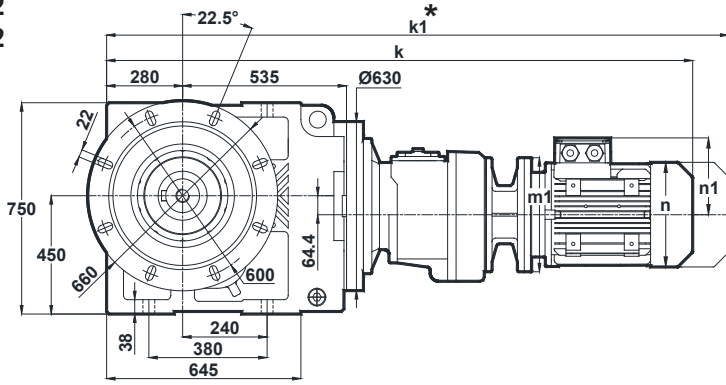

Klemens Pozisyonları
Terminal Box Positions
Klemmenkasten Positionen

	80/B5 80/B14	90S/B5 90S/B14	90L/B5 90L/B14	100L/B5 100L/B14	112M/B5 112M/B14	132S/B5 132S/B14	132M/B5 132M/B14
k	1405.5	1446.5	1446.5	1500.5	1520	1623.5	1623.5
k1	1498.5	1550	1550	1609	1624.5	1753.5	1753.5
n / n1	155 / 123	176 / 132	176 / 132	193 / 149	215 / 161	257 / 181	257 / 181
m1 (B5)	200	200	200	250	250	300	300
m1 (B14)	-	140	140	160	160	200	200

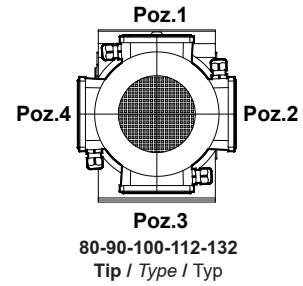

KV975.03
KV976.03

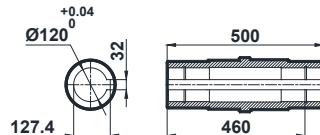
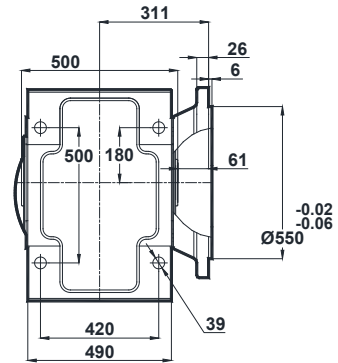
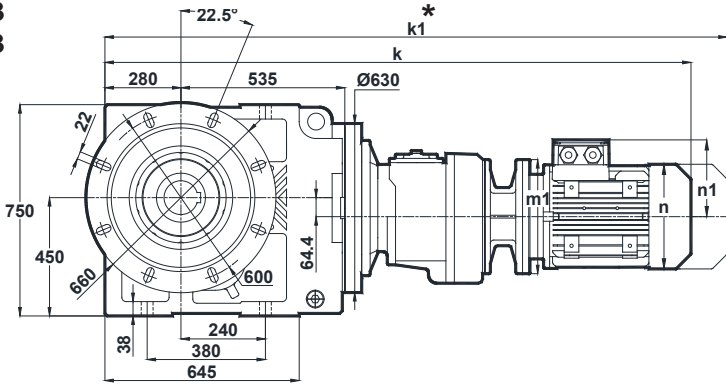

	80/B5 80/B14	90S/B5 90S/B14	90L/B5 90L/B14	100L/B5 100L/B14	112M/B5 112M/B14	132S/B5 132S/B14	132M/B5 132M/B14
k	1405.5	1446.5	1446.5	1500.5	1520	1623.5	1623.5
k1	1498.5	1550	1550	1609	1624.5	1753.5	1753.5
n / n1	155 / 123	176 / 132	176 / 132	193 / 149	215 / 161	257 / 181	257 / 181
m1 (B5)	200	200	200	250	250	300	300
m1 (B14)	-	140	140	160	160	200	200

* "k1" Ölçüsü frenli redüktörlere aittir.
Dimension "k1" is for motors with brake.
Maße "k1" ist für Bremsenmotoren.

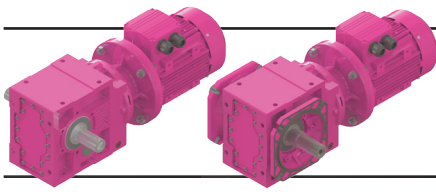

Ölçü Sayfaları

Dimension Pages

Abmessungsseiten

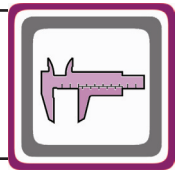

-Mil ucu çektirme deliği DIN 332 sayfa 2 / Tapped center hole to DIN 332, sheet 2 / Zentrierung mit Gewinde DIN 332, Blatt 2

KV975.04
KV976.04

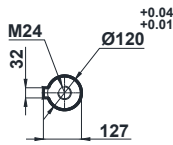
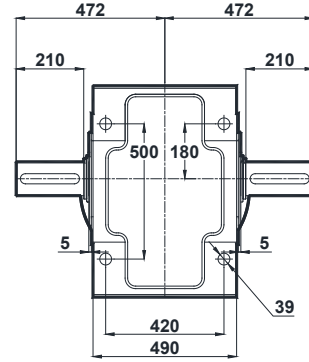
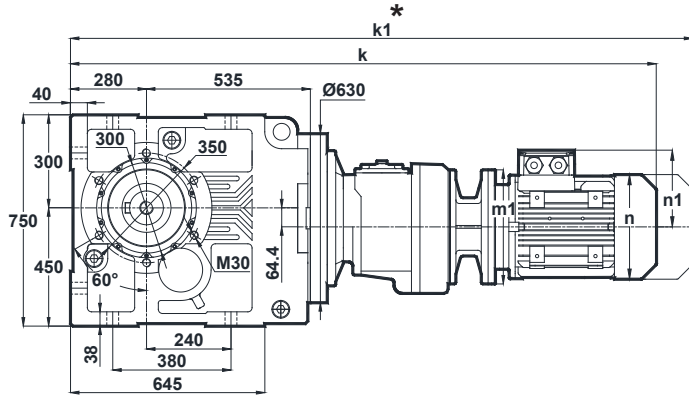

	80/B5 80/B14	90S/B5 90S/B14	90L/B5 90L/B14	100L/B5 100L/B14	112M/B5 112M/B14	132S/B5 132S/B14	132M/B5 132M/B14
k	1405.5	1446.5	1446.5	1500.5	1520	1623.5	1623.5
k1	1498.5	1550	1550	1609	1624.5	1753.5	1753.5
n / n1	155 / 123	176 / 132	176 / 132	193 / 149	215 / 161	257 / 181	257 / 181
m1 (B5)	200	200	200	250	250	300	300
m1 (B14)	-	140	140	160	160	200	200

Klemens Pozisyonları
Terminal Box Positions
Klemmenkasten Positionen

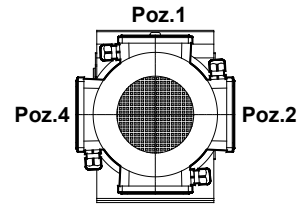

80-90-100-112-132
Tip / Type / Typ

KV975.05
KV976.05

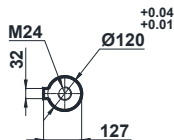
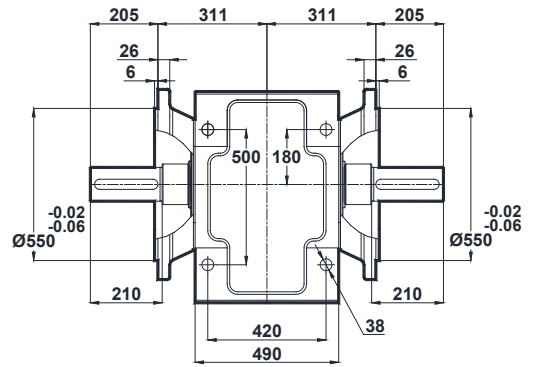
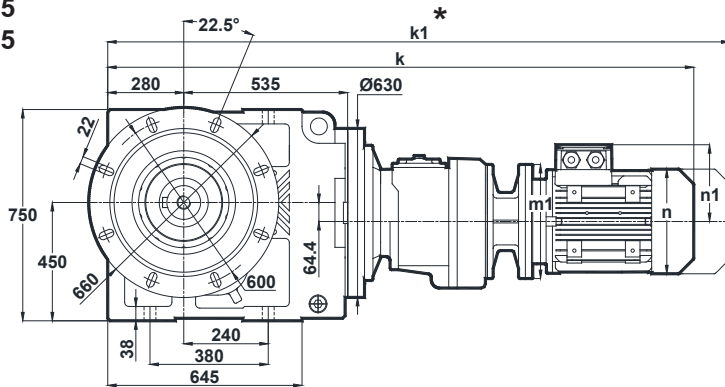

	80/B5 80/B14	90S/B5 90S/B14	90L/B5 90L/B14	100L/B5 100L/B14	112M/B5 112M/B14	132S/B5 132S/B14	132M/B5 132M/B14
k	1405.5	1446.5	1446.5	1500.5	1520	1623.5	1623.5
k1	1498.5	1550	1550	1609	1624.5	1753.5	1753.5
n / n1	155 / 123	176 / 132	176 / 132	193 / 149	215 / 161	257 / 181	257 / 181
m1 (B5)	200	200	200	250	250	300	300
m1 (B14)	-	140	140	160	160	200	200

* " k1 " Ölçüsü frenli redüktörlere aittir.
Dimension " k1 " is for motors with brake.
Maße " k1 " ist für Bremsenmotoren.

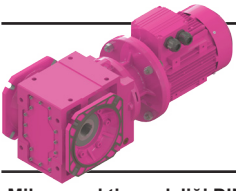

Ölçü Sayfaları Dimension Pages Abmessungsseiten



-Mil ucu çektirme deliği DIN 332 sayfa 2 / Tapped center hole to DIN 332, sheet 2 / Zentrierung mit Gewinde DIN 332, Blatt 2

KV975.08
KV976.08

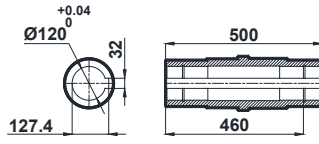
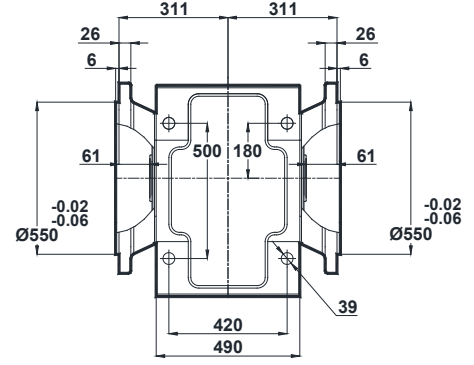
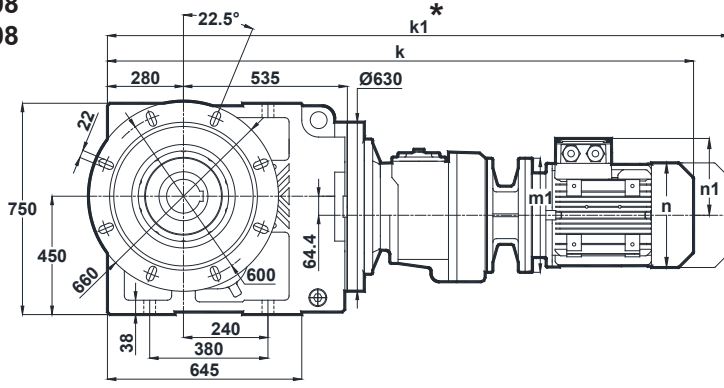

Klemens Pozisyonları
Terminal Box Positions
Klemmenkasten Positionen

	80/B5 80/B14	90S/B5 90S/B14	90L/B5 90L/B14	100L/B5 100L/B14	112M/B5 112M/B14	132S/B5 132S/B14	132M/B5 132M/B14
k	1405.5	1446.5	1446.5	1500.5	1520	1623.5	1623.5
k1	1498.5	1550	1550	1609	1624.5	1753.5	1753.5
n / n1	155 / 123	176 / 132	176 / 132	193 / 149	215 / 161	257 / 181	257 / 181
m1 (B5)	200	200	200	250	250	300	300
m1 (B14)	-	140	140	160	160	200	200

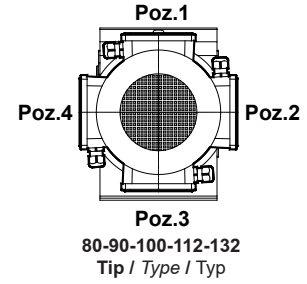

* "k1" Ölçüsü frenli redüktörlere aittir.
Dimension "k1" is for motors with brake.
Maße "k1" ist für Bremsenmotoren.

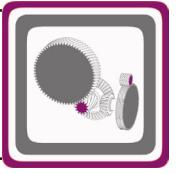
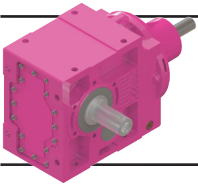

Güç ve Devir Tabloları

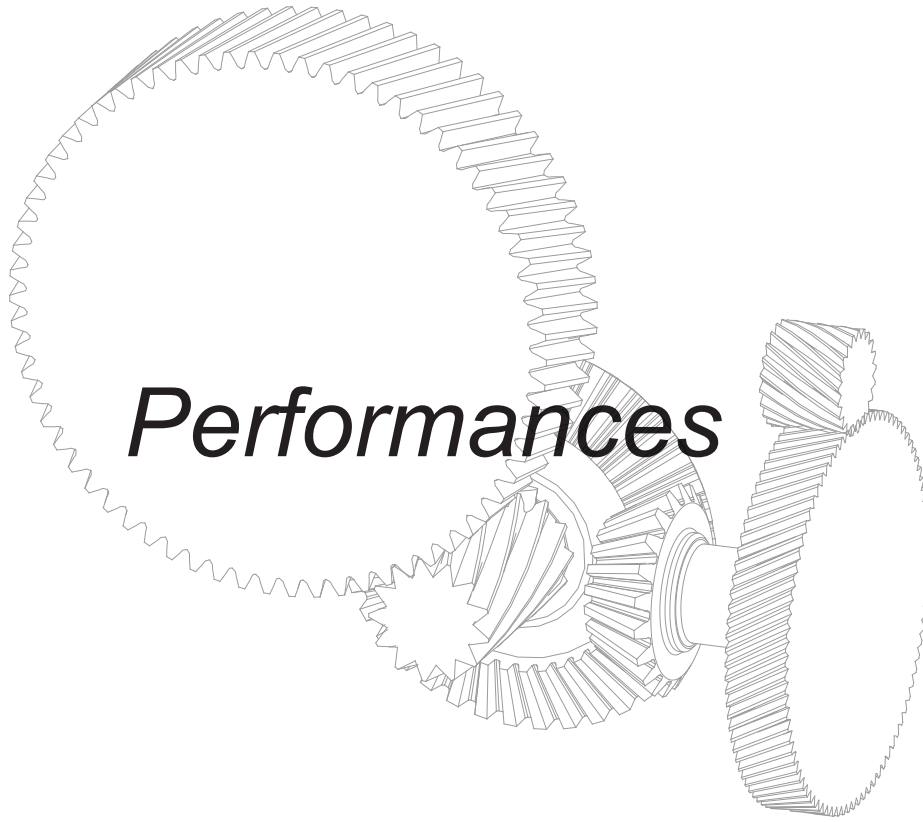

Leistung und Drehzahlübersicht

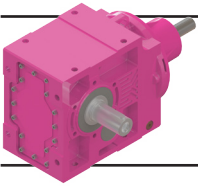

K Serisi Motorsuz Güç Devir Sayfaları

K Series Gear Units Performance Tables

K Serien Getriebe Leistung und Drehzahlübersicht

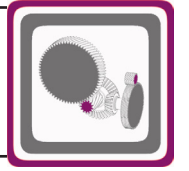

Anma Momenti Nominal Torques Nenn-drehmomente Ma [Nm] (n1=1450rpm)	Çevrim Oranı Ratio Übersetzung i	Çıkış Devri Output Speeds Abtriebs-drehzahlen n2 [r.p.m] (n1=1450rpm)	Tipi Type Typ	Pe= Nominal Güç [kW] (Servis Faktörü fs=1,0 için) Pe= Nominal Power [kW] (For Service Factor fs=1,0) Pe= NennLeistung [kW] (Bei Betriebsfaktor fs=1,0)						Güv. Rad.Yük Çıkış Per.O.Loads (Output) Zul.Querkräfte (Abtrieb) Fqam [N] (n1=1450rpm)	Güv.Rad.Yük Giriş Per.O.Loads (Input) Zul.Querkräfte (Antrieb) Fqem [N] (n1=1450rpm)	Ağırlık Weight Gewicht [kg]	Ölçü Sayfası Dim. Page Maße Seite
				Giriş devri[d/d] / Input speed[rpm] / Antriebsdrehzahl[upm]									
				n1=2900	n1=1450	n1=950	n1=725	n1=475	n1=360				
				65	7,46	194	KT002	2,3	1,4	1,1	0,86	0,56	0,43
65	8,04	180		2,2	1,3	0,98	0,80	0,52	0,40	2748	91		
70	9,40	154		1,9	1,2	0,90	0,69	0,45	0,34	2879	48		
75	11,09	131		1,7	1,1	0,76	0,58	0,38	0,29	3031	-		
75	13,26	109		1,5	0,91	0,64	0,49	0,32	0,24	3265	96		
75	14,73	98		1,3	0,82	0,58	0,44	0,29	0,22	3408	195		
75	16,18	90		1,2	0,75	0,52	0,40	0,26	0,20	3540	211		
80	19,88	73		1,1	0,65	0,43	0,33	0,21	0,16	3794	161		
80	23,79	61	KT003	0,96	0,55	0,36	0,28	0,18	0,14	3153	764	15	458
80	25,64	57		0,89	0,51	0,34	0,26	0,17	0,13	3269	770		
80	29,95	48		0,82	0,44	0,29	0,22	0,15	0,11	3518	781		
80	35,34	41		0,70	0,38	0,25	0,19	0,12	0,09	3799	791		
80	45,41	32		0,58	0,29	0,19	0,15	0,10	0,07	4042	869		
80	48,93	30		0,54	0,27	0,18	0,14	0,09	0,07	4046	872		
80	57,16	25		0,47	0,24	0,15	0,12	0,08	0,06	4046	878		
80	67,44	22		0,40	0,20	0,13	0,10	0,07	0,05	4048	883		
80	80,66	18		0,34	0,17	0,11	0,09	0,06	0,04	4046	887		
80	89,62	16		0,31	0,15	0,10	0,08	0,05	0,04	4046	893		
80	98,44	15		0,28	0,14	0,09	0,07	0,05	0,04	4040	894		
80	120,91	12		0,23	0,12	0,08	0,06	0,04	0,03	4049	896		
90	6,28	231	KT102	3,5	2,3	1,7	1,8	1,2	0,89	2785	-	15	462
90	7,29	199		3,3	2,0	1,5	1,5	1,0	0,77	2971	-		
95	8,72	166		2,9	1,7	1,3	1,3	0,85	0,64	3160	-		
100	10,32	140		2,5	1,5	1,2	1,1	0,71	0,54	3347	-		
100	11,05	131		2,5	1,4	1,1	1,0	0,67	0,51	3446	-		
105	12,51	116		2,2	1,3	1,0	0,90	0,59	0,45	3585	-		
110	14,61	99		2,0	1,2	0,94	0,77	0,51	0,38	3780	-		
110	17,30	84		1,7	1,0	0,79	0,65	0,43	0,33	4062	-		
110	19,13	76		1,5	0,93	0,72	0,59	0,39	0,29	4236	-		
115	21,25	68		1,4	0,87	0,65	0,53	0,35	0,27	4377	-		
120	25,50	57		1,3	0,76	0,58	0,45	0,29	0,22	4672	-		
115	20,03	72	KT103	1,5	0,93	0,70	0,55	0,38	0,29	4176	704	16	462
120	23,22	62		1,3	0,84	0,62	0,50	0,33	0,25	4397	710		
125	27,81	52		1,2	0,74	0,54	0,41	0,27	0,21	4696	722		
130	32,90	44		1,0	0,65	0,46	0,35	0,23	0,18	4992	725		
135	35,22	41		1,0	0,63	0,43	0,33	0,22	0,16	5084	721		
135	38,22	38		0,94	0,58	0,40	0,30	0,20	0,15	5266	812		
140	44,32	33		0,85	0,52	0,34	0,26	0,17	0,13	5553	816		
140	53,07	27		0,74	0,44	0,29	0,22	0,14	0,11	5825	830		
140	62,79	23		0,66	0,37	0,24	0,19	0,12	0,09	5827	838		
140	67,22	22		0,64	0,35	0,23	0,17	0,11	0,09	5823	841		
140	76,13	19		0,59	0,31	0,20	0,15	0,10	0,08	5827	844		
140	88,87	16		0,53	0,26	0,17	0,13	0,09	0,07	5831	849		
140	105,26	14		0,45	0,23	0,15	0,11	0,07	0,06	5826	854		
140	116,34	12		0,41	0,20	0,13	0,10	0,07	0,05	5826	862		
140	129,27	11		0,37	0,18	0,12	0,09	0,06	0,05	5826	864		
205	6,38	227	KT202	8,1	5,1	3,8	3,1	2,3	1,7	2306	-	19	466
215	7,65	190		7,2	4,5	3,3	2,7	1,9	1,5	2473	-		
230	9,25	157		6,3	4,0	2,9	2,4	1,6	1,2	2627	-		
235	10,57	137		5,7	3,5	2,7	2,1	1,4	1,1	2792	128		
245	12,17	119		5,2	3,2	2,4	1,8	1,2	0,92	2937	130		
255	14,32	101		4,5	2,8	2,0	1,6	1,0	0,78	3131	140		
260	15,26	95		4,4	2,7	1,9	1,5	0,96	0,73	3203	121		
270	17,47	83		3,9	2,5	1,7	1,3	0,84	0,64	3367	86		
280	20,23	72		3,5	2,2	1,5	1,1	0,73	0,55	3566	51		
280	23,79	61		3,2	1,9	1,2	0,95	0,62	0,47	3893	189		

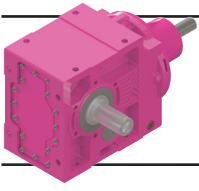

K Serisi Motorsuz Güç Devir Sayfaları

K Series Gear Units Performance Tables

K Serien Getriebe Leistung und Drehzahlübersicht

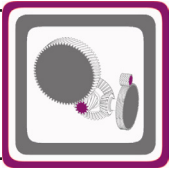

Anma Momenti <i>Nominal Torques</i> Nenn-drehmomente Ma [Nm] (n1=1450rpm)	Çevrim Oranı <i>Ratio</i> Übersetzung i	Çıkış Devri <i>Output Speeds</i> Abtriebs-drehzahlen n2 [r.p.m] (n1=1450rpm)	Tipi <i>Type</i> Typ	Pe= Nominal Güç [kW] (Servis Faktörü fs=1,0 için) <i>Pe= Nominal Power [kW] (For Service Factor fs=1,0)</i> Pe= NennLeistung [kW] (Bei Betriebsfaktor fs=1,0)						Güv. Rad.Yük Çıkış <i>Per.O.Loads (Output)</i> Zul.Querkräfte (Abtrieb) Fqam [N] (n1=1450rpm)	Güv.Rad.Yük Giriş <i>Per.O.Loads (Input)</i> Zul.Querkräfte (Antrieb) Fqem [N] (n1=1450rpm)	Ağırlık <i>Weight</i> Gewicht [kg]	Ölçü Sayfası <i>Dim. Page</i> Maße Seite			
				Giriş devri[d/d] / Input speed[rpm] / Antriebsdrehzahl[upm]												
				n1=2900	n1=1450	n1=950	n1=725	n1=475	n1=360							
265	26,31	55	KT203	2,6	1,6	1,1	0,87	0,57	0,43	3916	1713	20	466			
280	31,55	46		2,3	1,4	0,95	0,72	0,48	0,36	4177	1721					
280	38,16	38		2,0	1,2	0,79	0,60	0,39	0,30	4644	1746					
280	43,67	33		1,8	1,0	0,69	0,52	0,34	0,26	4993	1841					
280	52,37	28		1,6	0,87	0,57	0,44	0,29	0,22	5483	1858					
280	63,33	23		1,4	0,72	0,48	0,36	0,24	0,18	6027	1873					
280	72,37	20		1,3	0,64	0,42	0,32	0,21	0,16	6428	1882					
280	83,32	17		1,1	0,55	0,36	0,28	0,18	0,14	6870	1890					
280	98,01	15		0,94	0,47	0,31	0,24	0,16	0,12	7403	1898					
280	104,49	14		0,88	0,44	0,29	0,22	0,15	0,11	7506	1901					
280	119,62	12		0,77	0,39	0,26	0,20	0,13	0,10	7497	1906					
280	138,53	10		0,67	0,34	0,22	0,17	0,11	0,08	7500	1911					
220	6,94	209		KT273	8,9	5,1	3,4	3,14	2,14	1,91	10742			-	25	470
230	8,28	175			7,8	4,5	2,9	2,73	1,92	1,70	11343			-		
240	9,92	146	6,8		3,9	2,6	2,36	1,65	1,45	12003	35					
250	12,00	121	5,9		3,4	2,2	2,09	1,46	1,27	12743	159					
350	13,34	109	7,3		4,2	2,8	2,54	1,75	1,35	12701	534					
370	15,92	91	6,3		3,8	2,5	2,23	1,50	1,13	12587	631					
390	19,08	76	5,6		3,3	2,2	1,90	1,25	0,95	12465	715					
410	23,08	63	4,9		2,9	1,9	1,57	1,03	0,78	12335	788					
430	25,55	57	4,6		2,7	1,8	1,42	0,93	0,71	12198	1277					
450	30,48	48	4,0		2,4	1,6	1,19	0,78	0,59	12000	1298					
450	36,55	40	3,5		2,0	1,3	0,99	0,65	0,49	12000	1339					
450	44,20	33	3,1		1,6	1,1	0,82	0,54	0,41	12000	1373					
450	50,51	29	2,8		1,4	0,9	0,72	0,47	0,36	12000	1394					
450	58,15	25	2,5		1,2	0,8	0,62	0,41	0,31	12000	1413					
450	68,40	21	2,1		1,1	0,7	0,53	0,35	0,26	12000	1431					
450	72,92	20	2,0		1,0	0,7	0,50	0,33	0,27	12000	1437					
450	83,48	17	1,7		0,87	0,6	0,44	0,29	0,24	12000	1450					
450	96,68	15	1,5		0,75	0,5	0,38	0,27	0,21	12000	1461					
450	113,65	13	1,3		0,64	0,4	0,32	0,23	0,18	12000	1472					
450	112,73	13	KT275	1,4	0,68	0,44	0,34	0,25	0,19	12000	613	28	474			
450	131,68	11		1,2	0,58	0,38	0,29	0,21	0,16	12000	627					
450	200,35	7,2		0,77	0,38	0,25	0,21	0,14	0,11	12000	732					
450	215,91	6,7		0,71	0,36	0,26	0,20	0,13	0,10	12000	736					
450	252,20	5,7		0,61	0,31	0,22	0,17	0,11	0,08	12000	743					
450	300,85	4,8		0,51	0,26	0,19	0,14	0,09	0,07	12000	763					
450	360,73	4,0		0,48	0,24	0,17	0,13	0,09	0,07	12000	781					
450	436,24	3,3		0,39	0,20	0,14	0,11	0,07	0,05	12000	796					
450	498,55	2,9		0,35	0,17	0,13	0,10	0,06	0,05	12000	805					
450	573,99	2,5		0,30	0,15	0,11	0,08	0,05	0,04	12000	814					
450	675,13	2,1		0,26	0,13	0,09	0,07	0,05	0,04	12000	822					
450	719,79	2,0		0,27	0,12	0,09	0,07	0,04	0,03	12000	825					
450	735,42	2,0		KT276	0,27	0,12	0,09	0,07	0,04	0,03	12000			826	30	474
450	881,79	1,6			0,22	0,10	0,07	0,06	0,04	0,03	12000			833		
450	1066,35	1,4	0,18		0,08	0,06	0,05	0,03	0,02	12000	840					
450	1218,69	1,2	0,16		0,07	0,05	0,04	0,03	0,02	12000	843					
450	1403,10	1,0	0,14		0,06	0,05	0,03	0,02	0,02	12000	847					
450	1650,31	0,88	0,12		0,05	0,04	0,03	0,02	0,01	12000	850					
450	1759,48	0,82	0,11		0,05	0,04	0,03	0,02	0,01	12000	851					
335	5,74	253	KT283	15,19	9,43	7,10	5,70	4,38	3,56	12076	-	30	478			
340	6,70	217		13,51	8,20	6,16	5,01	3,79	3,11	12728	-					
350	7,40	196		12,23	7,64	5,72	4,58	3,50	2,87	13118	-					
360	8,63	168		10,85	6,73	5,02	4,07	3,09	2,53	13789	-					
370	10,16	143		9,54	5,88	4,43	3,54	2,71	2,23	14537	-					
550	10,37	140		13,87	8,57	6,12	4,67	3,06	2,32	14048	-					
575	12,10	120		12,41	7,67	5,25	4,00	2,62	1,99	14723	-					
600	14,12	103		11,21	6,86	4,50	3,43	2,25	1,70	15432	-					

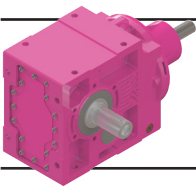

K Serisi Motorsuz Güç Devir Sayfaları

K Series Gear Units Performance Tables

K Serien Getriebe Leistung und Drehzahlübersicht

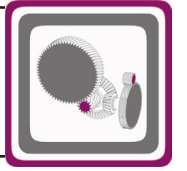

Anma Momenti Nominal Torques Nenn-drehmomente Ma [Nm] (n1=1450rpm)	Çevrim Oranı Ratio Übersetzung i	Çıkış Devri Output Speeds Abtriebs-drehzahlen n2 [r.p.m] (n1=1450rpm)	Tipi Type Typ	Pe= Nominal Güç [kW] (Servis Faktörü fs=1,0 için) Pe= Nominal Power [kW] (For Service Factor fs=1,0) Pe= NennLeistung [kW] (Bei Betriebsfaktor fs=1,0)						Güv. Rad.Yük Çıkış Per.O.Loads (Output) Zul.Querkräfte (Abtrieb) Fqam [N] (n1=1450rpm)	Güv.Rad.Yük Giriş Per.O.Loads (Input) Zul.Querkräfte (Antrieb) Fqem [N] (n1=1450rpm)	Ağırlık Weight Gewicht [kg]	Ölçü Sayfası Dim. Page Maße Seite
				Giriş devri[d/d] / Input speed[rpm] / Antriebsdrehzahl[upm]									
				n1=2900	n1=1450	n1=950	n1=725	n1=475	n1=360				
600	15,60	93	KT283	10,46	6,21	4,07	3,11	2,04	1,54	15750	53	30	478
600	18,21	80		9,32	5,32	3,49	2,66	1,74	1,32	15750	333		
600	21,42	68		8,37	4,53	2,96	2,26	1,48	1,12	15750	583		
600	23,76	61		6,87	4,08	2,67	2,04	1,34	1,01	15750	1595		
600	27,74	52		6,17	3,79	2,29	1,75	1,14	0,87	15750	1641		
600	32,35	45		5,54	3,00	1,96	1,50	0,98	0,74	15750	1686		
600	35,75	41		5,15	2,71	1,78	1,36	0,89	0,67	15750	1708		
600	41,72	35		4,57	2,32	1,52	1,16	0,76	0,58	15750	1739		
600	49,08	30		3,95	1,97	1,29	0,99	0,65	0,49	15750	1766		
600	58,35	25		3,32	1,66	1,09	0,83	0,54	0,41	15750	1790		
600	66,00	22		2,94	1,47	0,96	0,73	0,48	0,36	15750	1805		
600	75,26	19		2,58	1,29	0,84	0,64	0,42	0,32	15750	1818		
600	93,50	16		2,07	1,04	0,68	0,52	0,34	0,26	15750	1838		
600	106,33	14		1,82	0,91	0,60	0,46	0,30	0,25	15750	1847		
600	122,38	12		1,58	0,79	0,52	0,40	0,26	0,22	15750	1856		
600	143,00	10		1,36	0,68	0,44	0,34	0,25	0,19	15750	1864		
600	122,22	12	KT284	1,64	0,82	0,54	0,41	0,27	0,23	15750	1373	40	482
600	135,06	11		1,48	0,74	0,49	0,37	0,27	0,20	15750	1414		
600	157,62	9,2		1,27	0,64	0,42	0,32	0,23	0,18	15750	1469		
600	185,40	7,8		1,08	0,54	0,35	0,27	0,20	0,15	15750	1519		
600	220,43	6,6		0,91	0,46	0,30	0,25	0,17	0,13	15750	1564		
600	249,33	5,8		0,81	0,40	0,26	0,22	0,15	0,11	15750	1591		
600	284,33	5,1		0,71	0,35	0,26	0,20	0,13	0,10	15750	1617		
600	353,22	4,1		0,57	0,28	0,21	0,16	0,10	0,08	15750	1653		
600	300,42	4,8	KT285	0,68	0,34	0,25	0,19	0,12	0,09	15750	1018	45	486
600	359,71	4,0		0,57	0,29	0,21	0,16	0,10	0,08	15750	1029		
600	425,60	3,4		0,54	0,27	0,20	0,15	0,10	0,07	15750	1035		
600	455,64	3,2		0,50	0,25	0,18	0,14	0,09	0,07	15750	1037		
600	516,00	2,8		0,44	0,22	0,16	0,12	0,08	0,06	15750	1040		
600	570,18	2,5		0,40	0,20	0,15	0,11	0,07	0,06	15750	1049		
600	665,46	2,2		0,35	0,17	0,13	0,10	0,06	0,05	15750	1063		
600	782,73	1,9		0,29	0,15	0,11	0,08	0,05	0,04	15750	1075		
600	930,59	1,6		0,27	0,12	0,09	0,07	0,05	0,03	15750	1086		
600	1052,64	1,4		0,24	0,11	0,08	0,06	0,04	0,03	15750	1092		
600	820,35	1,8	KT286	0,28	0,14	0,10	0,08	0,05	0,04	15750	1101	45	486
600	951,33	1,5		0,27	0,12	0,09	0,07	0,04	0,03	15750	1104		
600	1139,09	1,3		0,23	0,10	0,08	0,06	0,04	0,03	15750	1107		
600	1347,72	1,1		0,19	0,09	0,06	0,05	0,03	0,02	15750	1109		
600	1442,85	1,0		0,18	0,08	0,06	0,05	0,03	0,02	15750	1110		
600	1634,00	0,89		0,16	0,07	0,05	0,04	0,03	0,02	15750	1111		
600	1805,57	0,80		0,15	0,07	0,05	0,04	0,02	0,02	15750	1114		
600	2107,29	0,69		0,12	0,06	0,04	0,03	0,02	0,02	15750	1118		
600	2478,65	0,58		0,11	0,05	0,03	0,03	0,02	0,01	15750	1122		
600	2946,88	0,49		0,09	0,04	0,03	0,02	0,01	0,01	15750	1125		
600	3333,36	0,43		0,08	0,04	0,03	0,02	0,01	0,01	15750	1127		
580	5,68	255	KT373	27	17	12	10	7,6	5,8	10852	-	60	490
595	6,63	219		23	15	11	8,8	6,5	5,0	11453	-		
610	7,73	188		21	13	9,7	7,8	5,6	4,3	12082	-		
630	8,54	170		19	12	8,9	7,2	5,1	3,9	12440	-		
655	9,97	145		17	11	7,9	6,4	4,4	3,3	13063	-		
805	10,60	137		20	12	8,2	6,2	4,1	3,1	12341	-		
820	12,38	117		18	11	7,0	5,3	3,5	2,7	11800	-		
820	14,44	100		16	9,2	6,0	4,6	3,0	2,3	11800	-		
820	15,96	91		15	8,3	5,4	4,2	2,7	2,1	11800	-		
820	18,62	78		13	7,1	4,7	3,6	2,3	1,8	11800	-		
820	21,90	66		12	6,0	4,0	3,0	2,0	1,5	11800	-		
820	24,72	59		11	5,4	3,5	2,7	1,8	1,3	11800	1429		
820	28,85	50		9,2	4,6	3,0	2,3	1,5	1,1	11800	1490		
820	33,65	43		7,9	3,9	2,6	2,0	1,3	0,98	11800	1549		

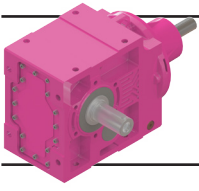

K Serisi Motorsuz Güç Devir Sayfaları

K Series Gear Units Performance Tables

K Serien Getriebe Leistung und Drehzahlübersicht

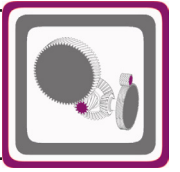

Anma Momenti <i>Nominal Torques</i> Nenn-drehmomente Ma [Nm] (n1=1450rpm)	Çevrim Oranı <i>Ratio</i> Übersetzung i	Çıkış Devri <i>Output Speeds</i> Abtriebs-drehzahlen n2 [r.p.m] (n1=1450rpm)	Tipi <i>Type</i> Typ	Pe= Nominal Güç [kW] (Servis Faktörü fs=1,0 için) <i>Pe= Nominal Power [kW] (For Service Factor fs=1,0)</i> Pe= NennLeistung [kW] (Bei Betriebsfaktor fs=1,0)						Güv. Rad.Yük Çıkış <i>Per.O.Loads (Output)</i>	Güv.Rad.Yük Giriş <i>Per.O.Loads (Input)</i>	Ağırlık <i>Weight</i> Gewicht [kg]	Ölçü Sayfası <i>Dim. Page</i> Maße Seite
				Giriş devri[d/d] / Input speed[rpm] / Antriebsdrehzahl[upm]									
				n1=2900	n1=1450	n1=950	n1=725	n1=475	n1=360	Zul.Querkräfte (Abtrieb)	Zul.Querkräfte (Antrieb)	Fqam [N] (n1=1450rpm)	Fqem [N] (n1=1450rpm)
820	37,19	39	KT373	7,1	3,6	2,3	1,8	1,2	0,88	11800	1579	60	490
820	43,40	33		6,1	3,1	2,0	1,5	1,0	0,76	11800	1619		
820	51,05	28		5,2	2,6	1,7	1,3	0,85	0,64	11800	1654		
820	60,69	24		4,4	2,2	1,4	1,1	0,71	0,54	11800	1686		
820	68,65	21		3,9	1,9	1,3	0,96	0,63	0,48	11800	1705		
820	78,29	19		3,4	1,7	1,1	0,85	0,55	0,42	11800	1723		
820	97,26	15		2,7	1,4	0,89	0,68	0,45	0,34	11800	1749		
820	110,61	13		2,4	1,2	0,78	0,60	0,39	0,30	11800	1761		
820	127,30	11		2,1	1,0	0,68	0,52	0,34	0,26	11800	1773		
820	148,75	9,7		1,8	0,89	0,58	0,45	0,29	0,25	11800	1783		
820	127,14	11	KT374	2,1	1,1	0,70	0,54	0,35	0,27	11800	1411	61	494
820	140,49	10		1,9	0,97	0,64	0,49	0,32	0,27	11800	1450		
820	163,96	8,8		1,7	0,83	0,55	0,42	0,27	0,23	11800	1503		
820	192,86	7,5		1,4	0,71	0,47	0,36	0,26	0,20	11800	1551		
820	229,29	6,3		1,2	0,60	0,39	0,30	0,22	0,16	11800	1594		
820	259,36	5,6		1,1	0,53	0,35	0,26	0,19	0,15	11800	1620		
820	295,76	4,9		0,93	0,46	0,30	0,26	0,17	0,13	11800	1645		
820	367,43	3,9		0,75	0,37	0,27	0,21	0,14	0,10	11800	1679		
820	374,18	3,9	KT375	0,75	0,38	0,27	0,21	0,14	0,10	11800	1047	62	498
820	442,71	3,3		0,64	0,32	0,23	0,18	0,12	0,09	11800	1052		
820	473,96	3,1		0,59	0,30	0,22	0,17	0,11	0,08	11800	1055		
820	536,75	2,7		0,53	0,26	0,19	0,15	0,10	0,07	11800	1057		
820	593,11	2,4		0,53	0,26	0,19	0,15	0,10	0,07	11800	1067		
820	692,22	2,1		0,45	0,23	0,17	0,13	0,08	0,06	11800	1079		
820	814,20	1,8		0,39	0,19	0,14	0,11	0,07	0,05	11800	1091		
820	968,01	1,5		0,32	0,16	0,12	0,09	0,06	0,04	11800	1102		
820	1094,97	1,3		0,29	0,14	0,10	0,08	0,05	0,04	11800	1108		
820	1184,90	1,2	KT376	0,27	0,14	0,10	0,08	0,05	0,04	11800	1122	64	498
820	1401,91	1,0		0,25	0,11	0,08	0,06	0,04	0,03	11800	1124		
820	1500,87	0,97		0,24	0,11	0,08	0,06	0,04	0,03	11800	1125		
820	1699,70	0,85		0,21	0,09	0,07	0,05	0,03	0,03	11800	1125		
820	1878,17	0,77		0,19	0,09	0,06	0,05	0,03	0,02	11800	1128		
820	2192,03	0,66		0,16	0,07	0,05	0,04	0,03	0,02	11800	1132		
820	2578,32	0,56		0,14	0,06	0,05	0,03	0,02	0,02	11800	1136		
820	3065,37	0,47		0,12	0,05	0,04	0,03	0,02	0,01	11800	1139		
820	3467,39	0,42		0,10	0,05	0,03	0,03	0,02	0,01	11800	1141		
830	6,21	233	KT473	35	22	16	12	9,9	8,1	12268	-	96	502
865	7,48	194		30	19	14	11	8,6	7,0	13041	-		
905	9,06	160		26	16	12	9,2	7,4	6,1	13870	-		
935	10,34	140		24	15	11	8,4	6,7	5,5	14467	-		
970	11,87	122		21	13	9,9	7,5	6,1	5,0	15099	-		
1005	13,71	106		19	12	8,9	6,8	5,5	4,5	15811	-		
1370	15,33	95		23	14	11	8,2	5,4	4,1	16173	-		
1425	17,49	83		21	13	9,4	7,2	4,7	3,6	16829	-		
1485	20,07	72		19	12	8,2	6,2	4,1	3,1	17538	-		
1550	23,19	63		18	11	7,1	5,4	3,5	2,7	17000	-		
1550	23,76	61		17	11	6,9	5,3	3,5	2,6	17000	-		
1550	25,15	58		17	10	6,5	5,0	3,3	2,5	17000	-		
1550	30,11	48		15	8,3	5,4	4,2	2,7	2,1	17000	-		
1550	39,11	37		12	6,4	4,2	3,2	2,1	1,6	17000	1424		
1550	44,64	32		11	5,6	3,7	2,8	1,8	1,4	17000	1563		
1550	51,22	28		9,6	4,9	3,2	2,4	1,6	1,2	17000	1612		
1550	59,19	24		8,5	4,2	2,8	2,1	1,4	1,1	17000	1657		
1550	60,63	24		8,3	4,1	2,7	2,1	1,4	1,0	17000	1668		
1550	64,17	23		7,8	3,9	2,6	2,0	1,3	0,97	17000	1683		
1550	76,83	19		6,5	3,3	2,1	1,6	1,1	0,81	17000	1726		
1550	87,49	17		5,7	2,9	1,9	1,4	0,94	0,71	17000	1753		

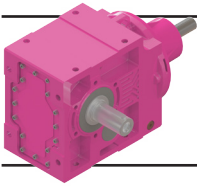

K Serisi Motorsuz Güç Devir Sayfaları

K Series Gear Units Performance Tables

K Serien Getriebe Leistung und Drehzahlübersicht

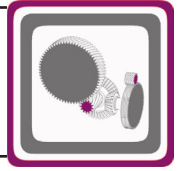

Anma Momenti <i>Nominal Torques</i> Nenn-drehmomente Ma [Nm] (n1=1450rpm)	Çevrim Oranı <i>Ratio</i> Übersetzung i	Çıkış Devri <i>Output Speeds</i> Abtriebs-drehzahlen n2 [r.p.m] (n1=1450rpm)	Tipi <i>Type</i> Typ	Pe= Nominal Güç [kW] (Servis Faktörü fs=1,0 için) <i>Pe= Nominal Power [kW] (For Service Factor fs=1,0)</i> Pe= NennLeistung [kW] (Bei Betriebsfaktor fs=1,0)						Güv. Rad.Yük Çıkış <i>Per.O.Loads (Output)</i> Zul.Querkräfte (Abtrieb) Fçqm [N] (n1=1450rpm)	Güv.Rad.Yük Giriş <i>Per.O.Loads (Input)</i> Zul.Querkräfte (Antrieb) Fçqm [N] (n1=1450rpm)	Ağırlık <i>Weight</i> Gewicht [kg]	Ölçü Sayfası Maße Seite
				Giriş devri[d/d] / Input speed[rpm] / Antriebsdrehzahl[upm]									
				n1=2900	n1=1450	n1=950	n1=725	n1=475	n1=360				
				1550	97,79	15	KT473	5,1	2,6	1,7	1,3	0,84	0,64
1550	110,65	13		4,5	2,3	1,5	1,1	0,74	0,56	17000	1796		
1550	135,98	11		3,7	1,8	1,2	0,92	0,60	0,46	17000	1823		
1550	153,47	9,4		3,3	1,6	1,1	0,82	0,53	0,41	17000	1835		
1550	160,79	9,0	KT474	3,2	1,6	1,0	0,80	0,52	0,40	17000	1870	98	506
1550	181,88	8,0		2,8	1,4	0,93	0,71	0,46	0,35	17000	1883		
1550	207,41	7,0		2,5	1,2	0,82	0,62	0,41	0,31	17000	1896		
1550	257,67	5,6		2,0	1,0	0,66	0,50	0,33	0,28	17000	1914		
1550	293,03	4,9		1,8	0,88	0,58	0,44	0,29	0,24	17000	1922		
1550	310,16	4,7		1,7	0,84	0,55	0,42	0,27	0,23	17000	1940		
1550	371,35	3,9		1,4	0,70	0,46	0,35	0,25	0,19	17000	1988		
1550	422,88	3,4		1,2	0,61	0,40	0,31	0,22	0,17	17000	2018		
1550	472,63	3,1		1,1	0,55	0,36	0,27	0,20	0,15	17000	2040		
1550	509,34	2,8	KT475	1,0	0,52	0,34	0,26	0,19	0,14	17000	1721	101	510
1550	610,72	2,4		0,87	0,43	0,28	0,24	0,16	0,12	17000	1729		
1550	655,16	2,2		0,81	0,40	0,27	0,22	0,15	0,11	17000	1731		
1550	738,55	2,0		0,72	0,36	0,26	0,20	0,13	0,10	17000	1735		
1550	844,06	1,7		0,63	0,32	0,23	0,18	0,11	0,09	17000	1740		
1550	901,03	1,6		0,59	0,30	0,22	0,16	0,11	0,08	17000	1741		
1550	971,77	1,5		0,55	0,27	0,20	0,15	0,10	0,08	17000	1743		
1550	1142,99	1,3		0,52	0,26	0,19	0,14	0,09	0,07	17000	1747		
1550	1218,61	1,2		0,49	0,24	0,18	0,14	0,09	0,07	17000	1748		
1550	1395,04	1,0		0,43	0,21	0,16	0,12	0,08	0,06	17000	1751		
1550	1476,60	0,98		0,40	0,20	0,15	0,11	0,07	0,06	17000	1755		
1550	1767,90	0,82		0,34	0,17	0,12	0,09	0,06	0,05	17000	1766		
1550	2183,54	0,66	KT476	0,28	0,14	0,10	0,08	0,05	0,04	17000	1792	104	510
1550	2495,47	0,58		0,27	0,12	0,09	0,07	0,04	0,03	17000	1794		
1550	2663,91	0,54		0,25	0,11	0,08	0,06	0,04	0,03	17000	1794		
1550	2873,07	0,50		0,23	0,11	0,08	0,06	0,04	0,03	17000	1795		
1550	3379,28	0,43		0,20	0,09	0,07	0,05	0,03	0,02	17000	1796		
1550	3602,83	0,40		0,19	0,08	0,06	0,05	0,03	0,02	17000	1797		
1550	4124,46	0,35		0,16	0,07	0,05	0,04	0,03	0,02	17000	1797		
1550	4365,60	0,33		0,15	0,07	0,05	0,04	0,03	0,02	17000	1799		
1550	5226,85	0,28		0,13	0,06	0,04	0,03	0,02	0,02	17000	1803		
1220	6,91	210	KT573	-	29	21	17	13	10,7	25040	-	138	514
1300	8,07	180		-	26	22	16	12	9,5	26129	-		
1380	9,48	153		38	24	18	14	11	8,9	27341	-		
1470	11,22	129		35	21	16	13	10	8,0	28667	-		
1700	11,58	125		-	24	18	14	11	9,0	28654	-		
1820	13,53	107		-	22	16	13	10	8,0	29850	-		
1930	15,88	91		32	20	15	12	9,0	6,8	31234	-		
2050	18,80	77		29	18	13	11	7,6	5,8	32541	-		
2100	20,24	72		28	17	13	10	7,1	5,4	31991	-		
2200	22,77	64		26	16	12	9,5	6,3	4,8	30822	-		
2300	25,78	56		24	14	11	8,5	5,5	4,2	29547	-		
2300	30,25	48		-	12	9,2	7,2	4,7	3,6	29547	2775		
2430	35,34	41		-	11	8,1	6,2	4,0	3,1	27711	2799		
2500	38,16	38		17	11	7,5	5,7	3,7	2,8	26625	2845		
2620	44,73	32		15	9,5	6,4	4,9	3,2	2,4	24571	2869		
2700	52,88	27		14	8,2	5,4	4,1	2,7	2,0	22500	2909		
2700	59,49	24		13	7,3	4,8	3,7	2,4	1,8	22500	2956		
2700	67,37	22		12	6,5	4,2	3,2	2,1	1,6	22500	3000		
2700	82,14	18		10	5,3	3,5	2,7	1,7	1,3	22500	3058		
2700	97,19	15		9,0	4,5	2,9	2,2	1,5	1,1	22500	3099		
2700	109,86	13		7,9	4,0	2,6	2,0	1,3	0,99	22500	3125		
2700	125,51	12		6,9	3,5	2,3	1,7	1,1	0,86	22500	3149		

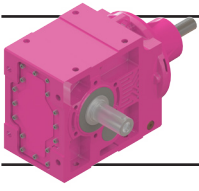

K Serisi Motorsuz Güç Devir Sayfaları

K Series Gear Units Performance Tables

K Serien Getriebe Leistung und Drehzahlübersicht

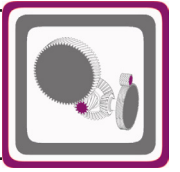

Anma Momenti Nominal Torques Nenn-drehmomente Ma [Nm] (n1=1450rpm)	Çevrim Oranı	Çıkış Devri	Tipi Type Typ	Pe= Nominal Güç [kW] (Servis Faktörü fs=1,0 için)						Güv. Rad.Yük Çıkış	Güv.Rad.Yük Giriş	Ağırlık Weight Gewicht [kg]	Ölçü Sayfası Dim. Page Maße Seite
	Ratio	Output Speeds		Pe= Nominal Power [kW] (For Service Factor fs=1,0)						Per.O.Loads (Output)	Per.O.Loads (Input)		
	Übersetzung	Abtriebs-drehzahlen		Pe= NennLeistung [kW] (Bei Betriebsfaktor fs=1,0)						Zul.Querkräfte (Abtrieb)	Zul.Querkräfte (Antrieb)		
	i	n2 [r.p.m] (n1=1450rpm)		Giriş devri[d/d] / Input speed[rpm] / Antriebsdrehzahl[upm]						Fqam [N] (n1=1450rpm)	Fqem [N] (n1=1450rpm)		
				n1=2900	n1=1450	n1=950	n1=725	n1=475	n1=360				
2700	117,96	12	KT574	7,6	3,8	2,5	1,9	1,2	0,94	22500	1466	140	518
2700	140,24	10		6,4	3,2	2,1	1,6	1,0	0,79	22500	1510		
2700	158,64	9,1		5,7	2,8	1,9	1,4	0,93	0,70	22500	1536		
2700	180,90	8,0		5,0	2,5	1,6	1,2	0,81	0,62	22500	1561		
2700	211,51	6,9		4,3	2,1	1,4	1,1	0,70	0,53	22500	1587		
2700	237,97	6,1		3,8	1,9	1,2	0,95	0,62	0,47	22500	1659		
2700	246,42	5,9		3,6	1,8	1,2	0,91	0,60	0,45	22500	1785		
2700	281,00	5,2		3,2	1,6	1,0	0,80	0,52	0,40	22500	1801		
2700	328,56	4,4		2,7	1,4	0,90	0,69	0,45	0,34	22500	1817		
2700	397,01	3,7		2,3	1,1	0,75	0,57	0,37	0,28	22500	1834		
2700	469,74	3,1		1,9	0,96	0,63	0,48	0,32	0,27	22500	1896		
2700	507,09	2,9		KT575	1,8	0,91	0,60	0,46	0,30	0,25	22500		
2700	570,53	2,5	1,6		0,81	0,53	0,41	0,27	0,22	22500	1520		
2700	787,70	1,8	1,2		0,59	0,39	0,29	0,21	0,16	22500	1603		
2700	932,00	1,6	1,0		0,50	0,33	0,28	0,18	0,14	22500	1637		
2700	1216,74	1,2	0,77		0,38	0,25	0,21	0,14	0,11	22500	1680		
2700	1368,95	1,1	0,68		0,34	0,25	0,19	0,12	0,09	22500	1696		
2700	1890,04	0,77	0,55		0,27	0,20	0,15	0,10	0,08	22500	1731		
2700	2236,28	0,65	0,46		0,23	0,17	0,13	0,08	0,06	22500	1745		
2700	2328,84	0,62	KT576	0,45	0,23	0,17	0,13	0,08	0,06	22500	1748	145	522
2700	2755,47	0,53		0,38	0,19	0,14	0,11	0,07	0,05	22500	1759		
2700	3597,31	0,40		0,29	0,15	0,11	0,08	0,05	0,04	22500	1774		
2700	4047,32	0,36		0,26	0,13	0,10	0,07	0,05	0,04	22500	1779		
2700	5587,93	0,26		0,21	0,09	0,07	0,05	0,03	0,03	22500	1791		
2700	6611,61	0,22		0,18	0,08	0,06	0,04	0,03	0,02	22500	1795		
2500	8,31	175	KT673	-	49	37	30	23	18	38163	-	235	526
2600	9,45	153		-	44	33	27	20	16	39661	-		
2700	10,81	134		-	40	30	24	19	14	41324	-		
2800	12,46	116		58	36	27	22	16	12	43197	-		
2900	14,49	100		52	32	24	20	14	11	45335	-		
4300	16,54	88		-	42	28	21	14	10	29600	-		
4300	18,74	77		-	37	24	19	12	9,2	29600	-		
4300	21,32	68		-	33	21	16	11	8,1	29600	-		
4300	24,38	59		-	28	19	14	9,3	7,1	29600	-		
4300	28,10	52		49	25	16	12	8,1	6,1	29600	-		
4300	32,68	44		43	21	14	11	7,0	5,3	29600	-		
4300	39,26	37		-	18	12	8,8	5,8	4,4	29600	3132		
4300	44,65	32		-	16	10	7,8	5,1	3,9	29600	3223		
4300	51,08	28		-	14	8,9	6,8	4,5	3,4	29600	3306		
4300	58,86	25		24	12	7,7	5,9	3,9	2,9	29600	3381		
4300	68,47	21		20	10	6,6	5,1	3,3	2,5	29600	3451		
4300	80,38	18		17	8,6	5,7	4,3	2,8	2,1	29600	3541		
4300	90,21	16		15	7,7	5,0	3,8	2,5	1,9	29600	3579		
4300	100,90	14		14	6,9	4,5	3,4	2,3	1,7	29600	3600		
4300	128,24	11		11	5,4	3,5	2,7	1,8	1,3	29600	3675		
4300	123,38	12	KT674	11	5,7	3,8	2,9	1,9	1,4	29600	687	238	530
4300	140,49	10		10	5,1	3,3	2,5	1,7	1,3	29600	808		
4300	157,02	9,2		9,1	4,5	3,0	2,3	1,5	1,1	29600	920		
4300	178,62	8,1		8,0	4,0	2,6	2,0	1,3	0,99	29600	1342		
4300	204,32	7,1		7,0	3,5	2,3	1,7	1,1	0,87	29600	1616		
4300	235,44	6,2		6,1	3,0	2,0	1,5	0,99	0,75	29600	1702		
4300	273,88	5,3		5,2	2,6	1,7	1,3	0,85	0,65	29600	1781		
4300	321,51	4,5		4,4	2,2	1,5	1,1	0,73	0,55	29600	1853		
4300	363,81	4,0		3,9	2,0	1,3	0,98	0,64	0,49	29600	1865		

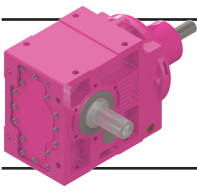

K Serisi Motorsuz Güç Devir Sayfaları

K Series Gear Units Performance Tables

K Serien Getriebe Leistung und Drehzahlübersicht

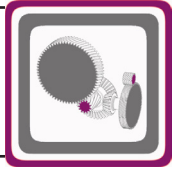

Anma Momenti Nominal Torques Nenn-drehmomente Ma [Nm] (n1=1450rpm)	Çevrim Oranı Ratio Übersetzung i	Çıkış Devri Output Speeds Abtriebs-drehzahlen n2 [r.p.m] (n1=1450rpm)	Tipi Type Typ	Pe= Nominal Güç [kW] (Servis Faktörü fs=1,0 için) Pe= Nominal Power [kW] (For Service Factor fs=1,0) Pe= NennLeistung [kW] (Bei Betriebsfaktor fs=1,0)						Güv. Rad.Yük Çıkış	Güv.Rad.Yük Giriş	Ağırlık Weight Gewicht [kg]	Ölçü Sayfası Dim. Page Maße Seite
				Giriş devri[d/d] / Input speed[rpm] / Antriebsdrehzahl[upm]						Zul.Querkräfte (Abtrieb)	Zul.Querkräfte (Antrieb)		
				n1=2900	n1=1450	n1=950	n1=725	n1=475	n1=360	Fqam [N] (n1=1450rpm)	Fqem [N] (n1=1450rpm)		
4300	423,90	3,4	KT675	3,4	1,7	1,1	0,86	0,56	0,43	29600	1852	243	534
4300	489,82	3,0		3,0	1,5	0,98	0,75	0,49	0,37	29600	1863		
4300	531,08	2,7		2,8	1,4	0,90	0,69	0,45	0,34	29600	1869		
4300	635,86	2,3		2,3	1,2	0,76	0,58	0,38	0,29	29600	1880		
4300	724,08	2,0		2,0	1,0	0,66	0,51	0,33	0,25	29600	1886		
4300	809,27	1,8		1,8	0,91	0,59	0,45	0,30	0,25	29600	1892		
4300	915,75	1,6		1,6	0,80	0,53	0,40	0,26	0,22	29600	1897		
4300	1041,68	1,4		1,4	0,71	0,46	0,35	0,26	0,20	29600	1916		
4300	1191,60	1,2		1,2	0,62	0,41	0,31	0,23	0,17	29600	1933		
4300	1373,07	1,1		1,1	0,54	0,35	0,27	0,20	0,15	29600	1949		
4300	1597,25	0,91		0,92	0,46	0,30	0,26	0,17	0,13	29600	1963		
4300	1875,03	0,77		0,79	0,39	0,26	0,22	0,14	0,11	29600	1977		
4300	1884,33	0,77	KT676	0,80	0,40	0,26	0,22	0,15	0,11	29600	2009	250	534
4300	2082,19	0,70		0,72	0,36	0,26	0,20	0,13	0,10	29600	2011		
4300	2430,14	0,60		0,62	0,31	0,23	0,17	0,11	0,09	29600	2014		
4300	2858,39	0,51		0,53	0,26	0,19	0,15	0,10	0,07	29600	2016		
4300	3398,35	0,43		0,50	0,25	0,18	0,14	0,09	0,07	29600	2018		
4300	3844,04	0,38		0,44	0,22	0,16	0,12	0,08	0,06	29600	2020		
4300	4383,55	0,33		0,39	0,19	0,14	0,11	0,07	0,05	29600	2021		
4300	5445,72	0,27		0,31	0,16	0,11	0,09	0,06	0,04	29600	2023		
4300	6193,17	0,23		0,27	0,14	0,10	0,08	0,05	0,04	29600	2024		
4300	7044,81	0,21		0,27	0,12	0,09	0,07	0,04	0,03	29600	2027		
4300	8058,67	0,18		0,23	0,11	0,08	0,06	0,04	0,03	29600	2030		
4300	9285,97	0,16		0,20	0,09	0,07	0,05	0,03	0,03	29600	2033		
4300	10802,05	0,13		0,17	0,08	0,06	0,04	0,03	0,02	29600	2036		
4300	12680,66	0,11		0,15	0,07	0,05	0,04	0,02	0,02	29600	2038		
3900	7,41	196	KT773	-	80	64	51	39	31	33549	-	360	538
4050	8,52	170		-	72	57	46	35	27	35041	-		
4200	9,83	147		-	65	52	41	31	24	36696	-		
4250	10,20	142		-	63	50	40	30	23	37083	-		
4400	11,44	127		-	58	46	37	27	20	38376	-		
4500	12,89	112		-	53	42	34	24	18	40022	-		
7250	15,25	95		-	72	56	42	28	21	36482	-		
7550	17,52	83		-	65	48	37	24	18	38064	-		
7900	20,23	72		-	59	42	32	21	16	39680	-		
8000	20,97	69		-	58	40	31	20	15	40071	-		
8000	23,52	62		-	52	36	27	18	14	42417	-		
8000	26,52	55		-	46	32	24	16	12	44953	-		
8000	29,40	49		-	41	29	22	14	11	47214	374		
8000	33,78	43		-	36	25	19	13	9,5	50370	1262		
8000	39,00	37		-	31	22	17	11	8,2	53774	2055		
8000	40,44	36		-	30	21	16	10	7,9	54659	2095		
8000	45,36	32		-	27	19	14	9,3	7,1	55500	2636		
8000	51,13	28		-	24	17	13	8,3	6,3	55500	3136		
8000	58,00	25		-	21	15	11	7,3	5,5	55500	3600		
8000	66,32	22		39	18	13	9,7	6,4	4,8	55500	4030		
8000	76,59	19		34	16	11	8,4	5,5	4,2	55500	4219		
8000	88,57	16		29	14	9,6	7,3	4,8	3,6	55500	4332		
8000	99,00	15		26	12	8,6	6,5	4,3	3,2	55500	4386		
8000	111,63	13		23	11	7,6	5,8	3,8	2,9	55500	4437		
8000	127,11	11	KT774	21	10	6,8	5,2	3,4	2,6	55000	-	370	542
8000	142,56	10		18	9,2	6,0	4,6	3,0	2,3	55000	-		
8000	160,70	9,0		16	8,2	5,4	4,1	2,7	2,0	55000	-		
8000	182,29	8,0		14	7,2	4,7	3,6	2,4	1,8	55000	-		
8000	208,42	7,0		13	6,3	4,2	3,2	2,1	1,6	55000	530		
8000	240,71	6,0		11	5,5	3,6	2,7	1,8	1,4	55000	1265		
8000	278,35	5,2		9,5	4,7	3,1	2,4	1,6	1,2	55000	1628		
8000	311,14	4,7		8,5	4,3	2,8	2,1	1,4	1,1	55000	1663		
8000	354,32	4,1		7,5	3,7	2,4	1,9	1,2	0,93	55000	1694		
8000	396,00	3,7		6,7	3,3	2,2	1,7	1,1	0,83	55000	1647		

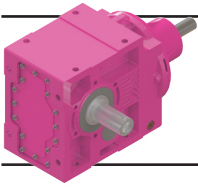

K Serisi Motorsuz Güç Devir Sayfaları

K Series Gear Units Performance Tables

K Serien Getriebe Leistung und Drehzahlübersicht

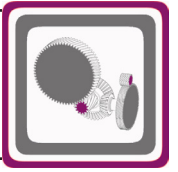

Anma Momenti Nominal Torques Nenn-drehmomente Ma [Nm] (n1=1450rpm)	Çevrim Oranı	Çıkış Devri	Tipi	Pe= Nominal Güç [kW] (Servis Faktörü fs=1,0 için)						Güv. Rad.Yük Çıkış	Güv.Rad.Yük Giriş	Ağırlık	Ölçü Sayfası
	Ratio	Output Speeds		Type	Pe= Nominal Power [kW] (For Service Factor fs=1,0)								
	Übersetzung	Abtriebs-drehzahlen	Typ	Giriş devri[d/d] / Input speed[rpm] / Antriebsdrehzahl[upm]						Zul.Querkräfte (Abtrieb)	Zul.Querkräfte (Antrieb)	Gewicht	Maße Seite
	i	n2 [r.p.m] (n1=1450rpm)		n1=2900	n1=1450	n1=950	n1=725	n1=475	n1=360	Fqam [N] (n1=1450rpm)	Fqem [N] (n1=1450rpm)	[kg]	
8000	436,74	3,3	KT775	6,2	3,1	2,0	1,5	1,0	0,77	55000	1746	381	546
8000	504,65	2,9		5,4	2,7	1,8	1,3	0,88	0,67	55000	1771		
8000	547,17	2,7		5,0	2,5	1,6	1,2	0,81	0,62	55000	1786		
8000	655,11	2,2		4,2	2,1	1,4	1,0	0,68	0,52	55000	1810		
8000	746,01	1,9		3,7	1,8	1,2	0,91	0,60	0,45	55000	1826		
8000	833,78	1,7		3,3	1,6	1,1	0,82	0,54	0,41	55000	1839		
8000	943,49	1,5		2,9	1,4	0,95	0,72	0,47	0,36	55000	1851		
8000	1058,16	1,4		2,6	1,3	0,85	0,65	0,42	0,32	55000	1892		
8000	1192,77	1,2		2,3	1,1	0,75	0,57	0,38	0,28	55000	1930		
8000	1353,02	1,1		2,0	1,0	0,66	0,51	0,33	0,25	55000	1966		
8000	1547,01	0,94		1,8	0,88	0,58	0,44	0,29	0,24	55000	2000		
8000	1786,65	0,81		1,5	0,77	0,50	0,38	0,25	0,21	55000	2031		
8000	2066,04	0,70		1,3	0,66	0,43	0,33	0,24	0,18	55000	2058		
8000	1941,39	0,75	KT776	1,4	0,72	0,47	0,36	0,26	0,20	55000	2124	386	546
8000	2145,24	0,68		1,3	0,65	0,43	0,33	0,24	0,18	55000	2129		
8000	2503,73	0,58		1,1	0,56	0,37	0,28	0,20	0,15	55000	2135		
8000	2944,95	0,49		0,95	0,48	0,31	0,26	0,17	0,13	55000	2141		
8000	3501,26	0,41		0,80	0,40	0,26	0,22	0,15	0,11	55000	2146		
8000	3960,44	0,37		0,71	0,35	0,26	0,20	0,13	0,10	55000	2150		
8000	4516,30	0,32		0,62	0,31	0,23	0,17	0,11	0,09	55000	2153		
8000	5610,63	0,26		0,50	0,25	0,18	0,14	0,09	0,07	55000	2157		
8000	6380,72	0,23		0,49	0,25	0,18	0,14	0,09	0,07	55000	2159		
8000	7156,22	0,20		0,44	0,22	0,16	0,12	0,08	0,06	55000	2167		
8000	8066,59	0,18		0,39	0,19	0,14	0,11	0,07	0,05	55000	2174		
8000	9150,37	0,16		0,34	0,17	0,13	0,10	0,06	0,05	55000	2181		
8000	10462,31	0,14		0,30	0,15	0,11	0,08	0,05	0,04	55000	2188		
8000	12082,94	0,12		0,26	0,13	0,09	0,07	0,05	0,04	55000	2194		
8000	13972,49	0,10		0,25	0,11	0,08	0,06	0,04	0,03	55000	2199		
8000	15618,73	0,09		0,22	0,10	0,07	0,06	0,04	0,03	55000	2202		
7850	9,63	151	KT873	-	132	98	77	51	38	59317	-	615	550
8100	11,05	131		-	118	88	67	44	33	62056	-		
8350	12,25	118		-	110	80	61	40	30	64010	-		
8650	13,93	104		-	100	70	53	35	26	66615	-		
12600	16,78	86		-	121	91	72	47	36	64685	-		
13100	19,26	75		-	110	82	63	41	31	67491	-		
13550	21,34	68		-	103	74	57	37	28	69502	-		
14100	24,28	60		-	94	65	50	33	25	72195	-		
13300	29,88	49		-	72	53	41	27	20	81282	-		
13800	34,28	42		-	65	46	35	23	18	84864	-		
14250	38,00	38		-	61	42	32	21	16	85187	-		
14750	43,22	34		-	55	37	28	18	14	80404	-		
15000	49,75	29		-	49	32	24	16	12	76000	-		
15000	55,53	26		-	44	29	22	14	11	76000	-		
15000	62,42	23		-	39	25	19	13	9,6	76000	-		
15000	70,76	20		63	34	22	17	11	8,5	76000	-		
15000	81,06	18		57	30	20	15	9,8	7,4	76000	-		
15000	92,80	16		52	26	17	13	8,6	6,5	76000	-		
15000	103,24	14		47	23	15	12	7,7	5,8	76000	-		
15000	115,87	13		42	21	14	10	6,8	5,2	76000	-		
15000	86,63	17	KT874	56	28	18	14	9,2	7,0	76000	-	630	554
15000	98,53	15		50	25	16	12	8,1	6,2	76000	-		
15000	113,42	13		43	22	14	11	7,1	5,4	76000	-		
15000	126,62	11		39	19	13	9,7	6,3	4,8	76000	-		
15000	142,32	10		34	17	11	8,6	5,6	4,3	76000	-		
15000	161,34	9,0		30	15	10,0	7,6	5,0	3,8	76000	175		
15000	184,83	7,8		27	13	8,7	6,7	4,4	3,3	76000	1361		
15000	207,95	7,0		24	12	7,8	5,9	3,9	2,9	76000	1664		
15000	235,47	6,2		21	10	6,9	5,2	3,4	2,6	76000	1948		
15000	287,10	5,1		17	8,6	5,6	4,3	2,8	2,1	76000	2311		
15000	339,70	4,3		15	7,3	4,8	3,6	2,4	1,8	76000	2584		
15000	383,99	3,8		13	6,5	4,2	3,2	2,1	1,6	76000	2648		
15000	438,70	3,3		11	5,7	3,7	2,8	1,9	1,4	76000	2688		

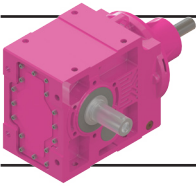

K Serisi Motorsuz Güç Devir Sayfaları

K Series Gear Units Performance Tables

K Serien Getriebe Leistung und Drehzahlübersicht

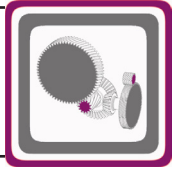

Anma Momenti <i>Nominal Torques</i> Nenn-drehmomente Ma [Nm] (n1=1450rpm)	Çevrim Oranı	Çıkış Devri	Tipi	Pe= Nominal Güç [kW] (Servis Faktörü fs=1,0 için)						Güv. Rad.Yük Çıkış	Güv.Rad.Yük Giriş	Ağırlık	Ölçü Sayfası
	Ratio	Output Speeds		Type	Pe= Nominal Power [kW] (For Service Factor fs=1,0)								
	Übersetzung	Abtriebs-drehzahlen	Typ	Giriş devri[d/d] / Input speed[rpm] / Antriebsdrehzahl[upm]						Zul.Querkräfte (Abtrieb)	Zul.Querkräfte (Antrieb)	Gewicht	Maße Seite
	i	n2 [r.p.m] (n1=1450rpm)	n1=2900	n1=1450	n1=950	n1=725	n1=475	n1=360	Fqam [N] (n1=1450rpm)	Fqem [N] (n1=1450rpm)	[kg]		
15000	463,83	3,1	KT875	11	5,5	3,6	2,7	1,8	1,4	76000	695	640	558
15000	514,05	2,8		9,9	4,9	3,2	2,5	1,6	1,2	76000	1122		
15000	584,66	2,5		8,7	4,3	2,8	2,2	1,4	1,1	76000	1448		
15000	673,01	2,2		7,5	3,8	2,5	1,9	1,2	0,94	76000	1551		
15000	751,30	1,9		6,8	3,4	2,2	1,7	1,1	0,84	76000	1622		
15000	844,51	1,7		6,0	3,0	2,0	1,5	0,99	0,75	76000	1690		
15000	957,34	1,5		5,3	2,7	1,7	1,3	0,87	0,66	76000	1754		
15000	1096,71	1,3		4,6	2,3	1,5	1,2	0,76	0,58	76000	1814		
15000	1313,07	1,1		3,9	1,9	1,3	0,97	0,64	0,48	76000	1838		
15000	1495,27	0,97		3,4	1,7	1,1	0,86	0,56	0,42	76000	1852		
15000	1671,18	0,87		3,1	1,5	1,0	0,77	0,50	0,38	76000	1865		
15000	1891,08	0,77		2,7	1,4	0,89	0,68	0,44	0,34	76000	1875		
15000	2074,42	0,70		KT876	2,5	1,3	0,83	0,63	0,41	0,31	76000		
15000	2387,89	0,61	2,2		1,1	0,72	0,55	0,36	0,27	76000	2067		
15000	2665,68	0,54	2,0		0,98	0,64	0,49	0,32	0,27	76000	2085		
15000	2996,39	0,48	1,7		0,87	0,57	0,44	0,29	0,24	76000	2101		
15000	3396,71	0,43	1,5		0,77	0,50	0,39	0,25	0,21	76000	2116		
15000	3891,23	0,37	1,3		0,67	0,44	0,34	0,24	0,19	76000	2131		
15000	4299,81	0,34	1,2		0,61	0,40	0,30	0,22	0,17	76000	2136		
15000	5018,35	0,29	1,0		0,52	0,34	0,26	0,19	0,14	76000	2142		
15000	5902,70	0,25	0,89		0,45	0,29	0,25	0,16	0,12	76000	2147		
15000	7017,76	0,21	0,75		0,38	0,27	0,21	0,14	0,10	76000	2152		
15000	7938,12	0,18	0,67		0,33	0,24	0,18	0,12	0,09	76000	2155		
15000	9052,24	0,16	0,58		0,29	0,21	0,16	0,11	0,08	76000	2158		
15000	11245,67	0,13	0,52		0,26	0,19	0,15	0,10	0,07	76000	2162		
15000	12789,19	0,11	0,46	0,23	0,17	0,13	0,08	0,06	76000	2164			
11300	11,69	124	KT973	252	153	115	93	71	58	77710	20760	1045	562
11600	13,06	111		232	140	106	85	65	53	80410	20630		
11950	14,65	99		213	129	97	78	60	47	83470	20500		
12300	16,51	88		194	118	89	72	54	42	86610	20370		
12680	18,73	77		176	107	81	65	50	38	90120	20240		
19120	22,05	66		232	137	91	70	47	36	77500	20630		
19200	24,73	59		212	123	82	63	42	32	77500	20500		
19280	27,88	52		194	109	73	56	37	28	77500	20380		
19380	31,63	46		177	97	65	50	33	25	76500	20270		
19510	38,21	38		147	82	54	42	27	21	75500	20430		
19600	42,86	34		135	73	49	37	24	19	75000	20360		
19700	48,31	30		124	65	43	33	22	16	74500	20290		
19800	54,80	26		112	58	38	29	19	14	74000	20220		
19940	64,28	23		96	50	33	25	16	12	73500	20150		
20000	71,60	20		87	45	29	22	15	11	73500	20100		
20000	80,31	18		78	40	26	20	13	9,9	73500	20060		
20000	90,85	16		69	35	23	18	12	8,7	73500	20020		
20000	103,87	14		61	31	20	16	10	7,7	73500	19980		
20000	117,32	12		55	28	18	14	9,0	6,8	73500	19950		
20000	130,38	11		49	25	16	12	8,1	6,2	73500	19930		
20000	146,20	9,9	44	22	14	11	7,2	5,5	73500	19900			
20000	134,57	11	KT974	49	24	16	12	7,9	6,0	73500	-	1070	566
20000	151,03	9,6		43	22	14	11	7,1	5,4	73500	-		
20000	168,94	8,6		39	19	13	9,7	6,4	4,8	73500	-		
20000	181,51	8,0		36	18	12	9,0	5,9	4,5	73500	-		
20000	238,77	6,1		28	14	9,0	6,9	4,5	3,4	73500	5760		
20000	269,15	5,4		24	12	8,0	6,1	4,0	3,0	73500	6120		
20000	305,31	4,7		22	11	7,1	5,4	3,5	2,7	73500	6020		
20000	358,16	4,0		18	9,2	6,0	4,6	3,0	2,3	73500	5880		
20000	398,92	3,6		17	8,3	5,4	4,1	2,7	2,1	73500	5790		
20000	361,44	4,0	KT975	19	9,3	6,1	4,7	3,0	2,3	73500	2970	1090	570
20000	427,72	3,4		16	7,9	5,2	3,9	2,6	2,0	73500	2910		
20000	460,51	3,1		15	7,3	4,8	3,7	2,4	1,8	73500	2890		

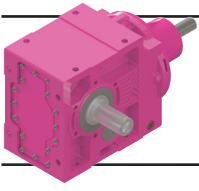

K Serisi Motorsuz Güç Devir Sayfaları

K Series Gear Units Performance Tables

K Serien Getriebe Leistung und Drehzahlübersicht

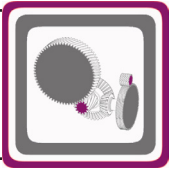

Anma Momenti <i>Nominal Torques</i> Nenn-drehmomente Ma [Nm] (n1=1450rpm)	Çevrim Oranı	Çıkış Devri	Tipi	Pe= Nominal Güç [kW] (Servis Faktörü fs=1,0 için)						Güv. Rad.Yük Çıkış <i>Per.O.Loads (Output)</i>	Güv.Rad.Yük Giriş <i>Per.O.Loads (Input)</i>	Ağırlık <i>Weight</i> Gewicht [kg]	Ölçü Sayfası <i>Dim. Page</i> Maße Seite
	Ratio	Output Speeds		Type	Pe= NennLeistung [kW] (Bei Betriebsfaktor fs=1,0)								
	Übersetzung	Abtriebs-drehzahlen	Typ	Giriş devri[d/d] / Input speed[rpm] / Antriebsdrehzahl[upm]									
	i	n2 [r.p.m] (n1=1450rpm)		n1=2900	n1=1450	n1=950	n1=725	n1=475	n1=360	Fqam [N] (n1=1450rpm)	Fqem [N] (n1=1450rpm)		
20000	518,12	2,8	KT975	13	6,5	4,3	3,3	2,1	1,6	73500	3320	1090	570
20000	586,70	2,5		12	5,8	3,8	2,9	1,9	1,4	73500	3260		
20000	659,09	2,2		10	5,1	3,4	2,6	1,7	1,3	73500	3230		
20000	715,34	2,0		9,5	4,7	3,1	2,4	1,5	1,2	73500	3200		
20000	846,39	1,7		8,0	4,0	2,6	2,0	1,3	0,99	73500	3170		
20000	949,26	1,5		7,2	3,6	2,3	1,8	1,2	0,89	73500	3150		
20000	1070,02	1,4		6,3	3,2	2,1	1,6	1,0	0,79	73500	3130		
20000	1213,78	1,2		5,6	2,8	1,8	1,4	0,92	0,70	73500	3100		
20000	1423,89	1,0		4,8	2,4	1,6	1,2	0,78	0,59	73500	3060		
20000	1585,92	0,91		4,3	2,1	1,4	1,1	0,70	0,53	73500	2650		
20000	1985,89	0,73	KT976	3,5	1,7	1,1	0,87	0,57	0,43	73500	2800	1090	570
20000	2218,31	0,65		3,1	1,6	1,0	0,78	0,51	0,39	73500	2780		
20000	2348,01	0,62		3,0	1,5	0,97	0,74	0,48	0,37	73500	2780		
20000	2811,23	0,52		2,5	1,2	0,81	0,62	0,41	0,31	73500	2770		
20000	3306,00	0,44		2,1	1,1	0,69	0,53	0,35	0,26	73500	2720		
20000	3499,30	0,41		2,0	1,0	0,65	0,50	0,33	0,27	73500	2720		
20000	4189,63	0,35		1,7	0,83	0,55	0,42	0,27	0,23	73500	2710		
20000	5350,83	0,27		1,3	0,65	0,43	0,33	0,24	0,18	73500	2700		
20000	6741,12	0,22		1,0	0,52	0,34	0,26	0,19	0,14	73500	2680		
20000	8652,97	0,17		0,81	0,41	0,27	0,23	0,15	0,11	73500	2670		
20000	12474,60	0,12		0,56	0,28	0,21	0,16	0,10	0,08	73500	2660		
20000	15680,79	0,09		0,50	0,25	0,18	0,14	0,09	0,07	73500	2650		

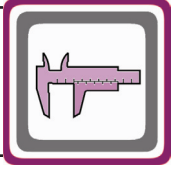
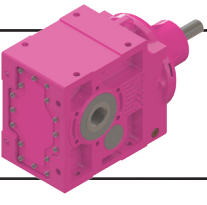

Ölçü Sayfaları

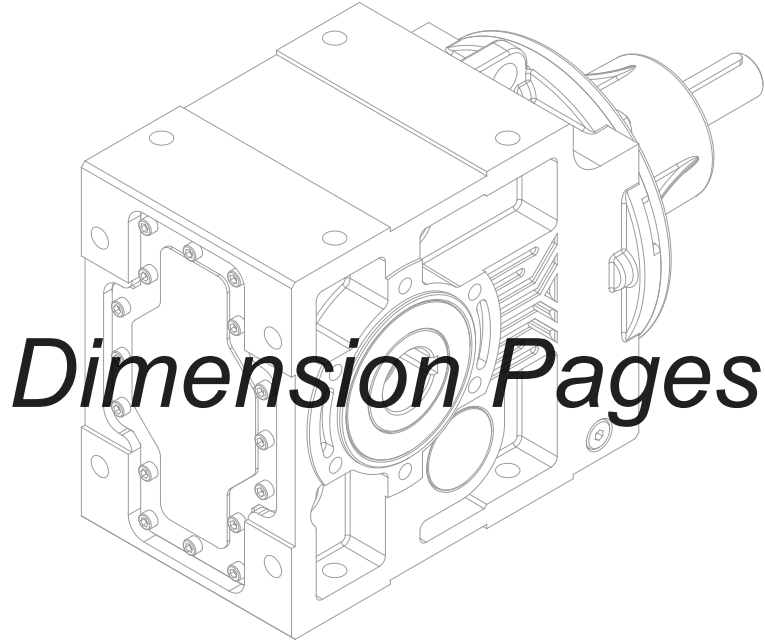

Abmessungenseiten



Ölçü Sayfaları

Dimension Pages

Abmessungsseiten

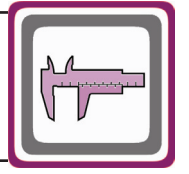

-Mil ucu çektirme deliği DIN 332 sayfa 2 / Tapped center hole to DIN 332, sheet 2 / Zentrierung mit Gewinde DIN 332, Blatt 2

KT002.00
KT003.00

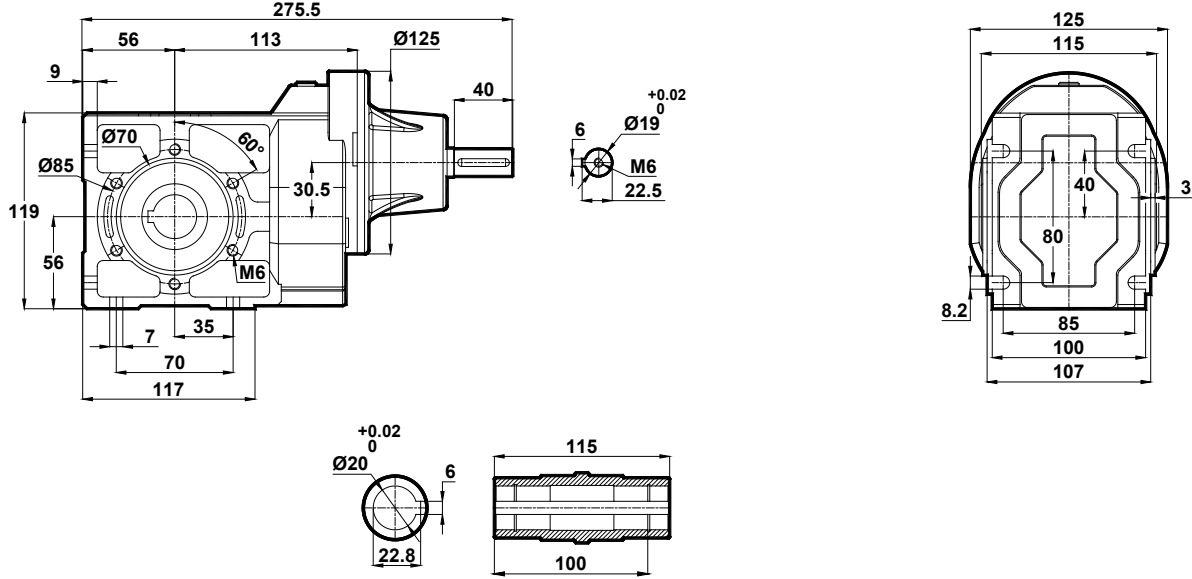

KT002.01
KT003.01

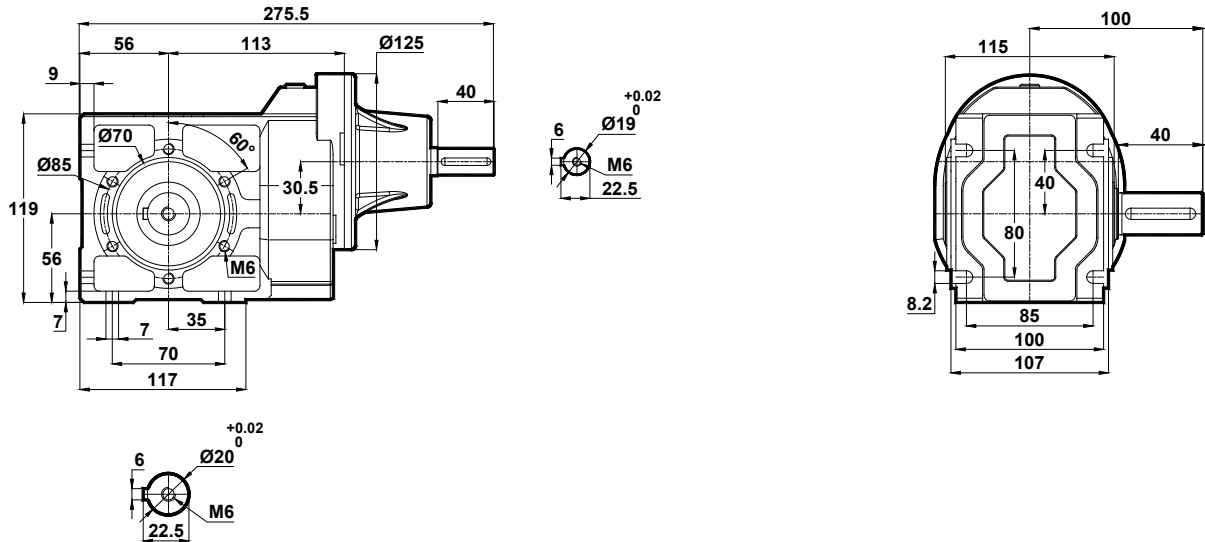



Ölçü Sayfaları Dimension Pages Abmessungsseiten



-Mil ucu çekirme deliği DIN 332 sayfa 2 / Tapped center hole to DIN 332, sheet 2 / Zentrierung mit Gewinde DIN 332, Blatt 2

KT002.02
KT003.02

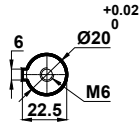
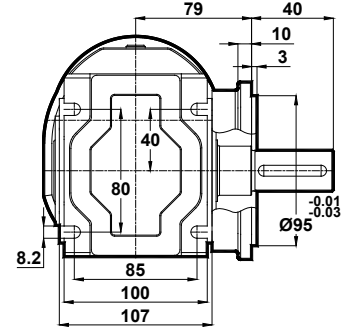
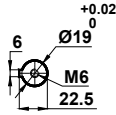
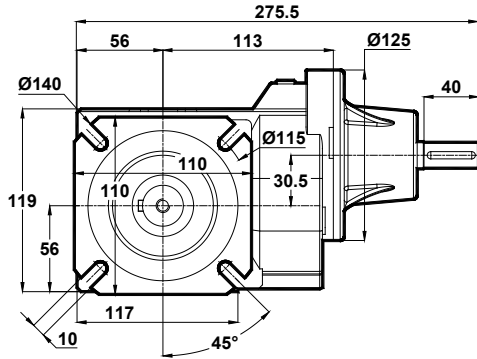

Opsiyonel flanş ölçüleri için sayfa 587'ye bakınız.
Please see on page 587 for optional flange dimensions
Siehe Seite 587 für auswählbare Flanschabmessungen

KT002.03
KT003.03

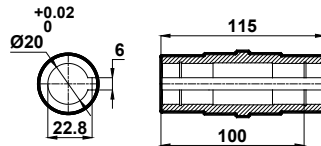
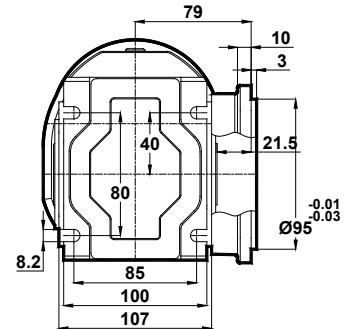
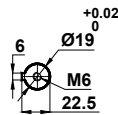
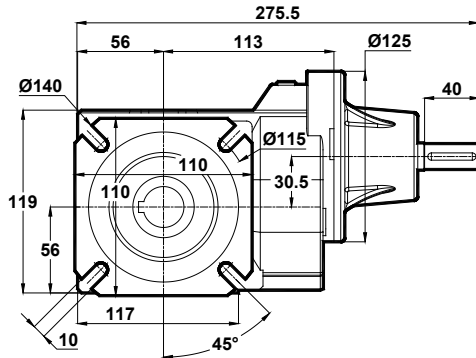

Opsiyonel flanş ölçüleri için sayfa 587'ye bakınız.
Please see on page 587 for optional flange dimensions
Siehe Seite 587 für auswählbare Flanschabmessungen

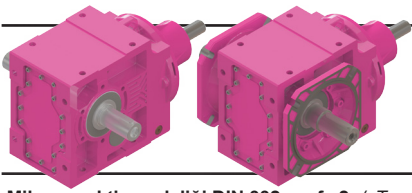

Ölçü Sayfaları Dimension Pages Abmessungsseiten

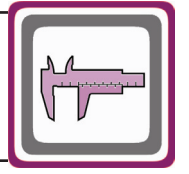

-Mil ucu çekirme deliği DIN 332 sayfa 2 / Tapped center hole to DIN 332, sheet 2 / Zentrierung mit Gewinde DIN 332, Blatt 2

KT002.04
KT003.04

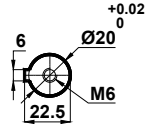
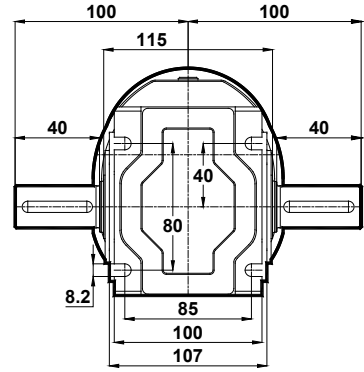
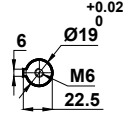
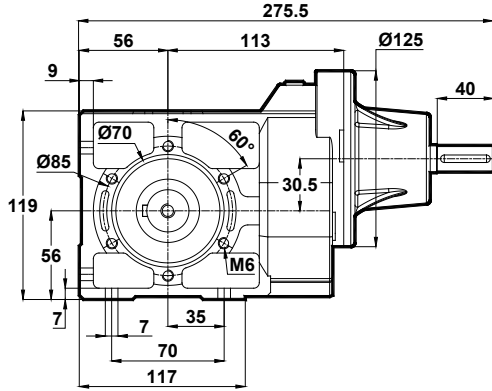

KT002.05
KT003.05

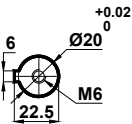
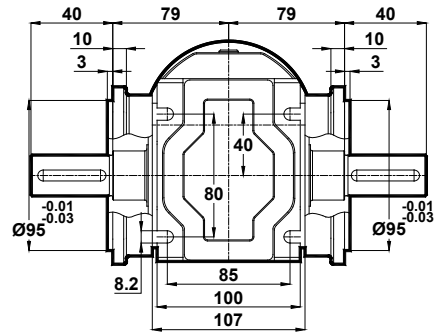
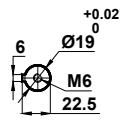
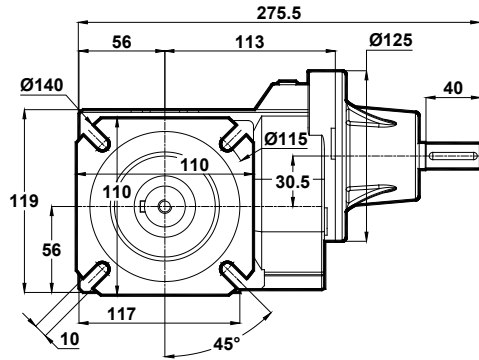

Opsiyonel flanş ölçüleri için sayfa 587'ye bakınız.
Please see on page 587 for optional flange dimensions
Siehe Seite 587 für auswählbare Flanschabmessungen



Ölçü Sayfaları Dimension Pages Abmessungenseiten



-Mil ucu çektirme deliği DIN 332 sayfa 2 / Tapped center hole to DIN 332, sheet 2 / Zentrierung mit Gewinde DIN 332, Blatt 2

KT002.08
KT003.08

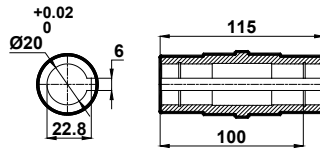
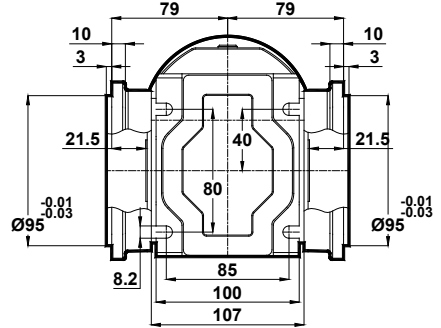
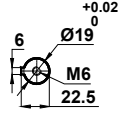
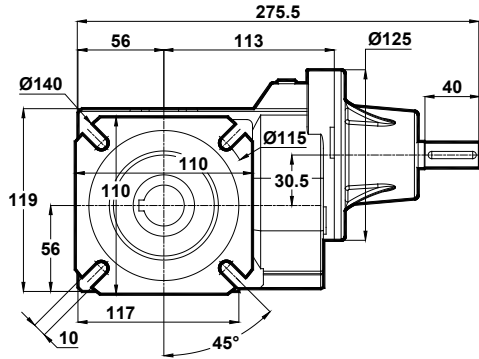

Opsiyonel flanş ölçüleri için sayfa 587'ye bakınız.
Please see on page 587 for optional flange dimensions
Siehe Seite 587 für auswählbare Flanschabmessungen



Ölçü Sayfaları

Dimension Pages

Abmessungsseiten

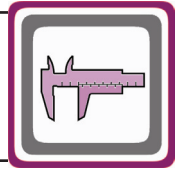

-Mil ucu çekirme deliği DIN 332 sayfa 2 / Tapped center hole to DIN 332, sheet 2 / Zentrierung mit Gewinde DIN 332, Blatt 2

KT102.00
KT103.00

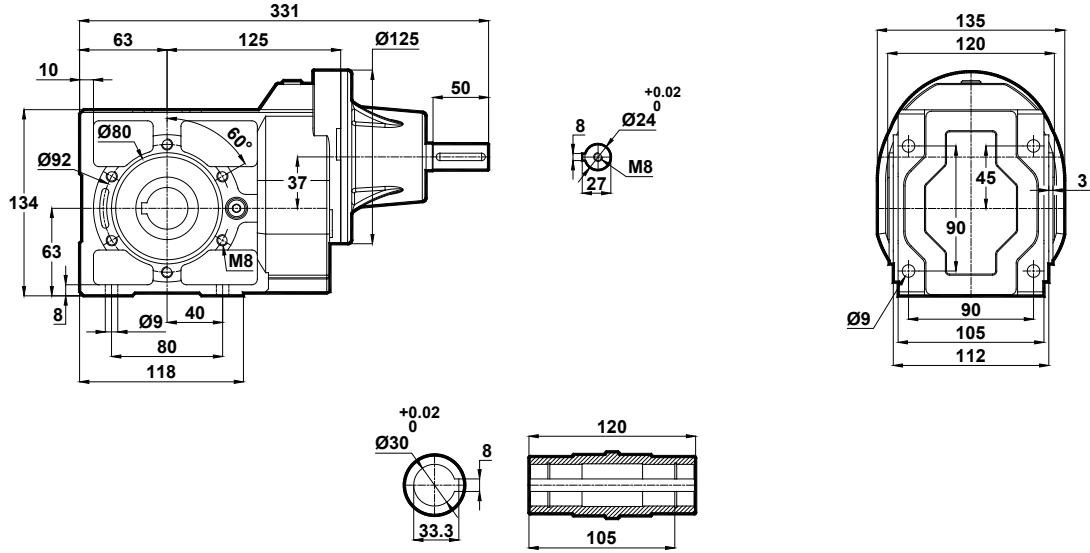

KT102.01
KT103.01

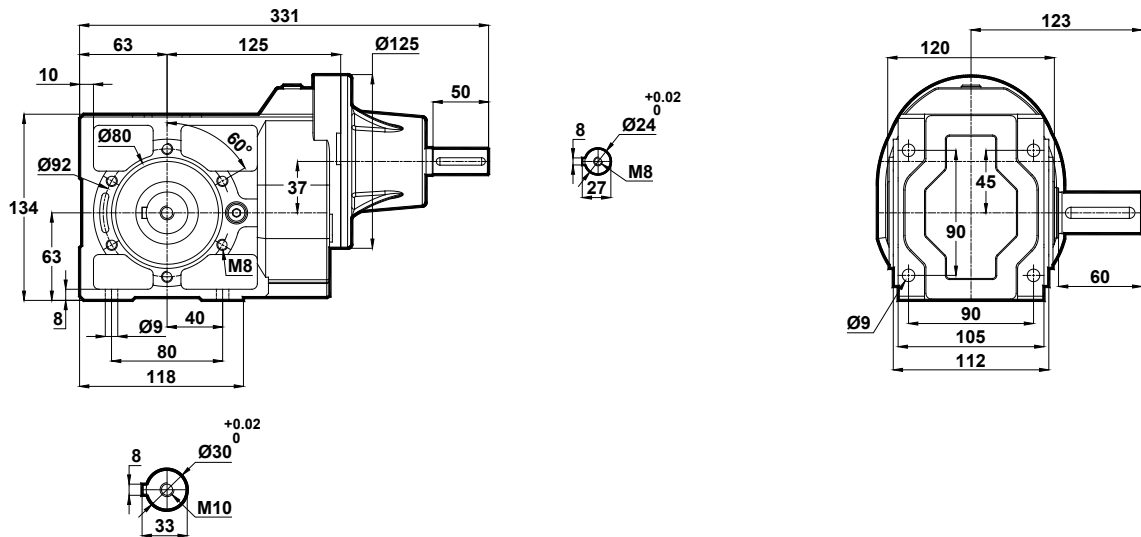



Ölçü Sayfaları

Dimension Pages

Abmessungsseiten



-Mil ucu çekirme deliği DIN 332 sayfa 2 / Tapped center hole to DIN 332, sheet 2 / Zentrierung mit Gewinde DIN 332, Blatt 2

KT102.02
KT103.02

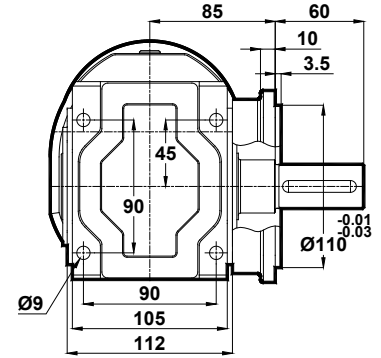
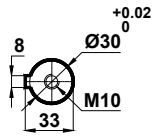
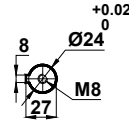
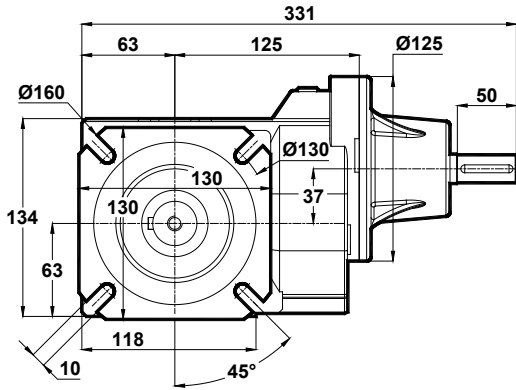

Opsiyonel flanş ölçüleri için sayfa 587'ye bakınız.
Please see on page 587 for optional flange dimensions
Siehe Seite 587 für auswählbare Flanschabmessungen

KT102.03
KT103.03

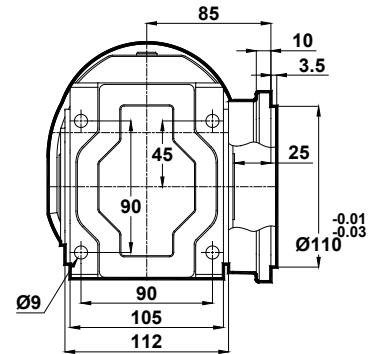
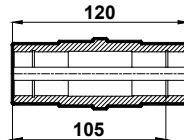
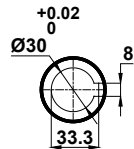
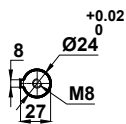
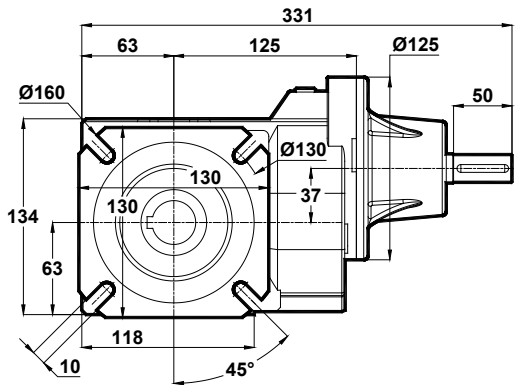

Opsiyonel flanş ölçüleri için sayfa 587'ye bakınız.
Please see on page 587 for optional flange dimensions
Siehe Seite 587 für auswählbare Flanschabmessungen

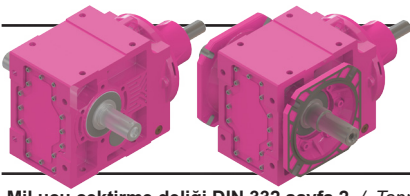

Ölçü Sayfaları Dimension Pages Abmessungsseiten

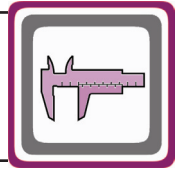

-Mil ucu çekirme deliği DIN 332 sayfa 2 / Tapped center hole to DIN 332, sheet 2 / Zentrierung mit Gewinde DIN 332, Blatt 2

KT102.04
KT103.04

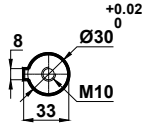
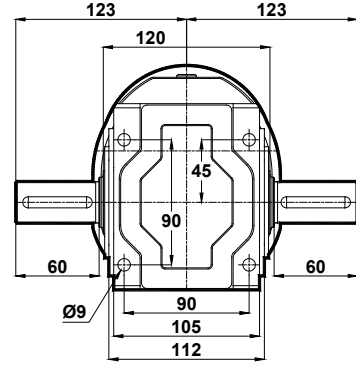
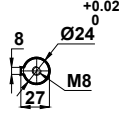
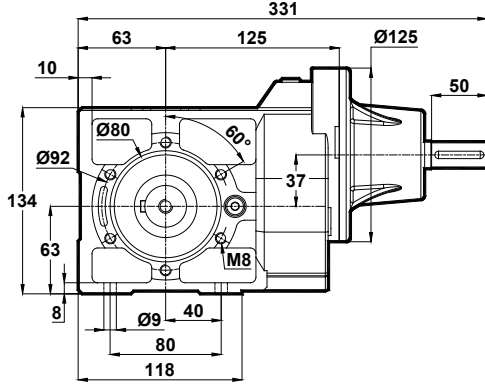

KT102.05
KT103.05

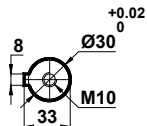
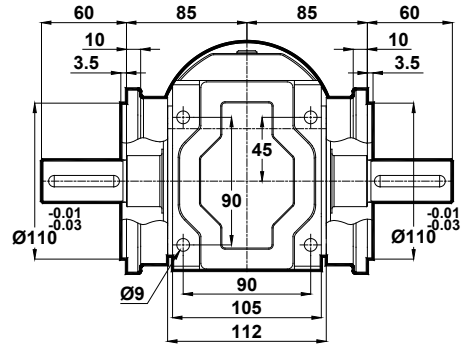
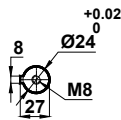
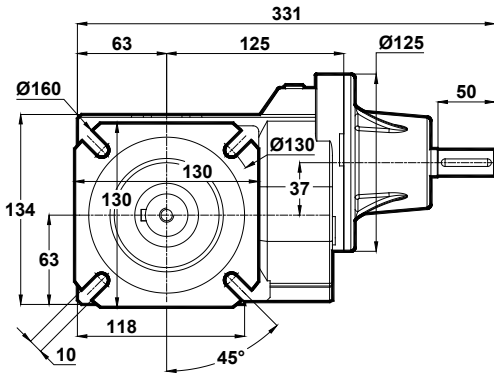

Opsiyonel flanş ölçüleri için sayfa 587'ye bakınız.
Please see on page 587 for optional flange dimensions
Siehe Seite 587 für auswählbare Flanschabmessungen



Ölçü Sayfaları Dimension Pages Abmessungenseiten



-Mil ucu çekirme deliği DIN 332 sayfa 2 / Tapped center hole to DIN 332, sheet 2 / Zentrierung mit Gewinde DIN 332, Blatt 2

KT102.08
KT103.08

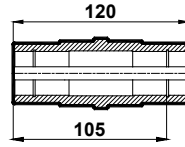
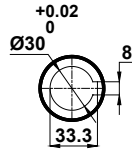
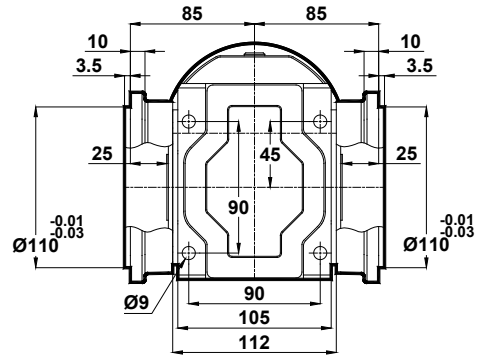
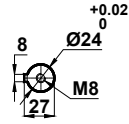
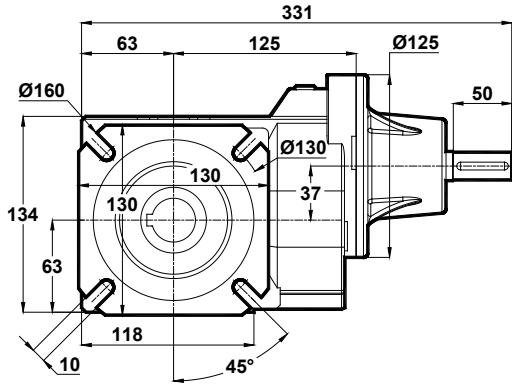

Opsiyonel flanş ölçüleri için sayfa 587'ye bakınız.
Please see on page 587 for optional flange dimensions
Siehe Seite 587 für auswählbare Flanschabmessungen



Ölçü Sayfaları

Dimension Pages

Abmessungenseiten

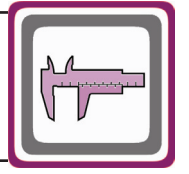

-Mil ucu çekirme deliği DIN 332 sayfa 2 / Tapped center hole to DIN 332, sheet 2 / Zentrierung mit Gewinde DIN 332, Blatt 2

KT202.00
KT203.00

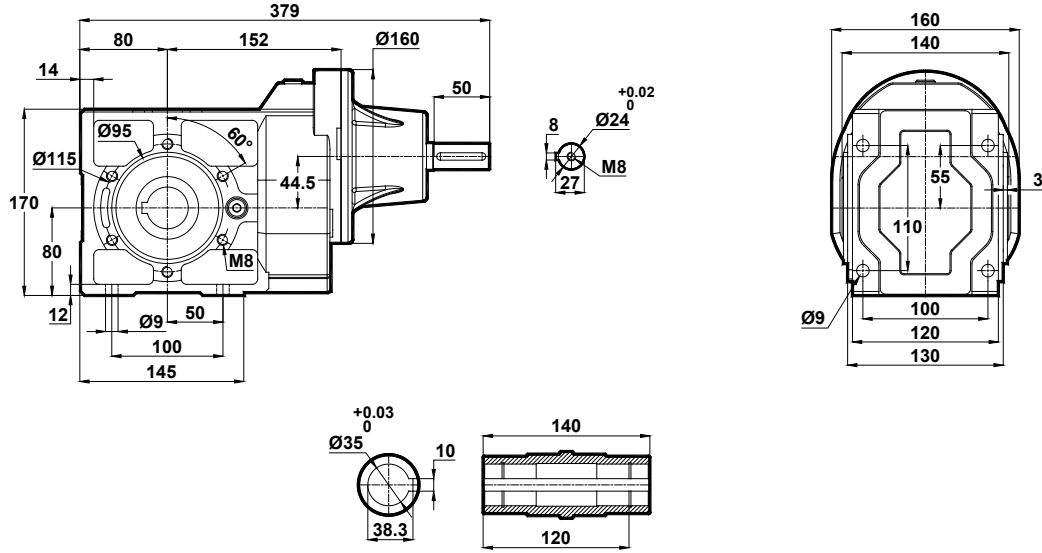

KT202.01
KT203.01

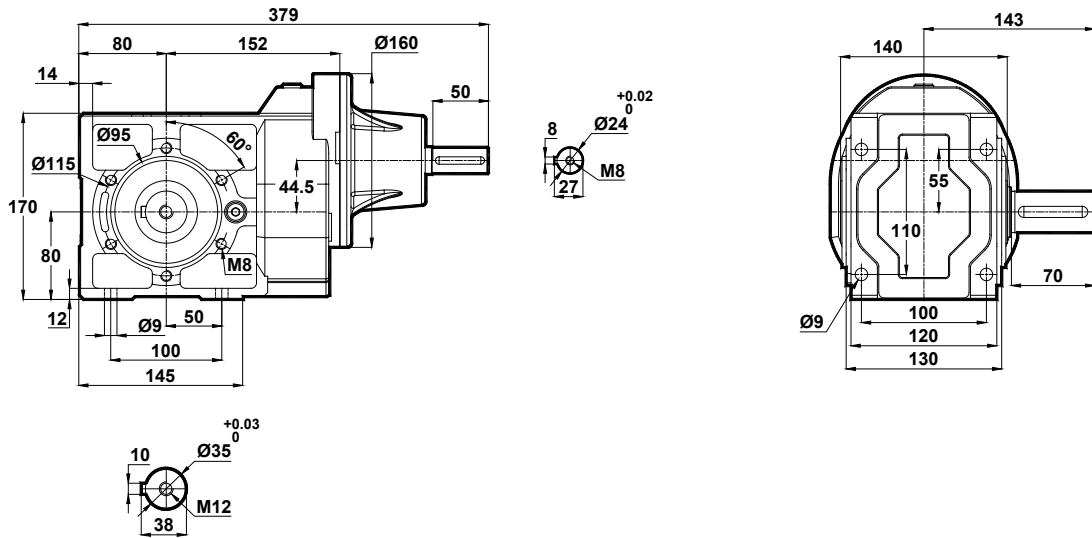



Ölçü Sayfaları Dimension Pages Abmessungenseiten



-Mil ucu çekirme deliği DIN 332 sayfa 2 / Tapped center hole to DIN 332, sheet 2 / Zentrierung mit Gewinde DIN 332, Blatt 2

KT202.02
KT203.02

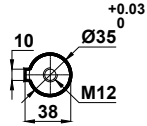
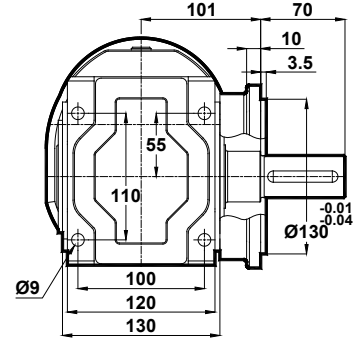
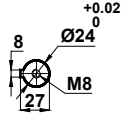
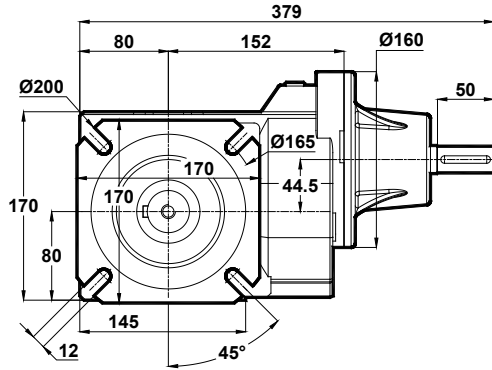

Opsiyonel flanş ölçüleri için sayfa 587'ye bakınız.
Please see on page 587 for optional flange dimensions
Siehe Seite 587 für auswählbare Flanschabmessungen

KT202.03
KT203.03

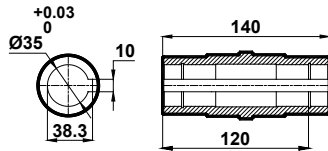
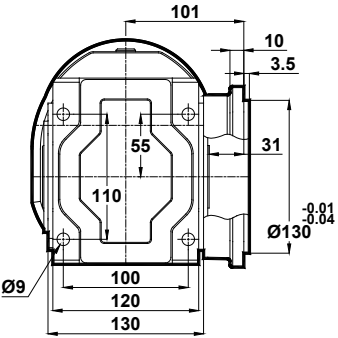
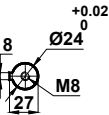
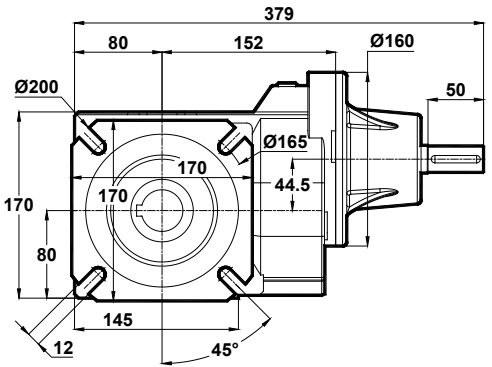

Opsiyonel flanş ölçüleri için sayfa 587'ye bakınız.
Please see on page 587 for optional flange dimensions
Siehe Seite 587 für auswählbare Flanschabmessungen

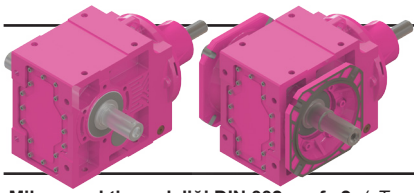

Ölçü Sayfaları Dimension Pages Abmessungsseiten

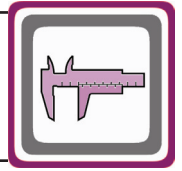

-Mil ucu çektirme deliği DIN 332 sayfa 2 / Tapped center hole to DIN 332, sheet 2 / Zentrierung mit Gewinde DIN 332, Blatt 2

KT202.04
KT203.04

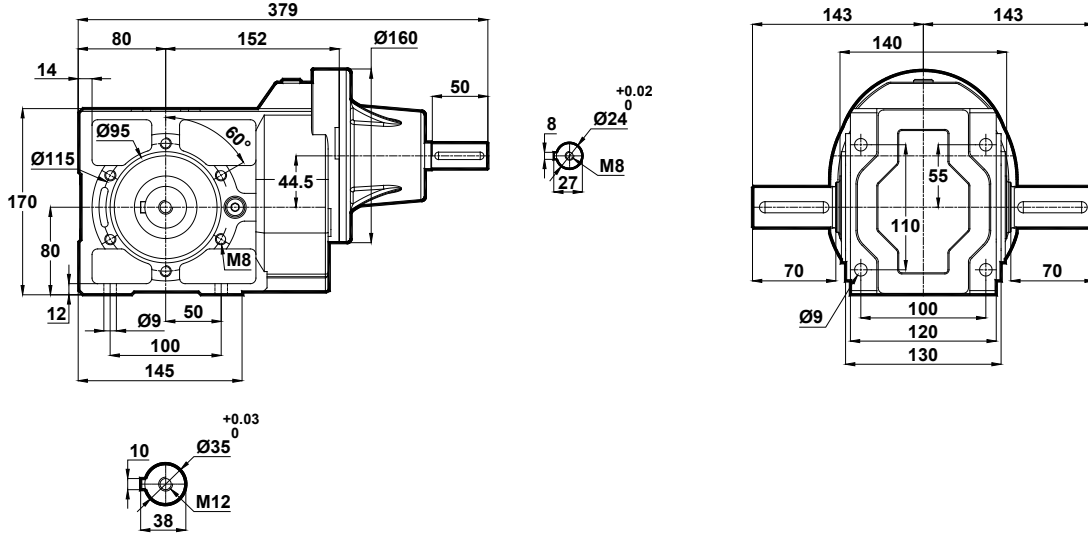

KT202.05
KT203.05

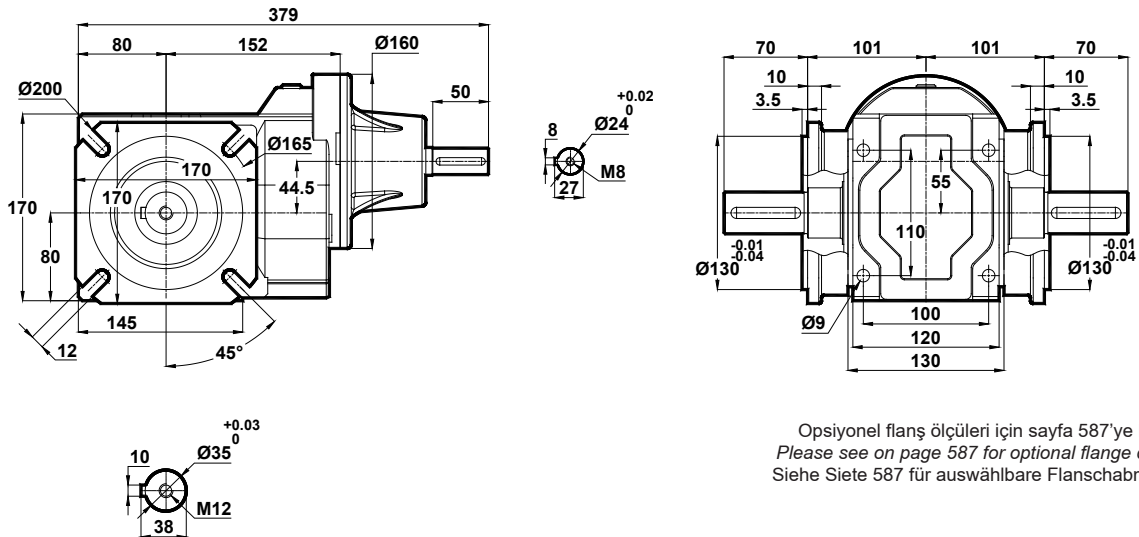

Opsiyonel flanş ölçüleri için sayfa 587'ye bakınız.
Please see on page 587 for optional flange dimensions
Siehe Seite 587 für auswählbare Flanschabmessungen



Ölçü Sayfaları Dimension Pages Abmessungenseiten



-Mil ucu çektirme deliği DIN 332 sayfa 2 / Tapped center hole to DIN 332, sheet 2 / Zentrierung mit Gewinde DIN 332, Blatt 2

KT202.08
KT203.08

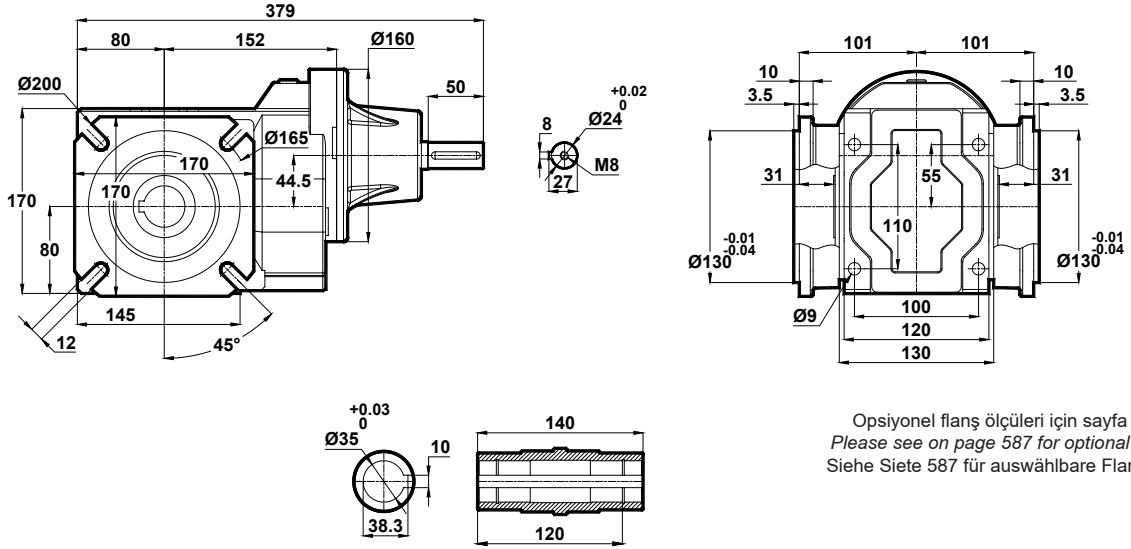

Opsiyonel flanş ölçüleri için sayfa 587'ye bakınız.
Please see on page 587 for optional flange dimensions
Siehe Seite 587 für auswählbare Flanschabmessungen



Ölçü Sayfaları

Dimension Pages

Abmessungsseiten

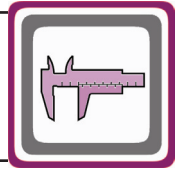

-Mil ucu çekirme deliği DIN 332 sayfa 2 / Tapped center hole to DIN 332, sheet 2 / Zentrierung mit Gewinde DIN 332, Blatt 2

KT273.00

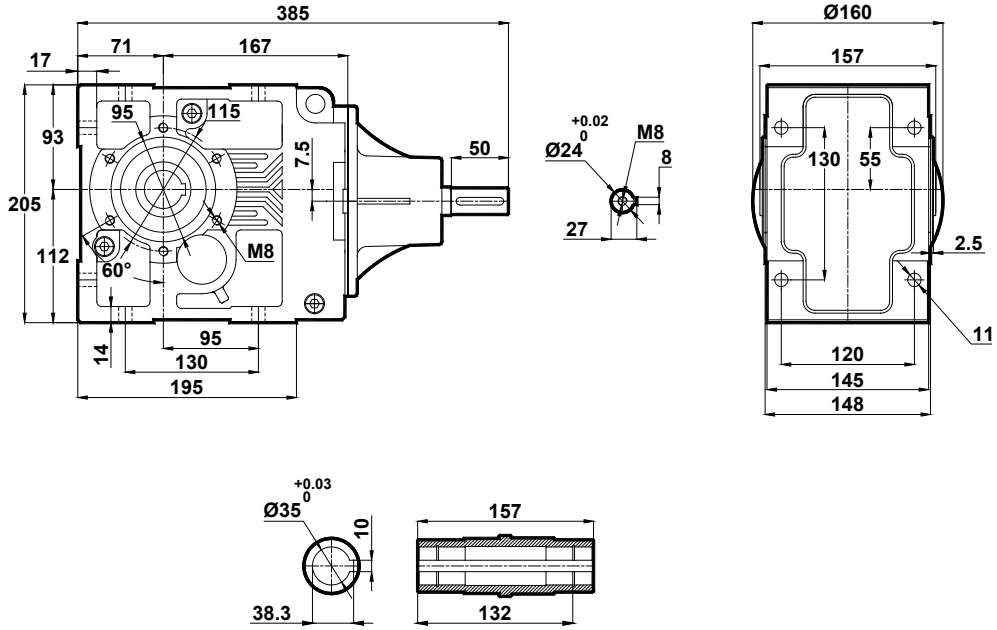

KT273.01

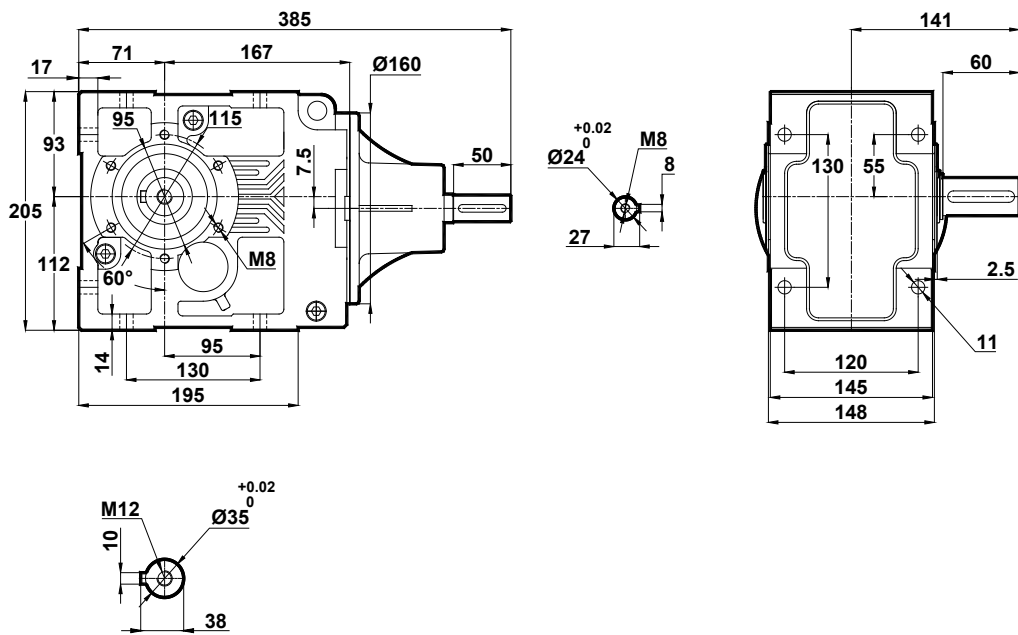



Ölçü Sayfaları Dimension Pages Abmessungenseiten



-Mil ucu çekirme deliği DIN 332 sayfa 2 / Tapped center hole to DIN 332, sheet 2 / Zentrierung mit Gewinde DIN 332, Blatt 2

KT273.02

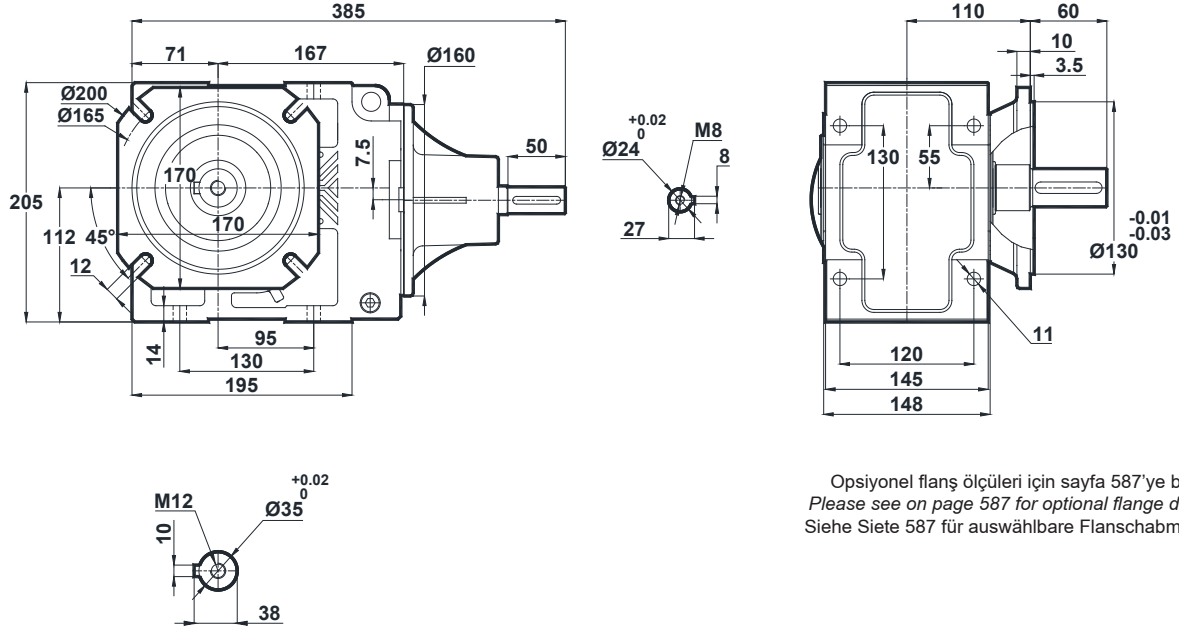

Opsiyonel flanş ölçüleri için sayfa 587'ye bakınız.
Please see on page 587 for optional flange dimensions
Siehe Seite 587 für auswählbare Flanschabmessungen

KT273.03

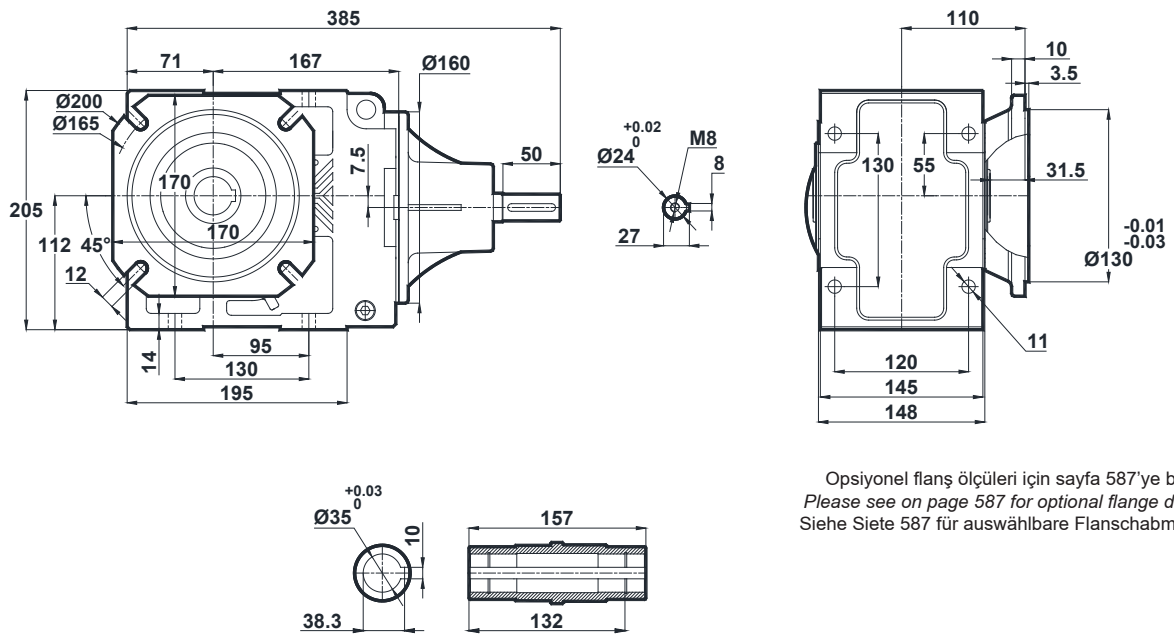

Opsiyonel flanş ölçüleri için sayfa 587'ye bakınız.
Please see on page 587 for optional flange dimensions
Siehe Seite 587 für auswählbare Flanschabmessungen

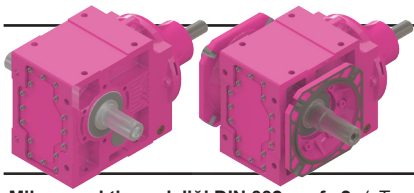

Ölçü Sayfaları

Dimension Pages

Abmessungsseiten

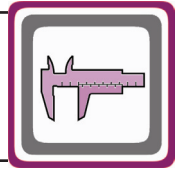

-Mil ucu çektirme deliği DIN 332 sayfa 2 / Tapped center hole to DIN 332, sheet 2 / Zentrierung mit Gewinde DIN 332, Blatt 2

KT273.04

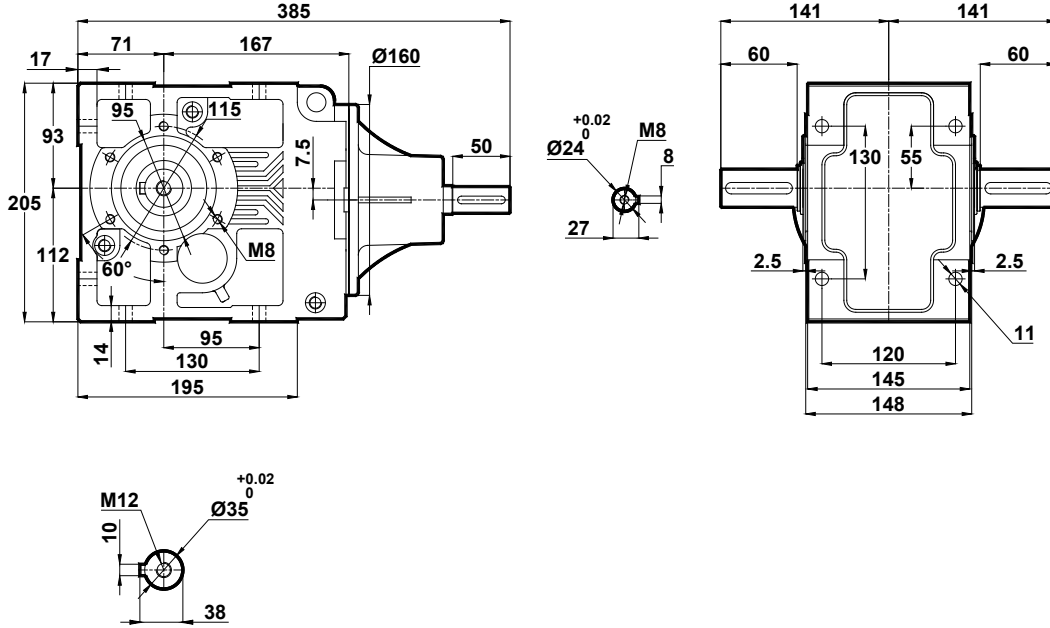

KT273.05

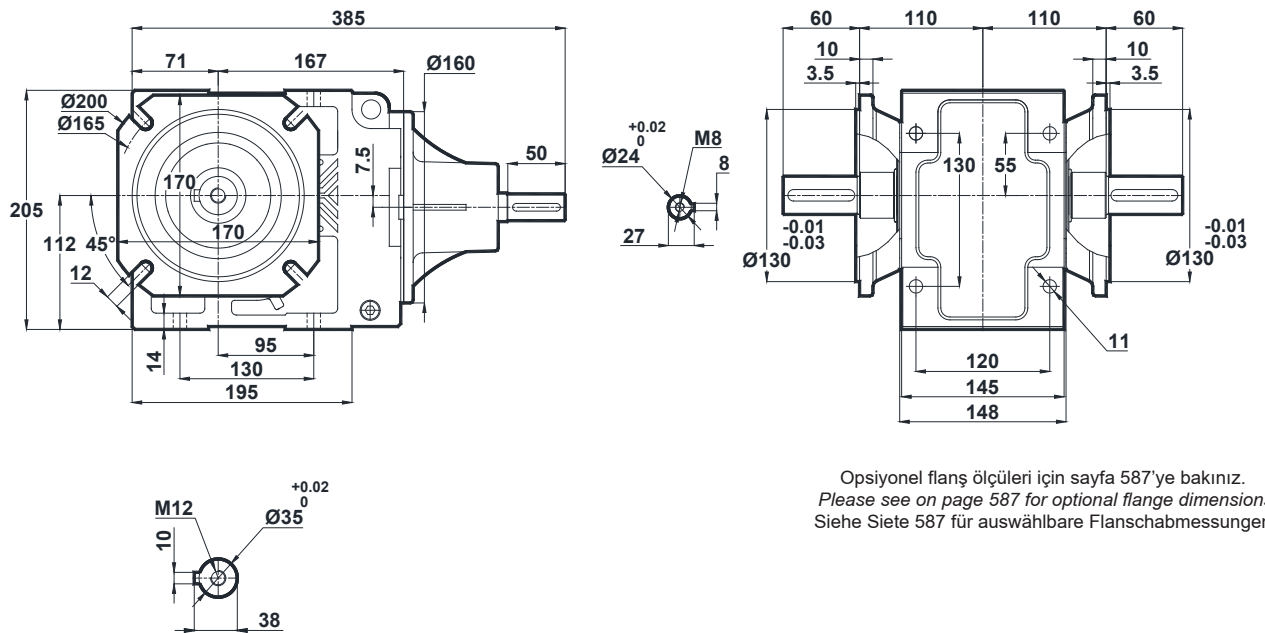



Ölçü Sayfaları Dimension Pages Abmessungsseiten



-Mil ucu çekirme deliği DIN 332 sayfa 2 / Tapped center hole to DIN 332, sheet 2 / Zentrierung mit Gewinde DIN 332, Blatt 2

KT273.08

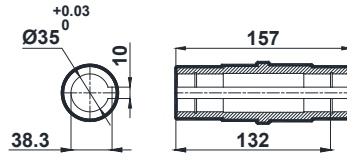
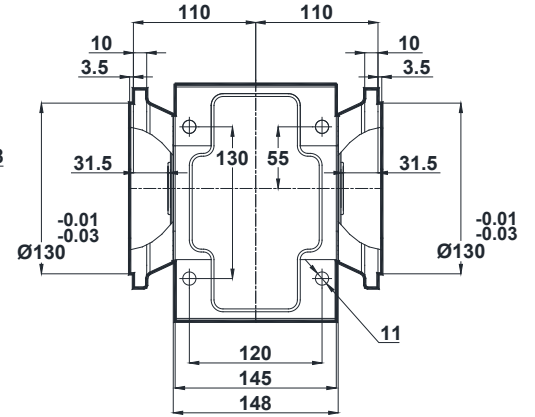
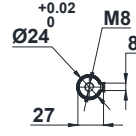
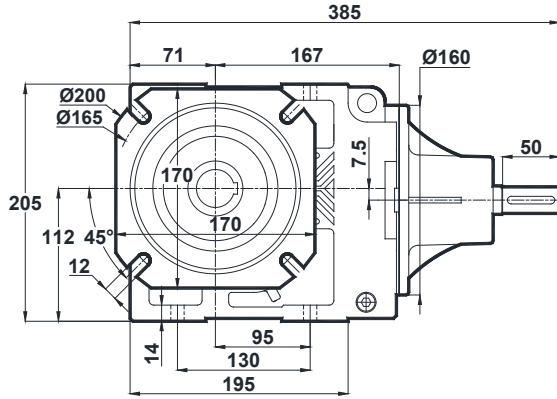

Opsiyonel flanş ölçüleri için sayfa 587'ye bakınız.
Please see on page 587 for optional flange dimensions
Siehe Seite 587 für auswählbare Flanschabmessungen



Ölçü Sayfaları

Dimension Pages

Abmessungsseiten

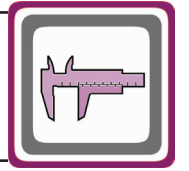

-Mil ucu çekirme deliği DIN 332 sayfa 2 / Tapped center hole to DIN 332, sheet 2 / Zentrierung mit Gewinde DIN 332, Blatt 2

KT275.00
KT276.00

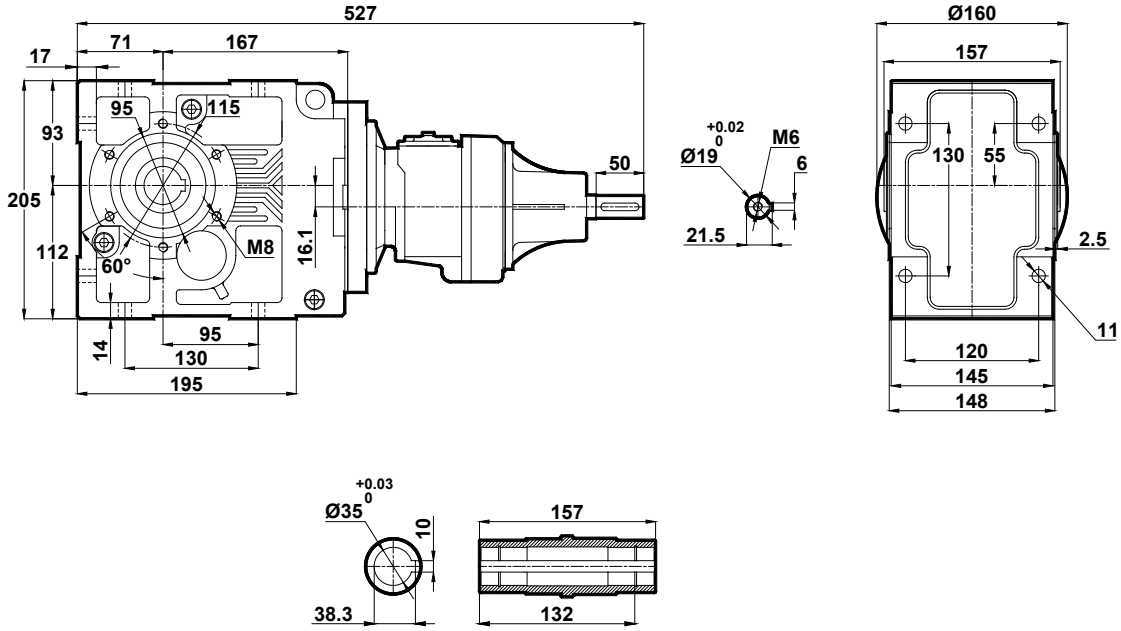

KT275.01
KT276.01

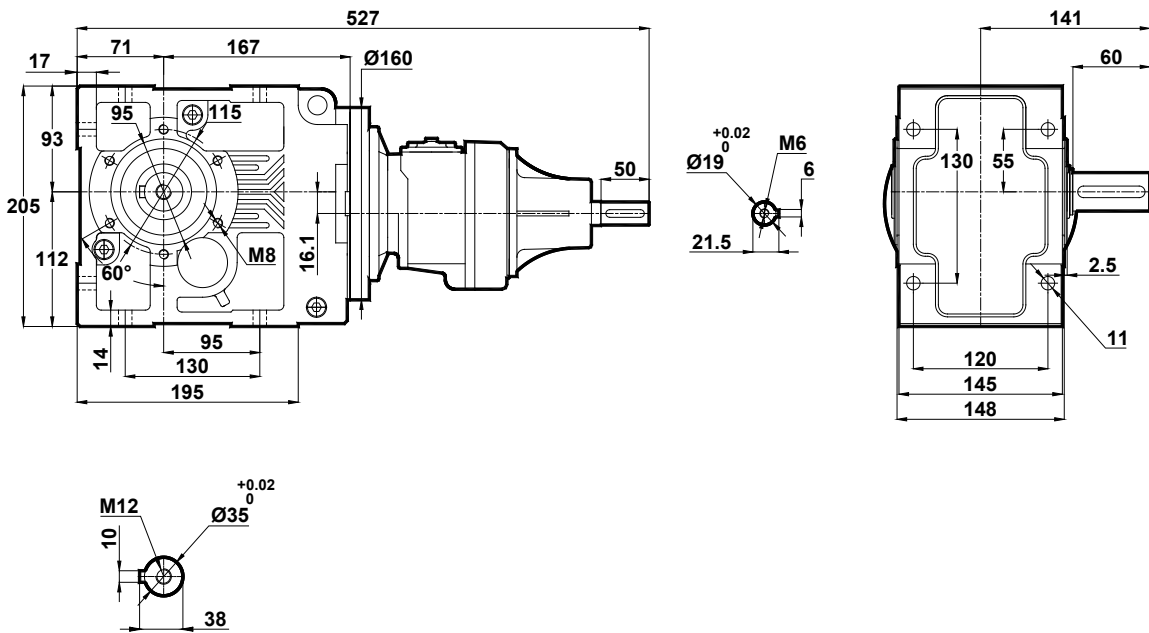



Ölçü Sayfaları Dimension Pages Abmessungenseiten



-Mil ucu çekirme deliği DIN 332 sayfa 2 / Tapped center hole to DIN 332, sheet 2 / Zentrierung mit Gewinde DIN 332, Blatt 2

KT275.02
KT276.02

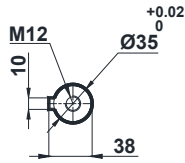
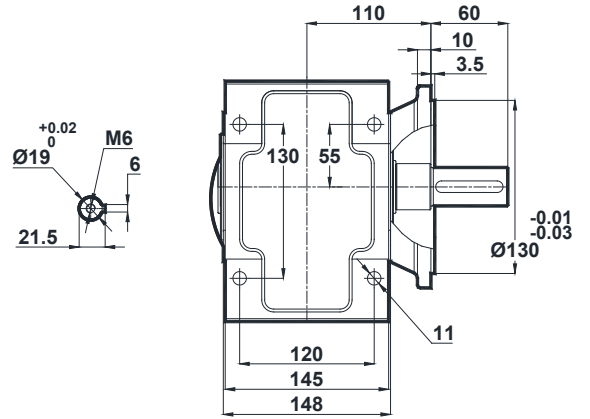
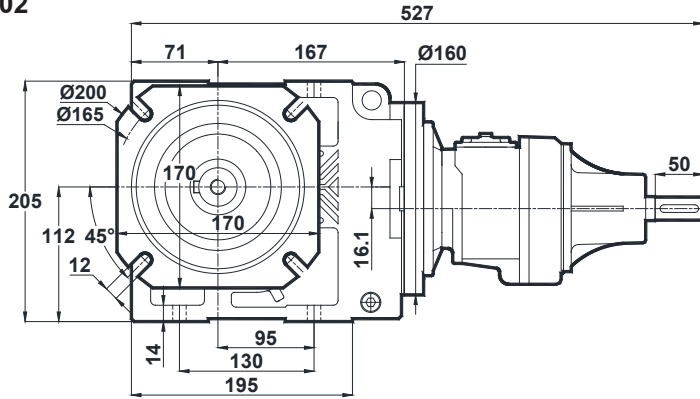

Opsiyonel flanş ölçüleri için sayfa 587'ye bakınız.
Please see on page 587 for optional flange dimensions
Siehe Seite 587 für auswählbare Flanschabmessungen

KT275.03
KT276.03

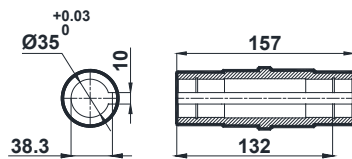
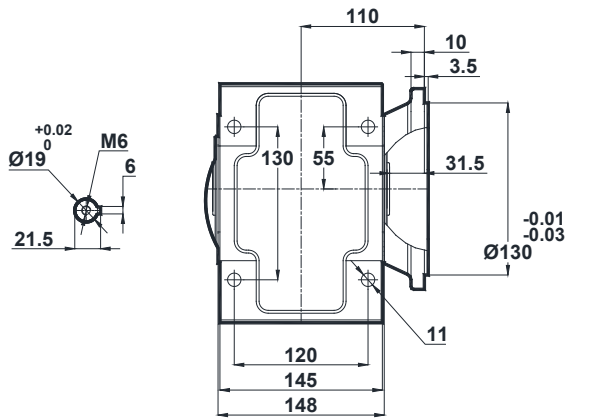
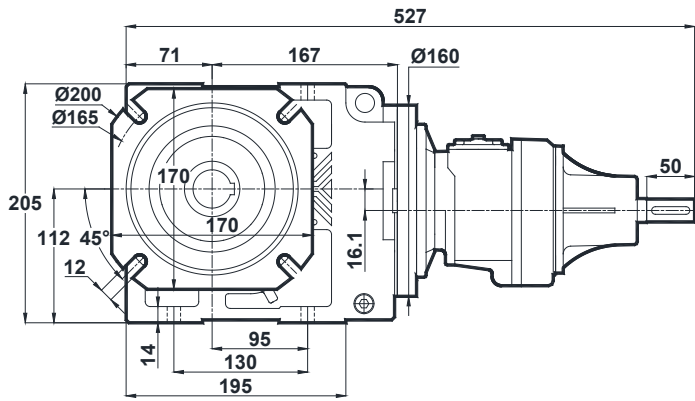

Opsiyonel flanş ölçüleri için sayfa 587'ye bakınız.
Please see on page 587 for optional flange dimensions
Siehe Seite 587 für auswählbare Flanschabmessungen

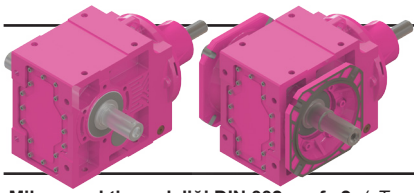

Ölçü Sayfaları Dimension Pages Abmessungsseiten

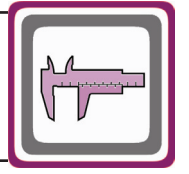

-Mil ucu çektirme deliği DIN 332 sayfa 2 / Tapped center hole to DIN 332, sheet 2 / Zentrierung mit Gewinde DIN 332, Blatt 2

KT275.04
KT276.04

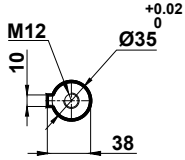
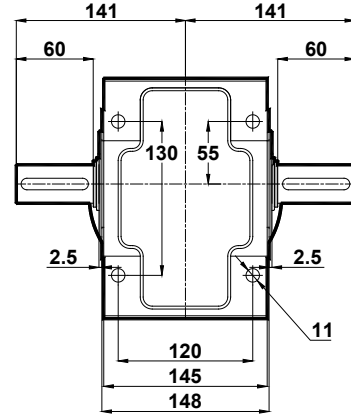
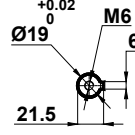
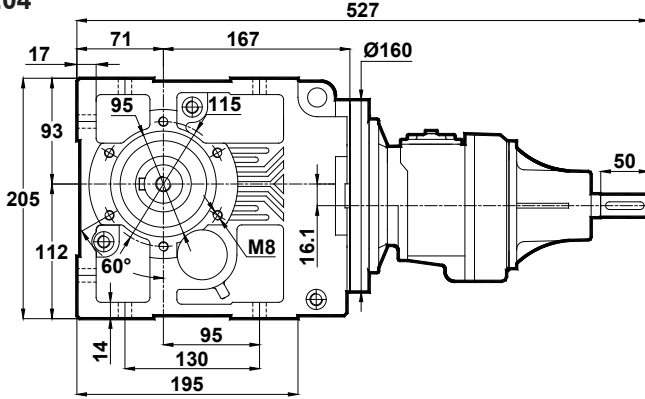

KT275.05
KT276.05

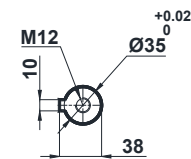
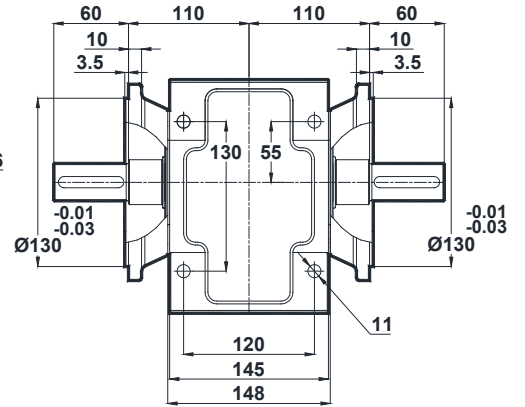
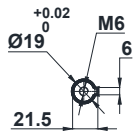
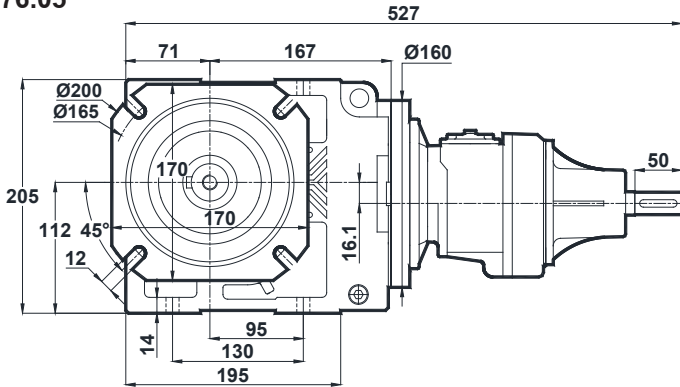

Opsiyonel flanş ölçüleri için sayfa 587'ye bakınız.
Please see on page 587 for optional flange dimensions
Siehe Seite 587 für auswählbare Flanschabmessungen

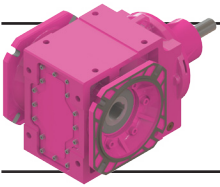

Ölçü Sayfaları

Dimension Pages

Abmessungsseiten

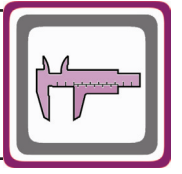

-Mil ucu çekirme deliği DIN 332 sayfa 2 / Tapped center hole to DIN 332, sheet 2 / Zentrierung mit Gewinde DIN 332, Blatt 2

KT275.08
KT276.08

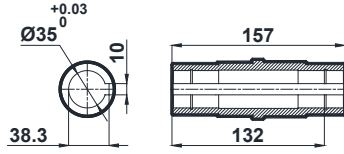
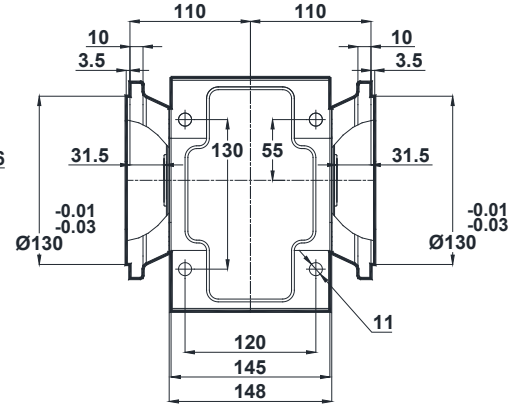
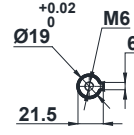
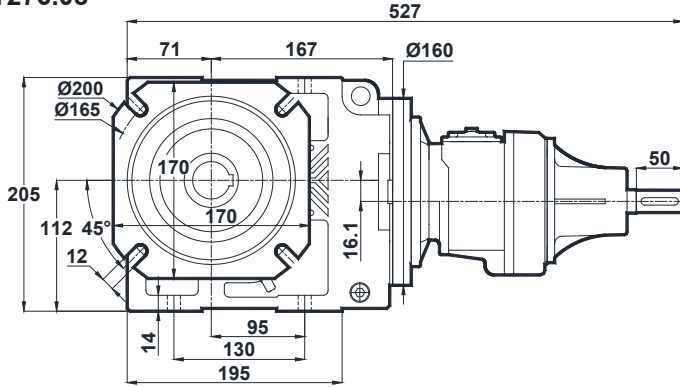

Opsiyonel flanş ölçüleri için sayfa 587'ye bakınız.
Please see on page 587 for optional flange dimensions
Siehe Seite 587 für auswählbare Flanschabmessungen



Ölçü Sayfaları

Dimension Pages

Abmessungenseiten

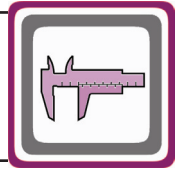

-Mil ucu çektirme deliği DIN 332 sayfa 2 / Tapped center hole to DIN 332, sheet 2 / Zentrierung mit Gewinde DIN 332, Blatt 2

KT283.00

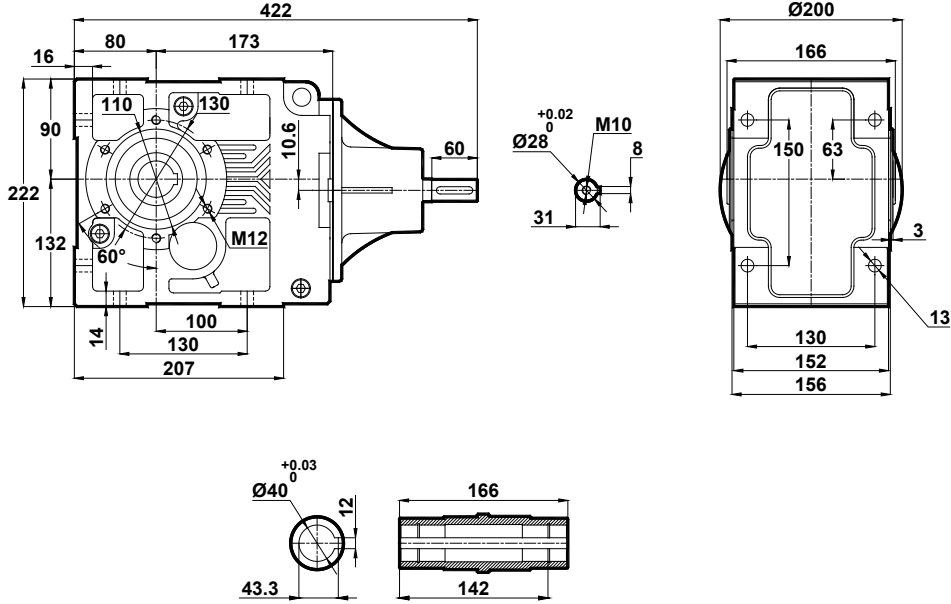

KT283.01

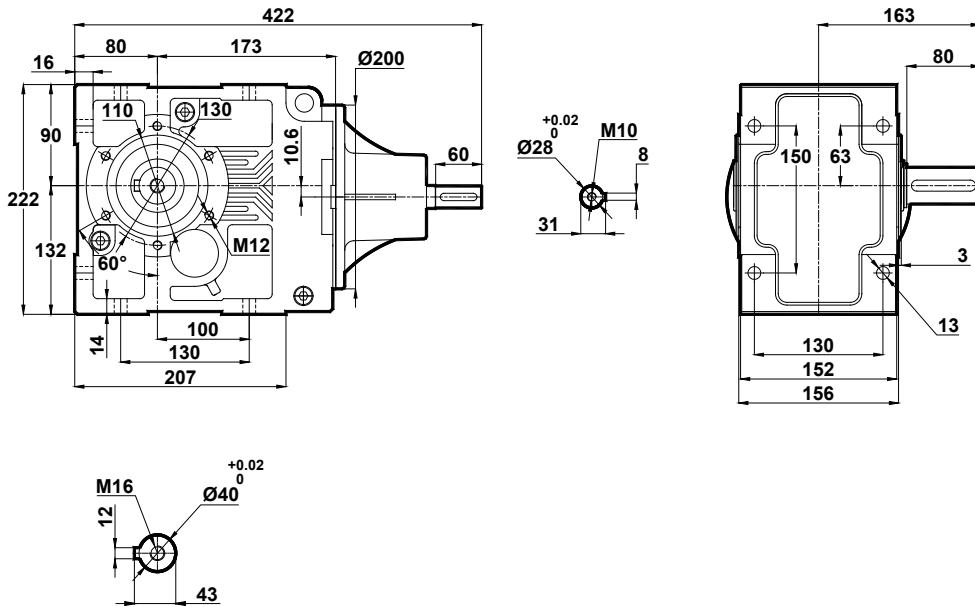



Ölçü Sayfaları

Dimension Pages

Abmessungenseiten



-Mil ucu çekirme deliği DIN 332 sayfa 2 / Tapped center hole to DIN 332, sheet 2 / Zentrierung mit Gewinde DIN 332, Blatt 2

KT283.02

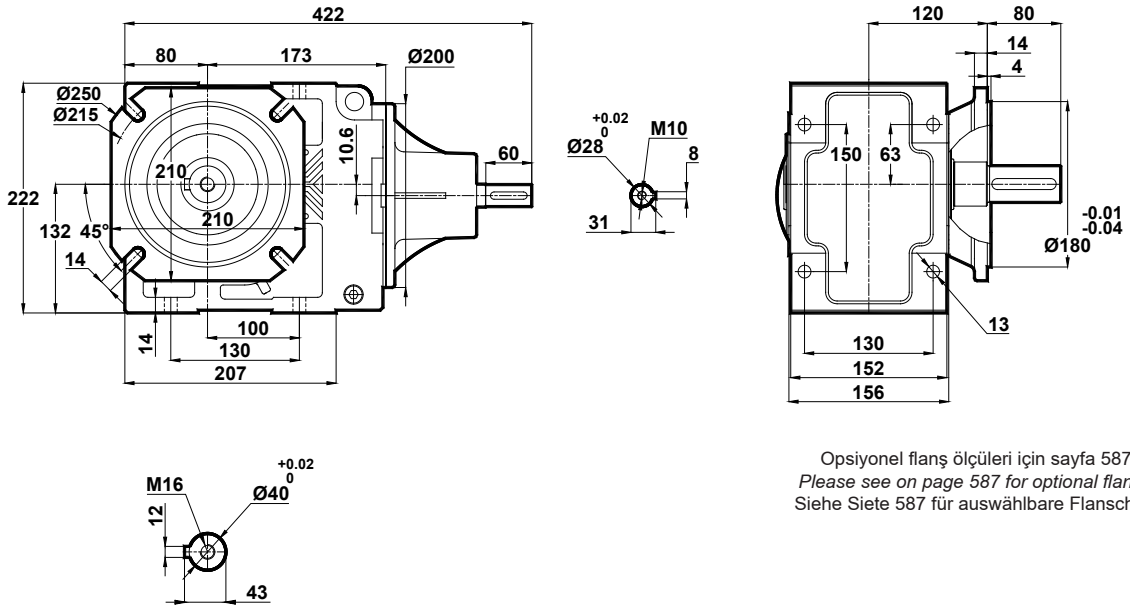

KT283.03

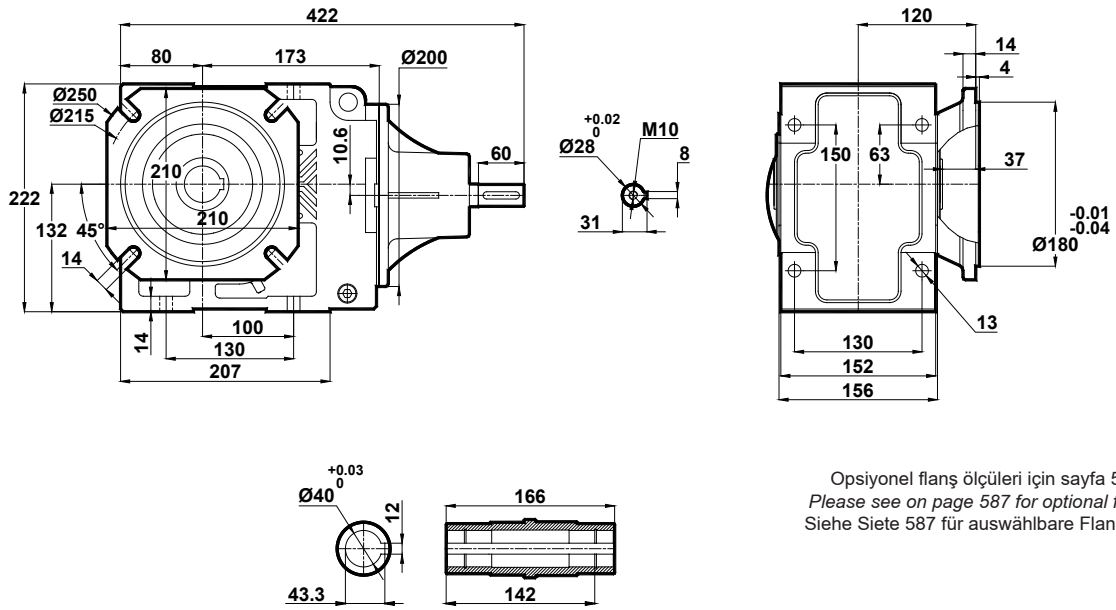

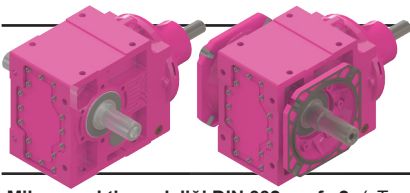

Ölçü Sayfaları

Dimension Pages

Abmessungsseiten

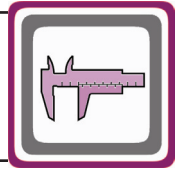

-Mil ucu çekirme deliği DIN 332 sayfa 2 / Tapped center hole to DIN 332, sheet 2 / Zentrierung mit Gewinde DIN 332, Blatt 2

KT283.04

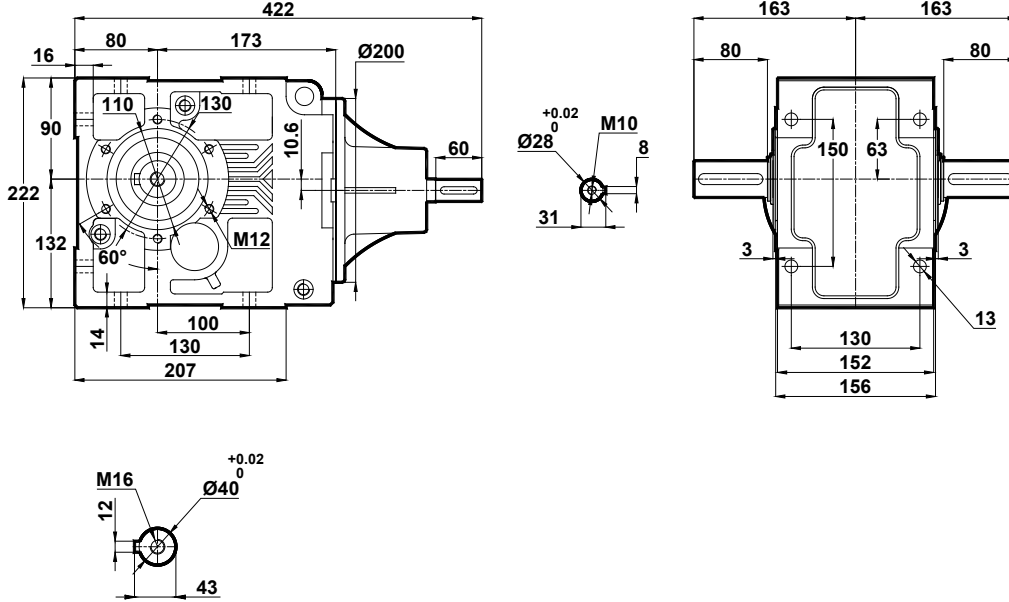

KT283.05

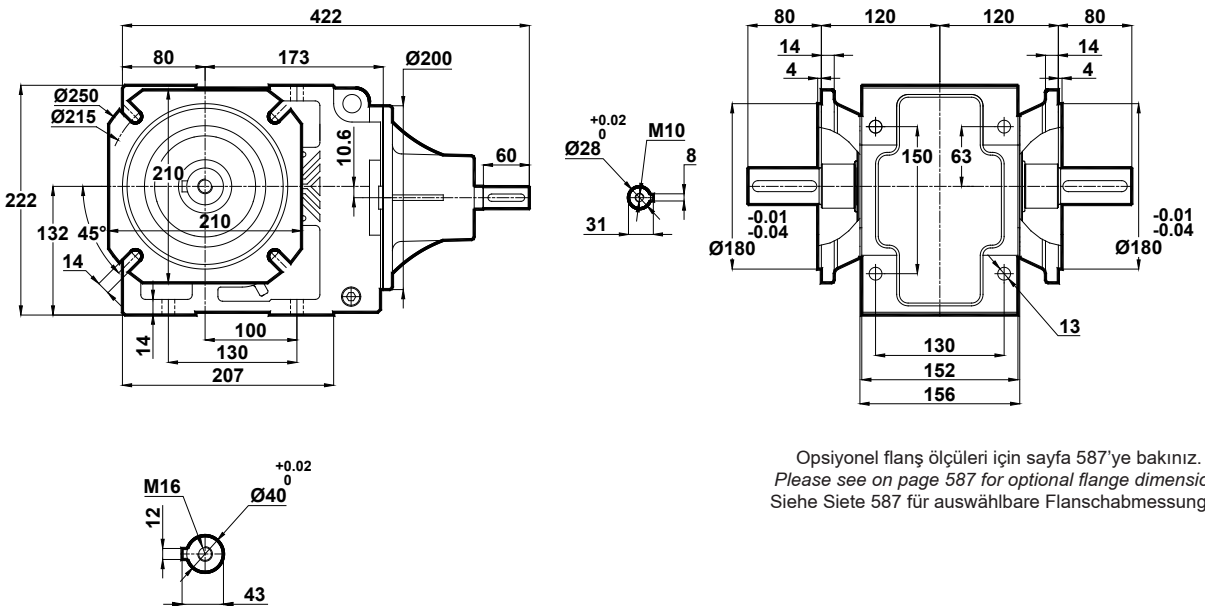

Opsiyonel flanş ölçüleri için sayfa 587'ye bakınız.
Please see on page 587 for optional flange dimensions
Siehe Siete 587 für auswählbare Flanschabmessungen



Ölçü Sayfaları

Dimension Pages

Abmessungsseiten



-Mil ucu çektirme deliği DIN 332 sayfa 2 / Tapped center hole to DIN 332, sheet 2 / Zentrierung mit Gewinde DIN 332, Blatt 2

KT283.08

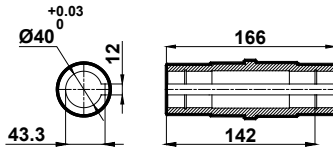
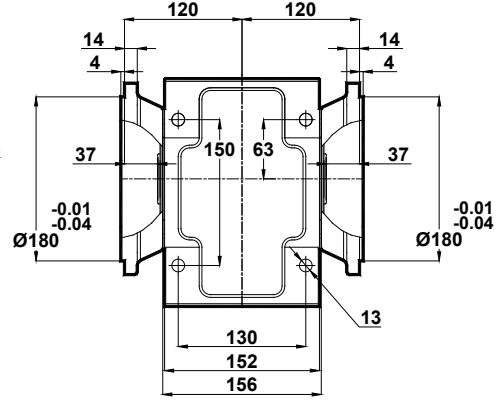
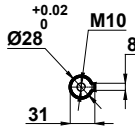
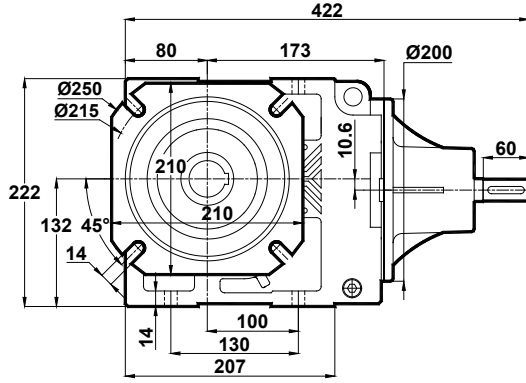

Opsiyonel flanş ölçüleri için sayfa 587'ye bakınız.
Please see on page 587 for optional flange dimensions
Siehe Seite 587 für auswählbare Flanschabmessungen

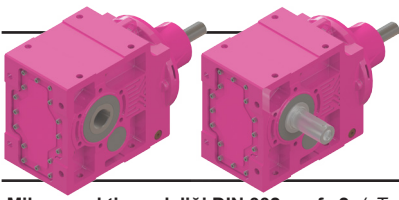

Ölçü Sayfaları

Dimension Pages

Abmessungsseiten

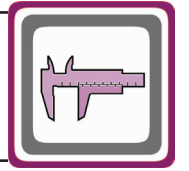

-Mil ucu çekirme deliği DIN 332 sayfa 2 / Tapped center hole to DIN 332, sheet 2 / Zentrierung mit Gewinde DIN 332, Blatt 2

KT284.00

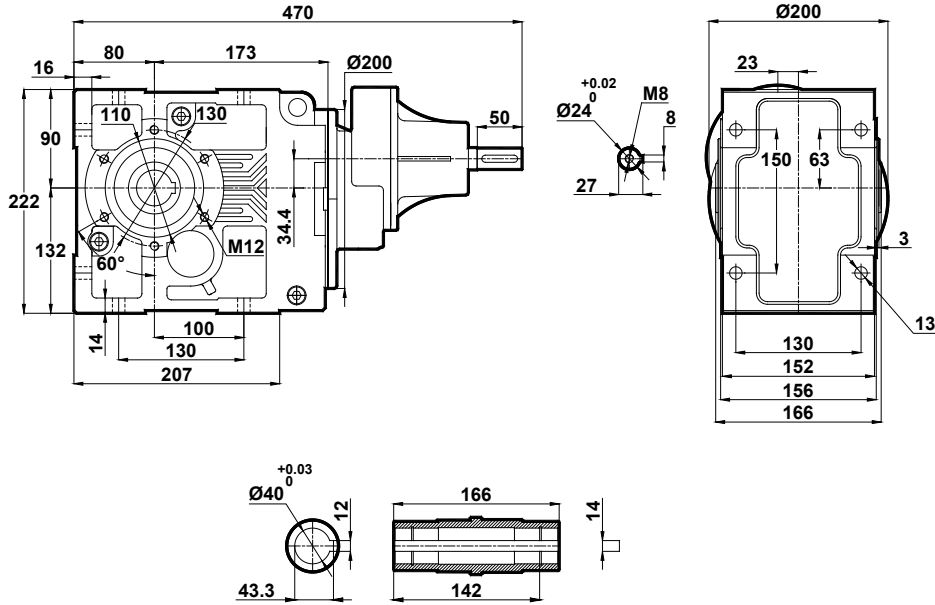

KT284.01

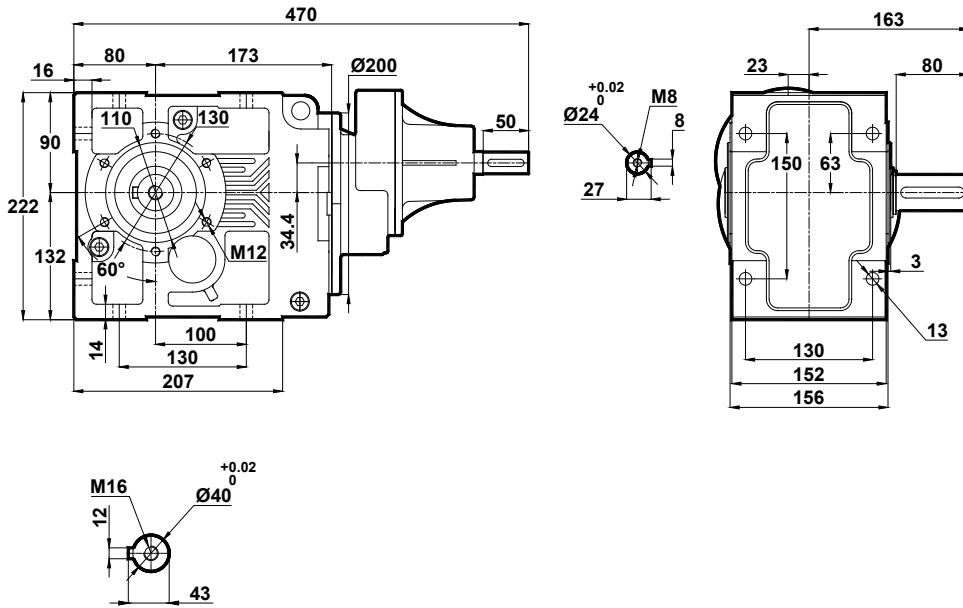



Ölçü Sayfaları

Dimension Pages

Abmessungsseiten



-Mil ucu çekirme deliği DIN 332 sayfa 2 / Tapped center hole to DIN 332, sheet 2 / Zentrierung mit Gewinde DIN 332, Blatt 2

KT284.02

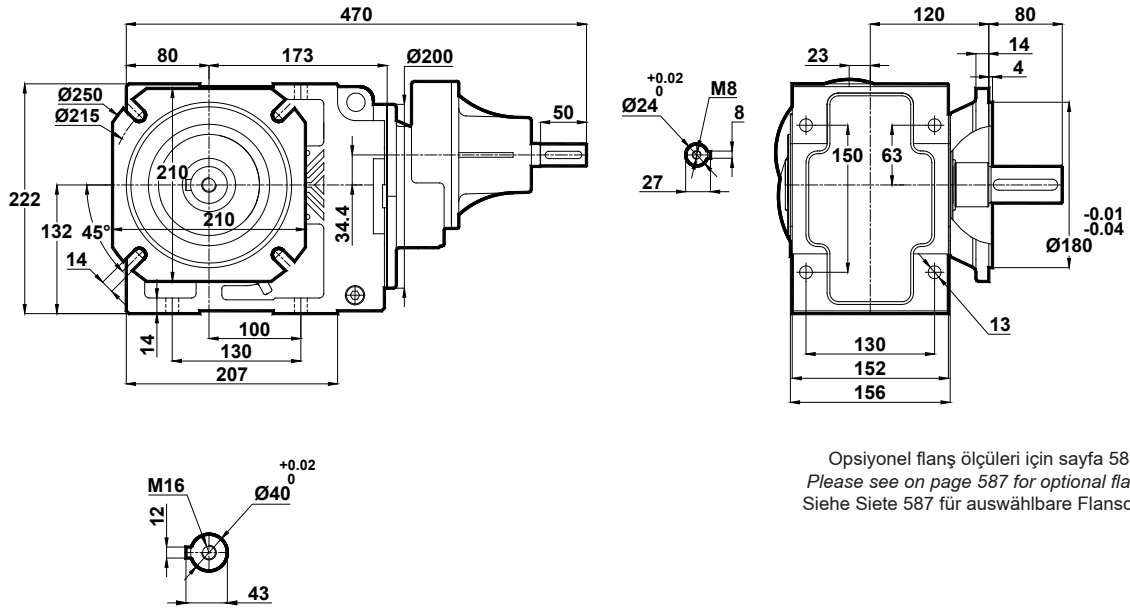

Opsiyonel flanş ölçüleri için sayfa 587'ye bakınız.
Please see on page 587 for optional flange dimensions
Siehe Seite 587 für auswählbare Flanschabmessungen

KT284.03

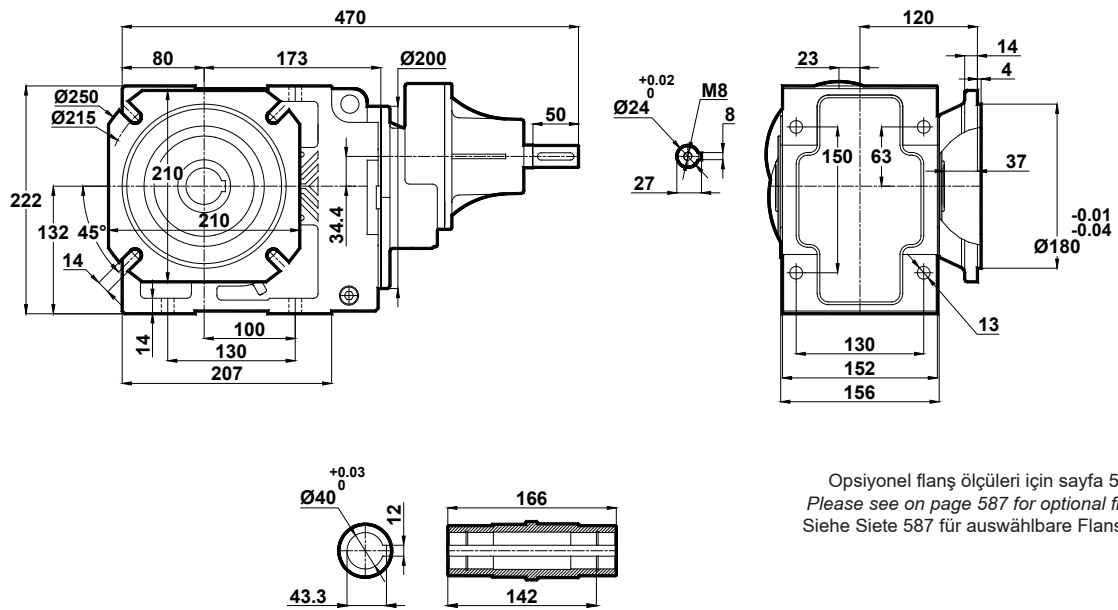

Opsiyonel flanş ölçüleri için sayfa 587'ye bakınız.
Please see on page 587 for optional flange dimensions
Siehe Seite 587 für auswählbare Flanschabmessungen

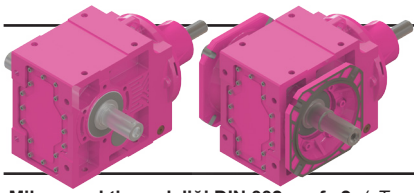

Ölçü Sayfaları Dimension Pages Abmessungsseiten

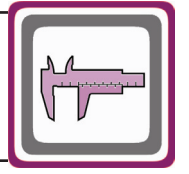

-Mil ucu çekirme deliği DIN 332 sayfa 2 / Tapped center hole to DIN 332, sheet 2 / Zentrierung mit Gewinde DIN 332, Blatt 2

KT284.04

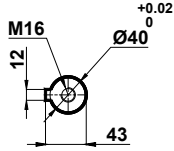
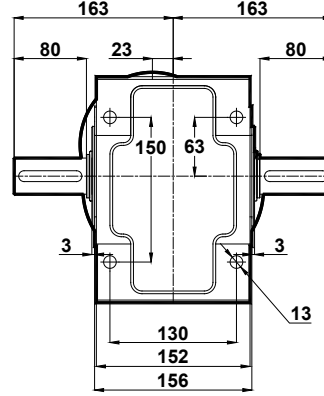
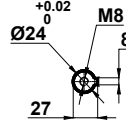
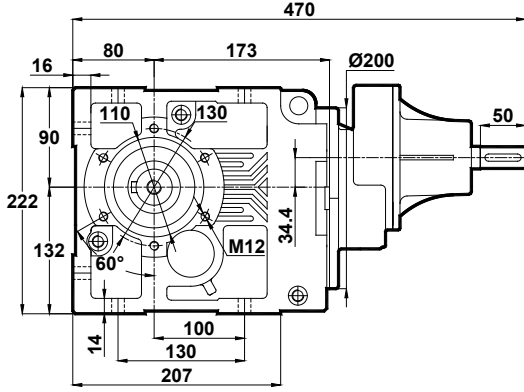

KT284.05

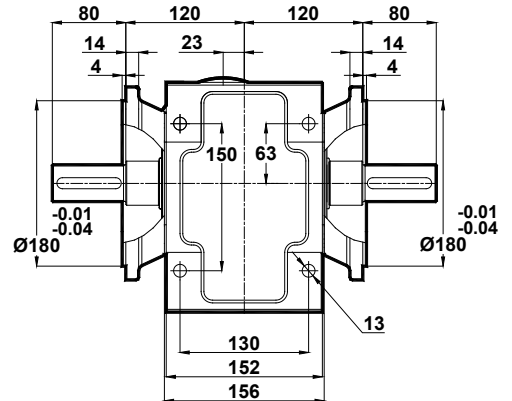
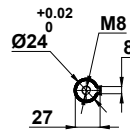
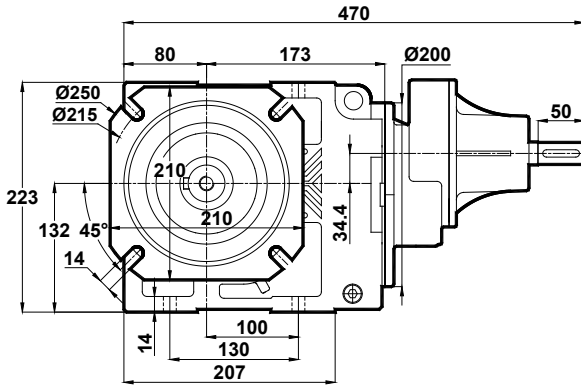

Opsiyonel flanş ölçüleri için sayfa 587'ye bakınız.
Please see on page 587 for optional flange dimensions
Siehe Seite 587 für auswählbare Flanschabmessungen



Ölçü Sayfaları

Dimension Pages

Abmessungsseiten

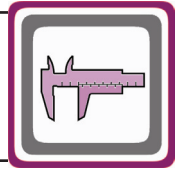

-Mil ucu çektirme deliği DIN 332 sayfa 2 / Tapped center hole to DIN 332, sheet 2 / Zentrierung mit Gewinde DIN 332, Blatt 2

KT285.00
KT286.00

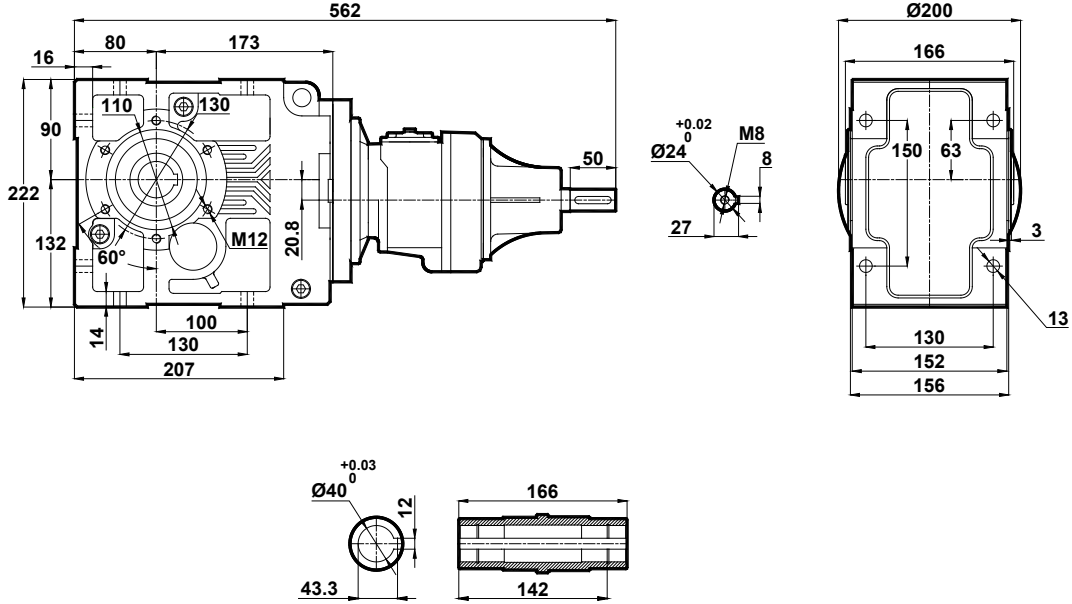

KT285.01
KT286.01

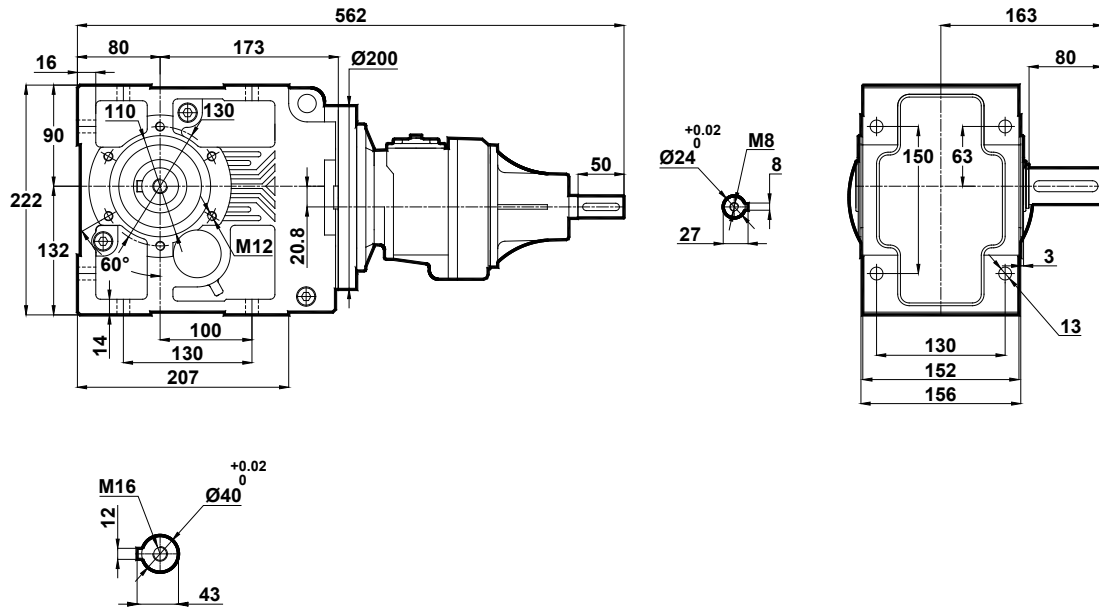



Ölçü Sayfaları

Dimension Pages

Abmessungsseiten



-Mil ucu çektirme deliği DIN 332 sayfa 2 / Tapped center hole to DIN 332, sheet 2 / Zentrierung mit Gewinde DIN 332, Blatt 2

KT285.02
KT286.02

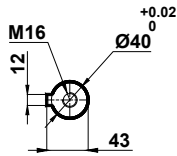
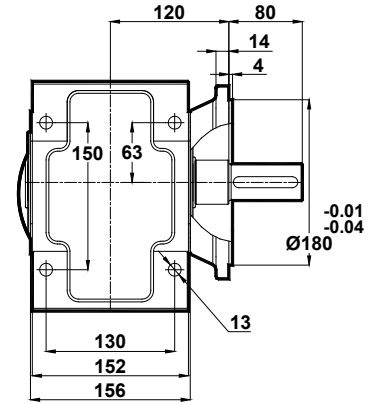
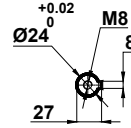
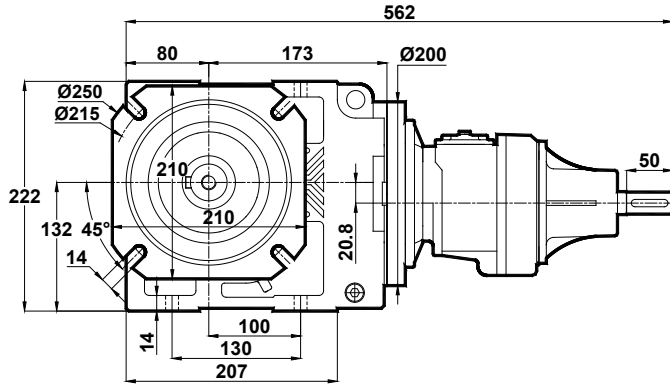

Opsiyonel flanş ölçüleri için sayfa 587'ye bakınız.
Please see on page 587 for optional flange dimensions
Siehe Seite 587 für auswählbare Flanschabmessungen

KT285.03
KT286.03

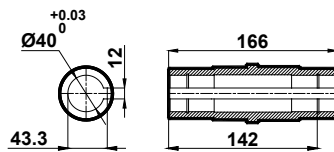
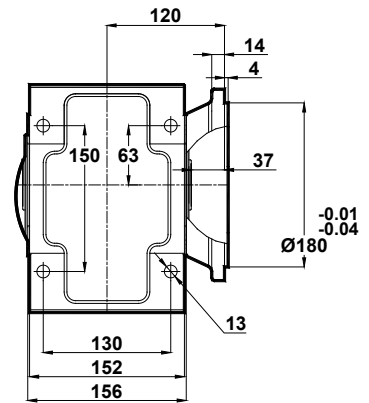
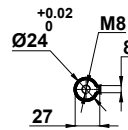
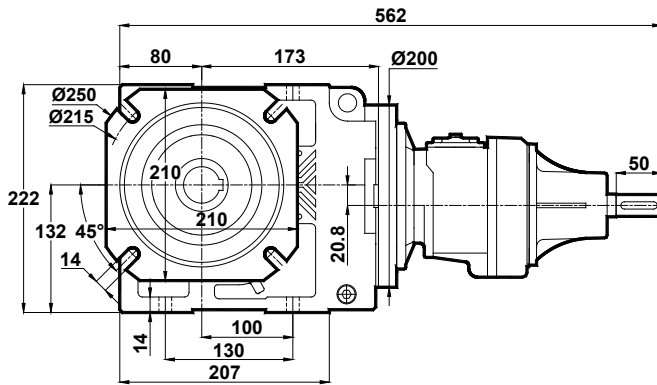

Opsiyonel flanş ölçüleri için sayfa 587'ye bakınız.
Please see on page 587 for optional flange dimensions
Siehe Seite 587 für auswählbare Flanschabmessungen

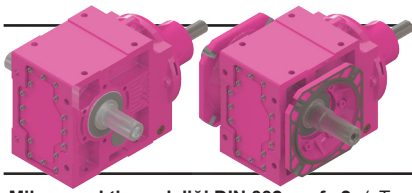

Ölçü Sayfaları

Dimension Pages

Abmessungsseiten

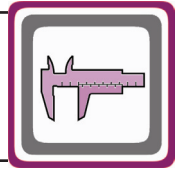

-Mil ucu çektirme deliği DIN 332 sayfa 2 / Tapped center hole to DIN 332, sheet 2 / Zentrierung mit Gewinde DIN 332, Blatt 2

KT285.04
KT286.04

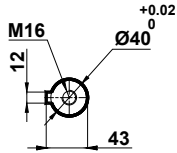
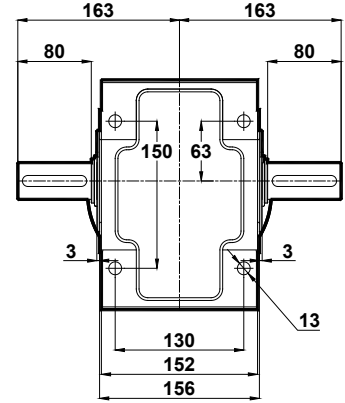
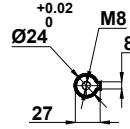
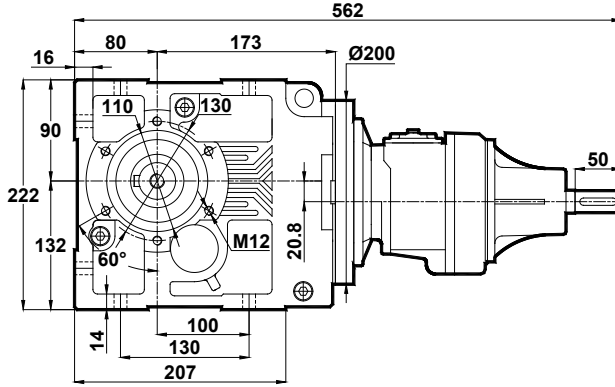

KT285.05
KT286.05

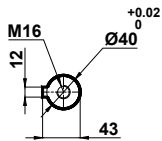
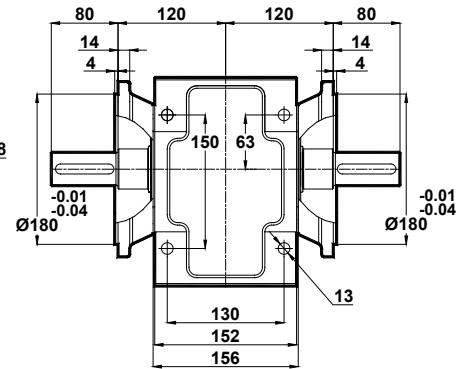
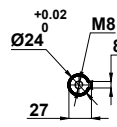
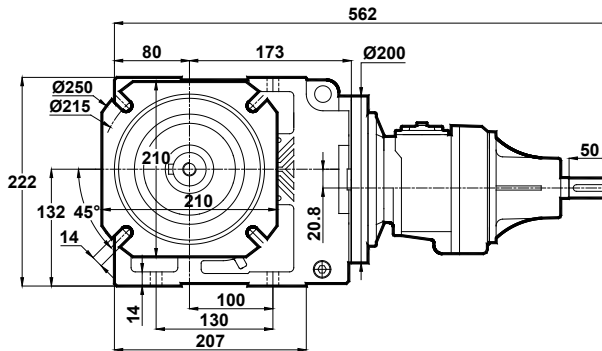

Opsiyonel flanş ölçüleri için sayfa 587'ye bakınız.
Please see on page 587 for optional flange dimensions
Siehe Seite 587 für auswählbare Flanschabmessungen



Ölçü Sayfaları Dimension Pages Abmessungsseiten



-Mil ucu çektirme deliği DIN 332 sayfa 2 / Tapped center hole to DIN 332, sheet 2 / Zentrierung mit Gewinde DIN 332, Blatt 2

KT285.08
KT286.08

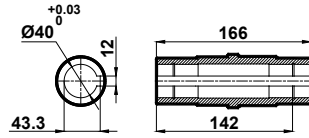
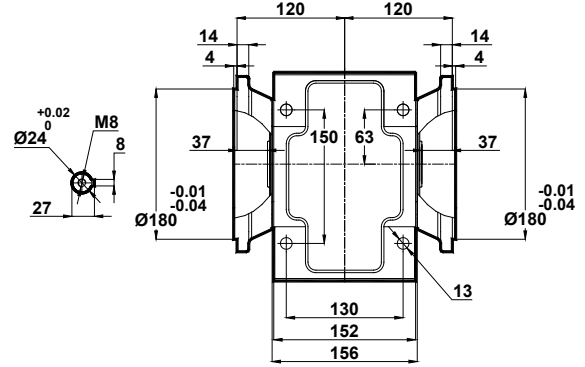
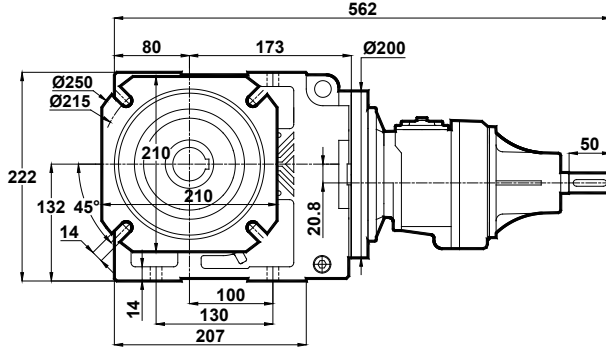

Opsiyonel flanş ölçüleri için sayfa 587'ye bakınız.
Please see on page 587 for optional flange dimensions
Siehe Seite 587 für auswählbare Flanschabmessungen



Ölçü Sayfaları

Dimension Pages

Abmessungsseiten

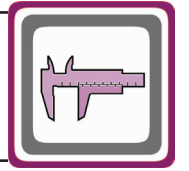

-Mil ucu çektirme deliği DIN 332 sayfa 2 / Tapped center hole to DIN 332, sheet 2 / Zentrierung mit Gewinde DIN 332, Blatt 2

KT373.00

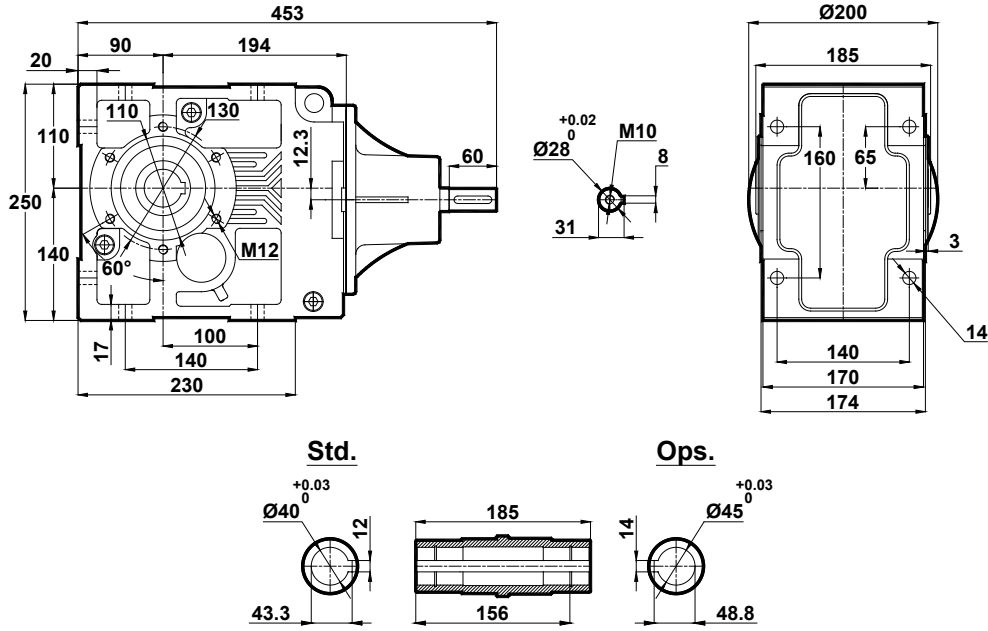

KT373.01

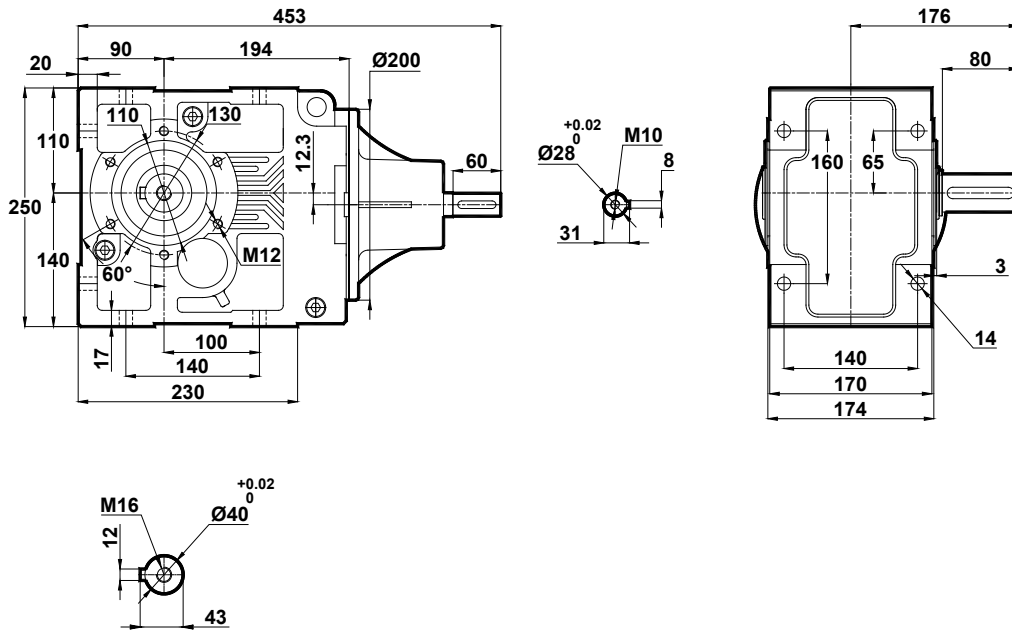



Ölçü Sayfaları Dimension Pages Abmessungenseiten



-Mil ucu çekirme deliği DIN 332 sayfa 2 / Tapped center hole to DIN 332, sheet 2 / Zentrierung mit Gewinde DIN 332, Blatt 2

KT373.02

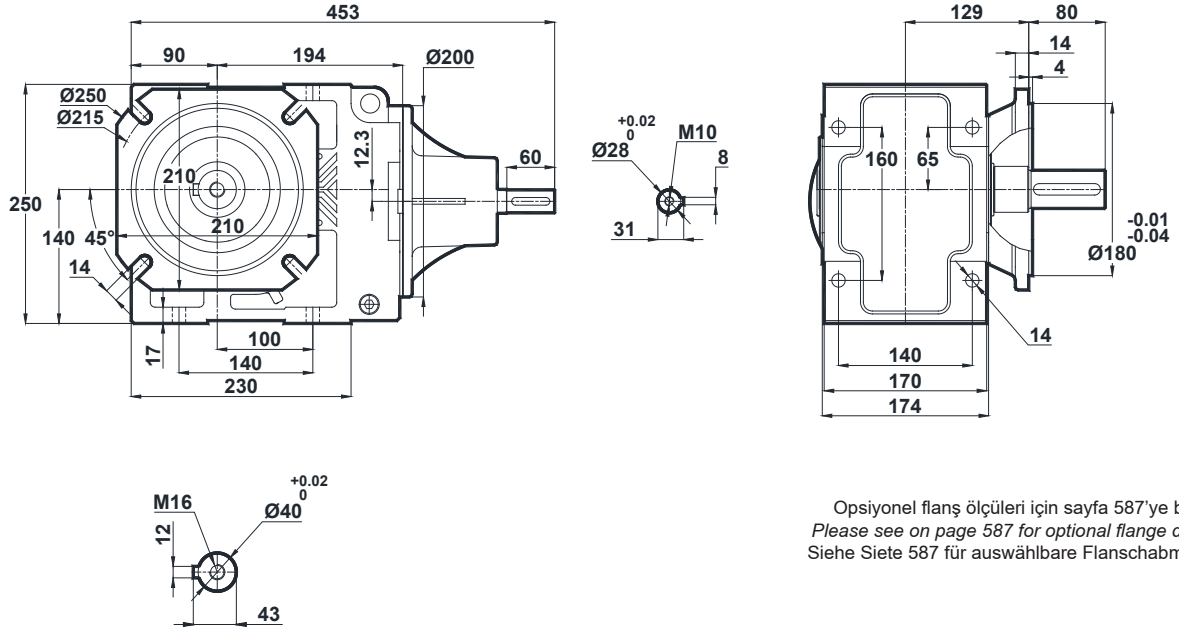

KT373.03

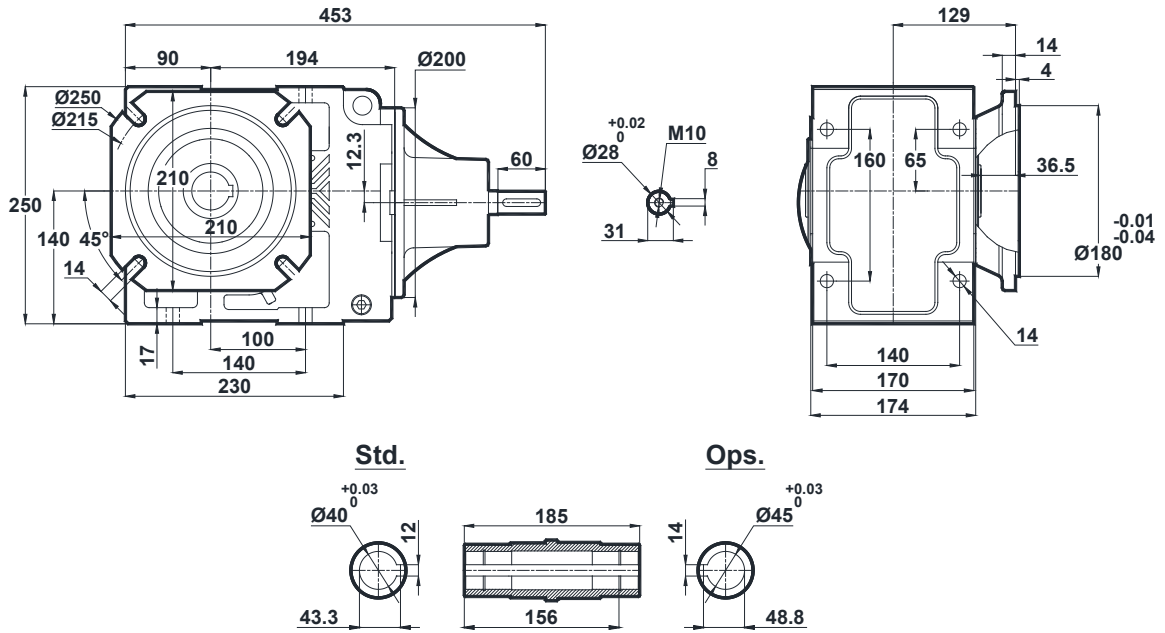

Std.



Ops.

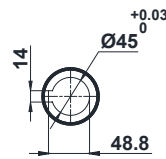

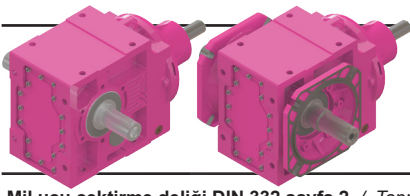

Ölçü Sayfaları Dimension Pages Abmessungenseiten

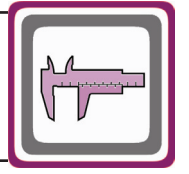

-Mil ucu çektirme deliği DIN 332 sayfa 2 / Tapped center hole to DIN 332, sheet 2 / Zentrierung mit Gewinde DIN 332, Blatt 2

KT373.04

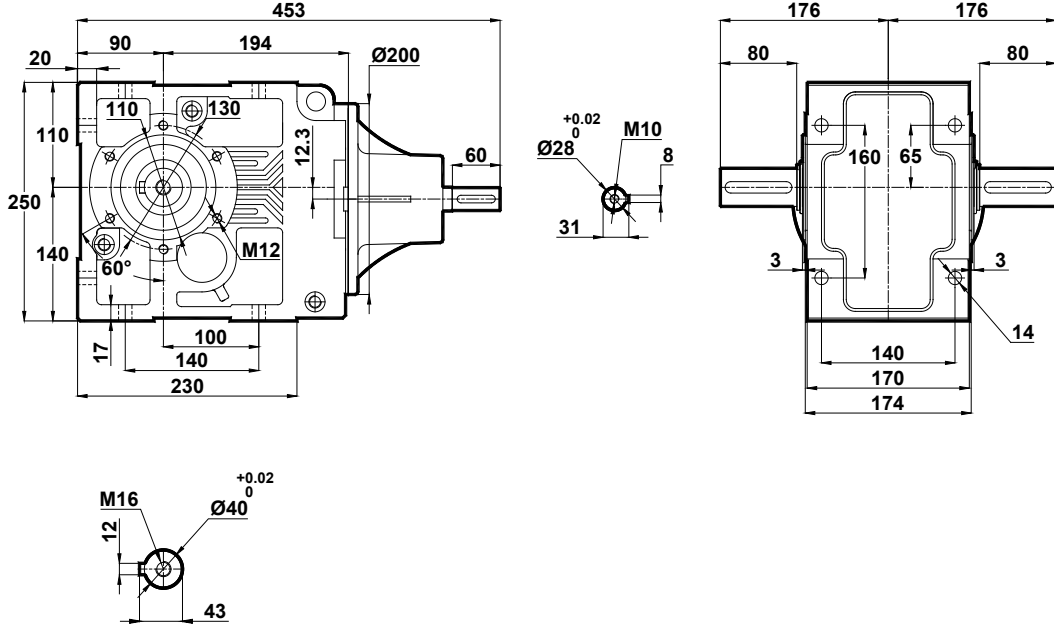

KT373.05

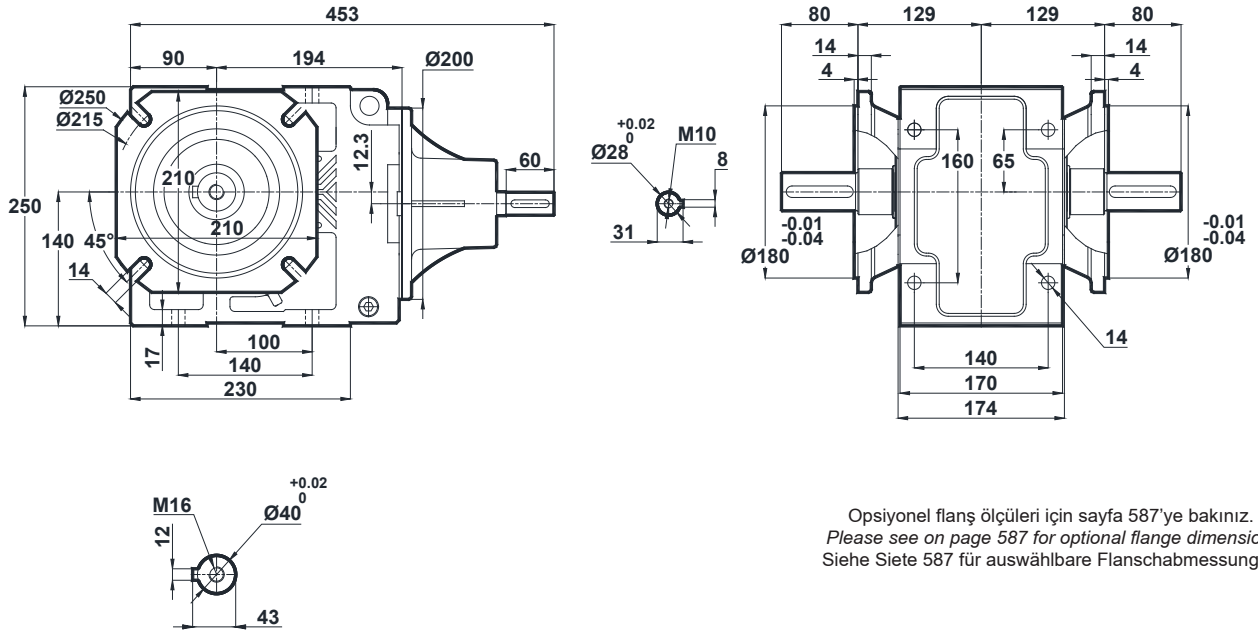

Opsiyonel flanş ölçüleri için sayfa 587'ye bakınız.
Please see on page 587 for optional flange dimensions
Siehe Seite 587 für auswählbare Flanschabmessungen

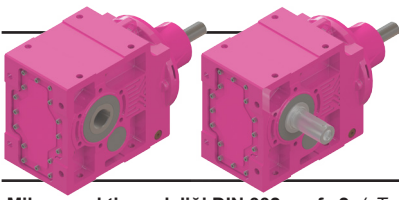

Ölçü Sayfaları

Dimension Pages

Abmessungsseiten

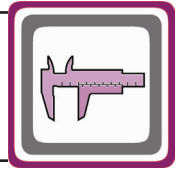

-Mil ucu çekirme deliği DIN 332 sayfa 2 / Tapped center hole to DIN 332, sheet 2 / Zentrierung mit Gewinde DIN 332, Blatt 2

KT374.00

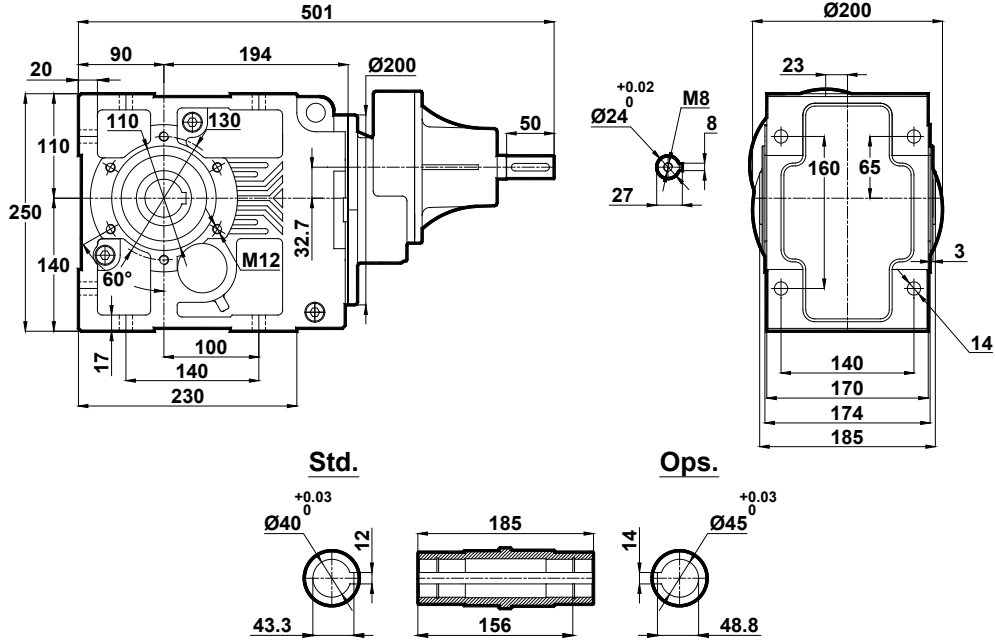

KT374.01

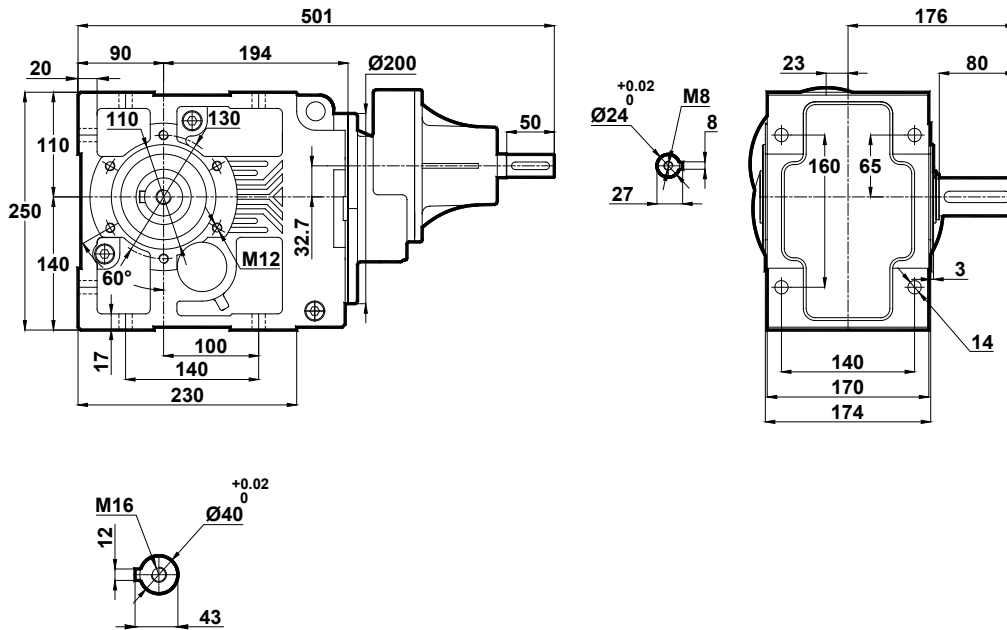



Ölçü Sayfaları

Dimension Pages

Abmessungsseiten



-Mil ucu çektirme deliği DIN 332 sayfa 2 / Tapped center hole to DIN 332, sheet 2 / Zentrierung mit Gewinde DIN 332, Blatt 2

KT374.02

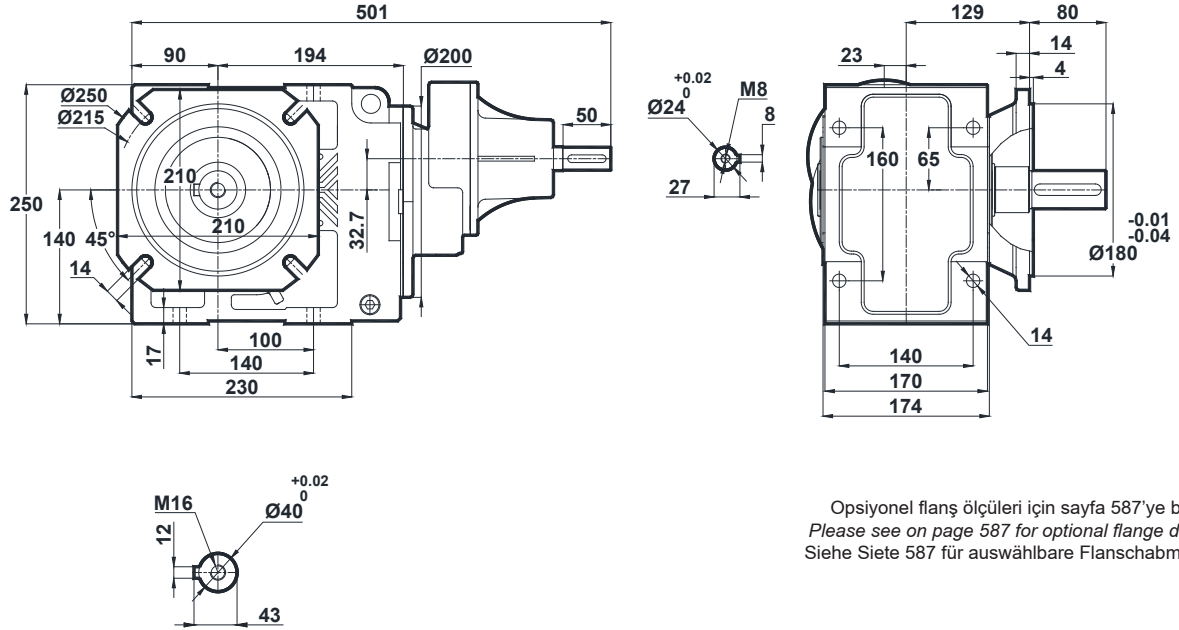

Opsiyonel flanş ölçüleri için sayfa 587'ye bakınız.
Please see on page 587 for optional flange dimensions
Siehe Seite 587 für auswählbare Flanschabmessungen

KT374.03

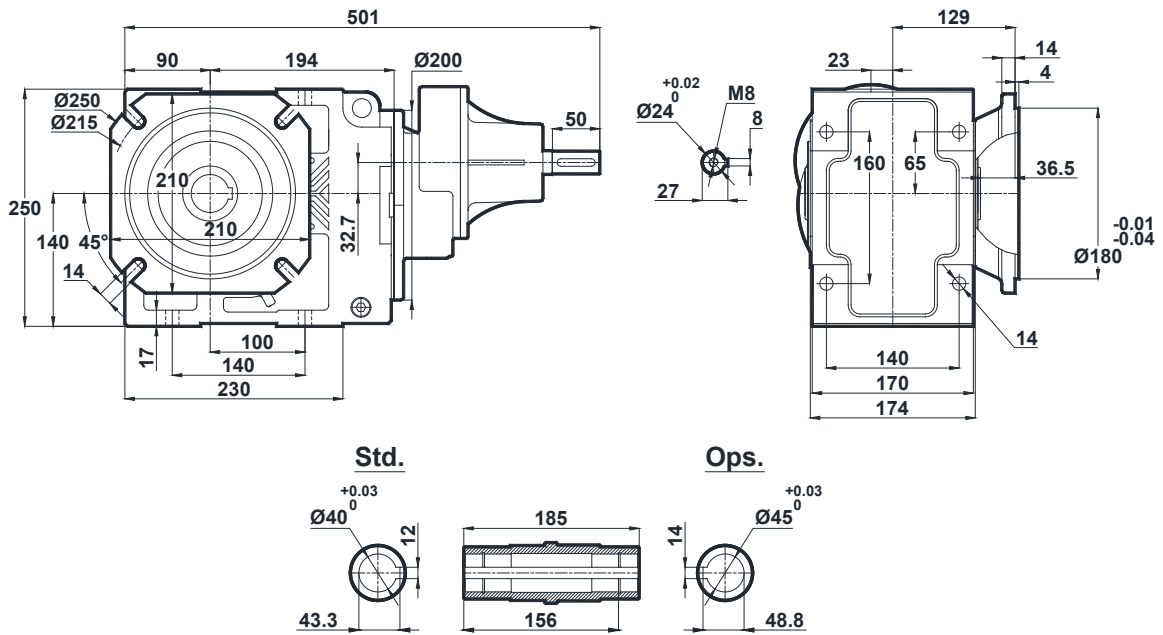

Opsiyonel flanş ölçüleri için sayfa 587'ye bakınız.
Please see on page 587 for optional flange dimensions
Siehe Seite 587 für auswählbare Flanschabmessungen

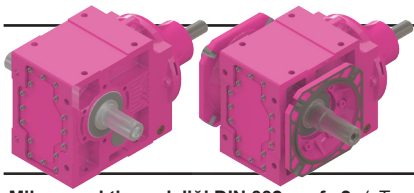

Ölçü Sayfaları Dimension Pages Abmessungsseiten

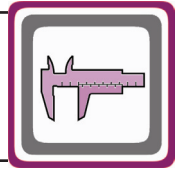

-Mil ucu çekirme deliği DIN 332 sayfa 2 / Tapped center hole to DIN 332, sheet 2 / Zentrierung mit Gewinde DIN 332, Blatt 2

KT374.04

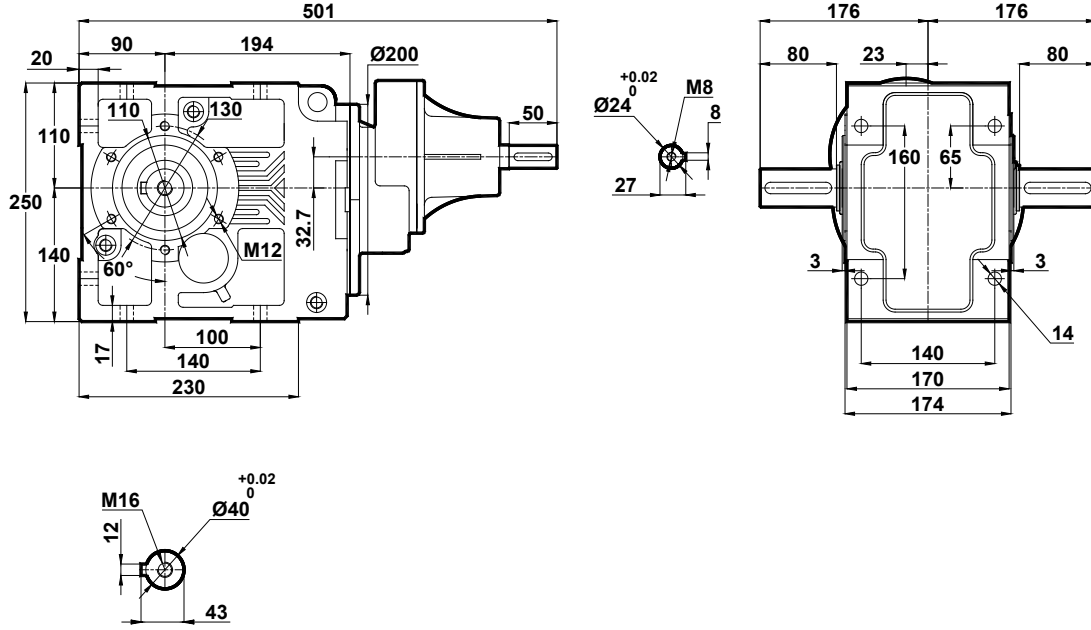

KT374.05

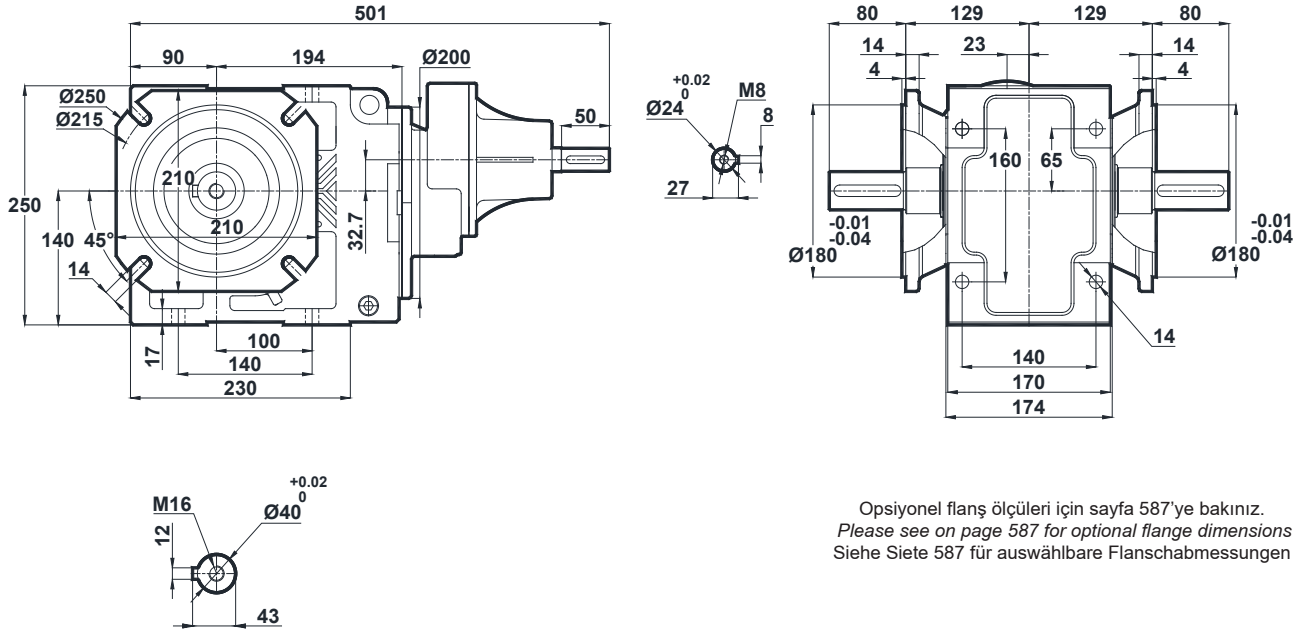

Opsiyonel flanş ölçüleri için sayfa 587'ye bakınız.
Please see on page 587 for optional flange dimensions
Siehe Seite 587 für auswählbare Flanschabmessungen



Ölçü Sayfaları

Dimension Pages

Abmessungsseiten

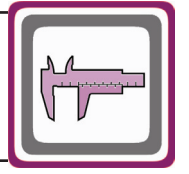

-Mil ucu çekirme deliği DIN 332 sayfa 2 / Tapped center hole to DIN 332, sheet 2 / Zentrierung mit Gewinde DIN 332, Blatt 2

KT375.00
KT376.00

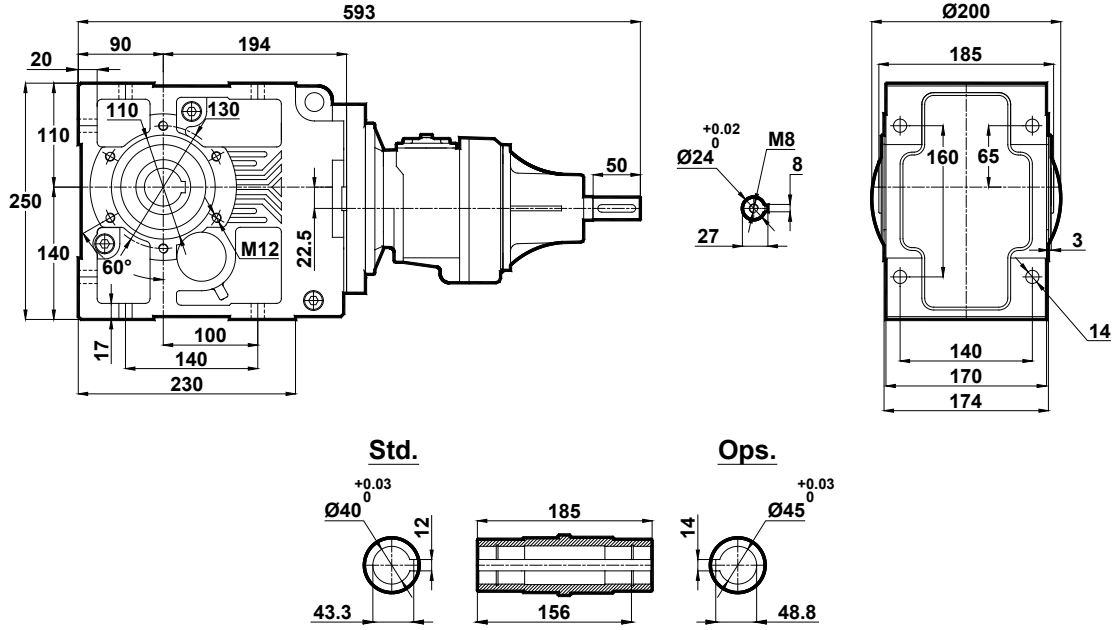

KT375.01
KT376.01

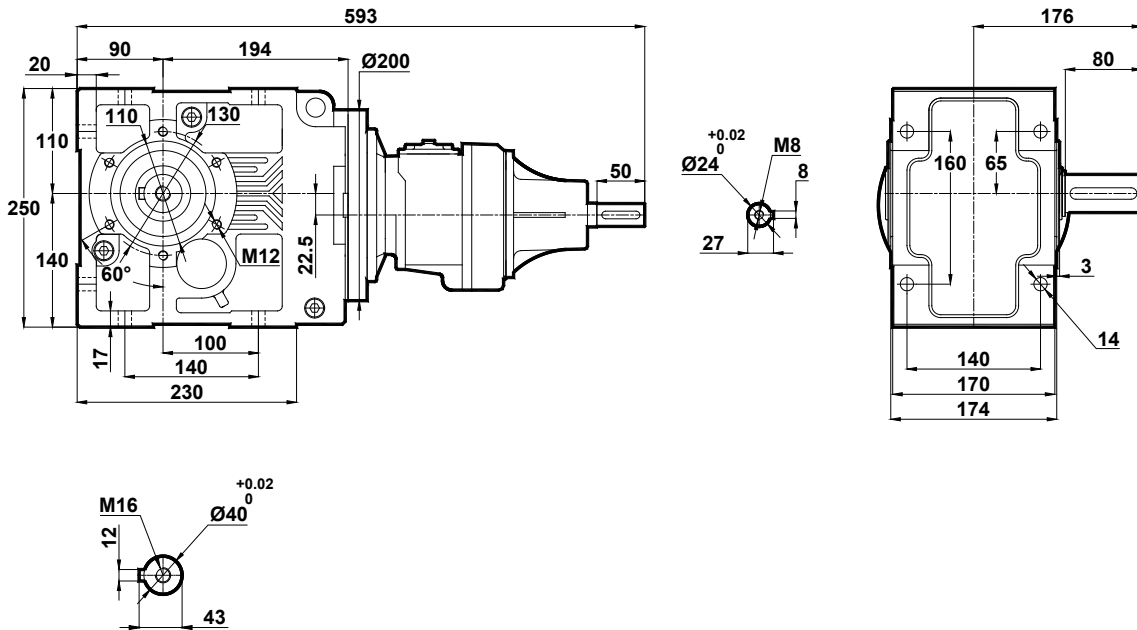



Ölçü Sayfaları Dimension Pages Abmessungenseiten



-Mil ucu çektirme deliği DIN 332 sayfa 2 / Tapped center hole to DIN 332, sheet 2 / Zentrierung mit Gewinde DIN 332, Blatt 2

KT375.02
KT376.02

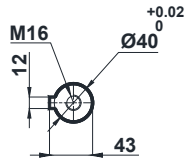
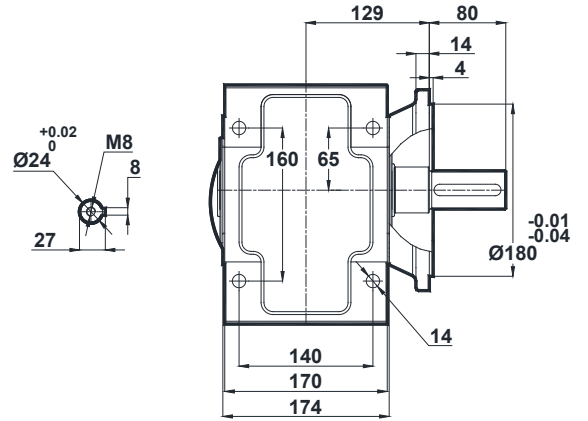
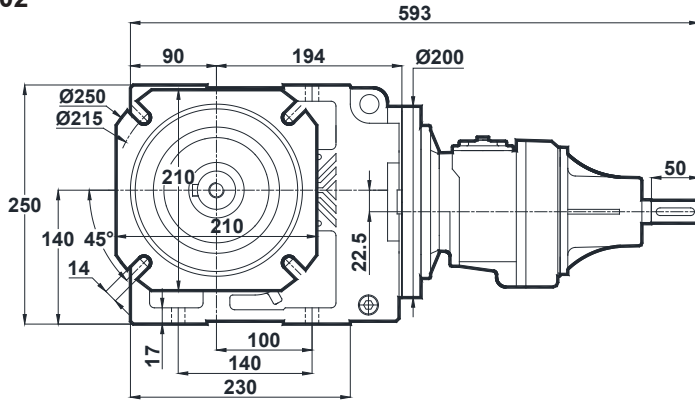

Opsiyonel flanş ölçüleri için sayfa 587'ye bakınız.
Please see on page 587 for optional flange dimensions
Siehe Seite 587 für auswählbare Flanschabmessungen

KT375.03
KT376.03

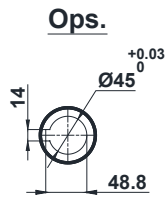
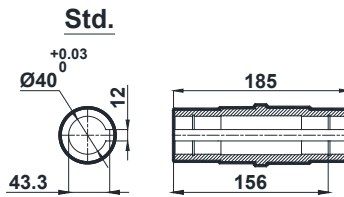
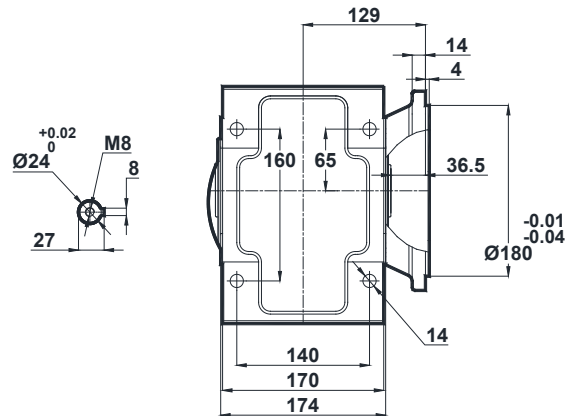
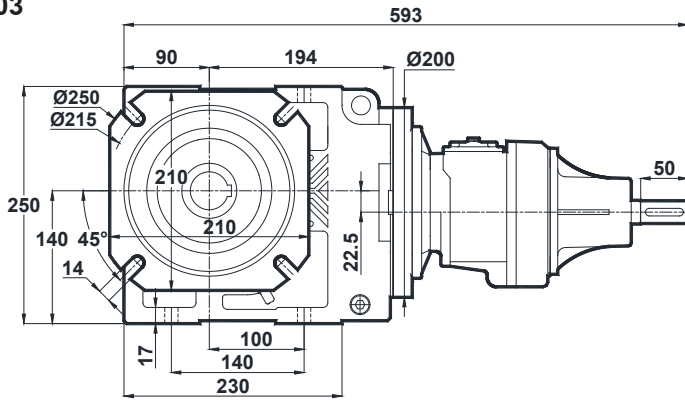

Opsiyonel flanş ölçüleri için sayfa 587'ye bakınız.
Please see on page 587 for optional flange dimensions
Siehe Seite 587 für auswählbare Flanschabmessungen

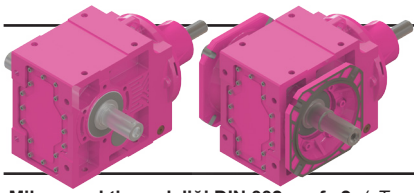

Ölçü Sayfaları Dimension Pages Abmessungsseiten

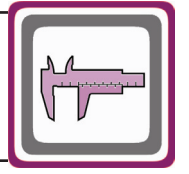

-Mil ucu çekirme deliği DIN 332 sayfa 2 / Tapped center hole to DIN 332, sheet 2 / Zentrierung mit Gewinde DIN 332, Blatt 2

KT375.04
KT376.04

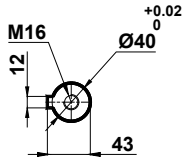
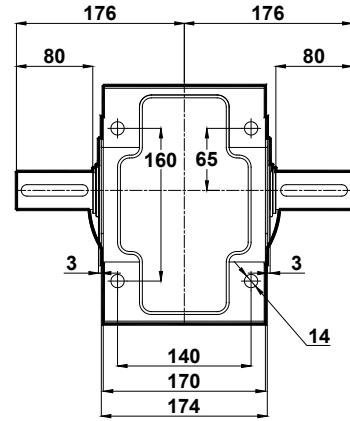
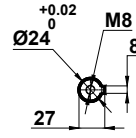
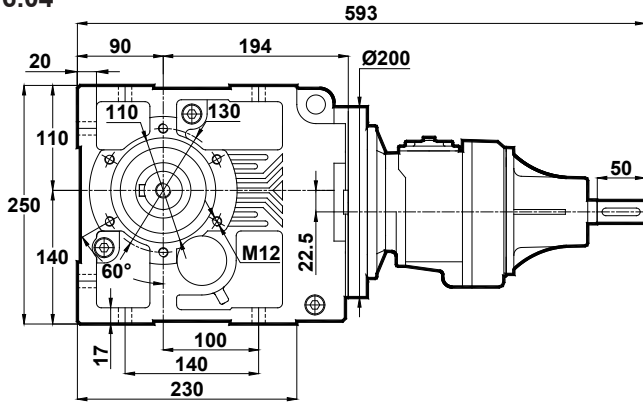

KT375.05
KT376.05

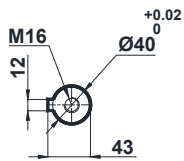
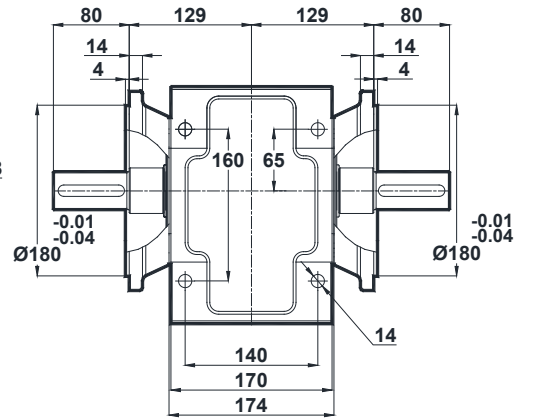
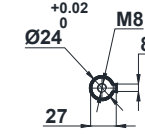
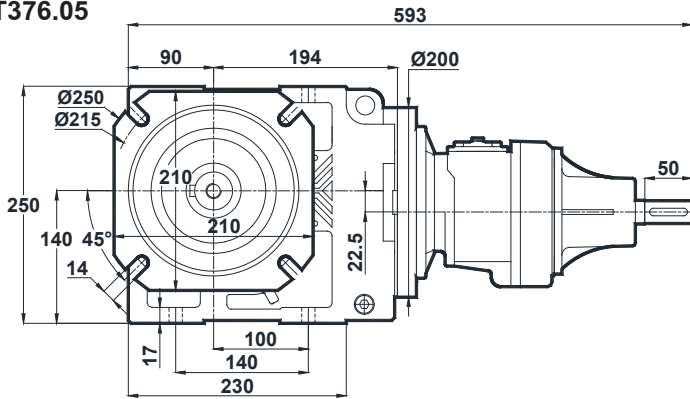

Opsiyonel flanş ölçüleri için sayfa 587'ye bakınız.
Please see on page 587 for optional flange dimensions
Siehe Seite 587 für auswählbare Flanschabmessungen



Ölçü Sayfaları

Dimension Pages

Abmessungenseiten

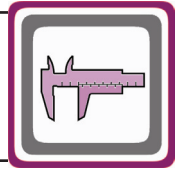

-Mil ucu çekirme deliği DIN 332 sayfa 2 / Tapped center hole to DIN 332, sheet 2 / Zentrierung mit Gewinde DIN 332, Blatt 2

KT473.00

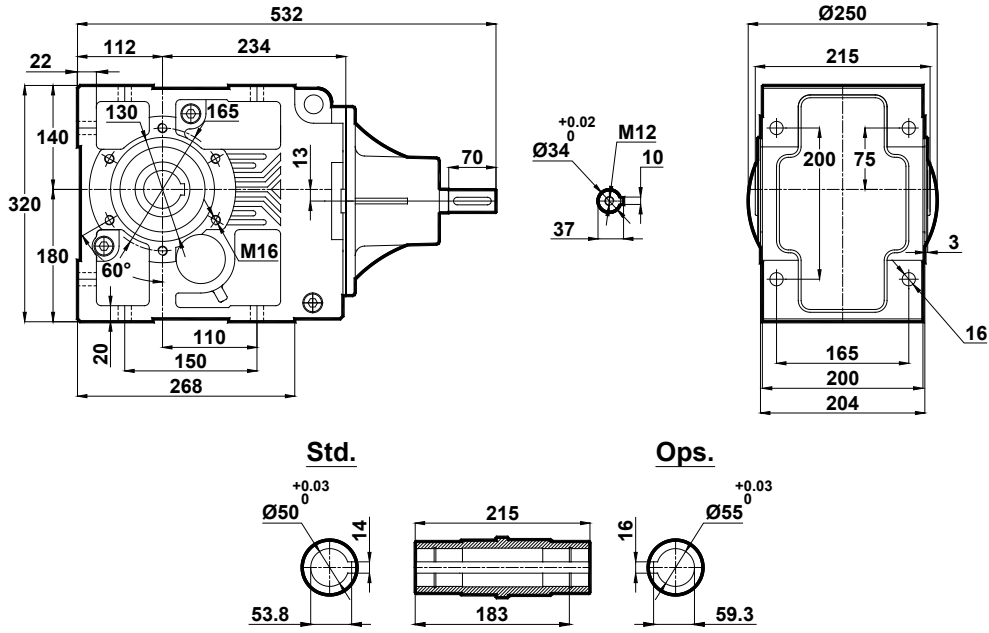

KT473.01

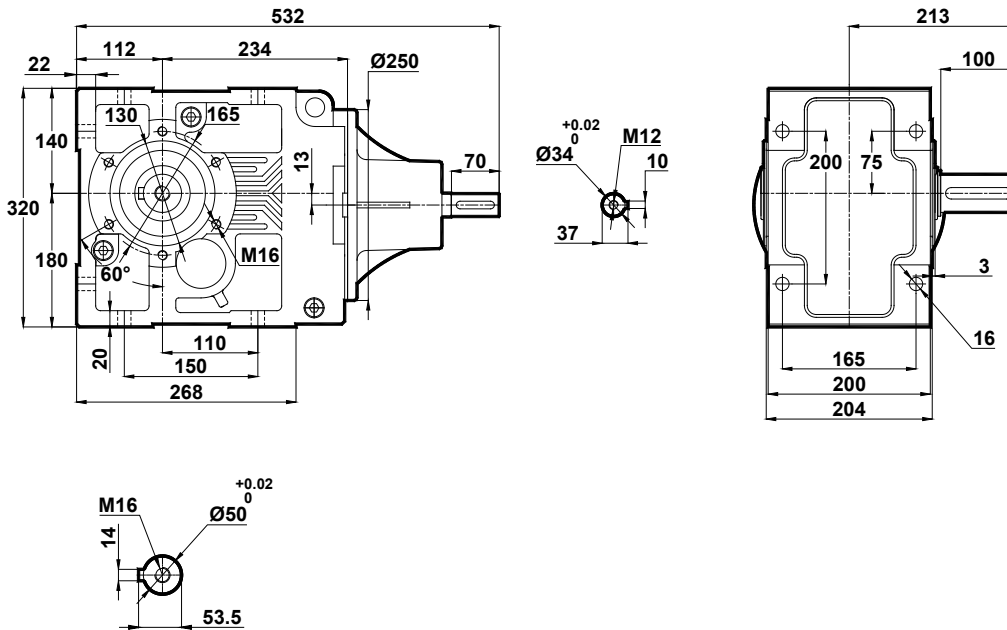



Ölçü Sayfaları Dimension Pages Abmessungenseiten



-Mil ucu çekirme deliği DIN 332 sayfa 2 / Tapped center hole to DIN 332, sheet 2 / Zentrierung mit Gewinde DIN 332, Blatt 2

KT473.02

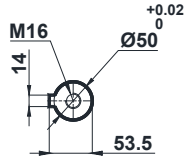
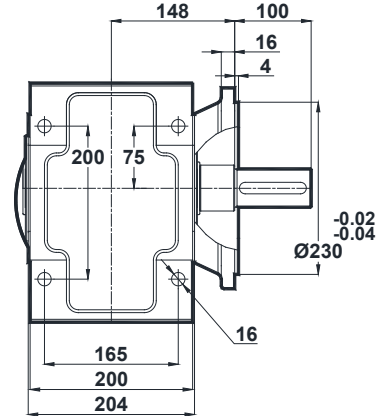
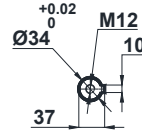
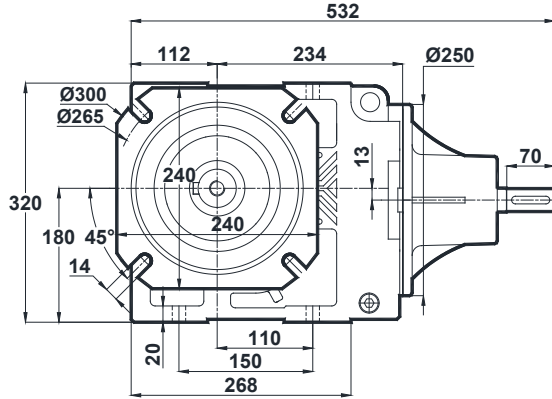

Opsiyonel flanş ölçüleri için sayfa 587'ye bakınız.
Please see on page 587 for optional flange dimensions
Siehe Seite 587 für auswählbare Flanschabmessungen

KT473.03

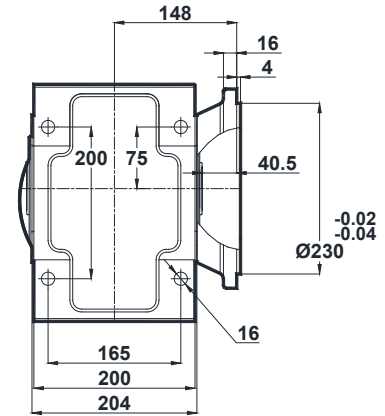
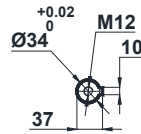
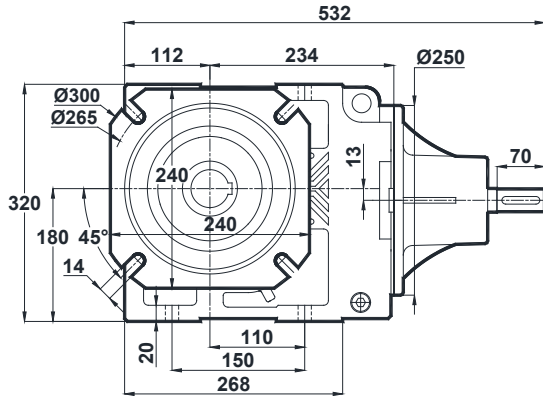

Std.

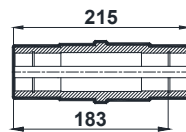

Ops.

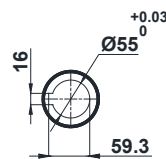

Opsiyonel flanş ölçüleri için sayfa 587'ye bakınız.
Please see on page 587 for optional flange dimensions
Siehe Seite 587 für auswählbare Flanschabmessungen

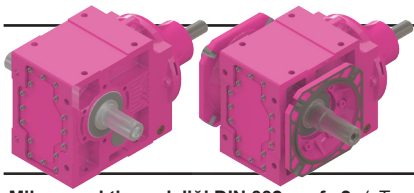

Ölçü Sayfaları Dimension Pages Abmessungsseiten

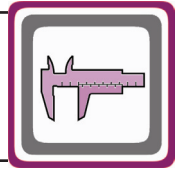

-Mil ucu çektirme deliği DIN 332 sayfa 2 / Tapped center hole to DIN 332, sheet 2 / Zentrierung mit Gewinde DIN 332, Blatt 2

KT473.04

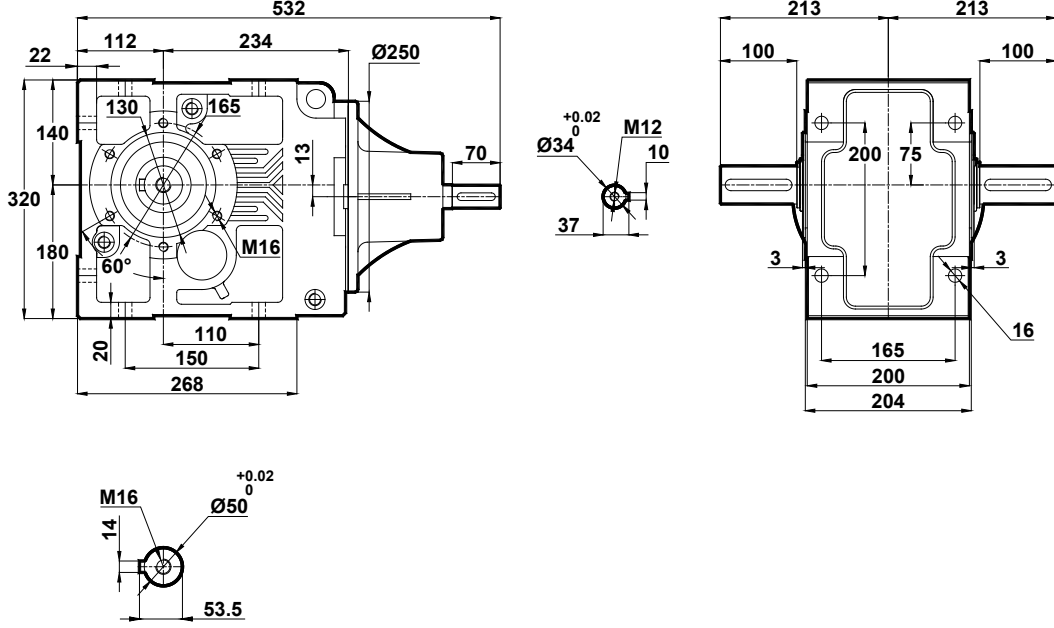

KT473.05

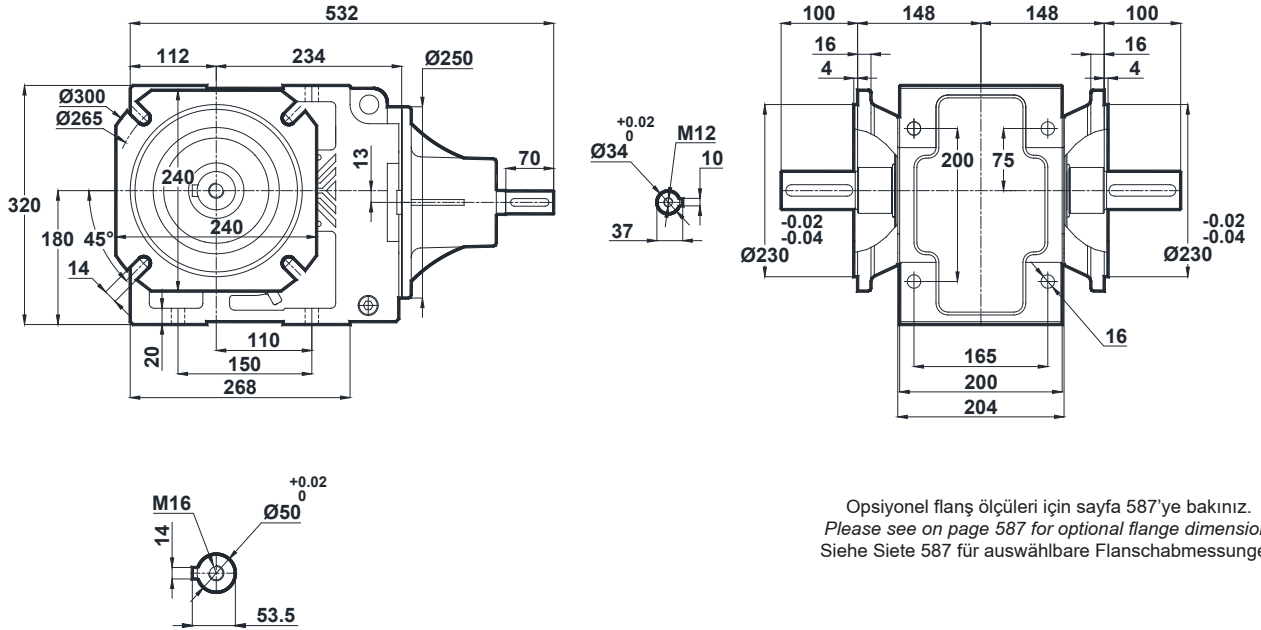

Opsiyonel flanş ölçüleri için sayfa 587'ye bakınız.
Please see on page 587 for optional flange dimensions
Siehe Seite 587 für auswählbare Flanschabmessungen



Ölçü Sayfaları

Dimension Pages

Abmessungsseiten

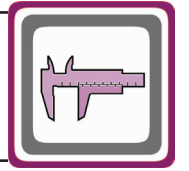

-Mil ucu çekirme deliği DIN 332 sayfa 2 / Tapped center hole to DIN 332, sheet 2 / Zentrierung mit Gewinde DIN 332, Blatt 2

KT474.00

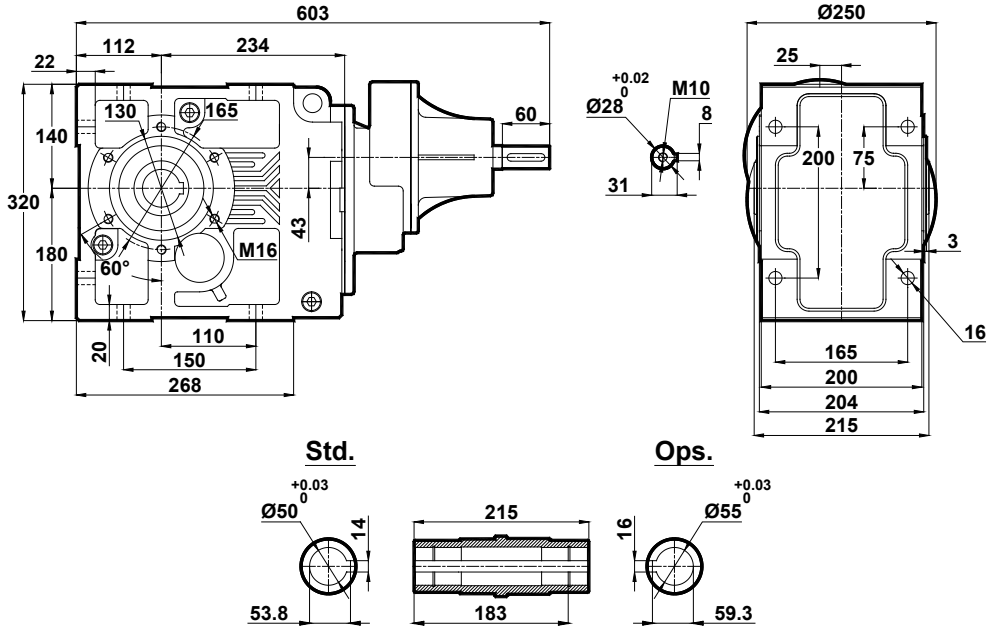

KT474.01

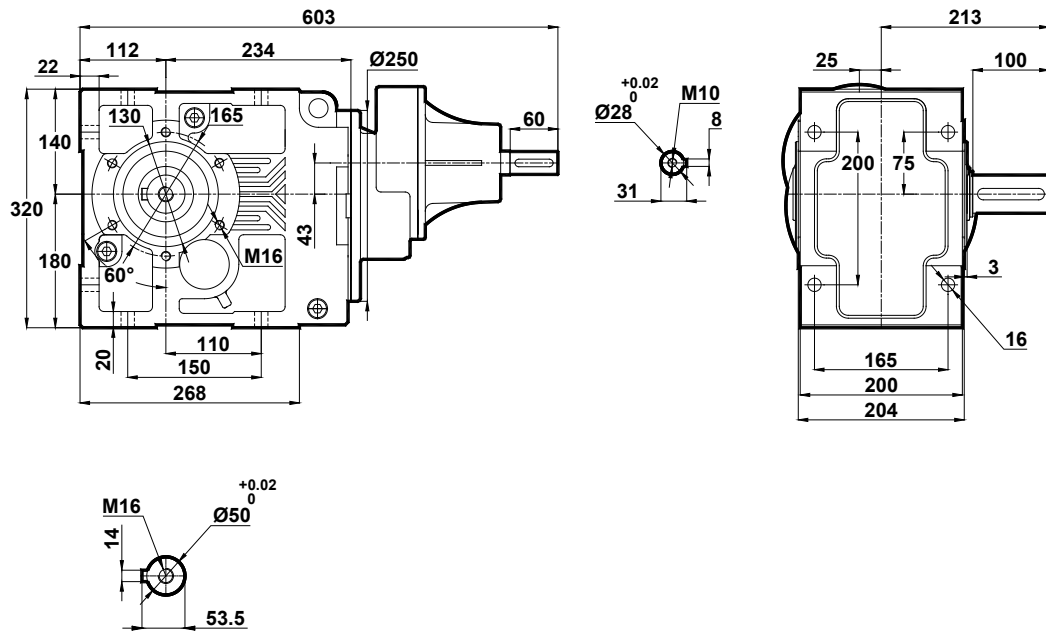



Ölçü Sayfaları

Dimension Pages

Abmessungsseiten



-Mil ucu çektirme deliği DIN 332 sayfa 2 / Tapped center hole to DIN 332, sheet 2 / Zentrierung mit Gewinde DIN 332, Blatt 2

KT474.02

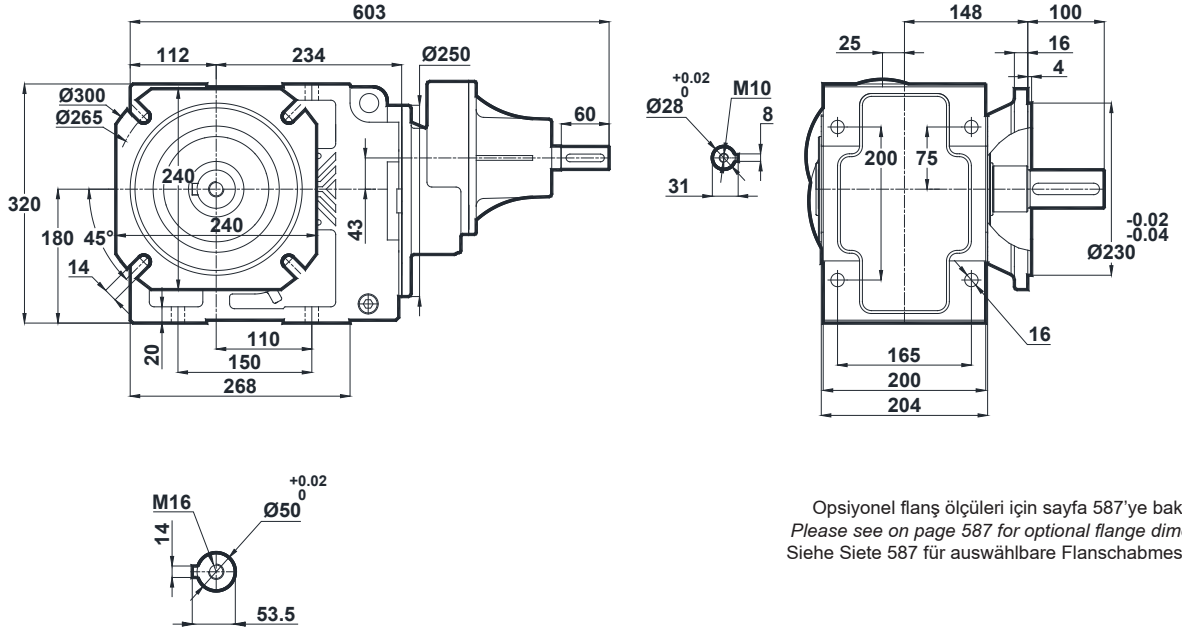

Opsiyonel flanş ölçüleri için sayfa 587'ye bakınız.
Please see on page 587 for optional flange dimensions
Siehe Seite 587 für auswählbare Flanschabmessungen

KT474.03

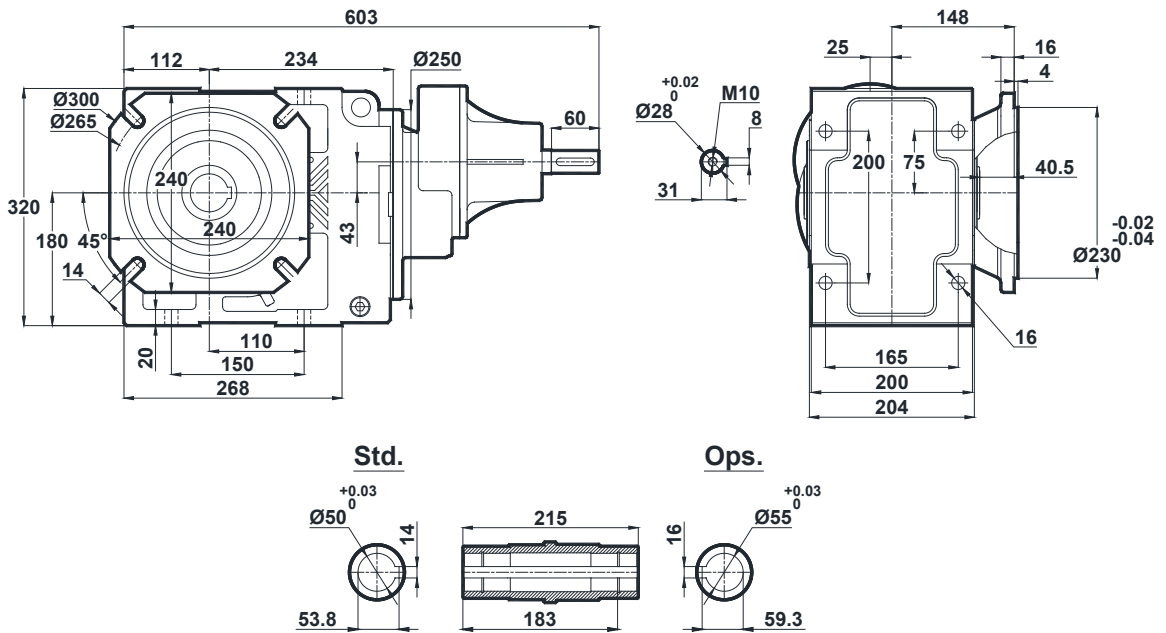

Std.

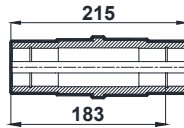
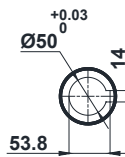

Ops.

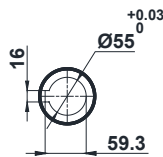

Opsiyonel flanş ölçüleri için sayfa 587'ye bakınız.
Please see on page 587 for optional flange dimensions
Siehe Seite 587 für auswählbare Flanschabmessungen

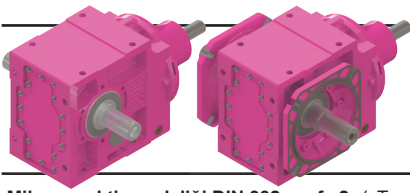

Ölçü Sayfaları Dimension Pages Abmessungsseiten

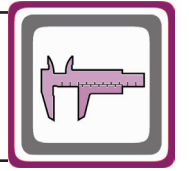

-Mil ucu çektirme deliği DIN 332 sayfa 2 / Tapped center hole to DIN 332, sheet 2 / Zentrierung mit Gewinde DIN 332, Blatt 2

KT474.04

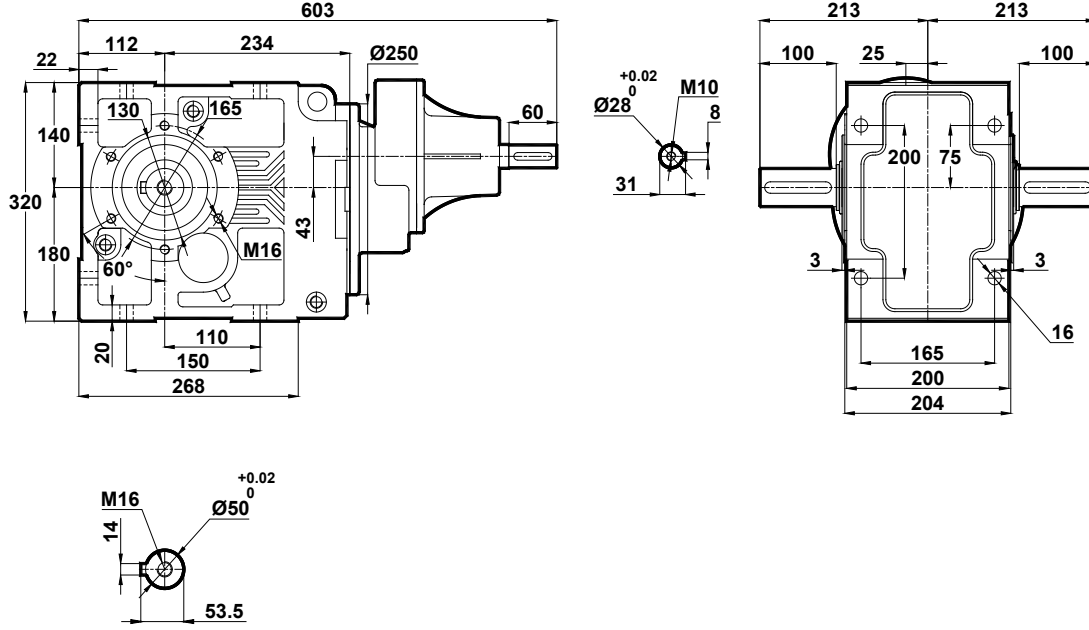

KT474.05

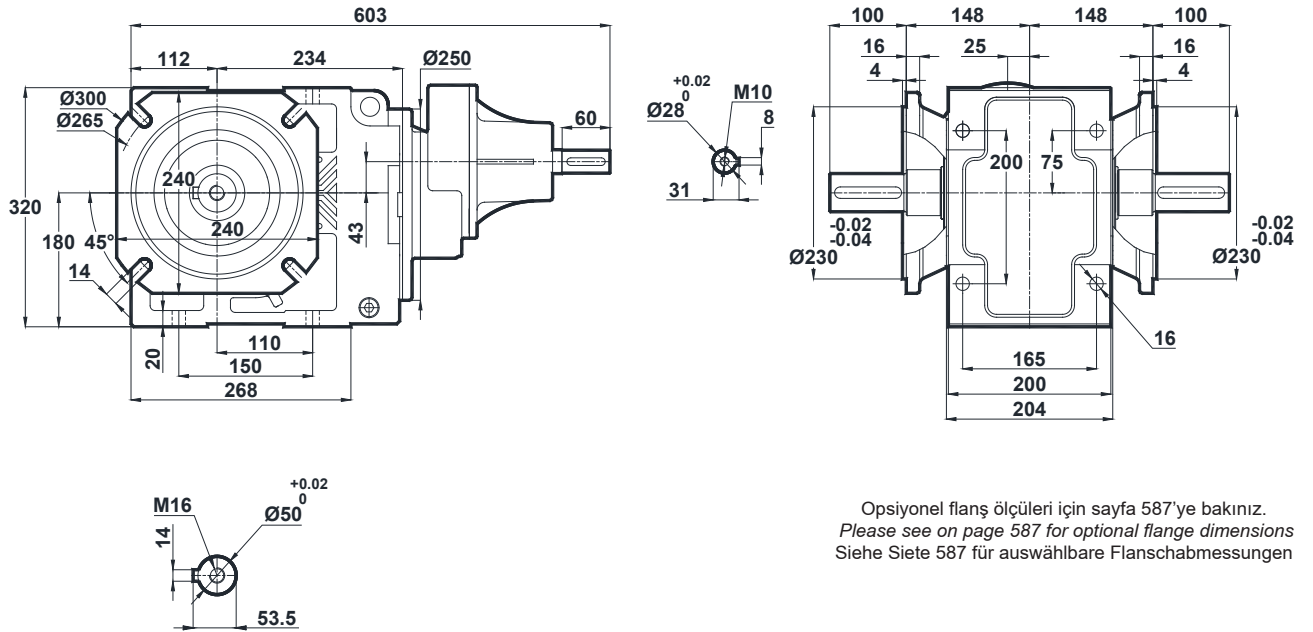

Opsiyonel flanş ölçüleri için sayfa 587'ye bakınız.
Please see on page 587 for optional flange dimensions
Siehe Seite 587 für auswählbare Flanschabmessungen



Ölçü Sayfaları Dimension Pages Abmessungenseiten



-Mil ucu çekirme deliği DIN 332 sayfa 2 / Tapped center hole to DIN 332, sheet 2 / Zentrierung mit Gewinde DIN 332, Blatt 2

KT474.08

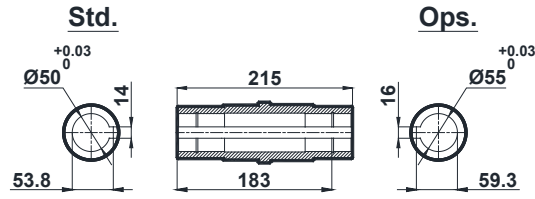
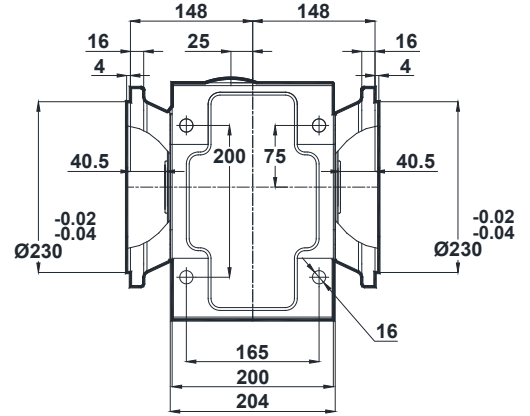
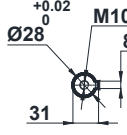
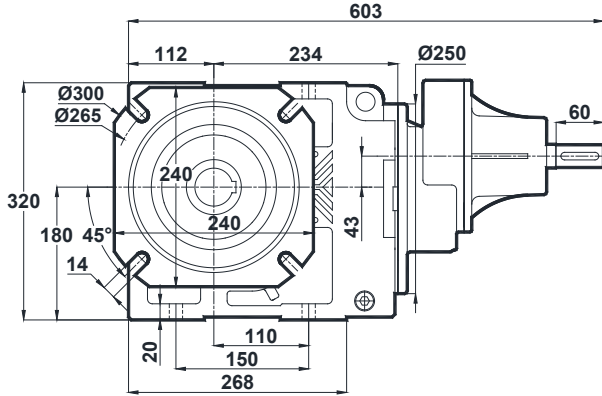

Opsiyonel flanş ölçüleri için sayfa 587'ye bakınız.
Please see on page 587 for optional flange dimensions
Siehe Seite 587 für auswählbare Flanschabmessungen



Ölçü Sayfaları

Dimension Pages

Abmessungsseiten

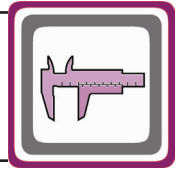

-Mil ucu çekirme deliği DIN 332 sayfa 2 / Tapped center hole to DIN 332, sheet 2 / Zentrierung mit Gewinde DIN 332, Blatt 2

KT475.00
KT476.00

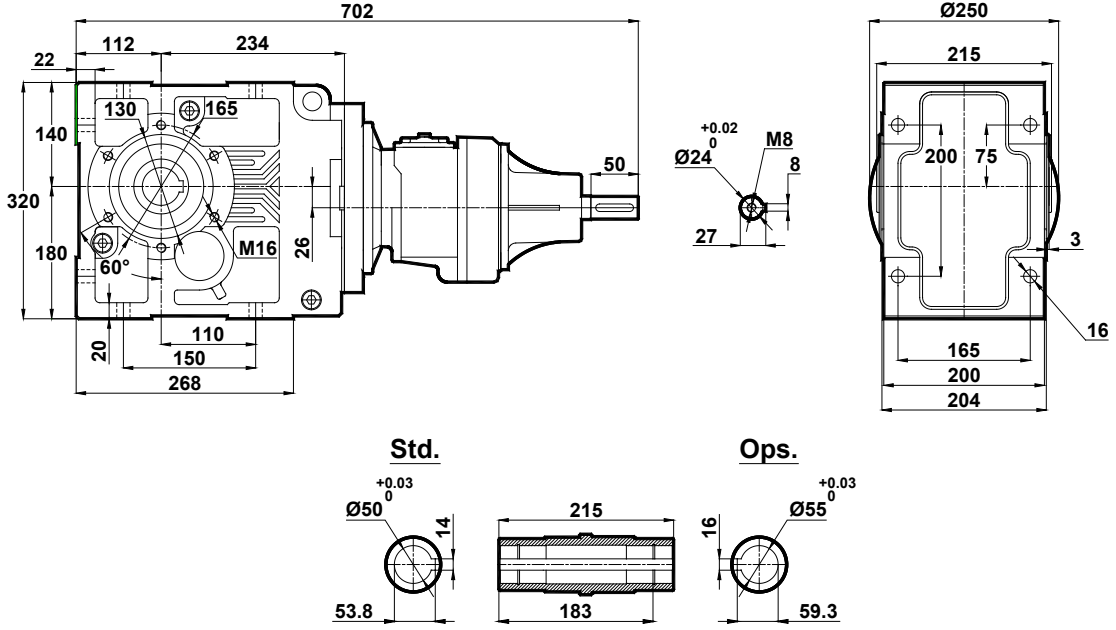

KT475.01
KT476.01

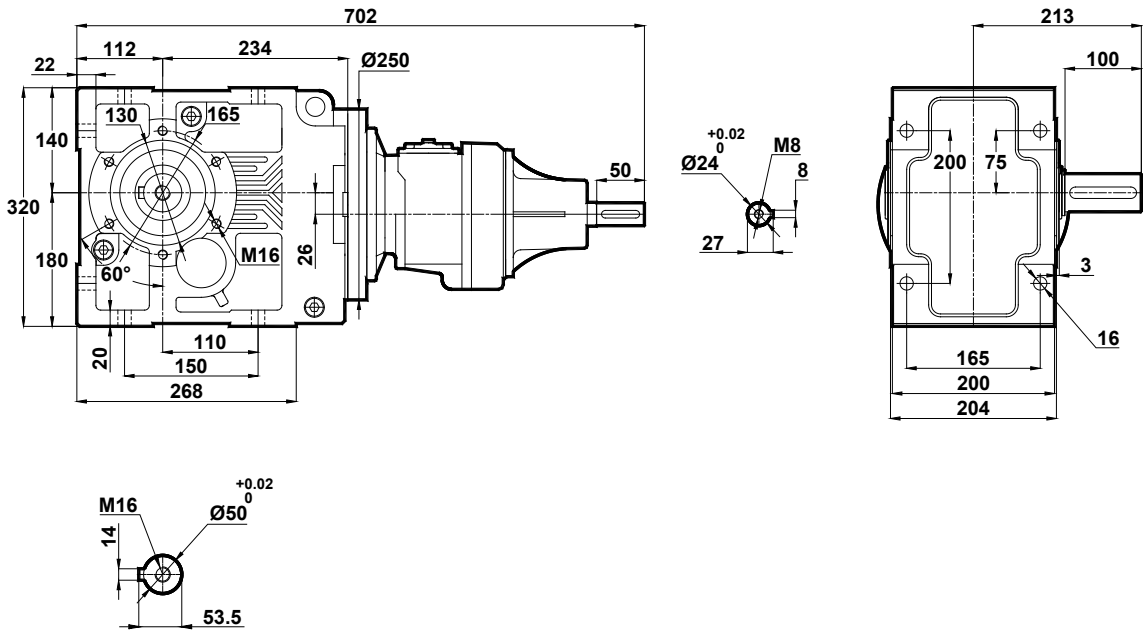



Ölçü Sayfaları Dimension Pages Abmessungenseiten



-Mil ucu çekirme deliği DIN 332 sayfa 2 / Tapped center hole to DIN 332, sheet 2 / Zentrierung mit Gewinde DIN 332, Blatt 2

KT475.02
KT476.02

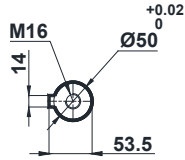
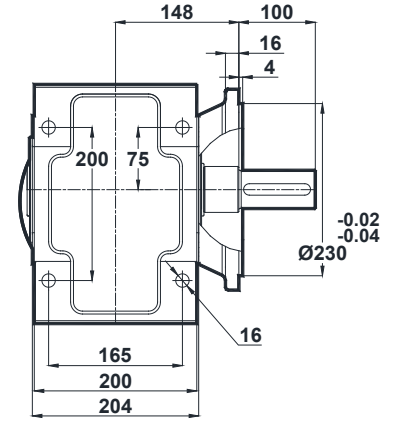
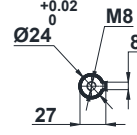
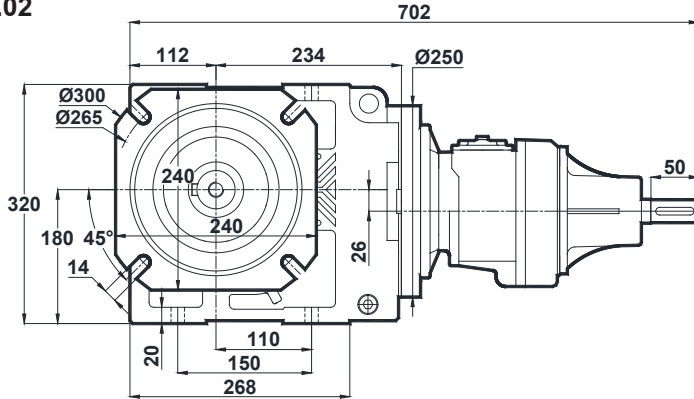

Opsiyonel flanş ölçüleri için sayfa 587'ye bakınız.
Please see on page 587 for optional flange dimensions
Siehe Seite 587 für auswählbare Flanschabmessungen

KT475.03
KT476.03

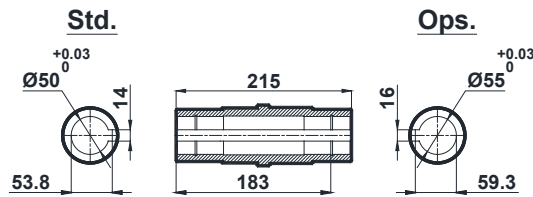
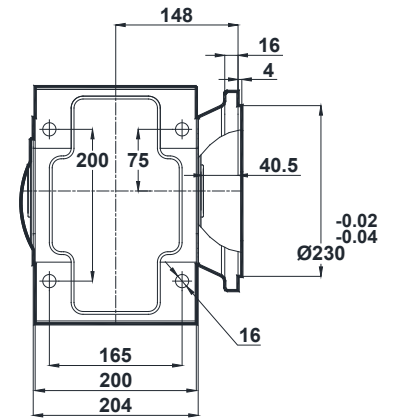
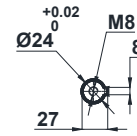
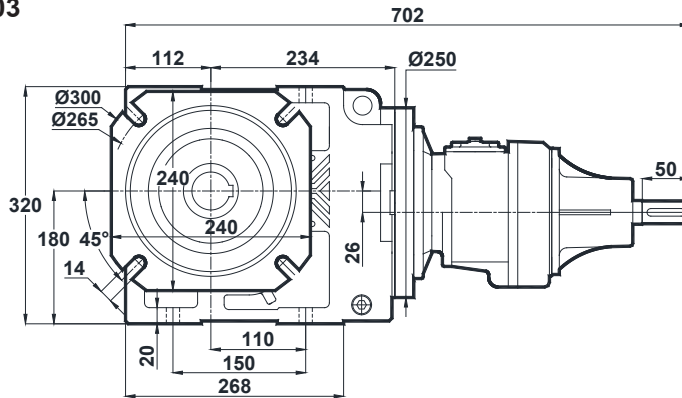

Opsiyonel flanş ölçüleri için sayfa 587'ye bakınız.
Please see on page 587 for optional flange dimensions
Siehe Seite 587 für auswählbare Flanschabmessungen

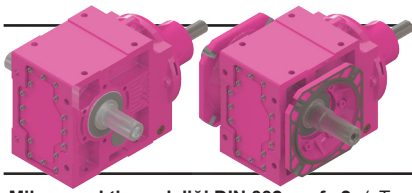

Ölçü Sayfaları Dimension Pages Abmessungenseiten

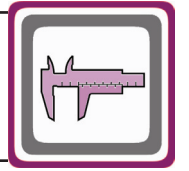

-Mil ucu çekirme deliği DIN 332 sayfa 2 / Tapped center hole to DIN 332, sheet 2 / Zentrierung mit Gewinde DIN 332, Blatt 2

KT475.04
KT476.04

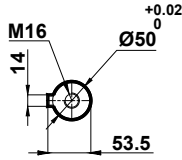
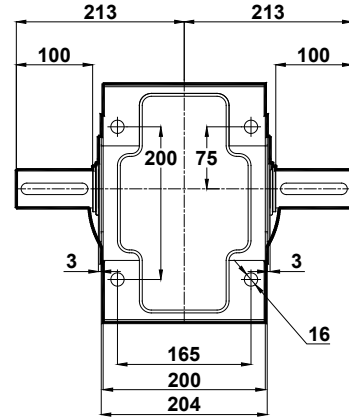
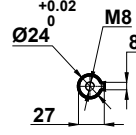
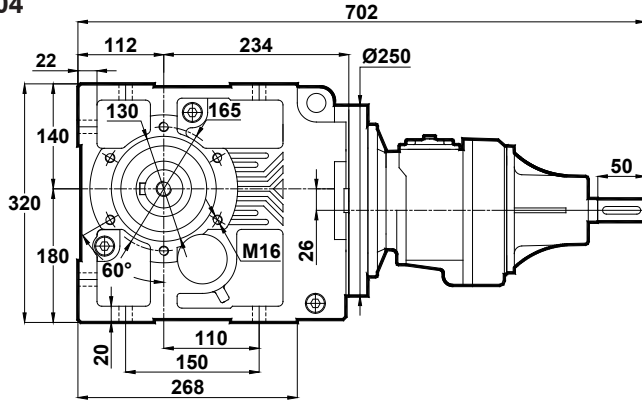

KT475.05
KT476.05

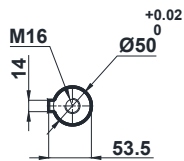
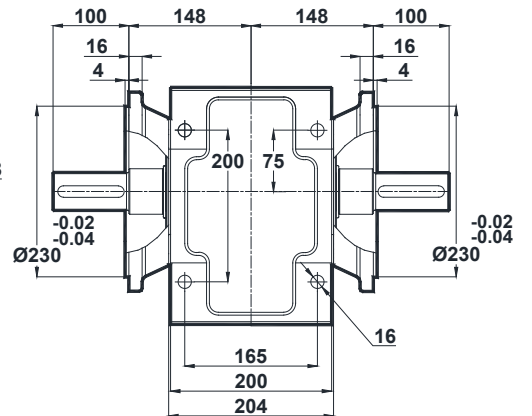
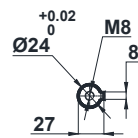
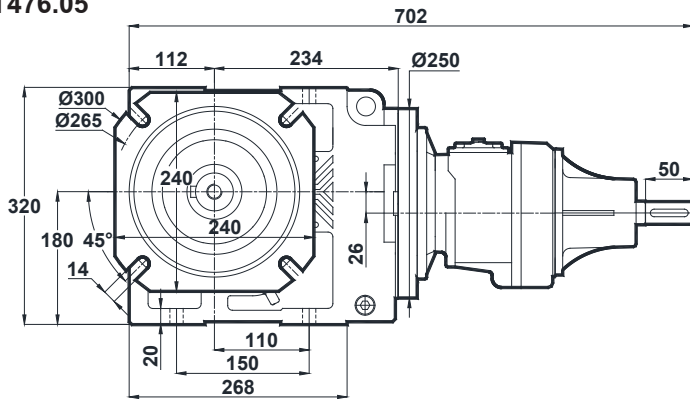

Opsiyonel flanş ölçüleri için sayfa 587'ye bakınız.
Please see on page 587 for optional flange dimensions
Siehe Seite 587 für auswählbare Flanschabmessungen



Ölçü Sayfaları Dimension Pages Abmessungenseiten



-Mil ucu çekirme deliği DIN 332 sayfa 2 / Tapped center hole to DIN 332, sheet 2 / Zentrierung mit Gewinde DIN 332, Blatt 2

KT475.08
KT476.08

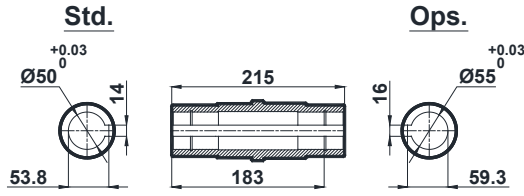
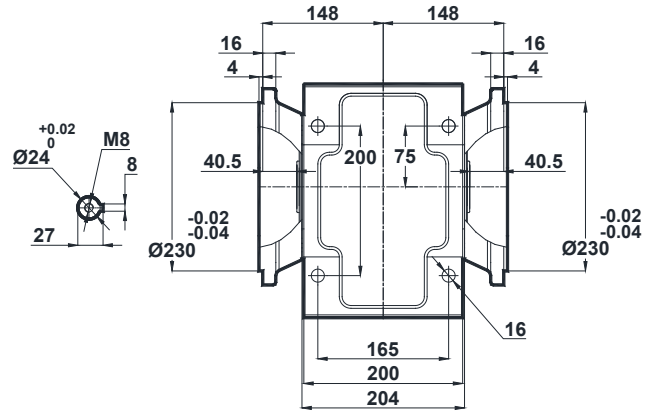
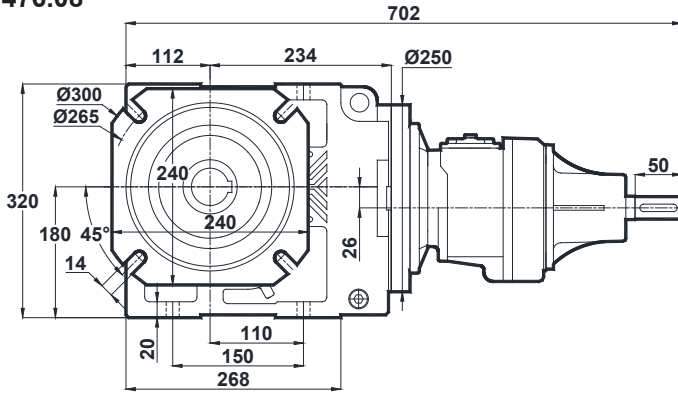

Opsiyonel flanş ölçüleri için sayfa 587'ye bakınız.
Please see on page 587 for optional flange dimensions
Siehe Seite 587 für auswählbare Flanschabmessungen



Ölçü Sayfaları

Dimension Pages

Abmessungsseiten

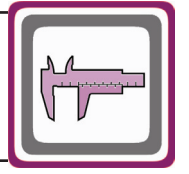

-Mil ucu çekirme deliği DIN 332 sayfa 2 / Tapped center hole to DIN 332, sheet 2 / Zentrierung mit Gewinde DIN 332, Blatt 2

KT573.00

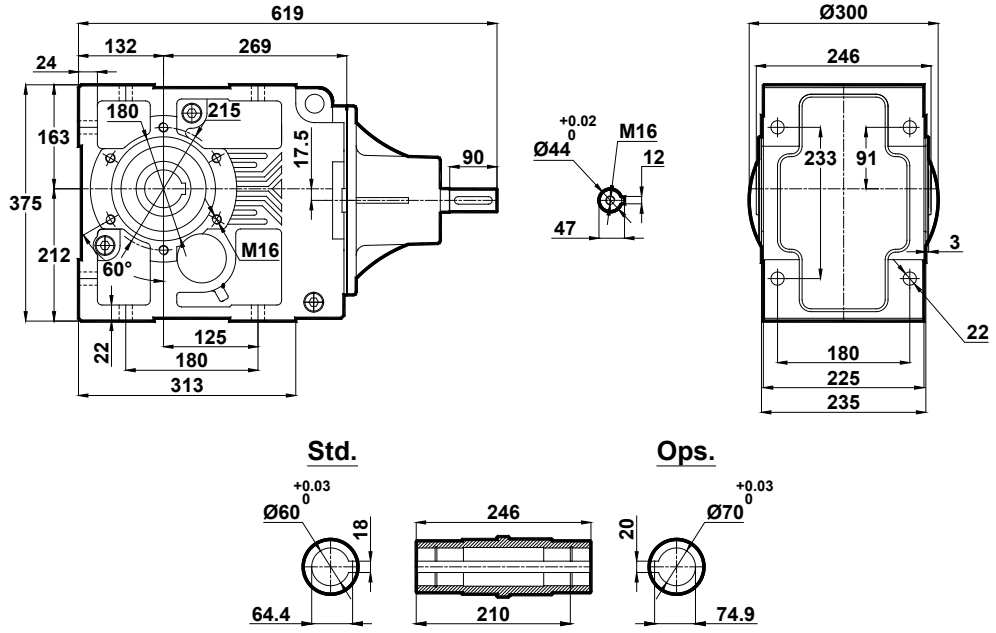

KT573.01

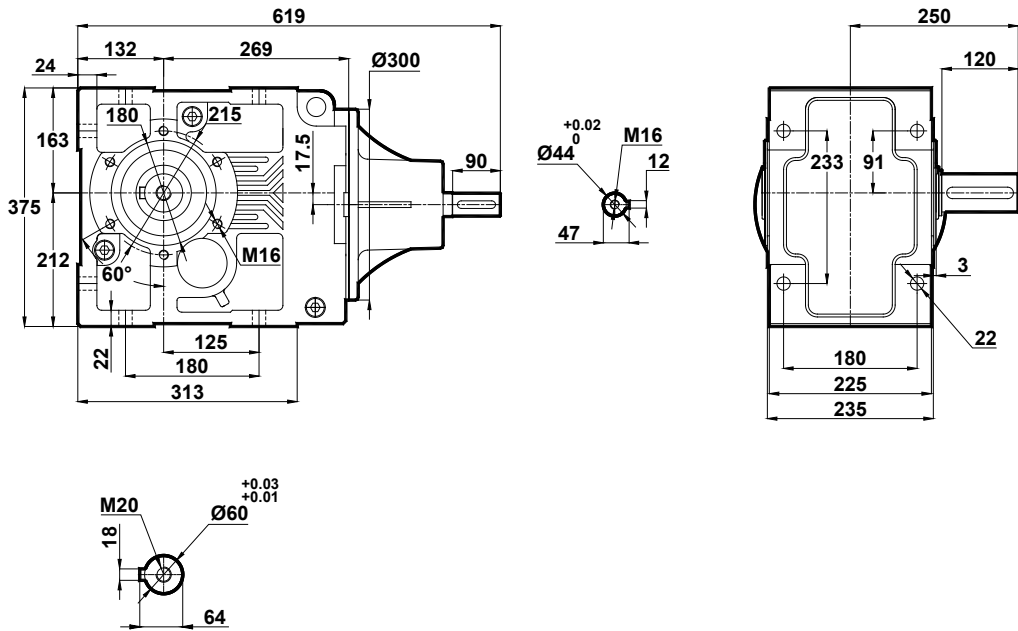



Ölçü Sayfaları

Dimension Pages

Abmessungsseiten



-Mil ucu çekirme deliği DIN 332 sayfa 2 / Tapped center hole to DIN 332, sheet 2 / Zentrierung mit Gewinde DIN 332, Blatt 2

KT573.02

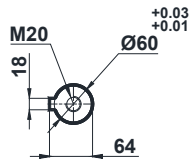
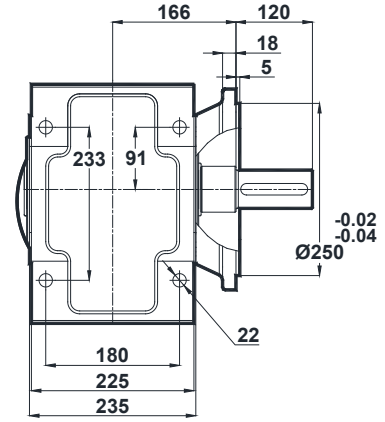
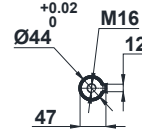
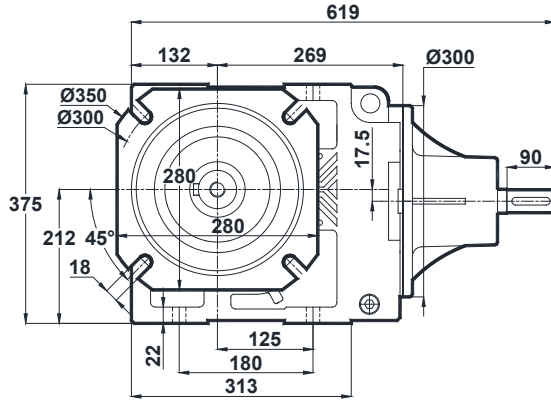

Opsiyonel flanş ölçüleri için sayfa 587'ye bakınız.
Please see on page 587 for optional flange dimensions
Siehe Seite 587 für auswählbare Flanschabmessungen

KT573.03

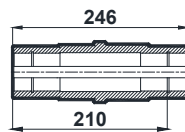
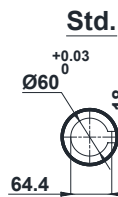
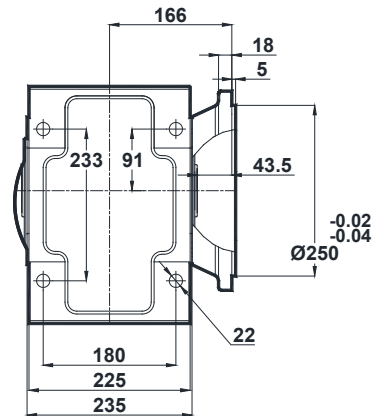
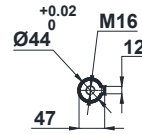
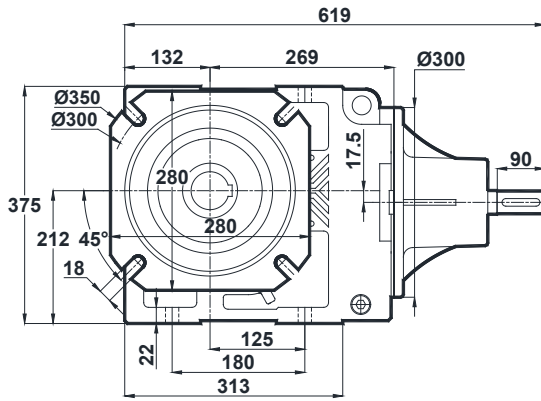

Opsiyonel flanş ölçüleri için sayfa 587'ye bakınız.
Please see on page 587 for optional flange dimensions
Siehe Seite 587 für auswählbare Flanschabmessungen

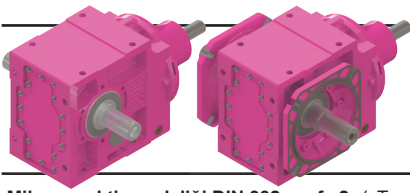

Ölçü Sayfaları Dimension Pages Abmessungsseiten

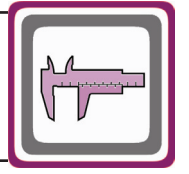

-Mil ucu çektirme deliği DIN 332 sayfa 2 / Tapped center hole to DIN 332, sheet 2 / Zentrierung mit Gewinde DIN 332, Blatt 2

KT573.04

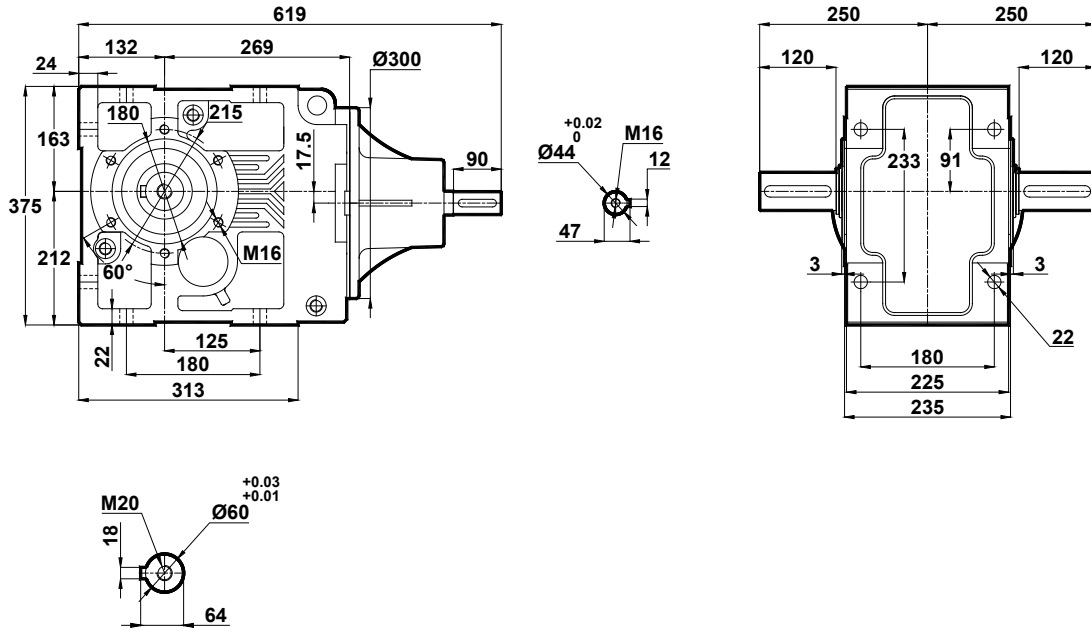

KT573.05

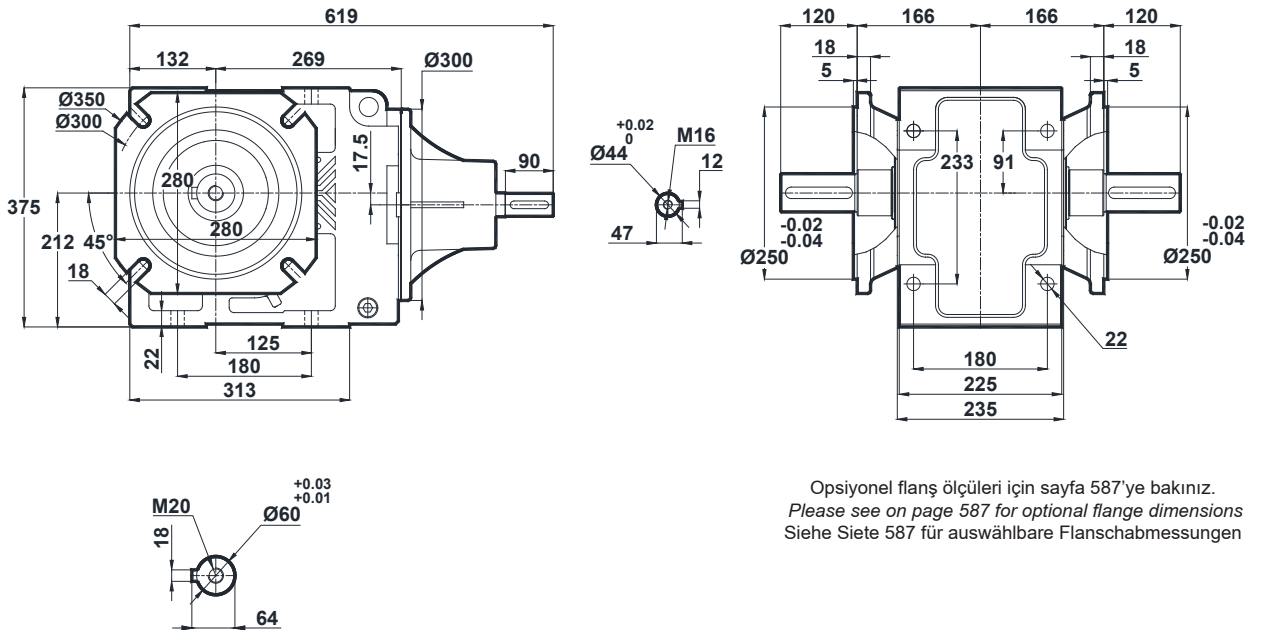

Opsiyonel flanş ölçüleri için sayfa 587'ye bakınız.
Please see on page 587 for optional flange dimensions
Siehe Seite 587 für auswählbare Flanschabmessungen



Ölçü Sayfaları Dimension Pages Abmessungenseiten



-Mil ucu çektirme deliği DIN 332 sayfa 2 / Tapped center hole to DIN 332, sheet 2 / Zentrierung mit Gewinde DIN 332, Blatt 2

KT573.08

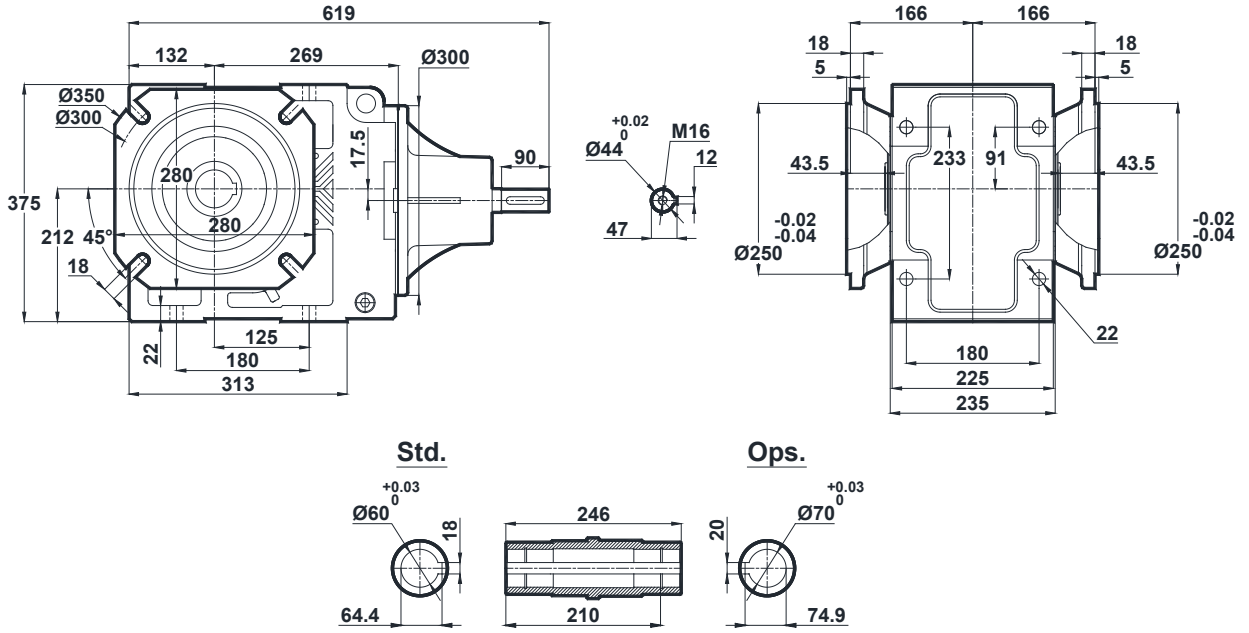

Opsiyonel flanş ölçüleri için sayfa 587'ye bakınız.
Please see on page 587 for optional flange dimensions
Siehe Seite 587 für auswählbare Flanschabmessungen



Ölçü Sayfaları

Dimension Pages

Abmessungsseiten

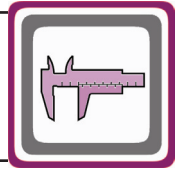

-Mil ucu çekirme deliği DIN 332 sayfa 2 / Tapped center hole to DIN 332, sheet 2 / Zentrierung mit Gewinde DIN 332, Blatt 2

KT574.00

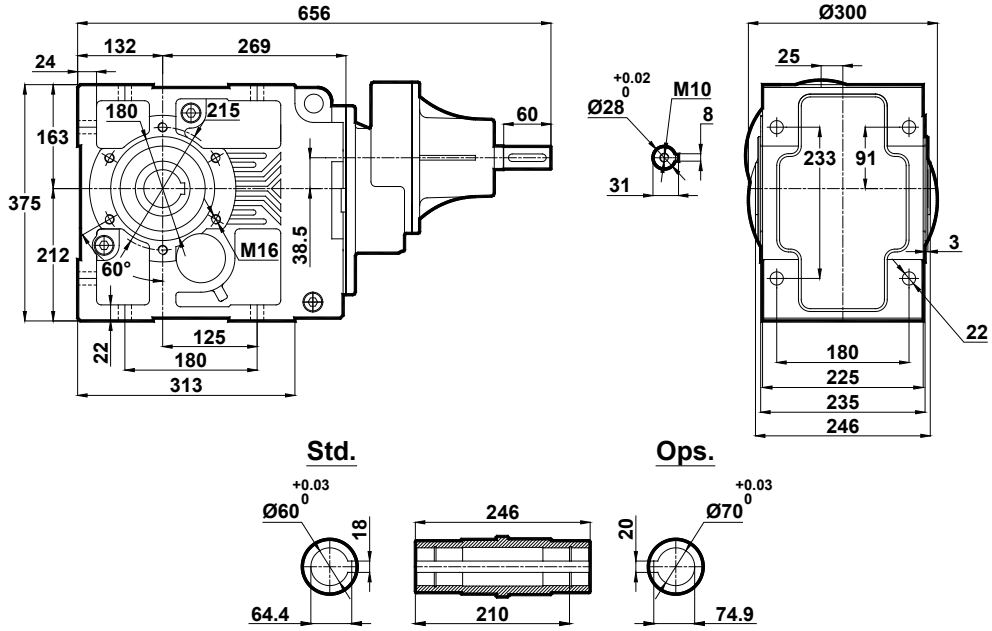

KT574.01

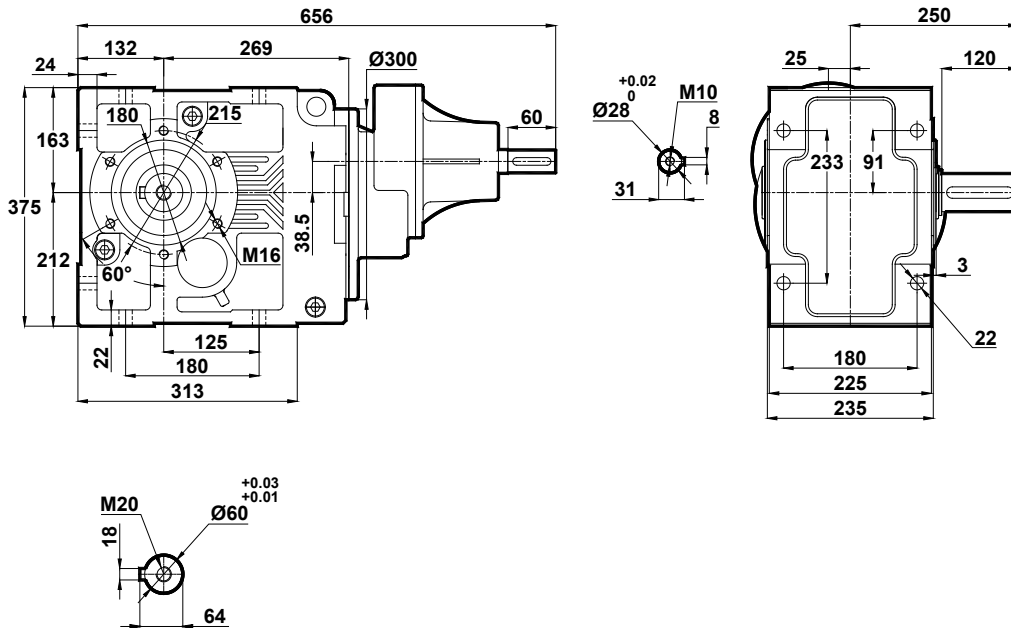

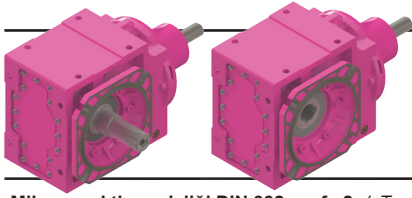

Ölçü Sayfaları Dimension Pages Abmessungenseiten



-Mil ucu çekirme deliği DIN 332 sayfa 2 / Tapped center hole to DIN 332, sheet 2 / Zentrierung mit Gewinde DIN 332, Blatt 2

KT574.02

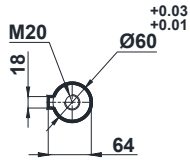
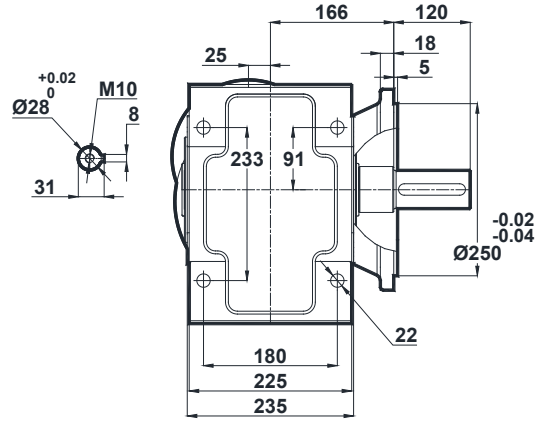
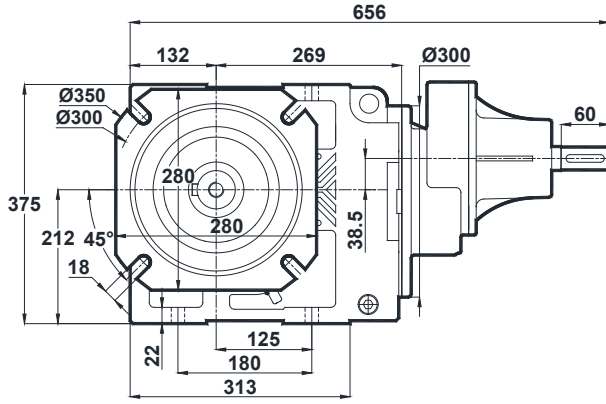

Opsiyonel flanş ölçüleri için sayfa 587'ye bakınız.
Please see on page 587 for optional flange dimensions
Siehe Seite 587 für auswählbare Flanschabmessungen

KT574.03

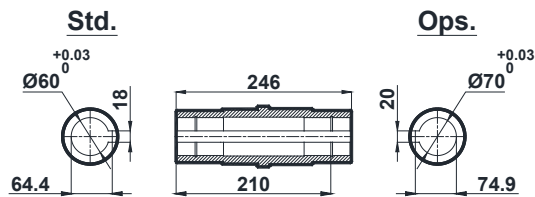
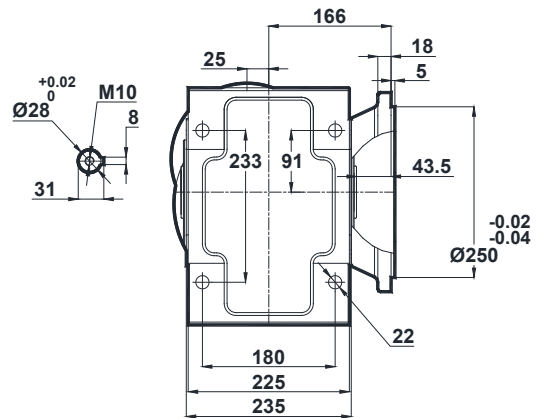
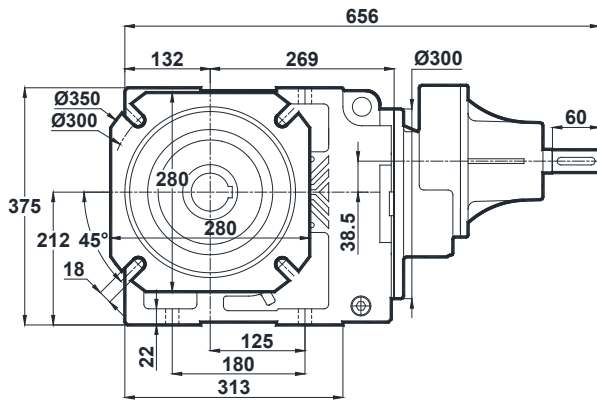

Opsiyonel flanş ölçüleri için sayfa 587'ye bakınız.
Please see on page 587 for optional flange dimensions
Siehe Seite 587 für auswählbare Flanschabmessungen

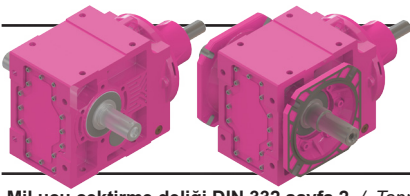

Ölçü Sayfaları Dimension Pages Abmessungsseiten

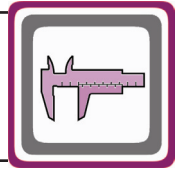

-Mil ucu çekirme deliği DIN 332 sayfa 2 / Tapped center hole to DIN 332, sheet 2 / Zentrierung mit Gewinde DIN 332, Blatt 2

KT574.04

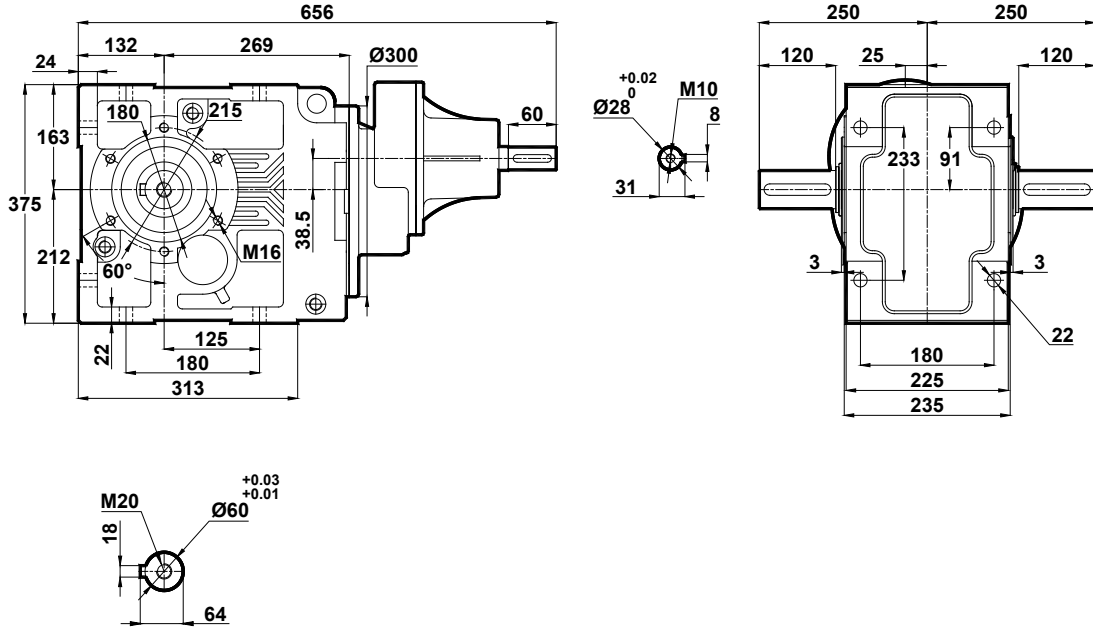

KT574.05

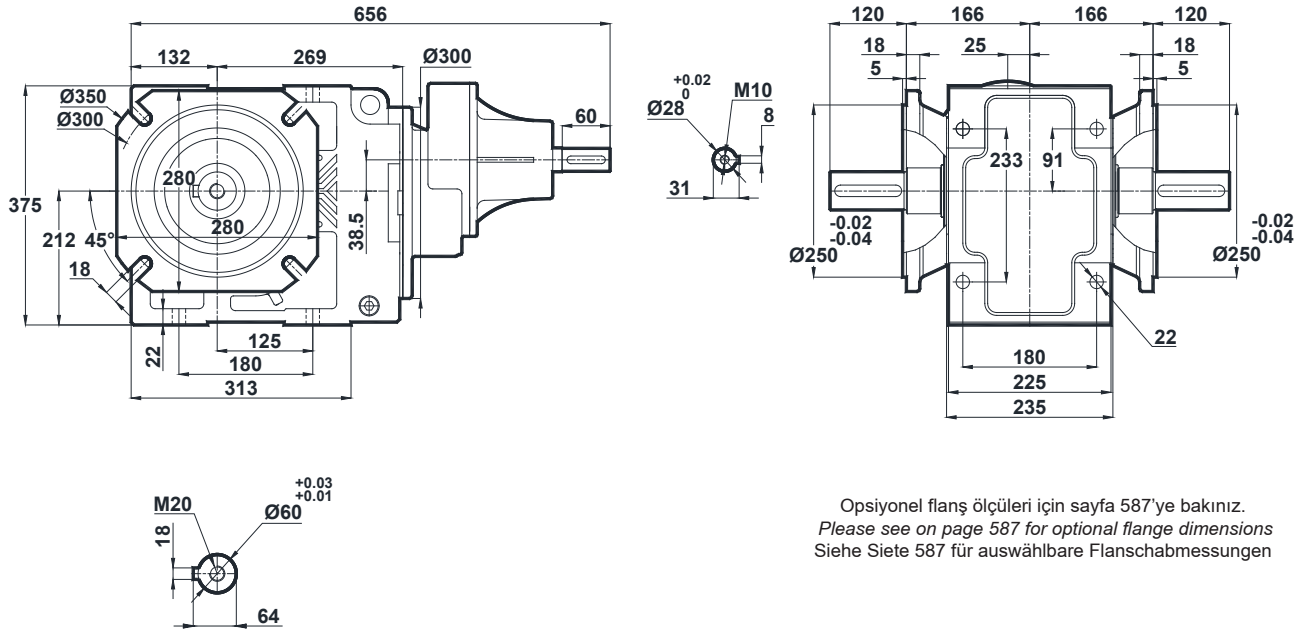

Opsiyonel flanş ölçüleri için sayfa 587'ye bakınız.
Please see on page 587 for optional flange dimensions
Siehe Seite 587 für auswählbare Flanschabmessungen



Ölçü Sayfaları Dimension Pages Abmessungenseiten

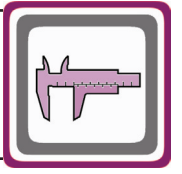

-Mil ucu çektirme deliği DIN 332 sayfa 2 / Tapped center hole to DIN 332, sheet 2 / Zentrierung mit Gewinde DIN 332, Blatt 2

KT574.08

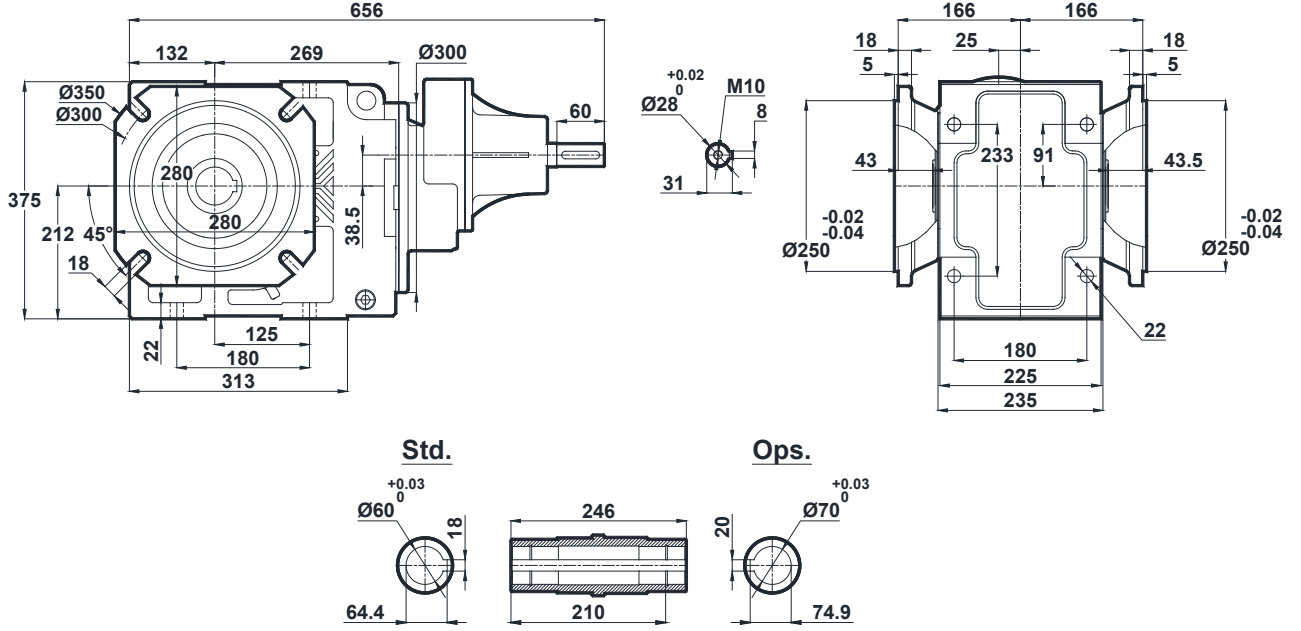

Opsiyonel flanş ölçüleri için sayfa 587'ye bakınız.
Please see on page 587 for optional flange dimensions
Siehe Seite 587 für auswählbare Flanschabmessungen



Ölçü Sayfaları

Dimension Pages

Abmessungenseiten

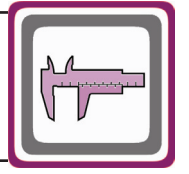

-Mil ucu çekirme deliği DIN 332 sayfa 2 / Tapped center hole to DIN 332, sheet 2 / Zentrierung mit Gewinde DIN 332, Blatt 2

KT575.00
KT576.00

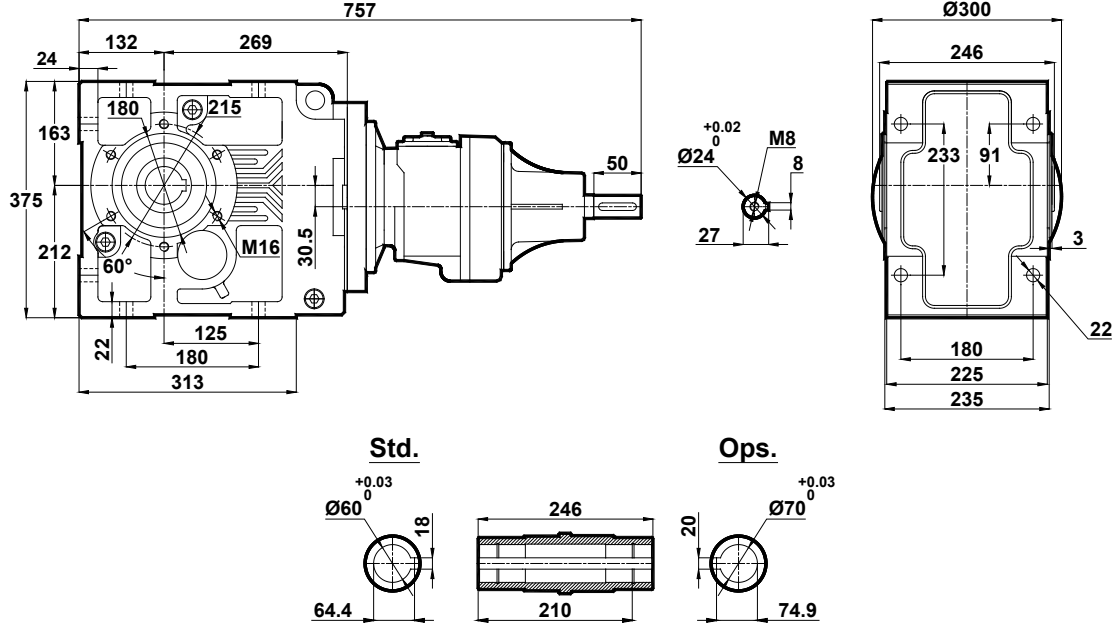

KT575.01
KT576.01

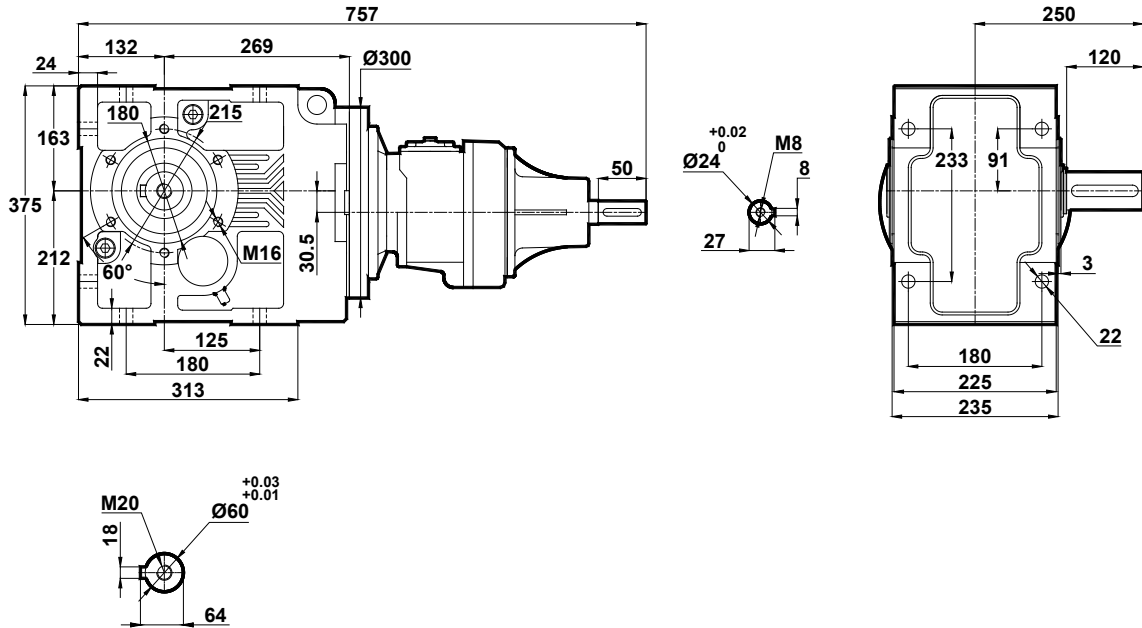



Ölçü Sayfaları

Dimension Pages

Abmessungsseiten



-Mil ucu çekirme deliği DIN 332 sayfa 2 / Tapped center hole to DIN 332, sheet 2 / Zentrierung mit Gewinde DIN 332, Blatt 2

KT575.02
KT576.02

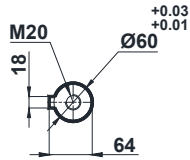
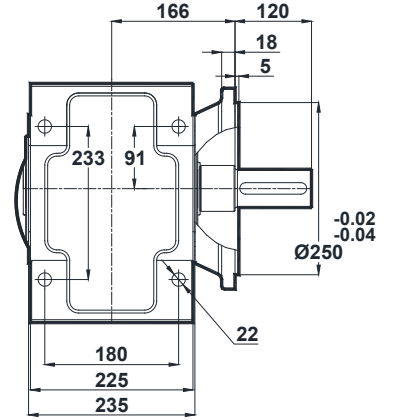
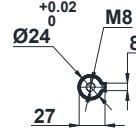
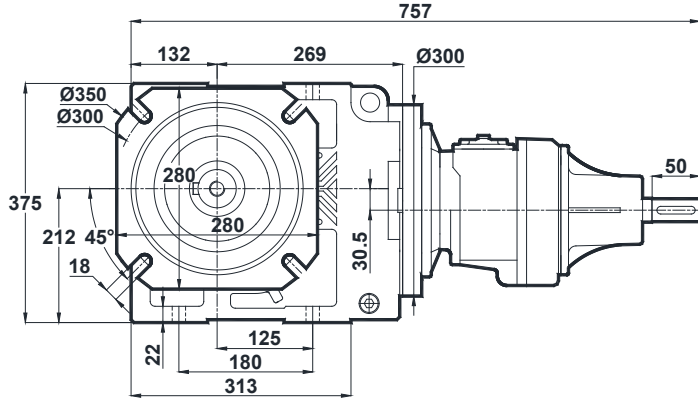

Opsiyonel flanş ölçüleri için sayfa 587'ye bakınız.
Please see on page 587 for optional flange dimensions
Siehe Seite 587 für auswählbare Flanschabmessungen

KT575.03
KT576.03

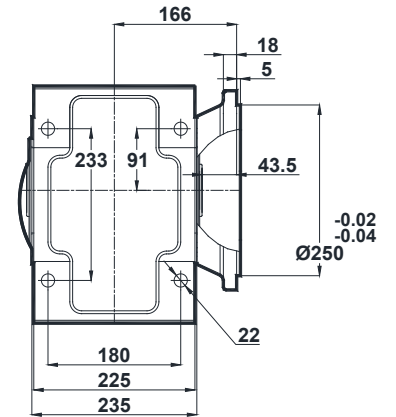
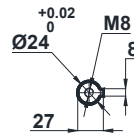
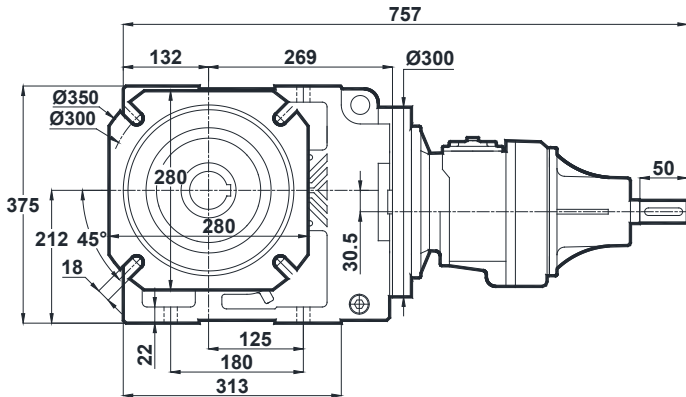

Std.

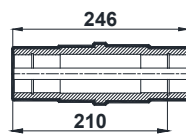

Ops.

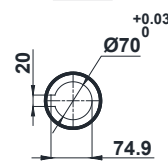

Opsiyonel flanş ölçüleri için sayfa 587'ye bakınız.
Please see on page 587 for optional flange dimensions
Siehe Seite 587 für auswählbare Flanschabmessungen

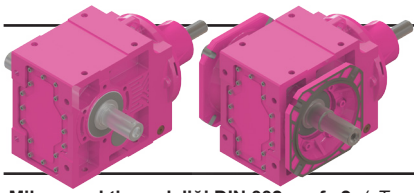

Ölçü Sayfaları

Dimension Pages

Abmessungsseiten

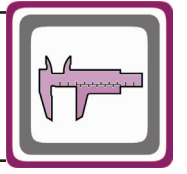

-Mil ucu çekirme deliği DIN 332 sayfa 2 / Tapped center hole to DIN 332, sheet 2 / Zentrierung mit Gewinde DIN 332, Blatt 2

KT575.04
KT576.04

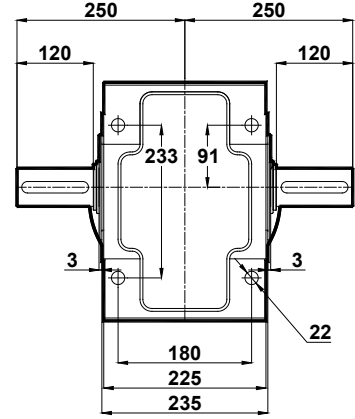
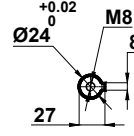
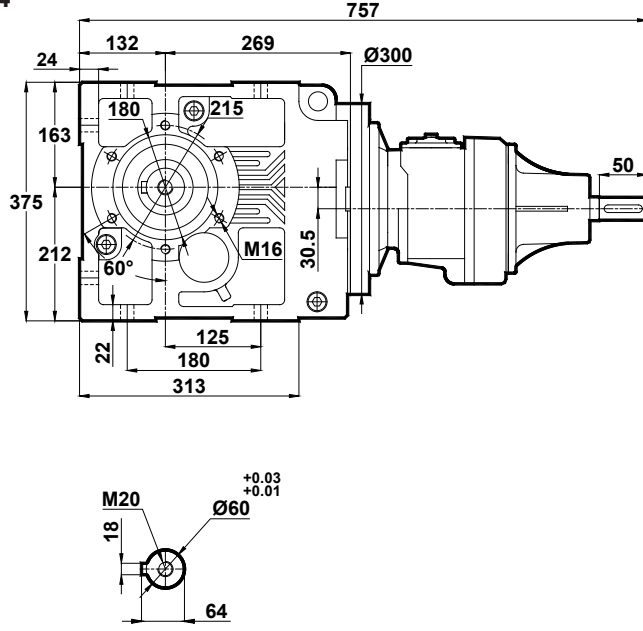

KT575.05
KT576.05

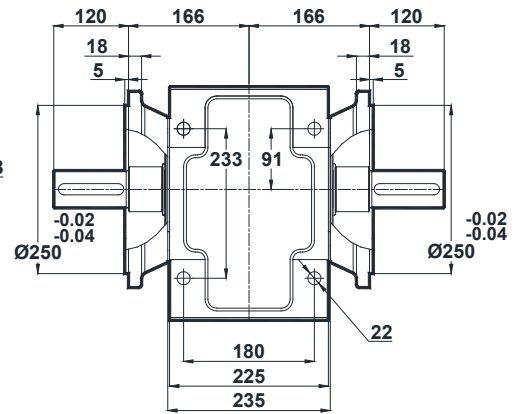
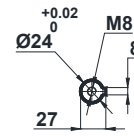
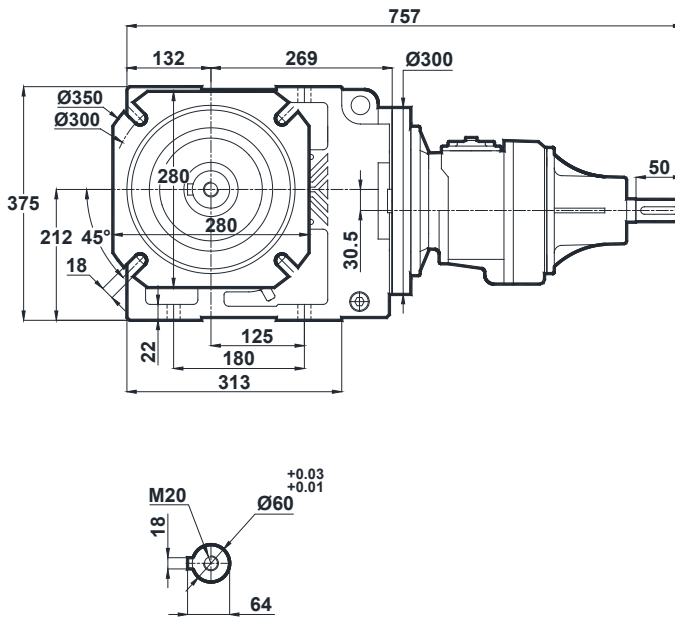

Opsiyonel flanş ölçüleri için sayfa 587'ye bakınız.
Please see on page 587 for optional flange dimensions
Siehe Seite 587 für auswählbare Flanschabmessungen



Ölçü Sayfaları Dimension Pages Abmessungenseiten

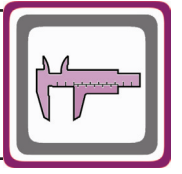

-Mil ucu çektirme deliği DIN 332 sayfa 2 / Tapped center hole to DIN 332, sheet 2 / Zentrierung mit Gewinde DIN 332, Blatt 2

KT575.08
KT576.08

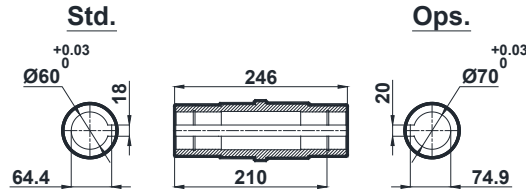
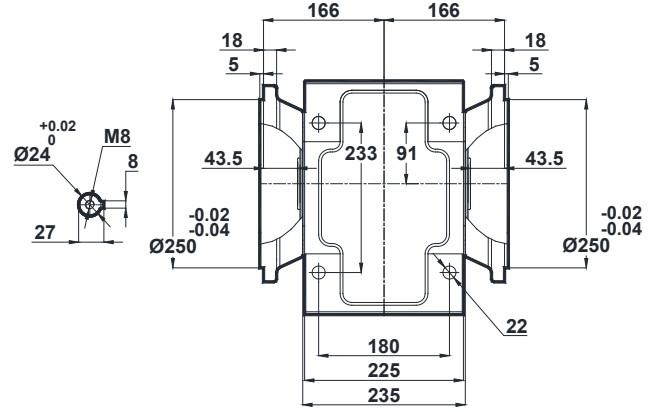
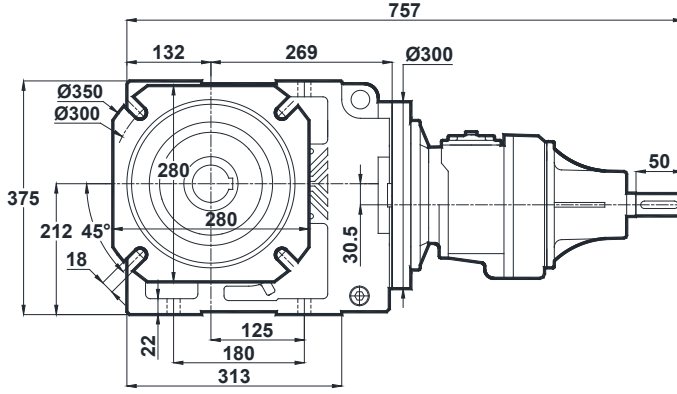

Opsiyonel flanş ölçüleri için sayfa 587'ye bakınız.
Please see on page 587 for optional flange dimensions
Siehe Seite 587 für auswählbare Flanschabmessungen



Ölçü Sayfaları

Dimension Pages

Abmessungsseiten

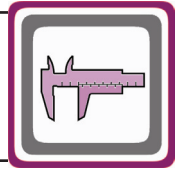

-Mil ucu çekirme deliği DIN 332 sayfa 2 / Tapped center hole to DIN 332, sheet 2 / Zentrierung mit Gewinde DIN 332, Blatt 2

KT673.00

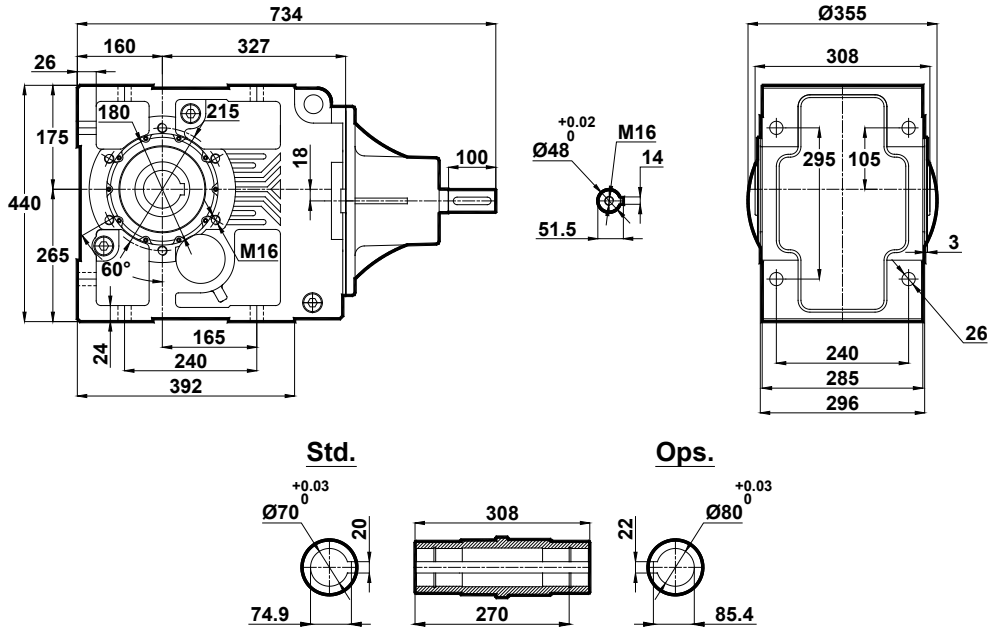

KT673.01

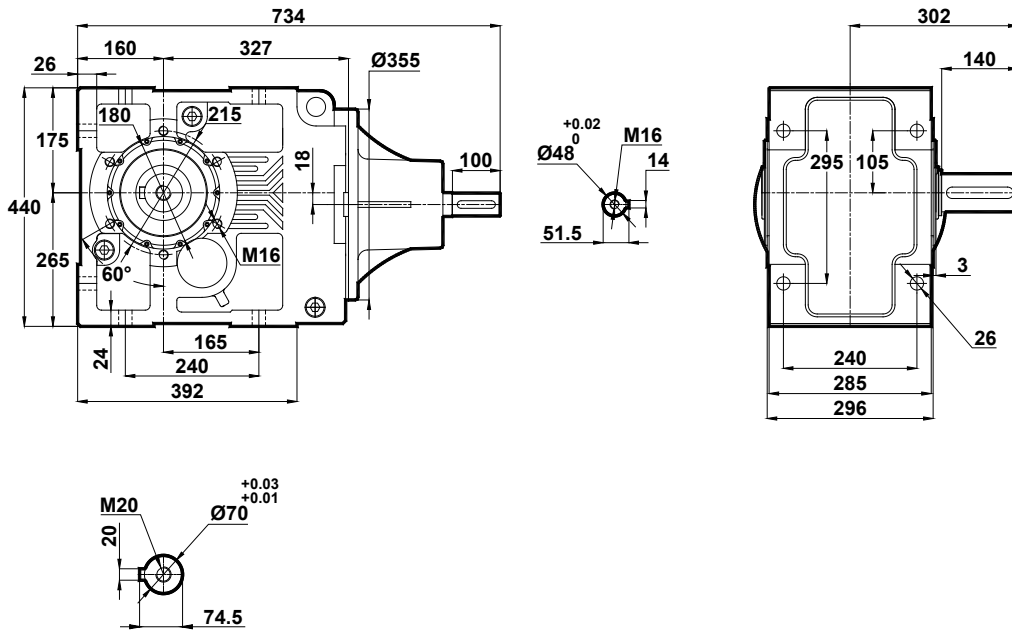



Ölçü Sayfaları

Dimension Pages

Abmessungsseiten



-Mil ucu çekirme deliği DIN 332 sayfa 2 / Tapped center hole to DIN 332, sheet 2 / Zentrierung mit Gewinde DIN 332, Blatt 2

KT673.02

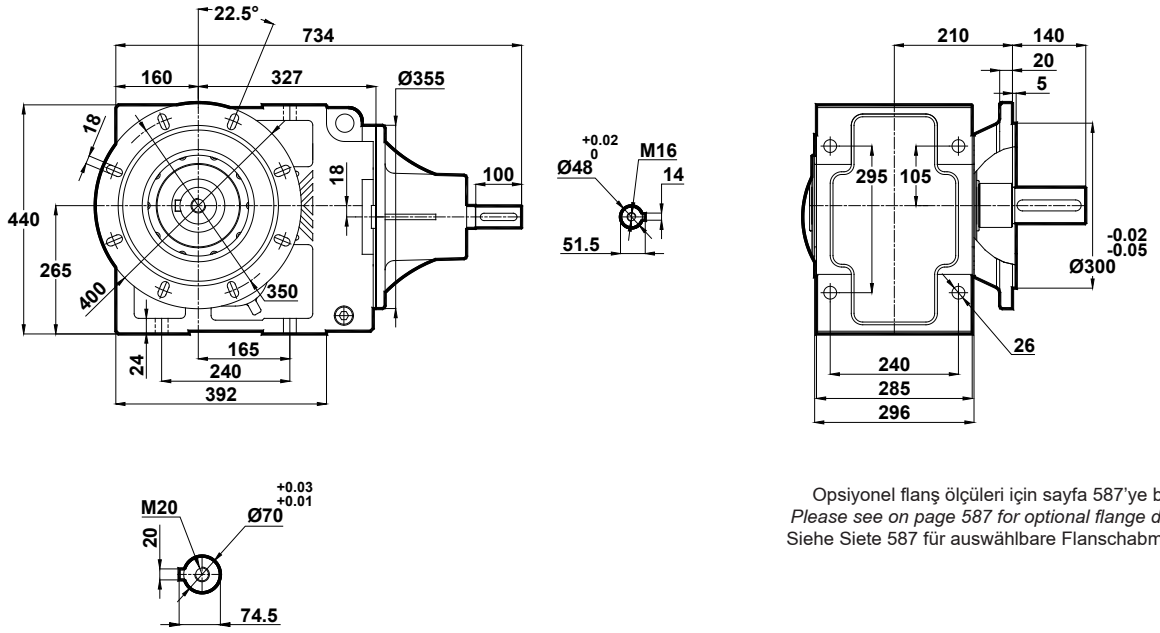

Opsiyonel flanş ölçüleri için sayfa 587'ye bakınız.
Please see on page 587 for optional flange dimensions
Siehe Seite 587 für auswählbare Flanschabmessungen

KT673.03

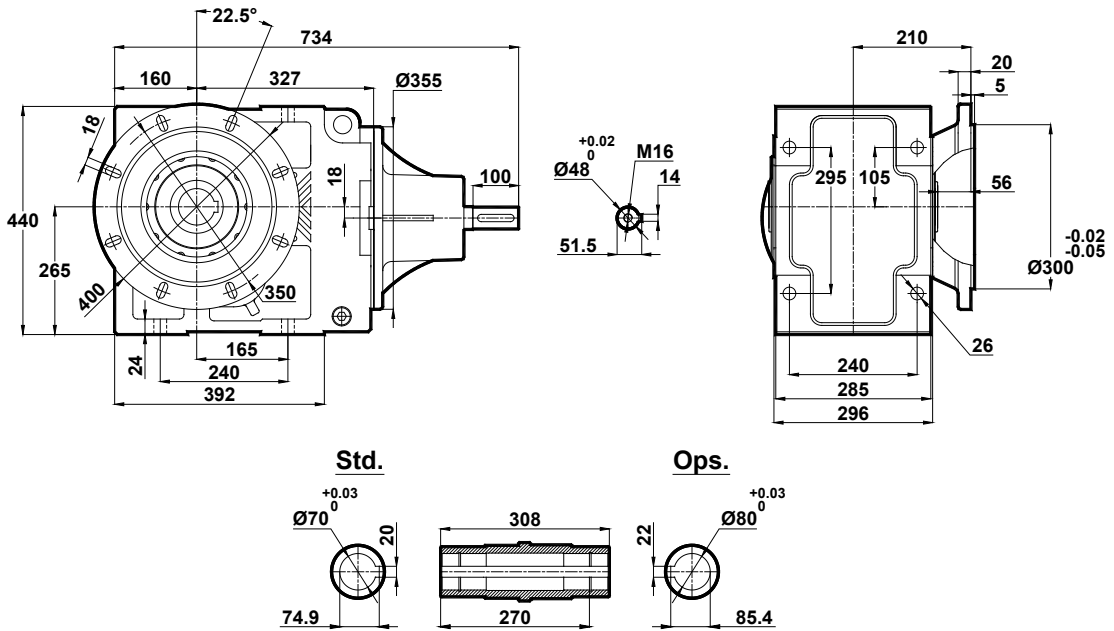

Opsiyonel flanş ölçüleri için sayfa 587'ye bakınız.
Please see on page 587 for optional flange dimensions
Siehe Seite 587 für auswählbare Flanschabmessungen

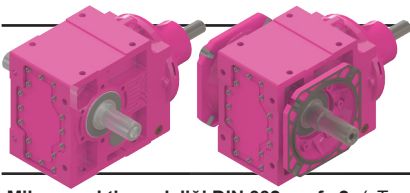

Ölçü Sayfaları Dimension Pages Abmessungenseiten

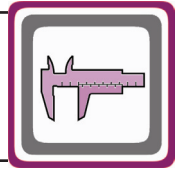

-Mil ucu çekirme deliği DIN 332 sayfa 2 / Tapped center hole to DIN 332, sheet 2 / Zentrierung mit Gewinde DIN 332, Blatt 2

KT673.04

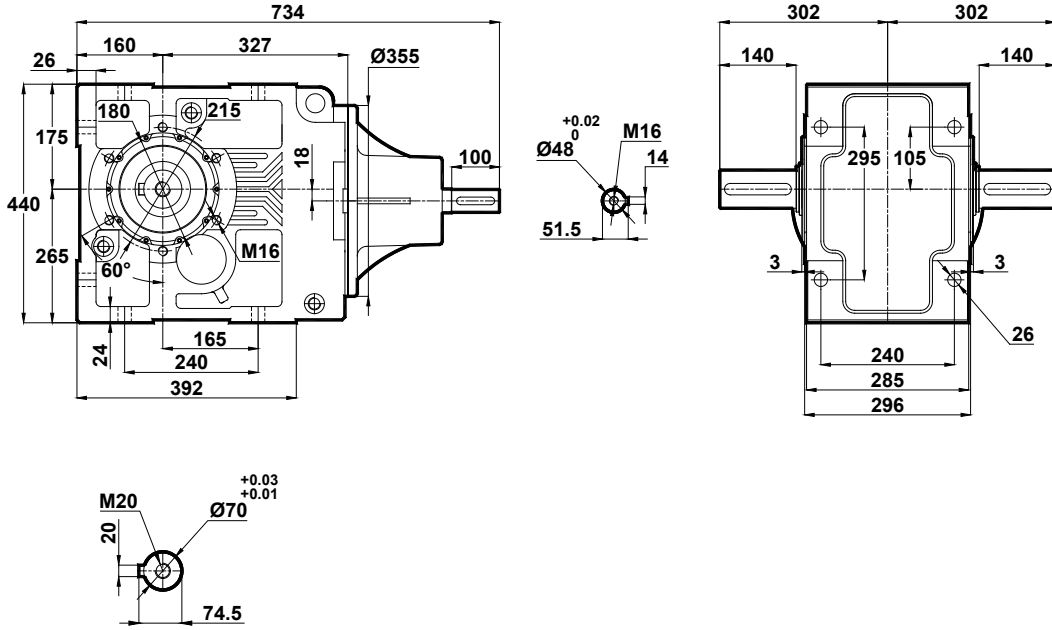

KT673.05

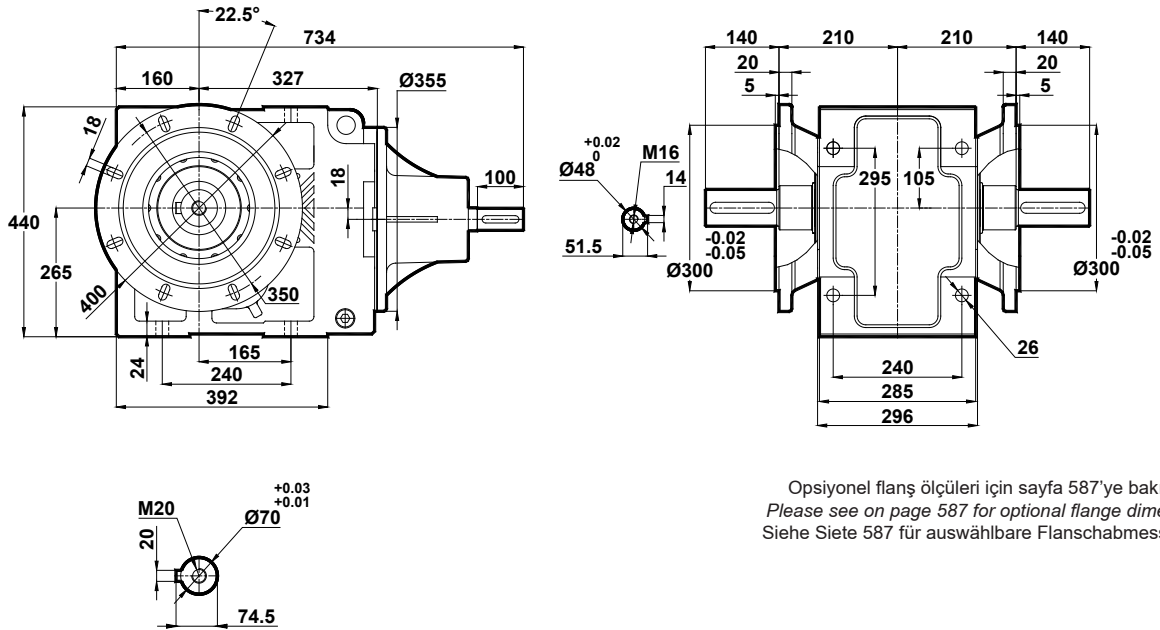

Opsiyonel flanş ölçüleri için sayfa 587'ye bakınız.
Please see on page 587 for optional flange dimensions
Siehe Seite 587 für auswählbare Flanschabmessungen



Ölçü Sayfaları Dimension Pages Abmessungenseiten



-Mil ucu çektirme deliği DIN 332 sayfa 2 / Tapped center hole to DIN 332, sheet 2 / Zentrierung mit Gewinde DIN 332, Blatt 2

KT673.08

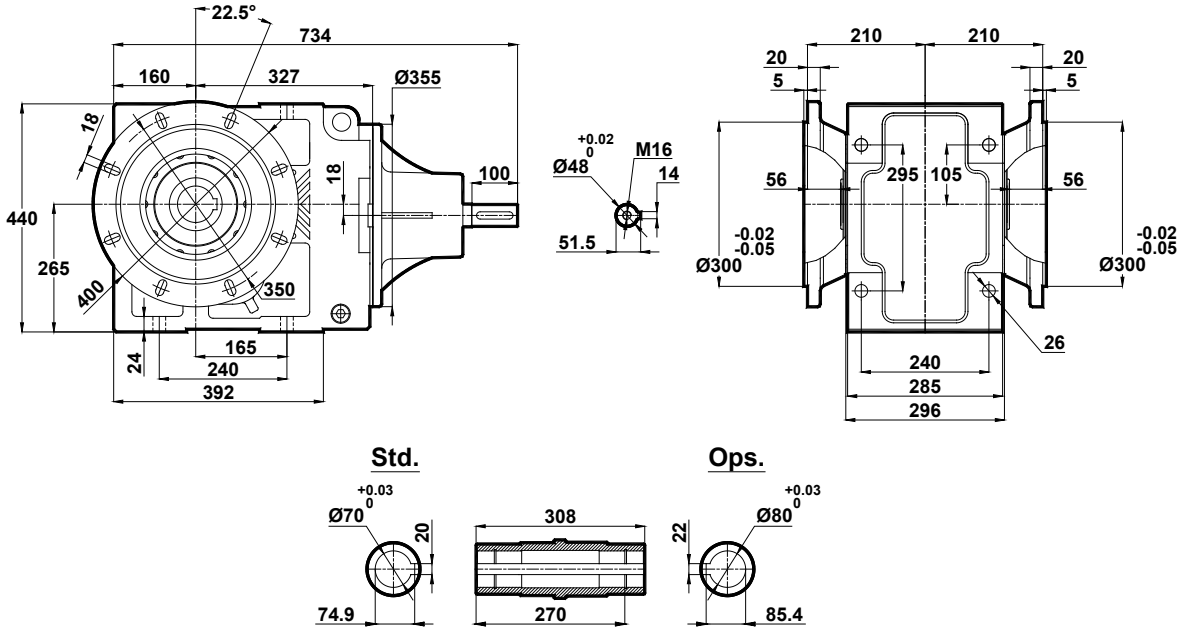

Opsiyonel flanş ölçüleri için sayfa 587'ye bakınız.
Please see on page 587 for optional flange dimensions
Siehe Seite 587 für auswählbare Flanschabmessungen

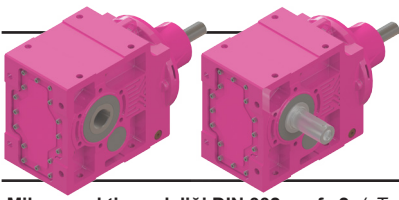

Ölçü Sayfaları

Dimension Pages

Abmessungsseiten

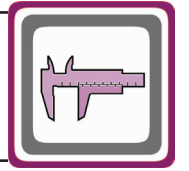

-Mil ucu çekirme deliği DIN 332 sayfa 2 / Tapped center hole to DIN 332, sheet 2 / Zentrierung mit Gewinde DIN 332, Blatt 2

KT674.00

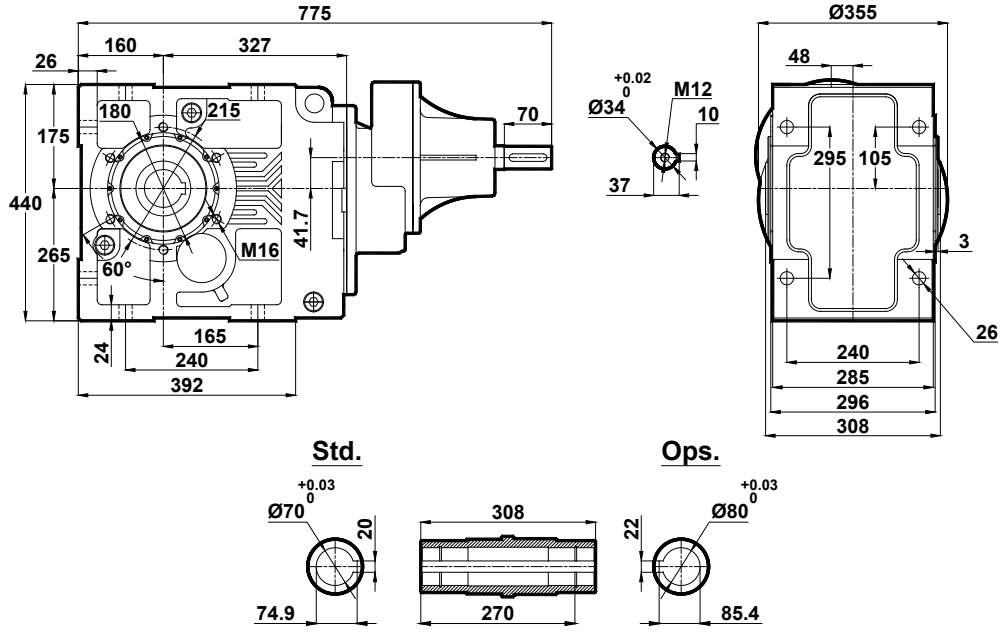

KT674.01

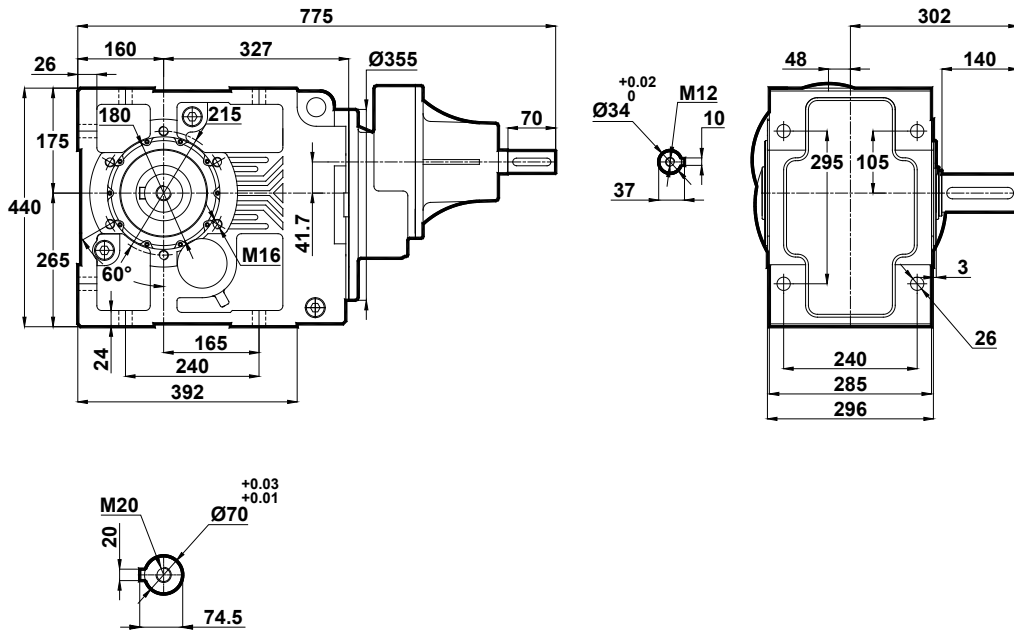

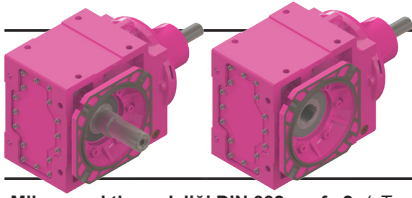

Ölçü Sayfaları Dimension Pages Abmessungenseiten



-Mil ucu çekirme deliği DIN 332 sayfa 2 / Tapped center hole to DIN 332, sheet 2 / Zentrierung mit Gewinde DIN 332, Blatt 2

KT674.02

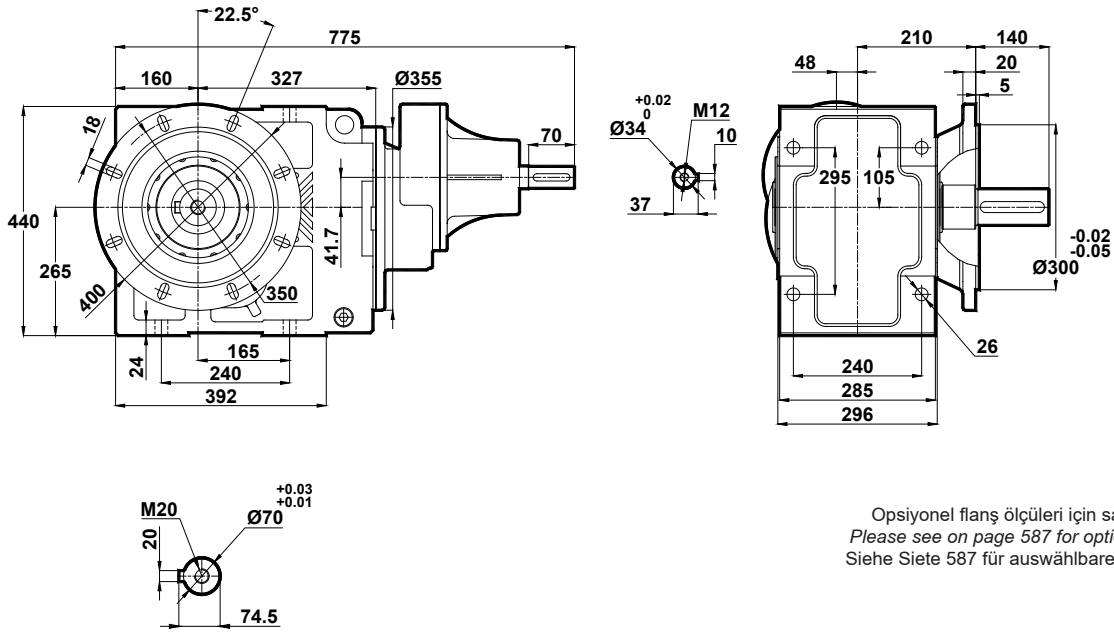

Opsiyonel flanş ölçüleri için sayfa 587'ye bakınız.
Please see on page 587 for optional flange dimensions
Siehe Seite 587 für auswählbare Flanschabmessungen

KT674.03

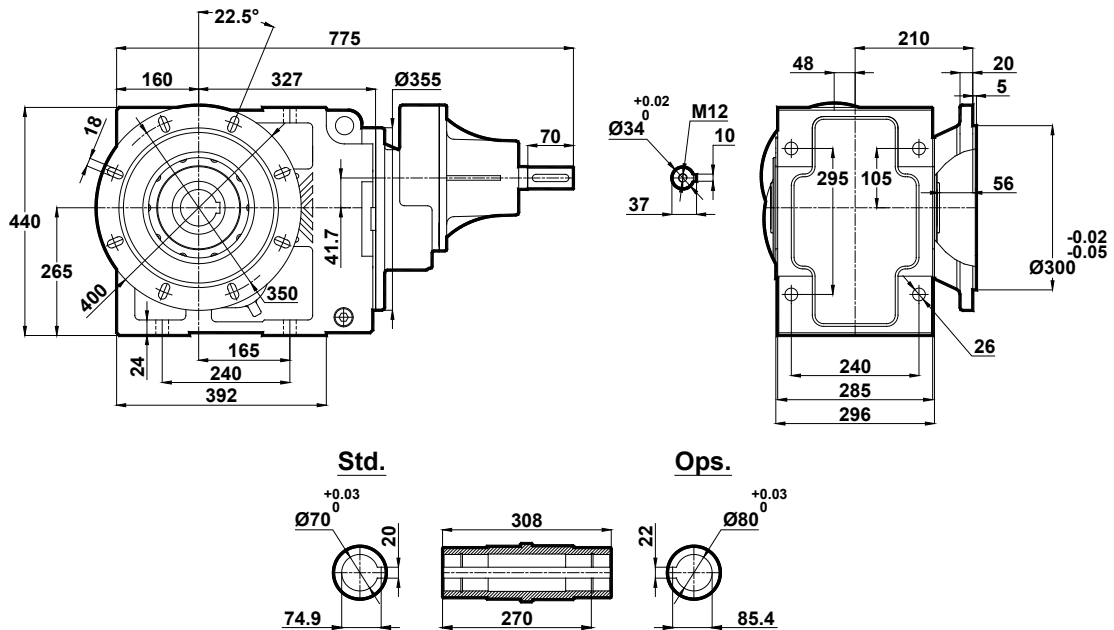

Std.

Ops.

Opsiyonel flanş ölçüleri için sayfa 587'ye bakınız.
Please see on page 587 for optional flange dimensions
Siehe Seite 587 für auswählbare Flanschabmessungen

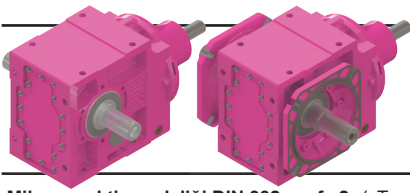

Ölçü Sayfaları Dimension Pages Abmessungenseiten

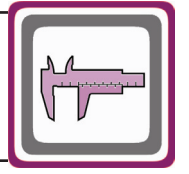

-Mil ucu çektirme deliği DIN 332 sayfa 2 / Tapped center hole to DIN 332, sheet 2 / Zentrierung mit Gewinde DIN 332, Blatt 2

KT674.04

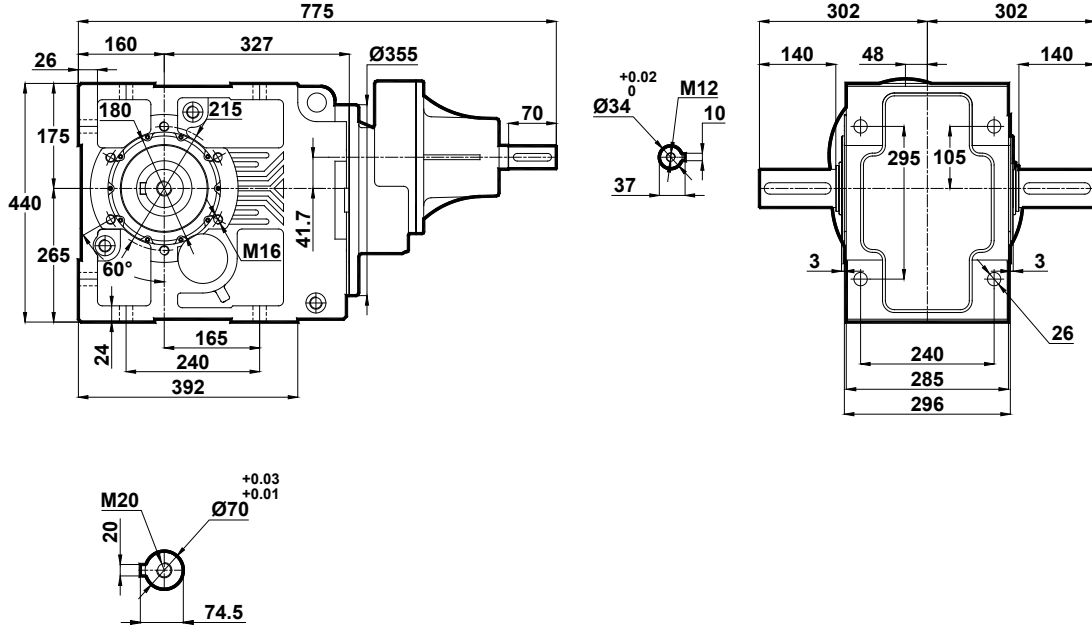

KT674.05

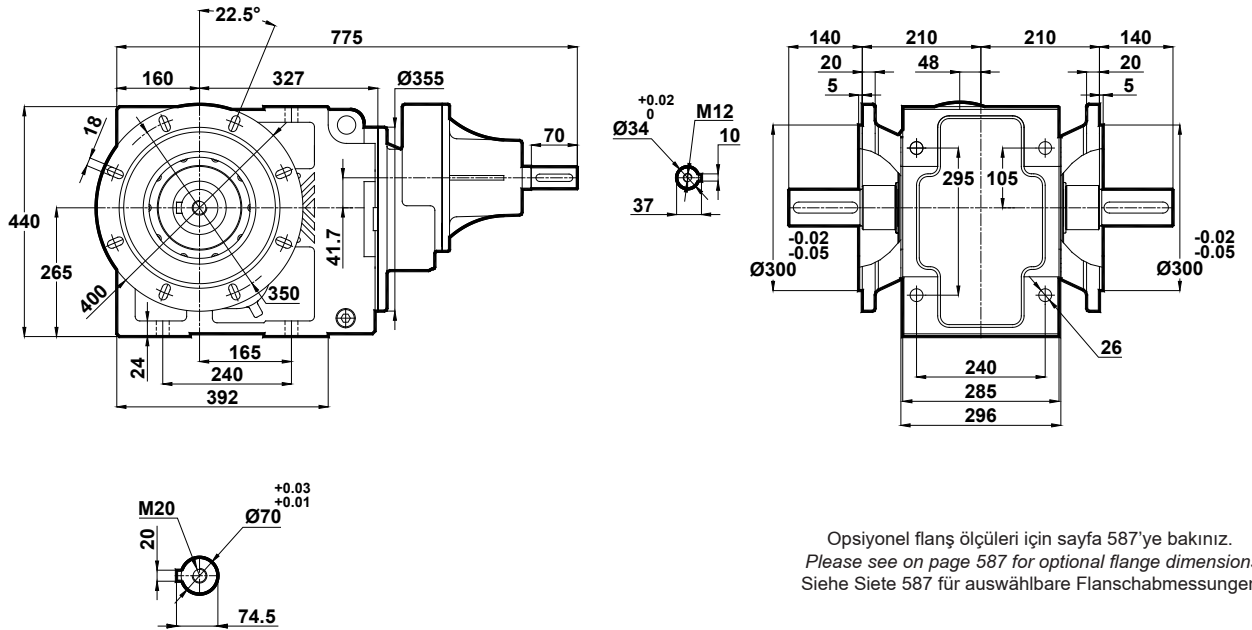

Opsiyonel flanş ölçüleri için sayfa 587'ye bakınız.
Please see on page 587 for optional flange dimensions
Siehe Seite 587 für auswählbare Flanschabmessungen



Ölçü Sayfaları Dimension Pages Abmessungenseiten



-Mil ucu çekirme deliği DIN 332 sayfa 2 / Tapped center hole to DIN 332, sheet 2 / Zentrierung mit Gewinde DIN 332, Blatt 2

KT674.08

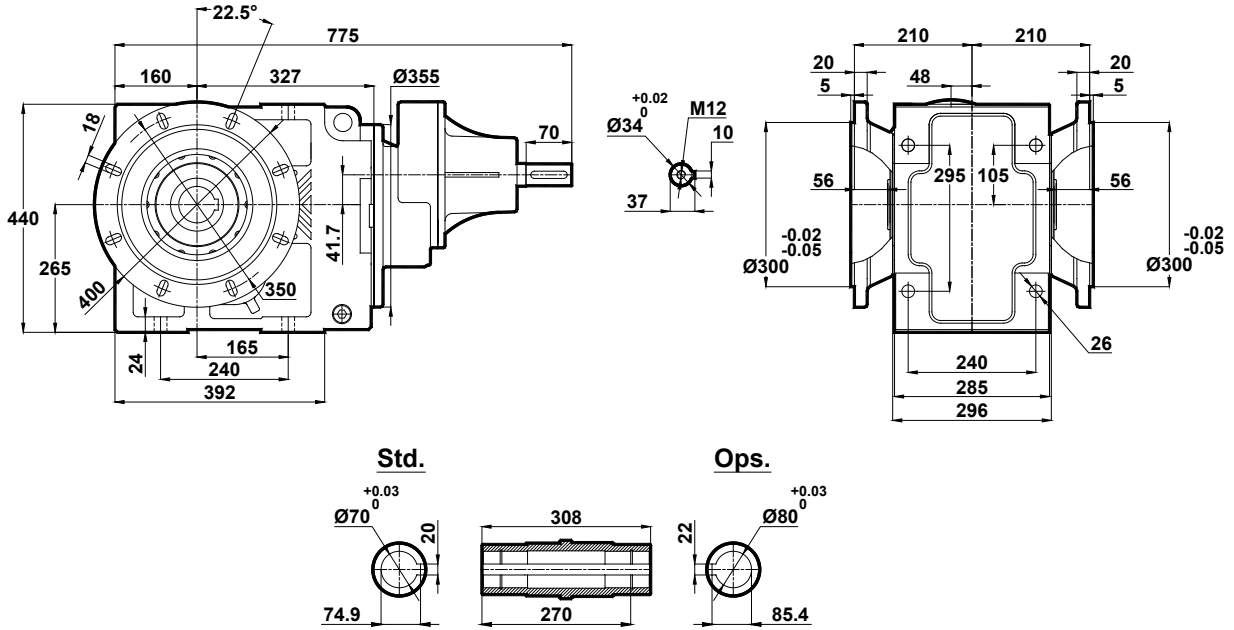

Opsiyonel flanş ölçüleri için sayfa 587'ye bakınız.
Please see on page 587 for optional flange dimensions
Siehe Seite 587 für auswählbare Flanschabmessungen



Ölçü Sayfaları

Dimension Pages

Abmessungenseiten

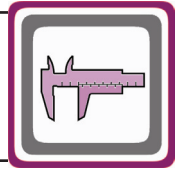

-Mil ucu çekirme deliği DIN 332 sayfa 2 / Tapped center hole to DIN 332, sheet 2 / Zentrierung mit Gewinde DIN 332, Blatt 2

KT675.00
KT676.00

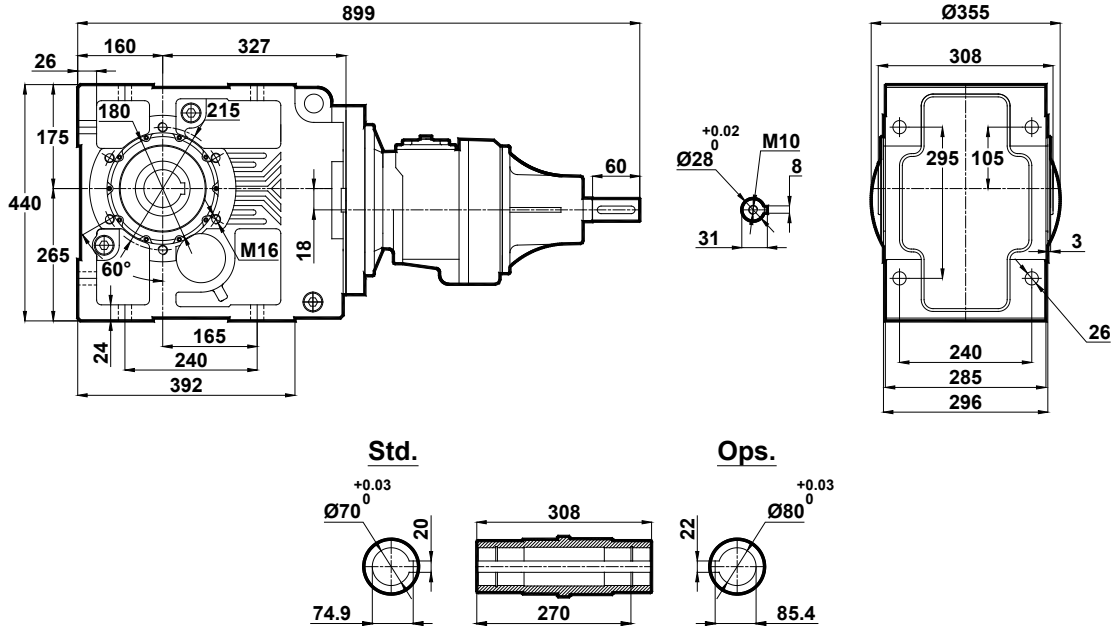

KT675.01
KT676.01

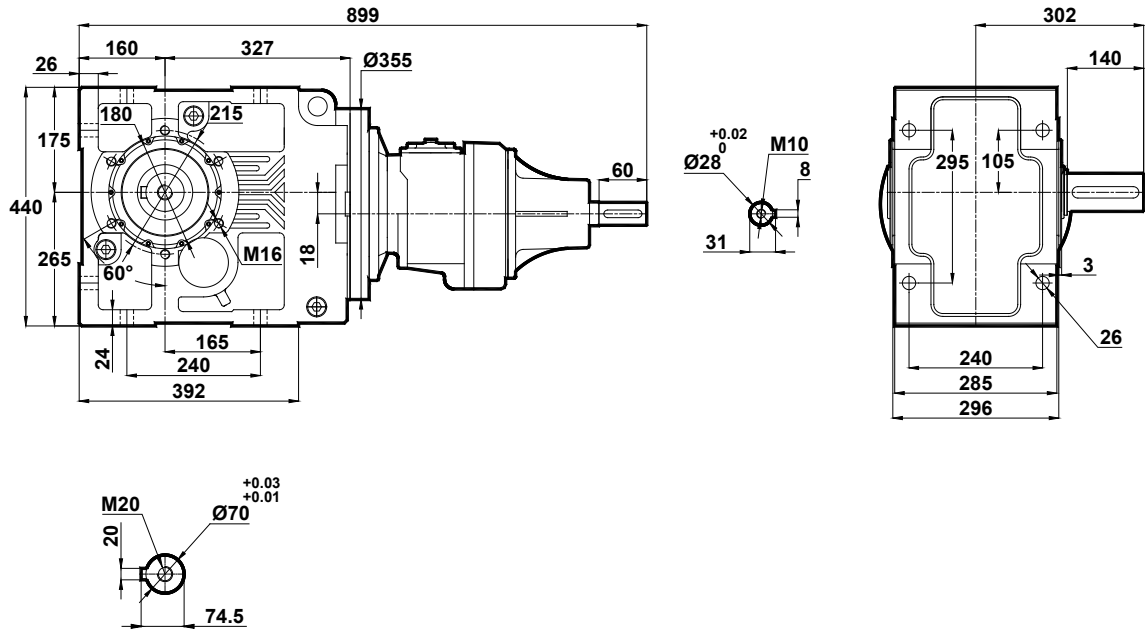

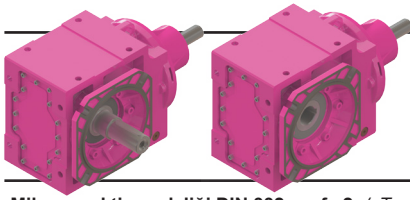

Ölçü Sayfaları Dimension Pages Abmessungsseiten



-Mil ucu çektirme deliği DIN 332 sayfa 2 / Tapped center hole to DIN 332, sheet 2 / Zentrierung mit Gewinde DIN 332, Blatt 2

KT675.02
KT676.02

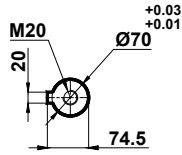
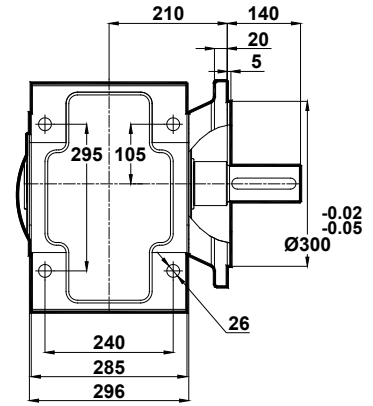
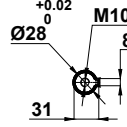
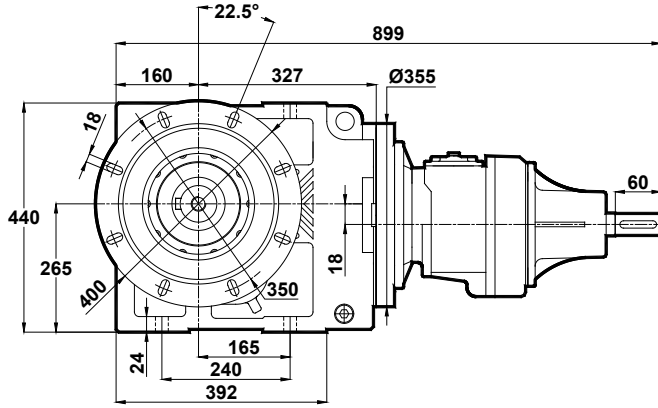

Opsiyonel flanş ölçüleri için sayfa 587'ye bakınız.
Please see on page 587 for optional flange dimensions
Siehe Seite 587 für auswählbare Flanschabmessungen

KT675.03
KT676.03

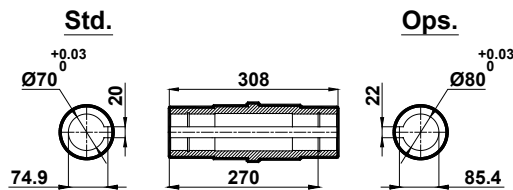
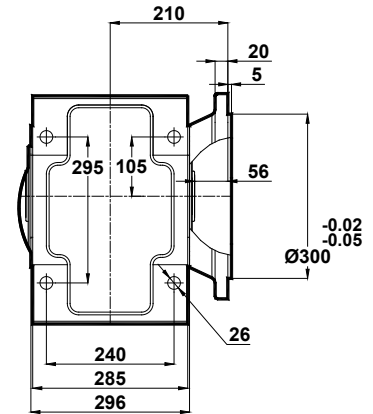
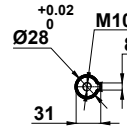
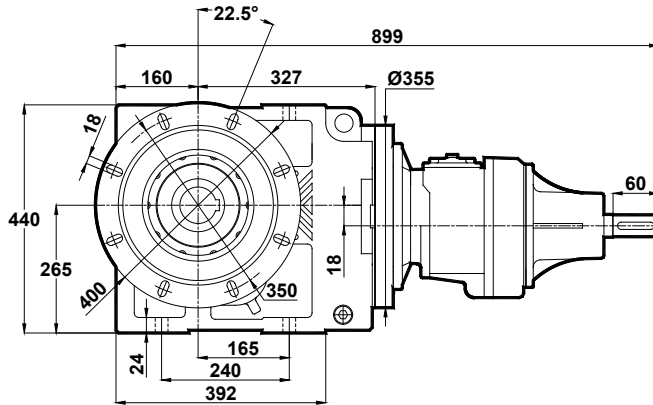

Opsiyonel flanş ölçüleri için sayfa 587'ye bakınız.
Please see on page 587 for optional flange dimensions
Siehe Seite 587 für auswählbare Flanschabmessungen

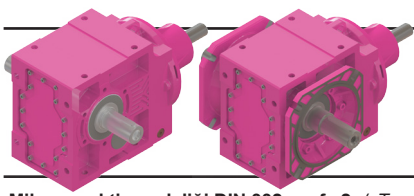

Ölçü Sayfaları Dimension Pages Abmessungenseiten

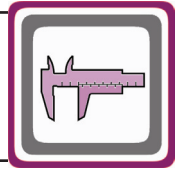

-Mil ucu çekirme deliği DIN 332 sayfa 2 / Tapped center hole to DIN 332, sheet 2 / Zentrierung mit Gewinde DIN 332, Blatt 2

KT675.04
KT676.04

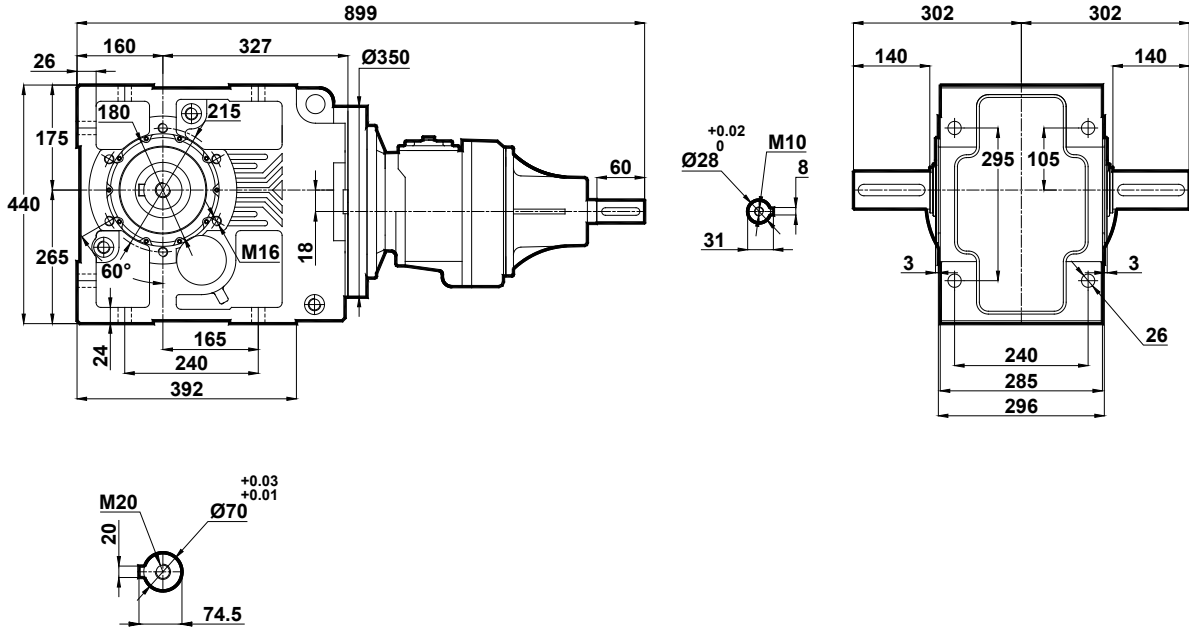

KT675.05
KT676.05

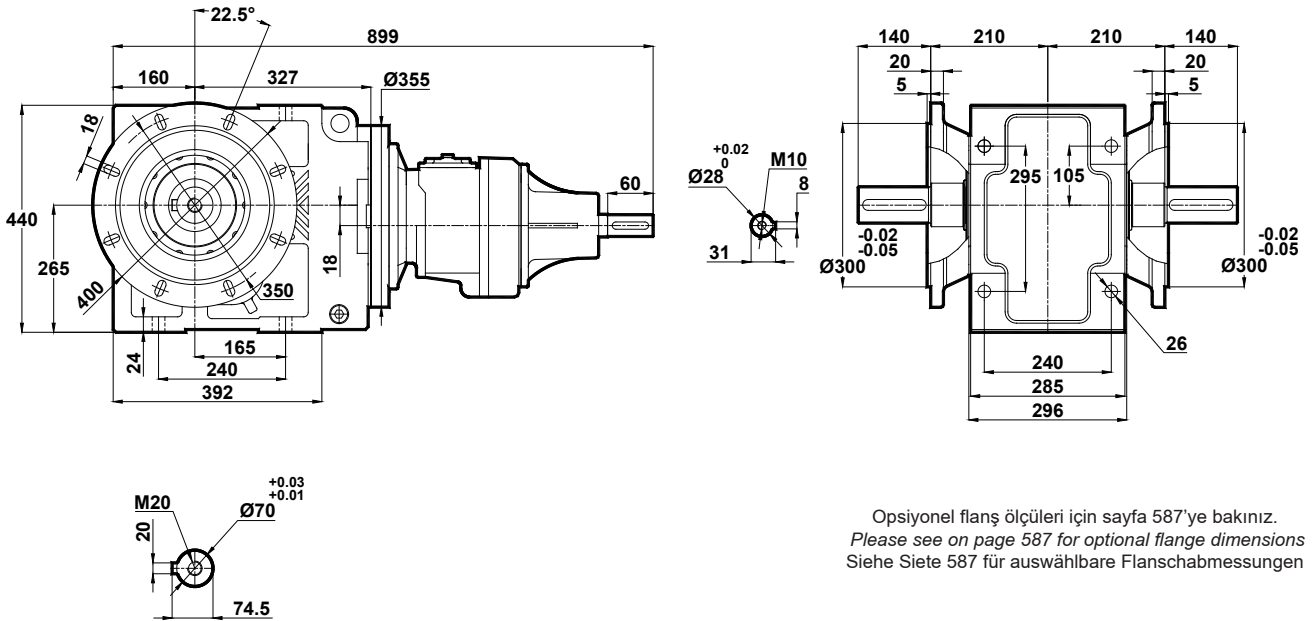

Opsiyonel flanş ölçüleri için sayfa 587'ye bakınız.
Please see on page 587 for optional flange dimensions
Siehe Seite 587 für auswählbare Flanschabmessungen



Ölçü Sayfaları Dimension Pages Abmessungenseiten

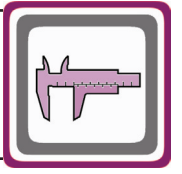

-Mil ucu çekirme deliği DIN 332 sayfa 2 / Tapped center hole to DIN 332, sheet 2 / Zentrierung mit Gewinde DIN 332, Blatt 2

KT675.08
KT676.08

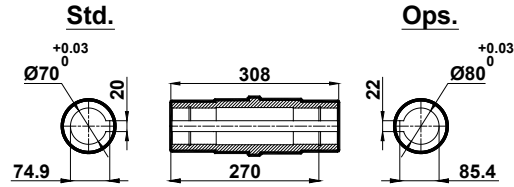
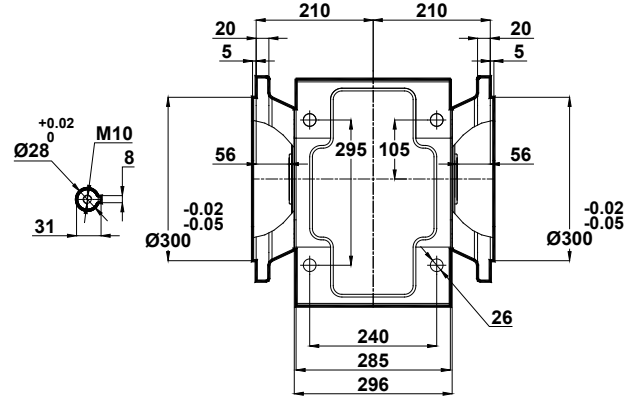
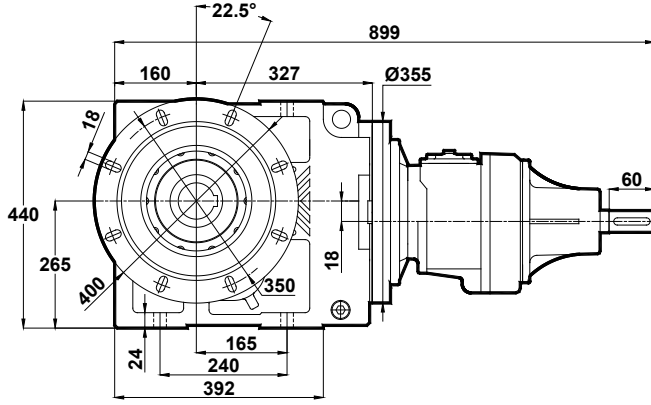

Opsiyonel flanş ölçüleri için sayfa 587'ye bakınız.
Please see on page 587 for optional flange dimensions
Siehe Seite 587 für auswählbare Flanschabmessungen



Ölçü Sayfaları

Dimension Pages

Abmessungsseiten

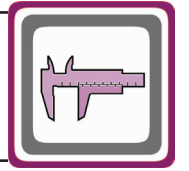

-Mil ucu çektirme deliği DIN 332 sayfa 2 / Tapped center hole to DIN 332, sheet 2 / Zentrierung mit Gewinde DIN 332, Blatt 2

KT773.00

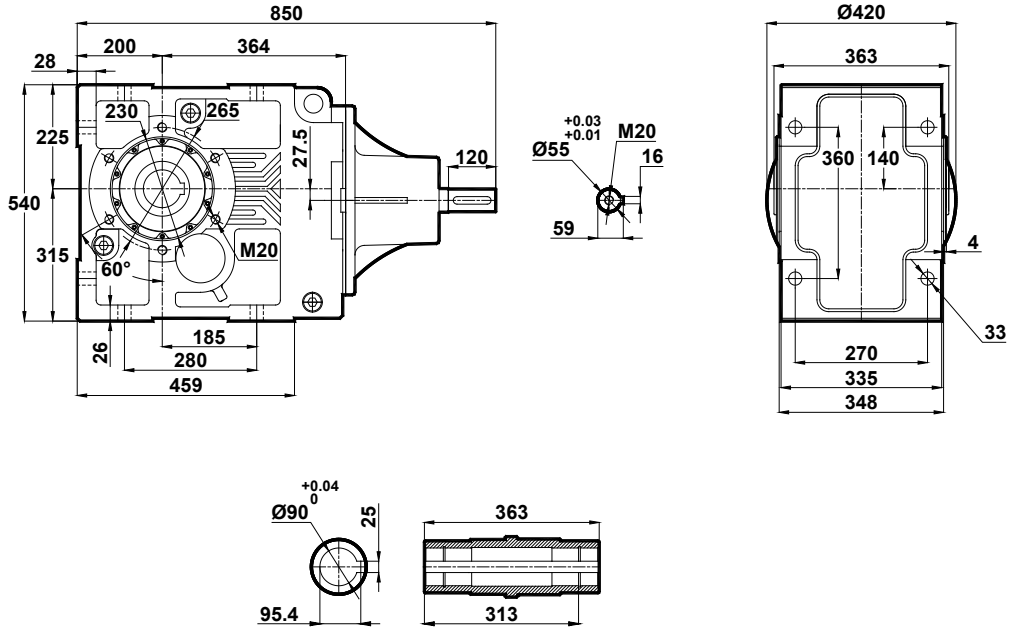

KT773.01

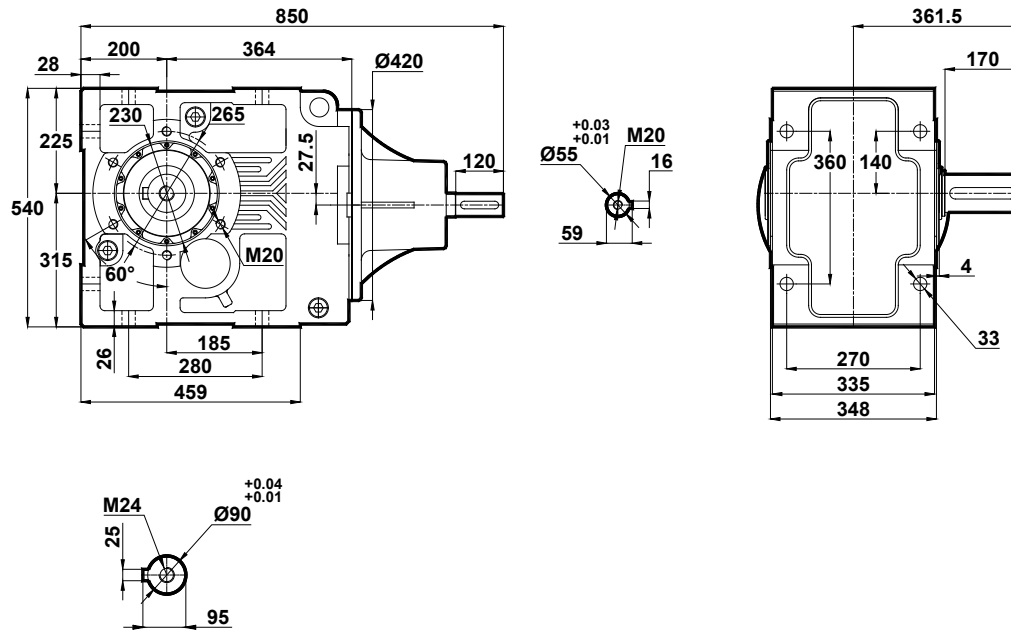



Ölçü Sayfaları Dimension Pages Abmessungenseiten



-Mil ucu çekirme deliği DIN 332 sayfa 2 / Tapped center hole to DIN 332, sheet 2 / Zentrierung mit Gewinde DIN 332, Blatt 2

KT773.02

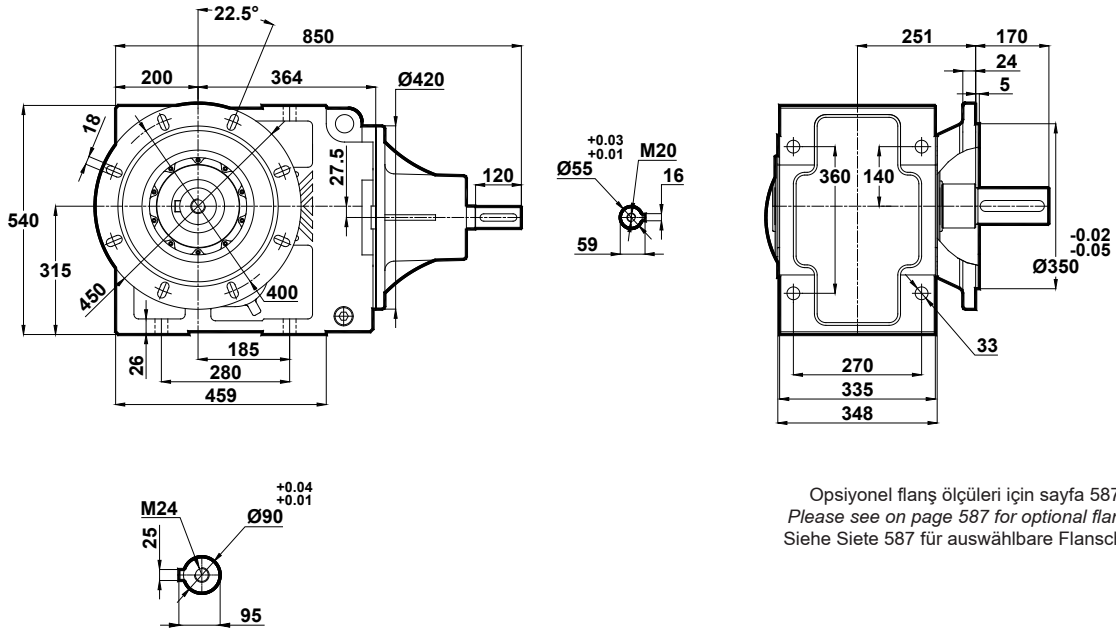

Opsiyonel flanş ölçüleri için sayfa 587'ye bakınız.
Please see on page 587 for optional flange dimensions
Siehe Seite 587 für auswählbare Flanschabmessungen

KT773.03

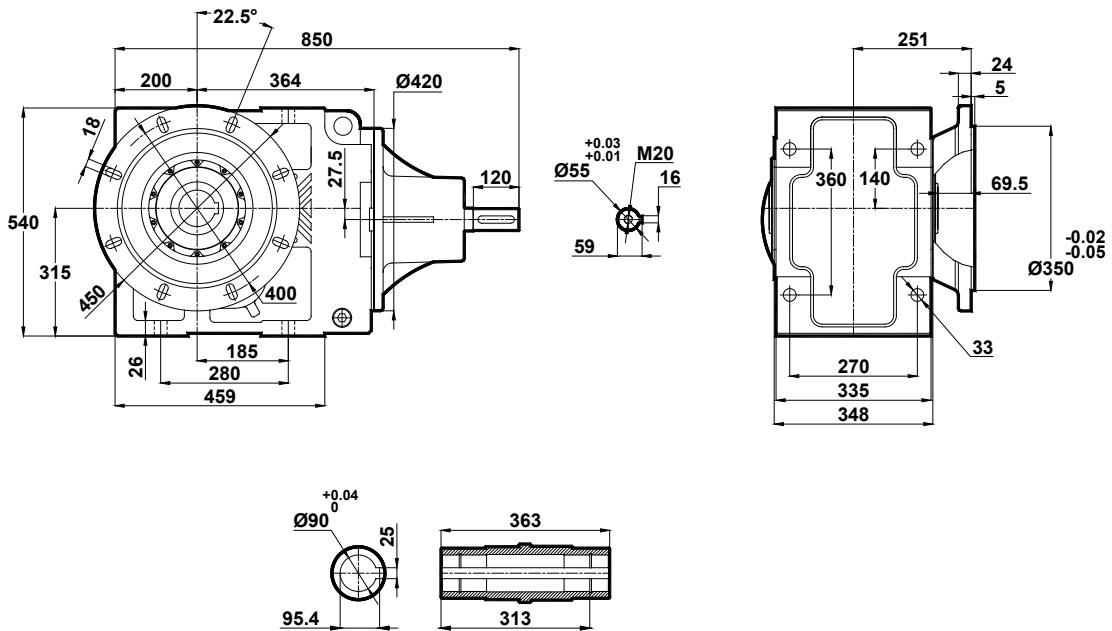

Opsiyonel flanş ölçüleri için sayfa 587'ye bakınız.
Please see on page 587 for optional flange dimensions
Siehe Seite 587 für auswählbare Flanschabmessungen

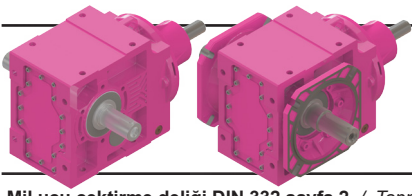

Ölçü Sayfaları Dimension Pages Abmessungenseiten

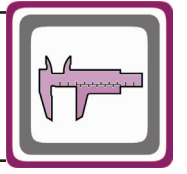

-Mil ucu çekirme deliği DIN 332 sayfa 2 / Tapped center hole to DIN 332, sheet 2 / Zentrierung mit Gewinde DIN 332, Blatt 2

KT773.04

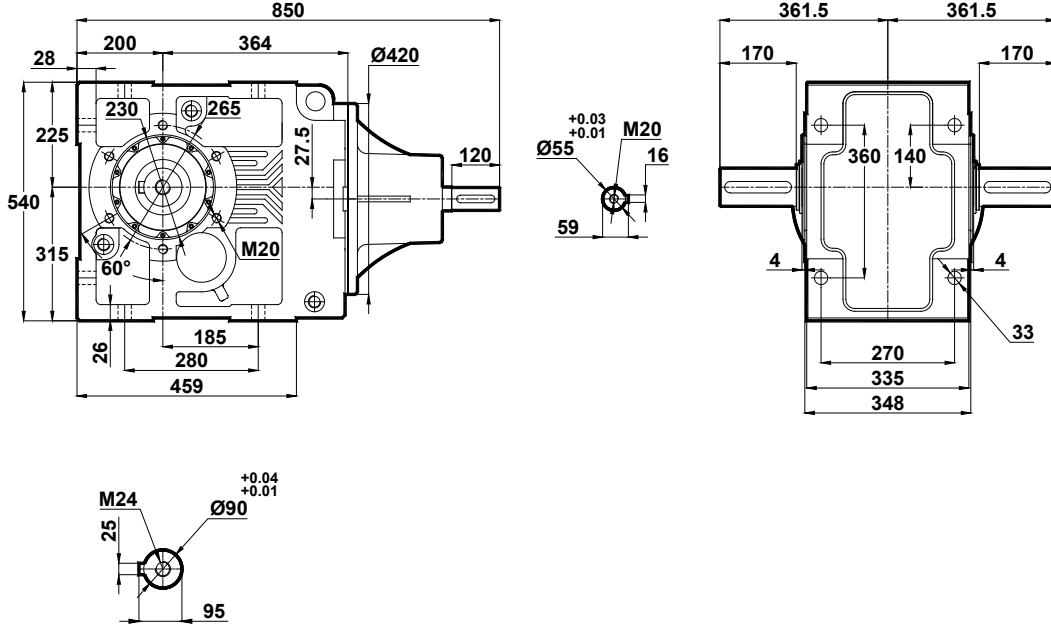

KT773.05

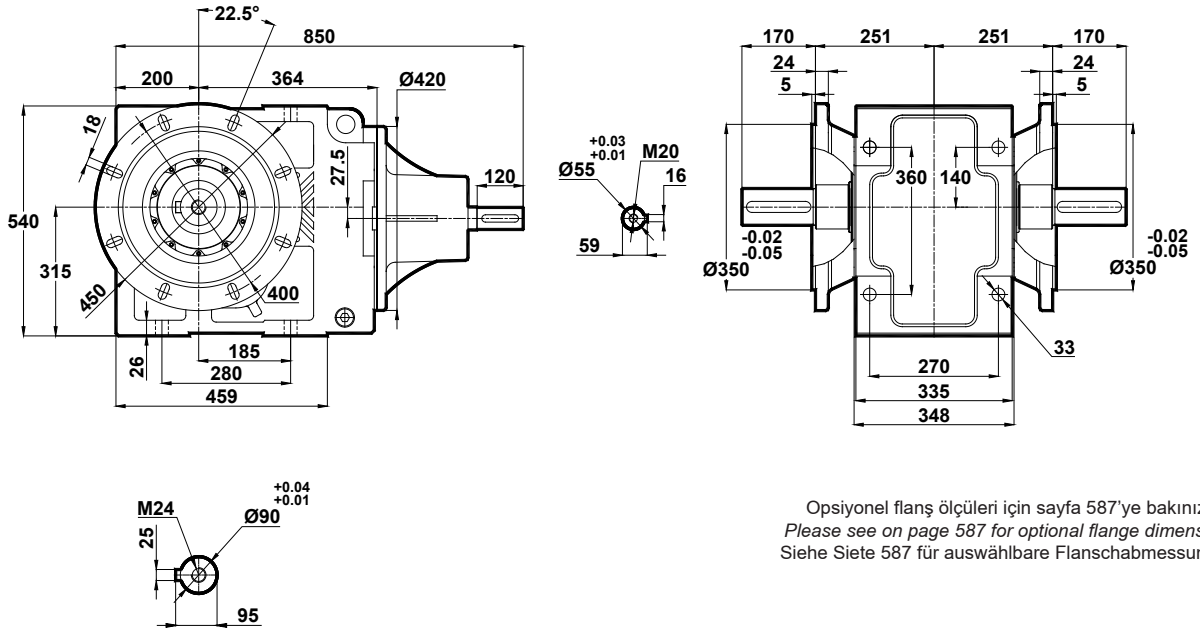

Opsiyonel flanş ölçüleri için sayfa 587'ye bakınız.
Please see on page 587 for optional flange dimensions
Siehe Seite 587 für auswählbare Flanschabmessungen



Ölçü Sayfaları Dimension Pages Abmessungenseiten



-Mil ucu çektirme deliği DIN 332 sayfa 2 / Tapped center hole to DIN 332, sheet 2 / Zentrierung mit Gewinde DIN 332, Blatt 2

KT773.08

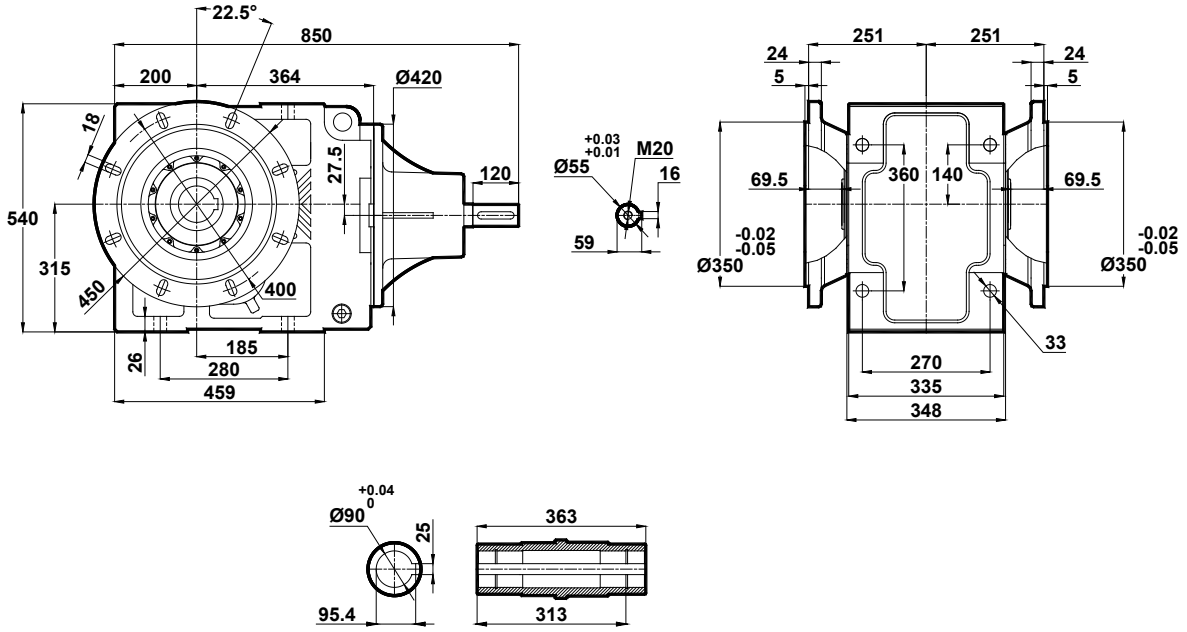

Opsiyonel flanş ölçüleri için sayfa 587'ye bakınız.
Please see on page 587 for optional flange dimensions
Siehe Seite 587 für auswählbare Flanschabmessungen



Ölçü Sayfaları

Dimension Pages

Abmessungsseiten

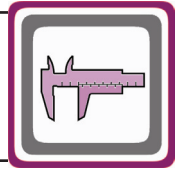

-Mil ucu çekirme deliği DIN 332 sayfa 2 / Tapped center hole to DIN 332, sheet 2 / Zentrierung mit Gewinde DIN 332, Blatt 2

KT774.00

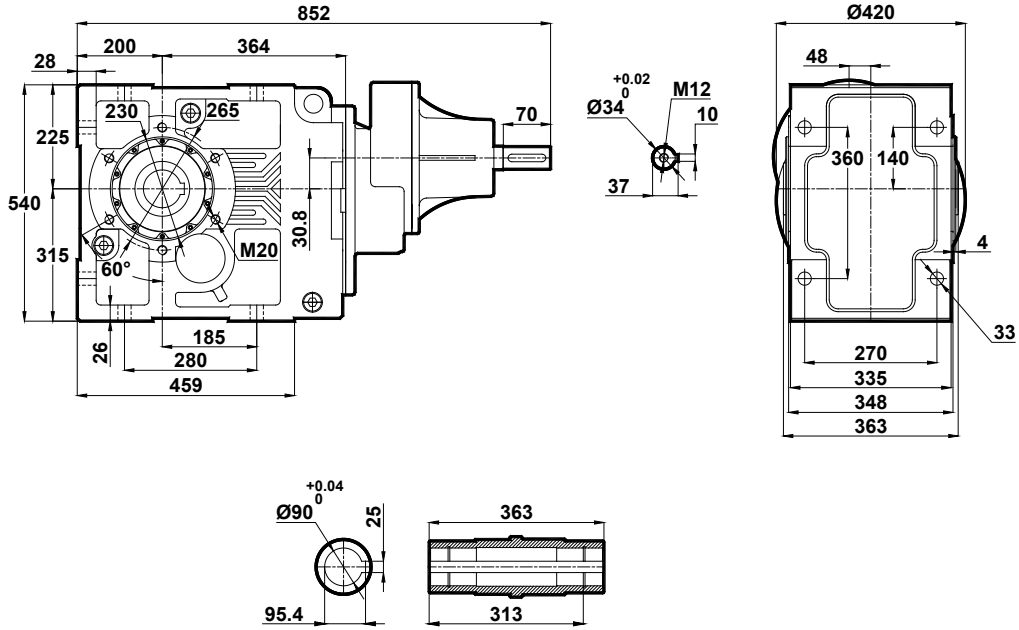

KT774.01

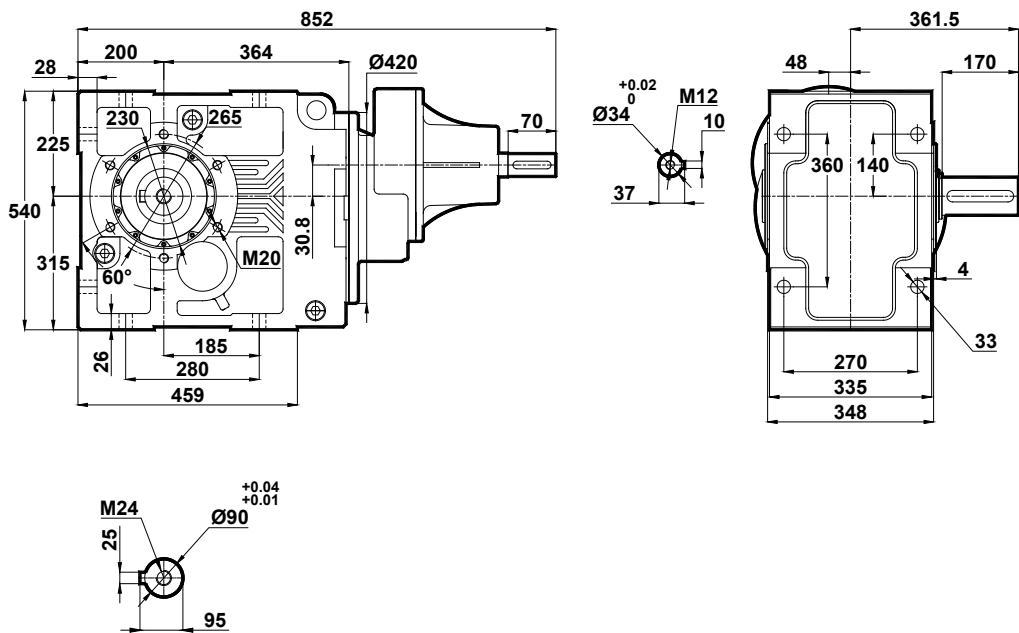



Ölçü Sayfaları Dimension Pages Abmessungenseiten



-Mil ucu çekirme deliği DIN 332 sayfa 2 / Tapped center hole to DIN 332, sheet 2 / Zentrierung mit Gewinde DIN 332, Blatt 2

KT774.02

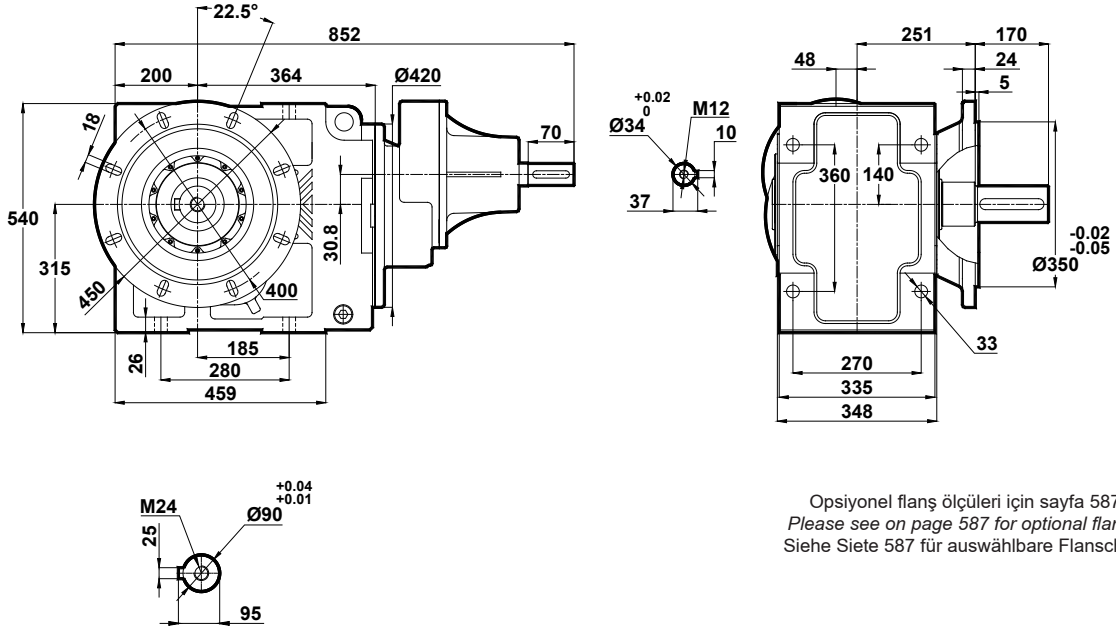

Opsiyonel flanş ölçüleri için sayfa 587'ye bakınız.
Please see on page 587 for optional flange dimensions
Siehe Seite 587 für auswählbare Flanschabmessungen

KT774.03

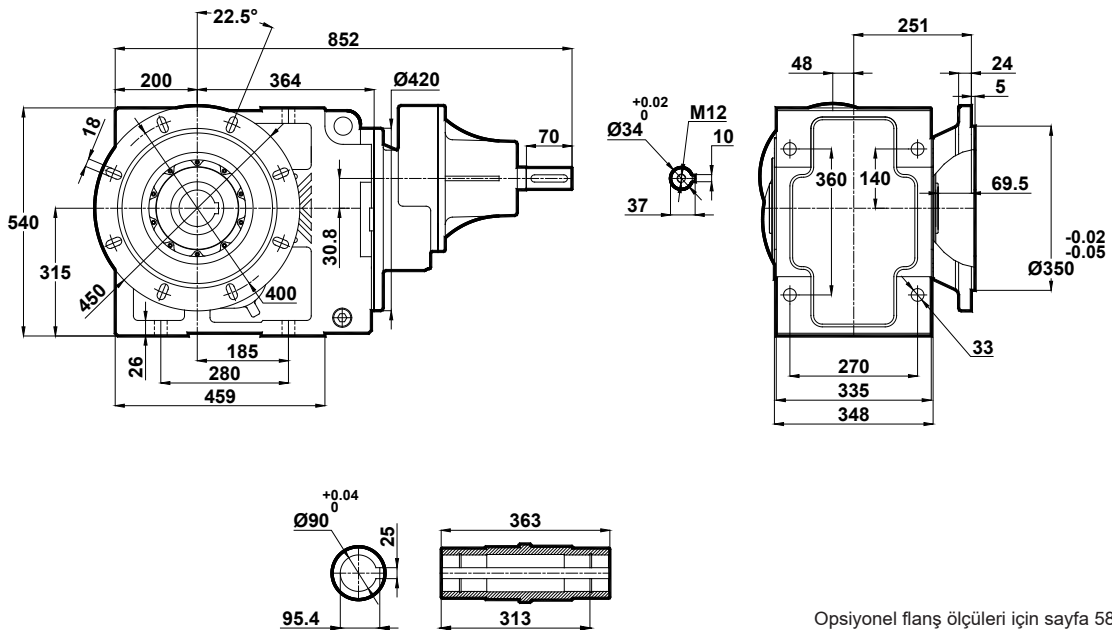

Opsiyonel flanş ölçüleri için sayfa 587'ye bakınız.
Please see on page 587 for optional flange dimensions
Siehe Seite 587 für auswählbare Flanschabmessungen

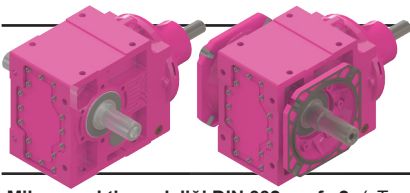

Ölçü Sayfaları Dimension Pages Abmessungsseiten

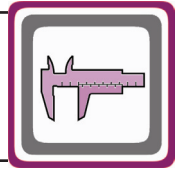

-Mil ucu çektirme deliği DIN 332 sayfa 2 / Tapped center hole to DIN 332, sheet 2 / Zentrierung mit Gewinde DIN 332, Blatt 2

KT774.04

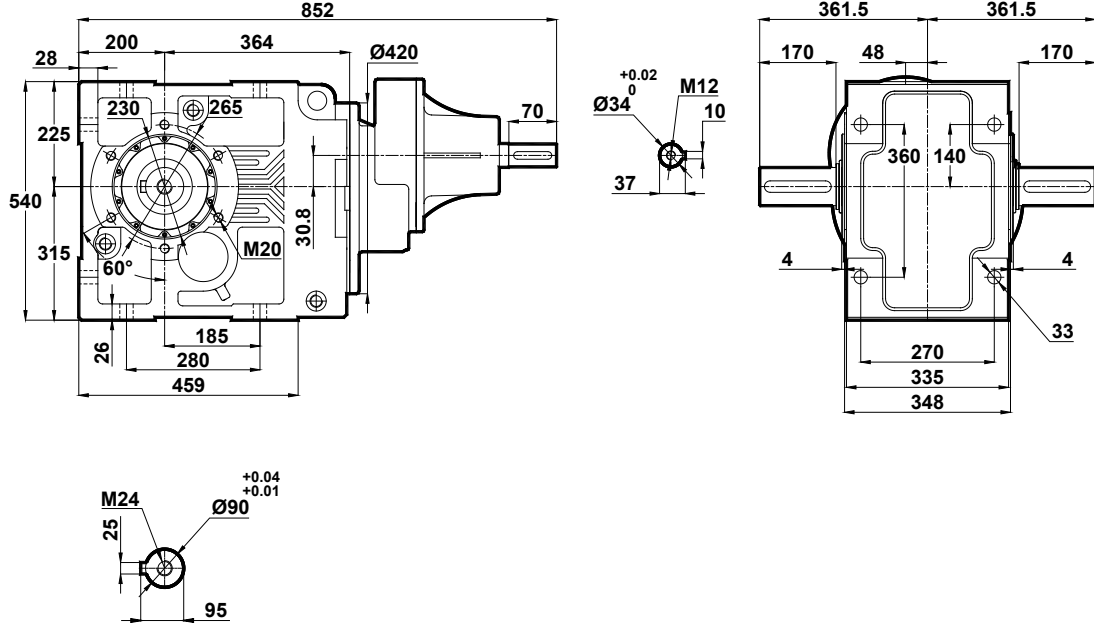

KT774.05

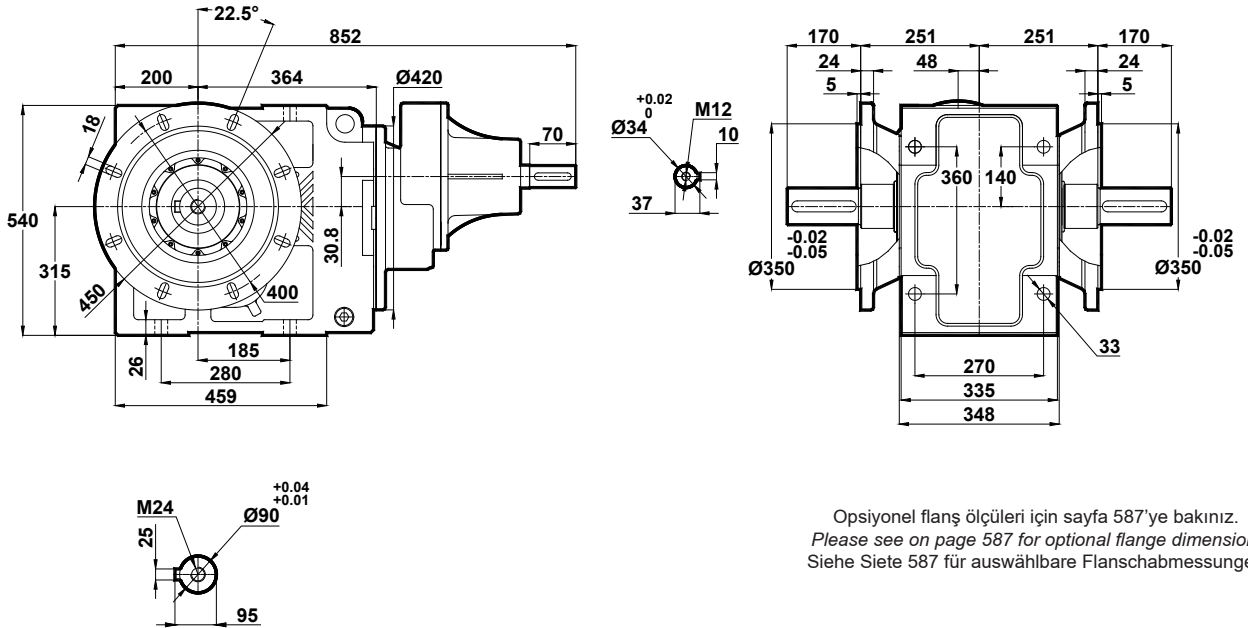

Opsiyonel flanş ölçüleri için sayfa 587'ye bakınız.
Please see on page 587 for optional flange dimensions
Siehe Seite 587 für auswählbare Flanschabmessungen



Ölçü Sayfaları

Dimension Pages

Abmessungsseiten



-Mil ucu çekirme deliği DIN 332 sayfa 2 / Tapped center hole to DIN 332, sheet 2 / Zentrierung mit Gewinde DIN 332, Blatt 2

KT774.08

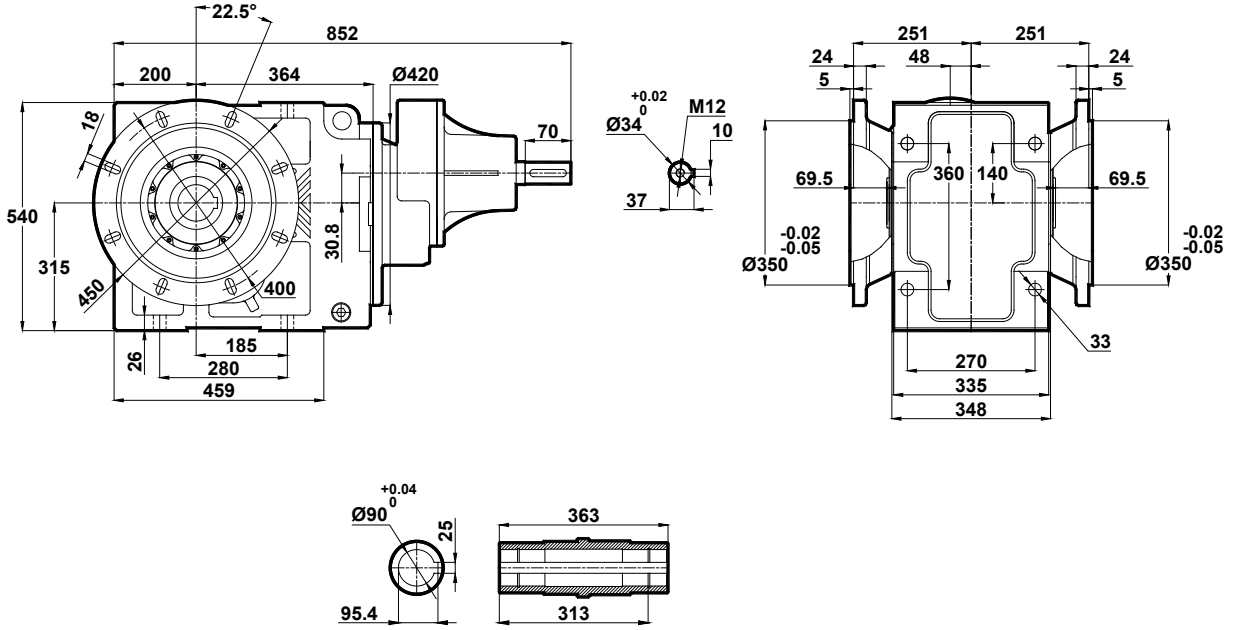

Opsiyonel flanş ölçüleri için sayfa 587'ye bakınız.
Please see on page 587 for optional flange dimensions
Siehe Seite 587 für auswählbare Flanschabmessungen



Ölçü Sayfaları

Dimension Pages

Abmessungsseiten

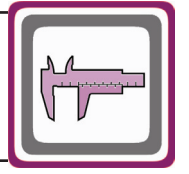

-Mil ucu çekirme deliği DIN 332 sayfa 2 / Tapped center hole to DIN 332, sheet 2 / Zentrierung mit Gewinde DIN 332, Blatt 2

KT775.00
KT776.00

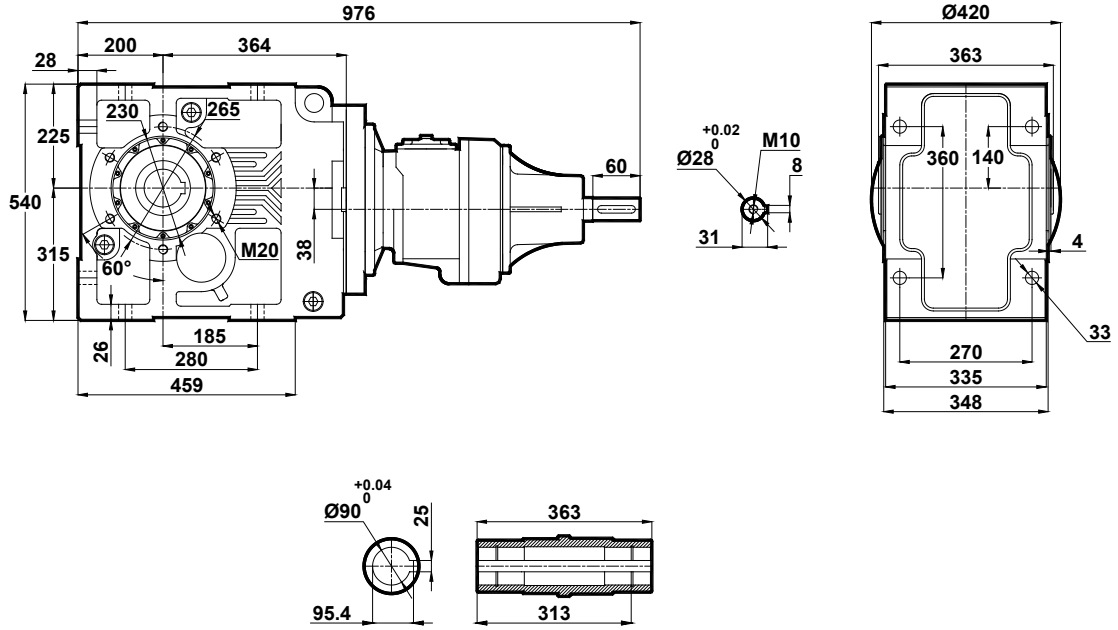

KT775.01
KT776.01

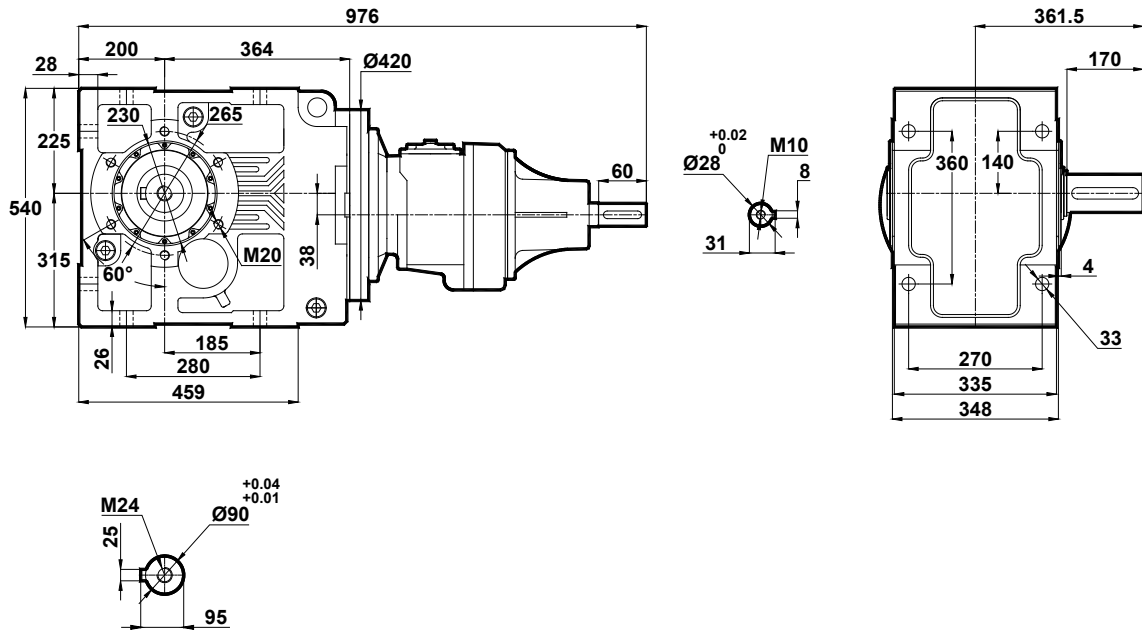

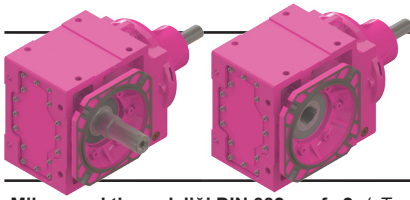

Ölçü Sayfaları

Dimension Pages

Abmessungsseiten



-Mil ucu çekirme deliği DIN 332 sayfa 2 / Tapped center hole to DIN 332, sheet 2 / Zentrierung mit Gewinde DIN 332, Blatt 2

KT775.02
KT776.02

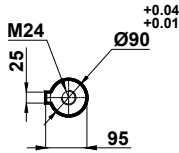
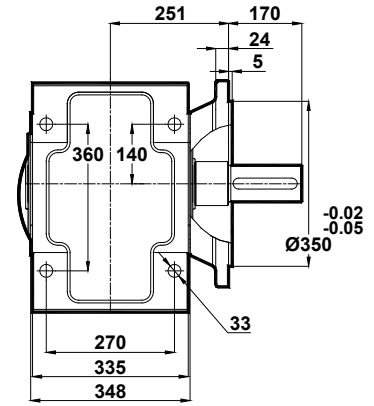
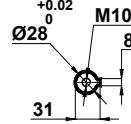
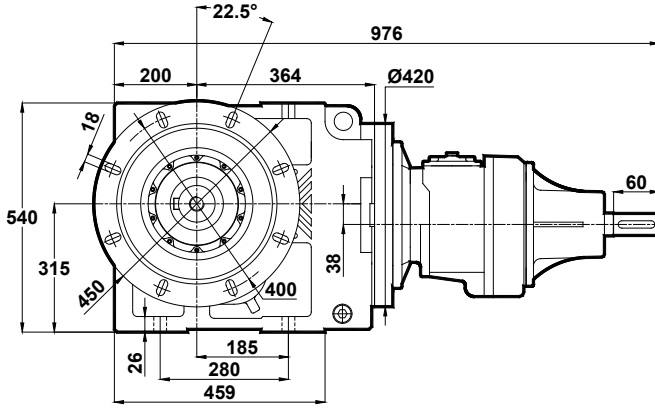

Opsiyonel flanş ölçüleri için sayfa 587'ye bakınız.
Please see on page 587 for optional flange dimensions
Siehe Seite 587 für auswählbare Flanschabmessungen

KT775.03
KT776.03

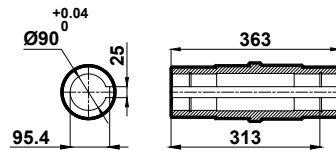
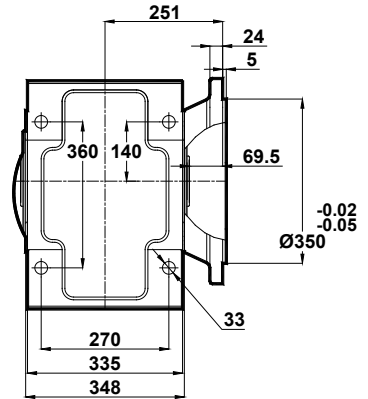
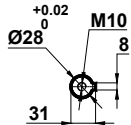
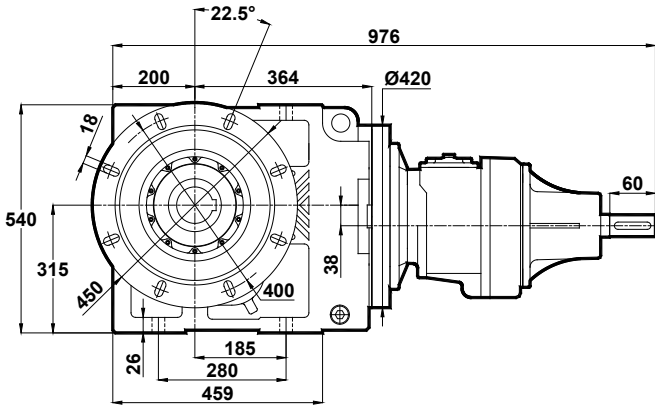

Opsiyonel flanş ölçüleri için sayfa 587'ye bakınız.
Please see on page 587 for optional flange dimensions
Siehe Seite 587 für auswählbare Flanschabmessungen

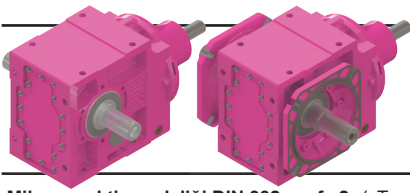

Ölçü Sayfaları Dimension Pages Abmessungsseiten

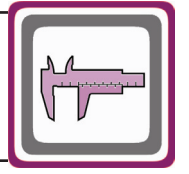

-Mil ucu çektirme deliği DIN 332 sayfa 2 / Tapped center hole to DIN 332, sheet 2 / Zentrierung mit Gewinde DIN 332, Blatt 2

KT775.04
KT776.04

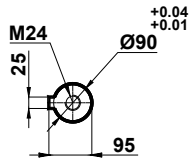
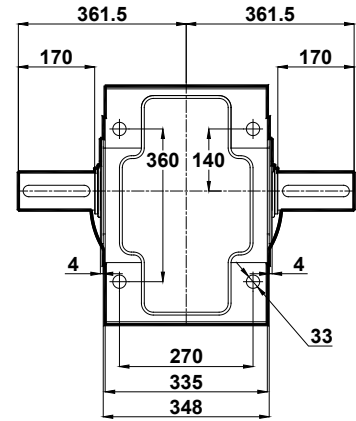
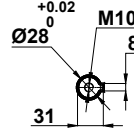
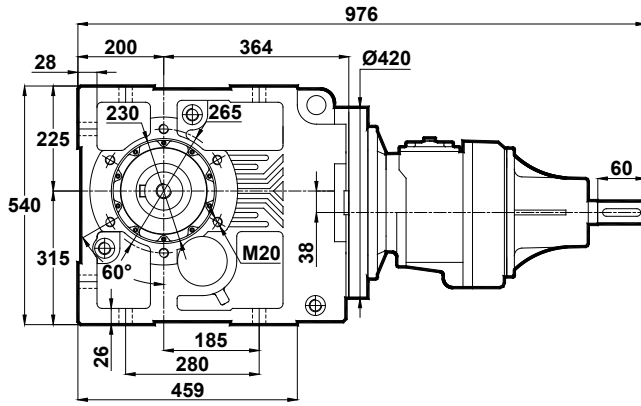

KT775.05
KT776.05

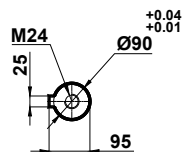
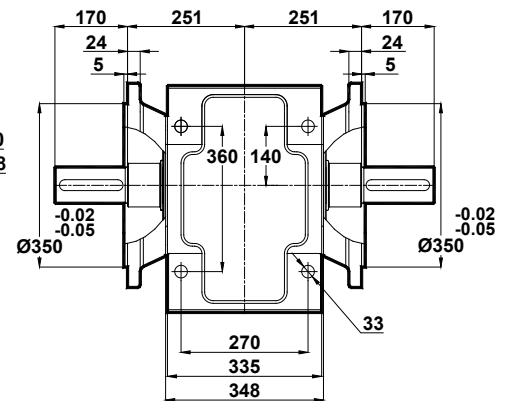
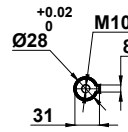
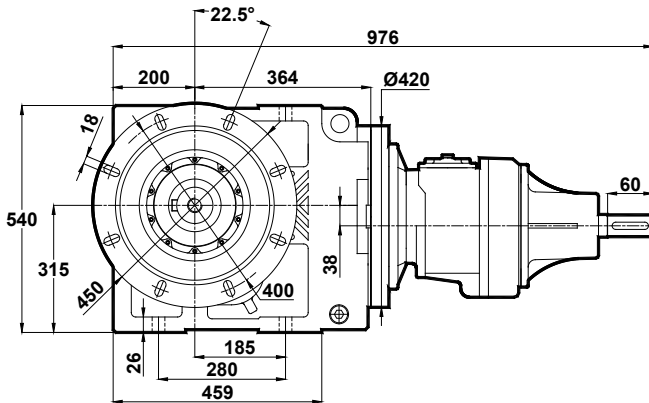

Opsiyonel flanş ölçüleri için sayfa 587'ye bakınız.
Please see on page 587 for optional flange dimensions
Siehe Seite 587 für auswählbare Flanschabmessungen



Ölçü Sayfaları Dimension Pages Abmessungsseiten

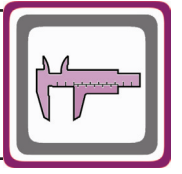

-Mil ucu çektirme deliği DIN 332 sayfa 2 / Tapped center hole to DIN 332, sheet 2 / Zentrierung mit Gewinde DIN 332, Blatt 2

KT775.08
KT776.08

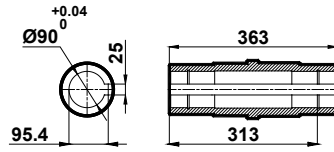
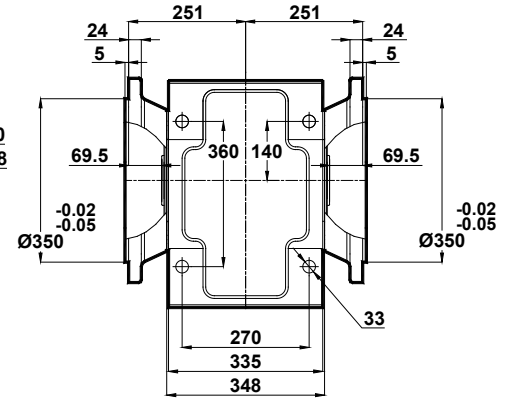
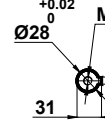
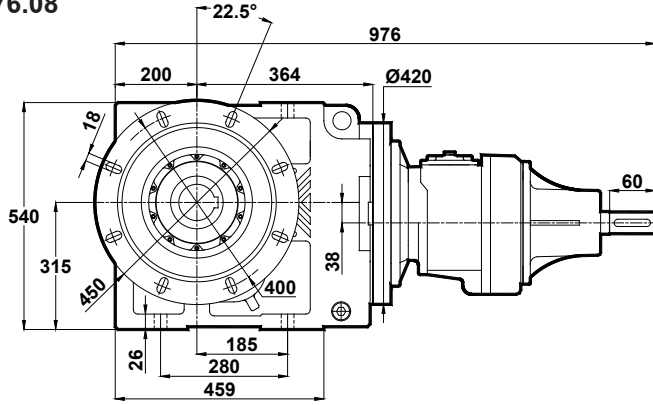

Opsiyonel flanş ölçüleri için sayfa 587'ye bakınız.
Please see on page 587 for optional flange dimensions
Siehe Seite 587 für auswählbare Flanschabmessungen



Ölçü Sayfaları

Dimension Pages

Abmessungenseiten

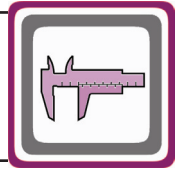

-Mil ucu çekirme deliği DIN 332 sayfa 2 / Tapped center hole to DIN 332, sheet 2 / Zentrierung mit Gewinde DIN 332, Blatt 2

KT873.00

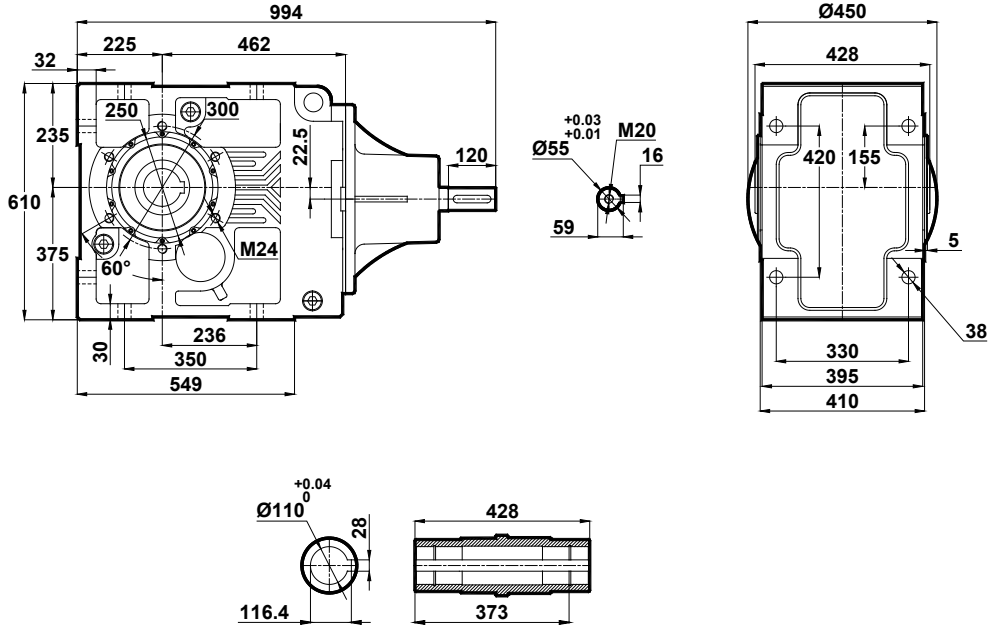

KT873.01

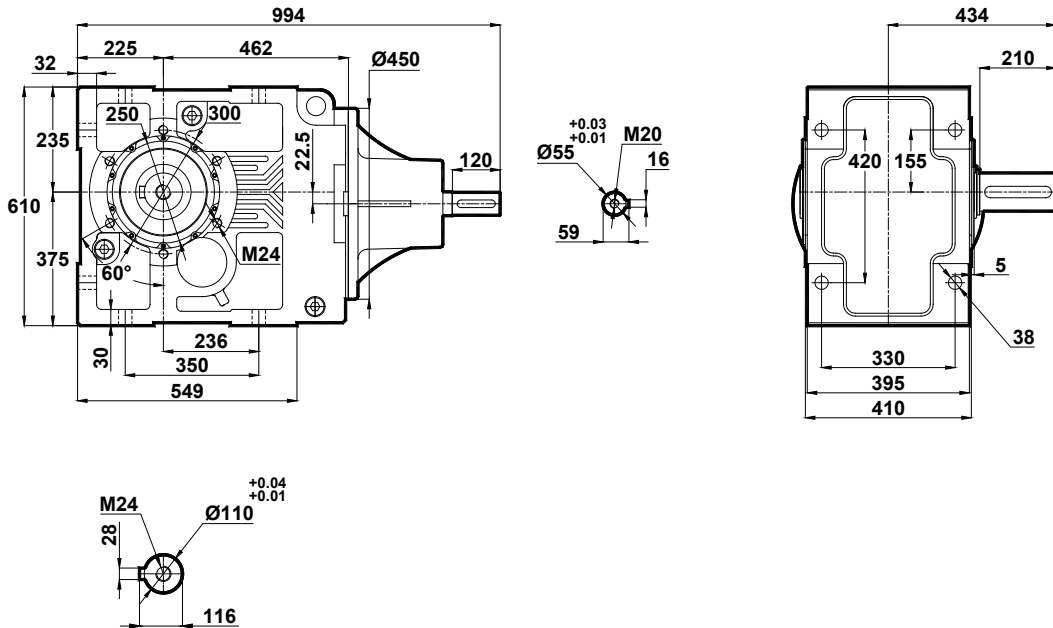



Ölçü Sayfaları Dimension Pages Abmessungenseiten



-Mil ucu çekirme deliği DIN 332 sayfa 2 / Tapped center hole to DIN 332, sheet 2 / Zentrierung mit Gewinde DIN 332, Blatt 2

KT873.02

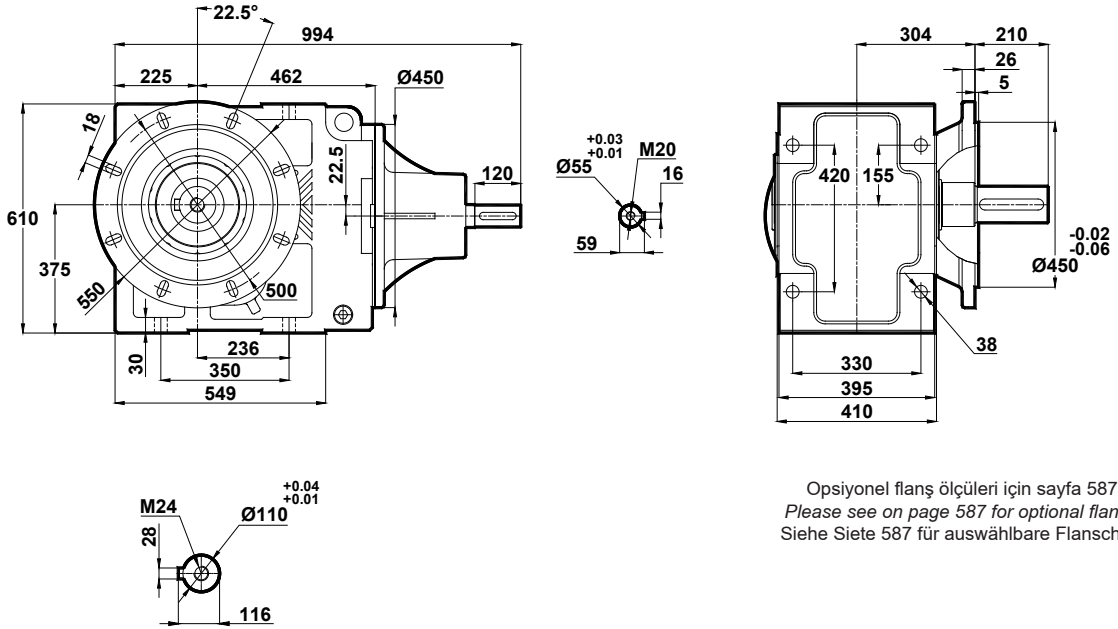

Opsiyonel flanş ölçüleri için sayfa 587'ye bakınız.
Please see on page 587 for optional flange dimensions
Siehe Seite 587 für auswählbare Flanschabmessungen

KT873.03

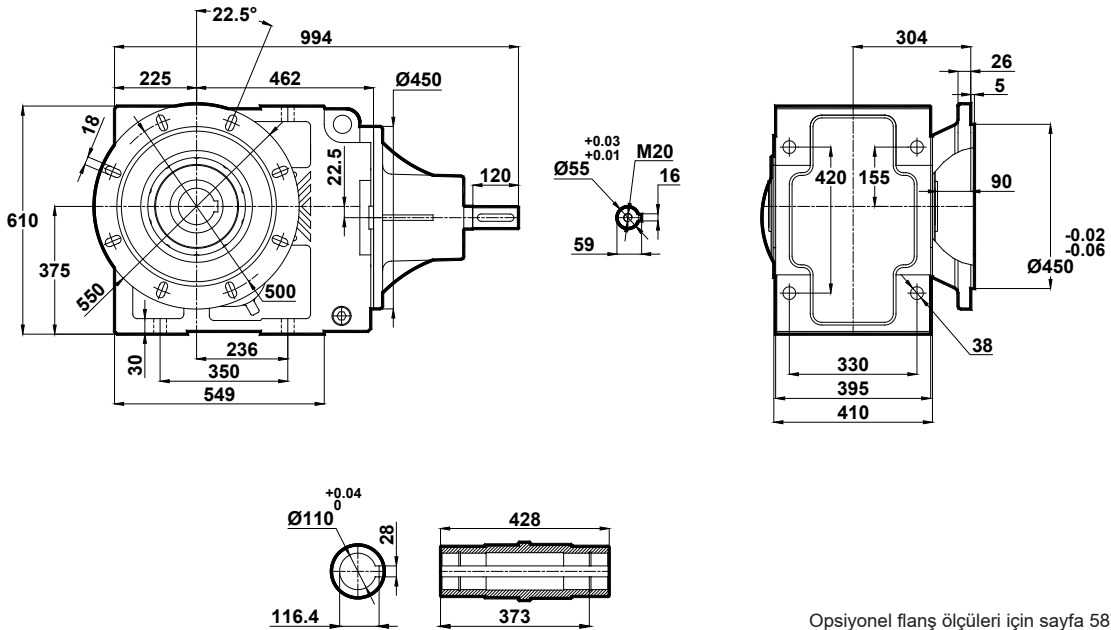

Opsiyonel flanş ölçüleri için sayfa 587'ye bakınız.
Please see on page 587 for optional flange dimensions
Siehe Seite 587 für auswählbare Flanschabmessungen

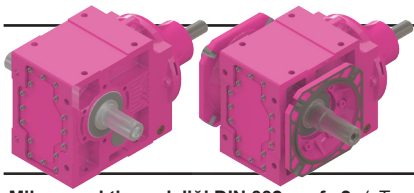

Ölçü Sayfaları Dimension Pages Abmessungenseiten

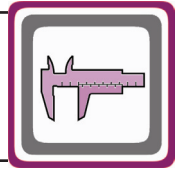

-Mil ucu çekirme deliği DIN 332 sayfa 2 / Tapped center hole to DIN 332, sheet 2 / Zentrierung mit Gewinde DIN 332, Blatt 2

KT873.04

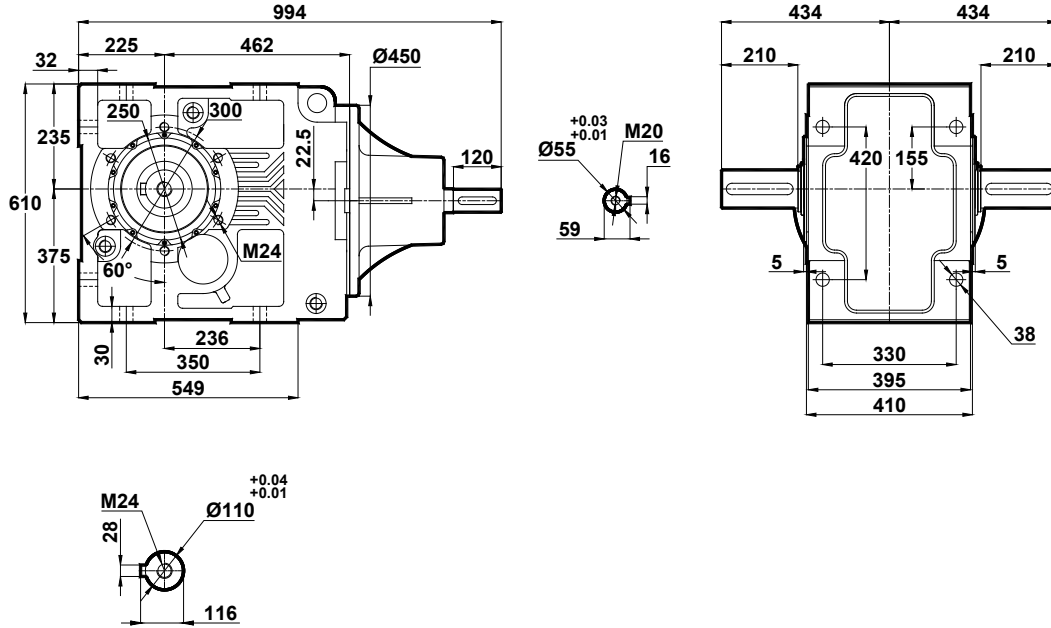

KT873.05

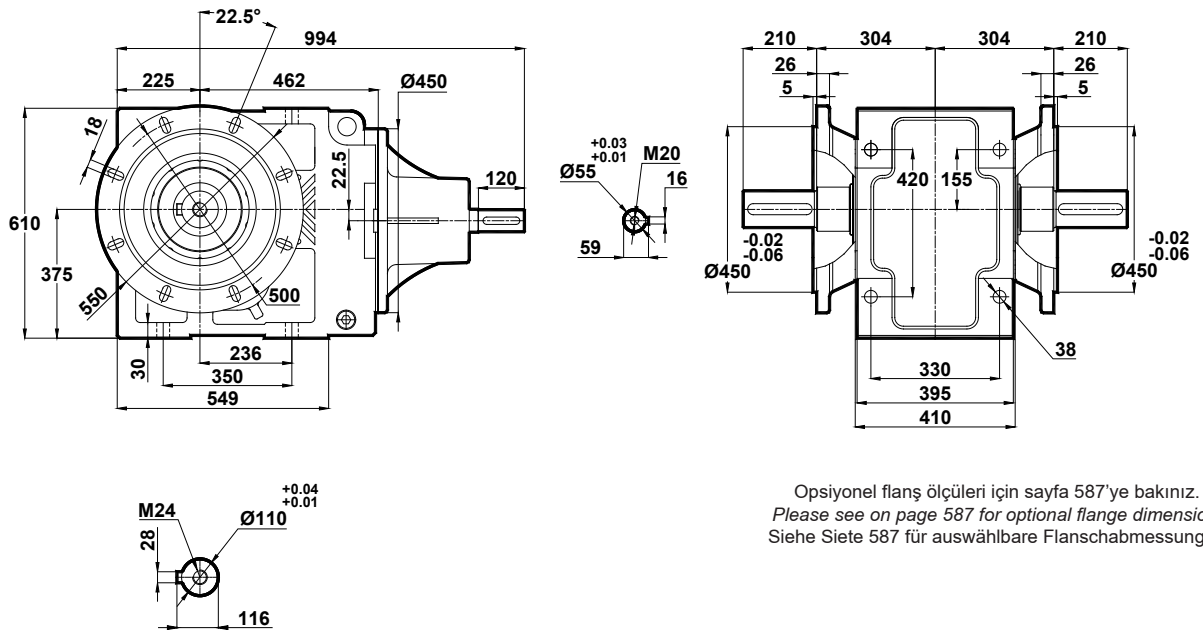

Opsiyonel flanş ölçüleri için sayfa 587'ye bakınız.
Please see on page 587 for optional flange dimensions
Siehe Seite 587 für auswählbare Flanschabmessungen



Ölçü Sayfaları Dimension Pages Abmessungenseiten



-Mil ucu çektirme deliği DIN 332 sayfa 2 / Tapped center hole to DIN 332, sheet 2 / Zentrierung mit Gewinde DIN 332, Blatt 2

KT873.08

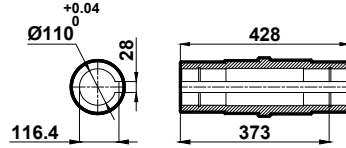
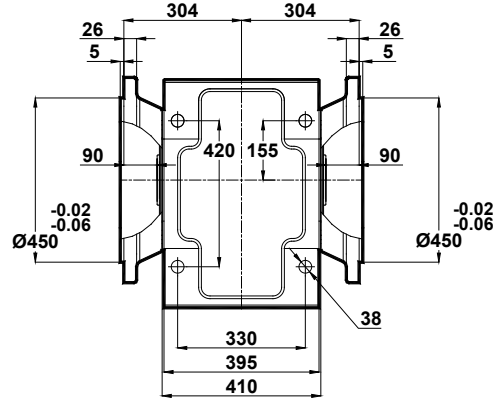
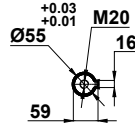
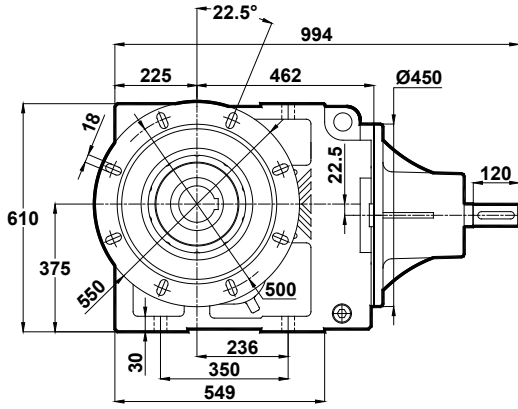

Opsiyonel flanş ölçüleri için sayfa 587'ye bakınız.
Please see on page 587 for optional flange dimensions
Siehe Seite 587 für auswählbare Flanschabmessungen



Ölçü Sayfaları

Dimension Pages

Abmessungsseiten

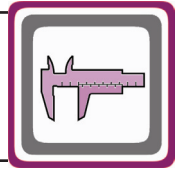

-Mil ucu çekirme deliği DIN 332 sayfa 2 / Tapped center hole to DIN 332, sheet 2 / Zentrierung mit Gewinde DIN 332, Blatt 2

KT874.00

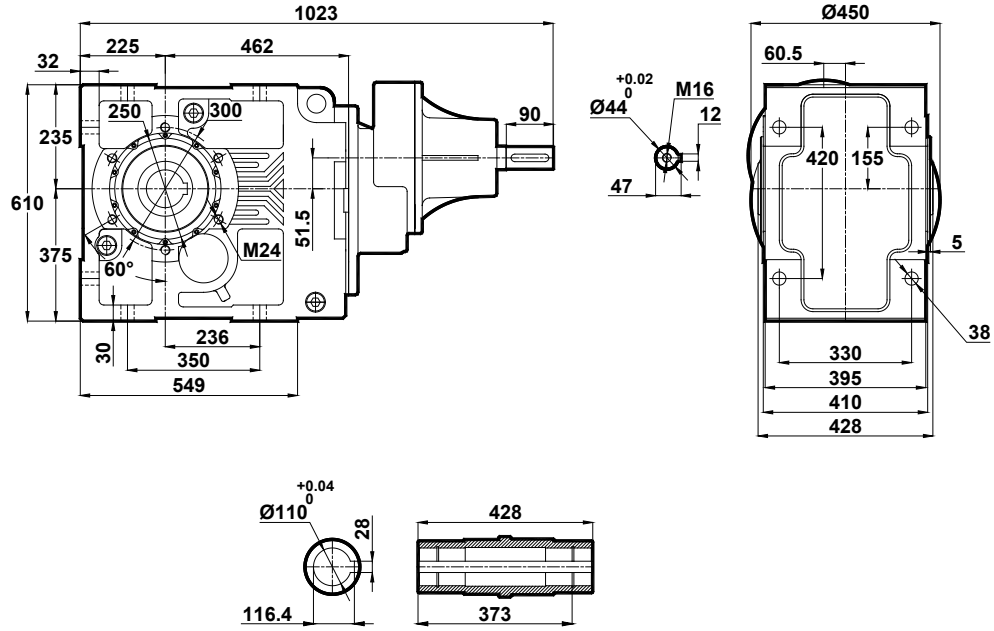

KT874.01

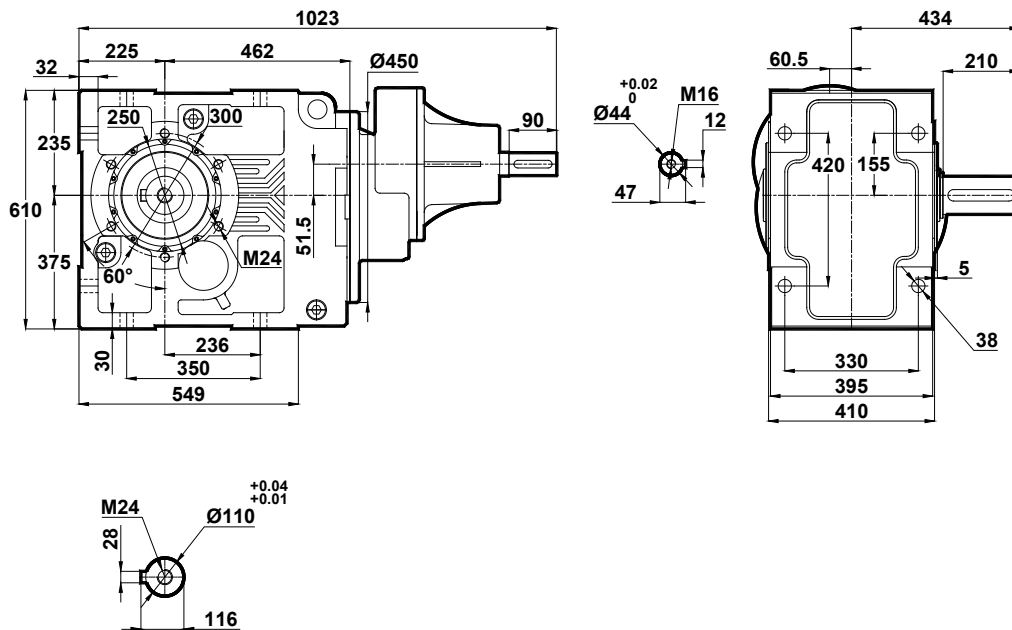



Ölçü Sayfaları Dimension Pages Abmessungenseiten



-Mil ucu çekirme deliği DIN 332 sayfa 2 / Tapped center hole to DIN 332, sheet 2 / Zentrierung mit Gewinde DIN 332, Blatt 2

KT874.02

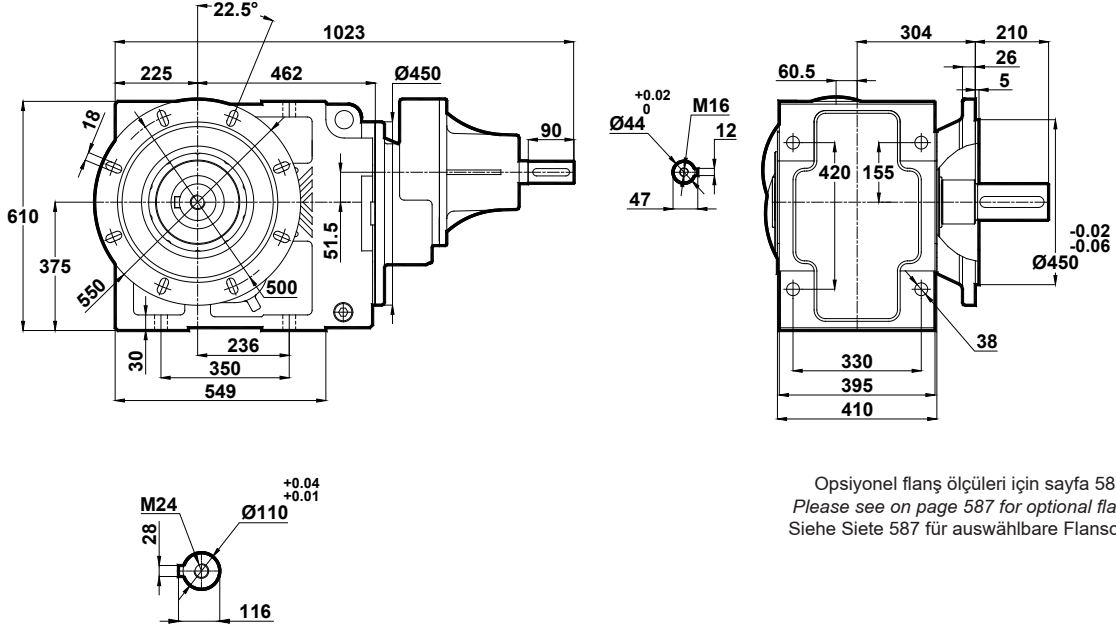

Opsiyonel flanş ölçüleri için sayfa 587'ye bakınız.
Please see on page 587 for optional flange dimensions
Siehe Seite 587 für auswählbare Flanschabmessungen

KT874.03

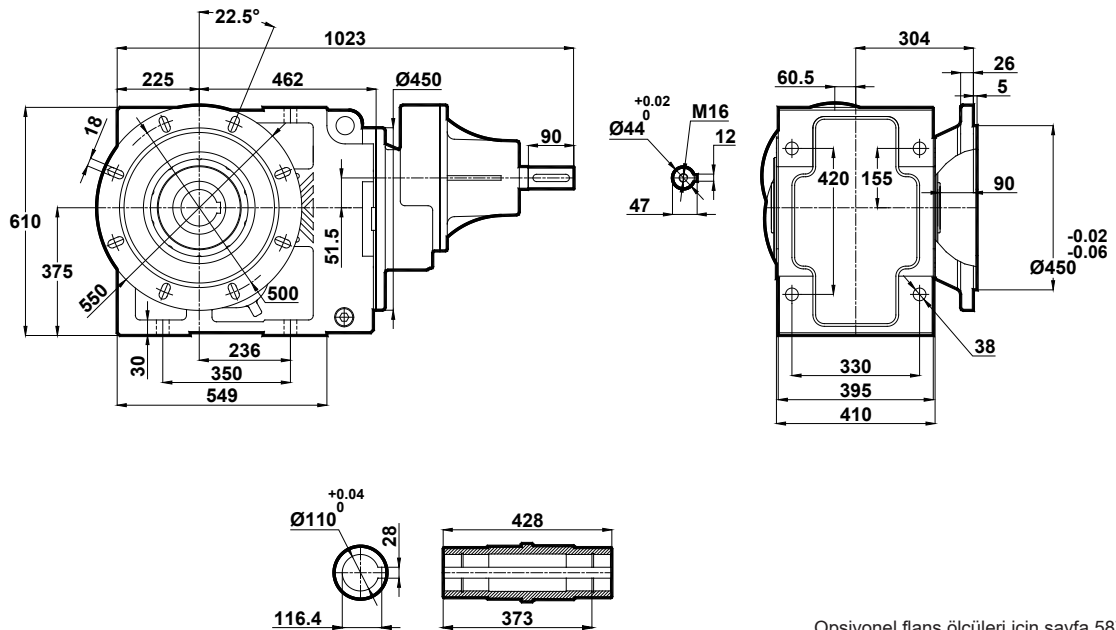

Opsiyonel flanş ölçüleri için sayfa 587'ye bakınız.
Please see on page 587 for optional flange dimensions
Siehe Seite 587 für auswählbare Flanschabmessungen

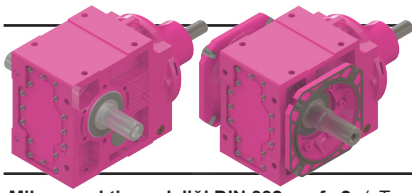

Ölçü Sayfaları Dimension Pages Abmessungsseiten

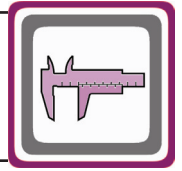

-Mil ucu çekirme deliği DIN 332 sayfa 2 / Tapped center hole to DIN 332, sheet 2 / Zentrierung mit Gewinde DIN 332, Blatt 2

KT874.04

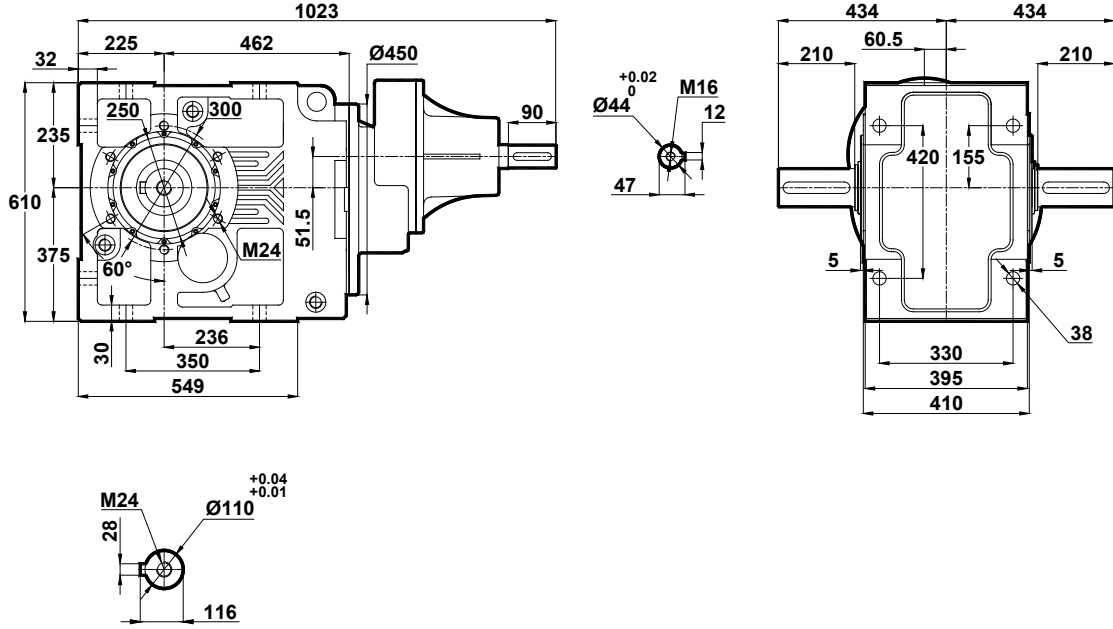

KT874.05

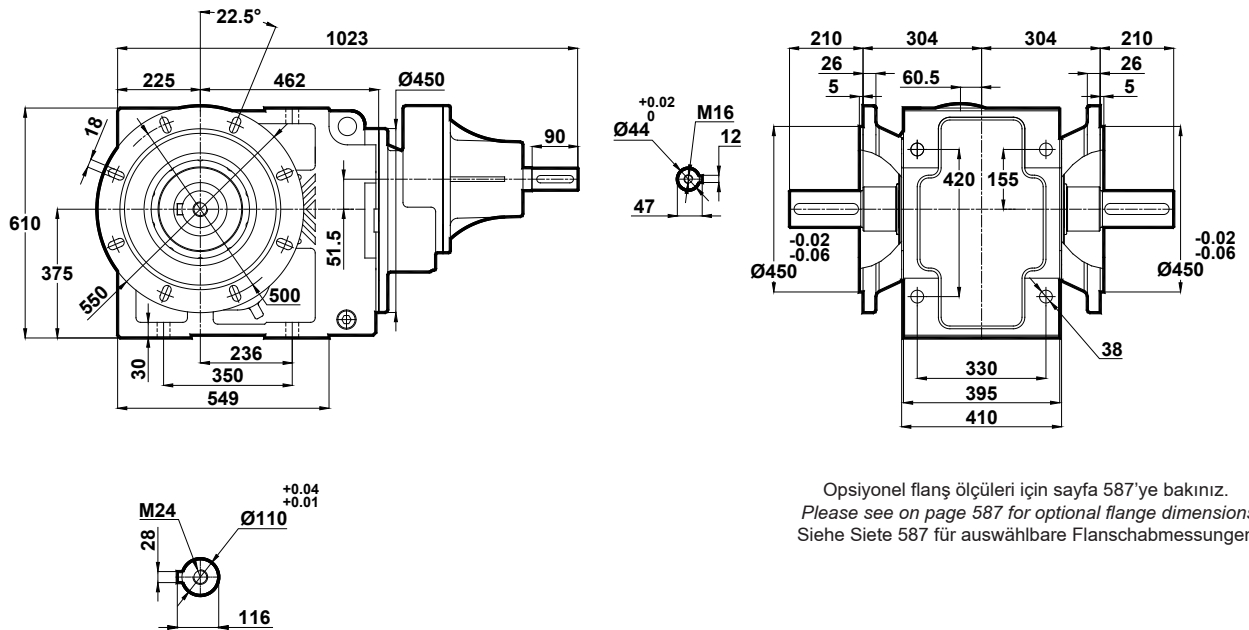

Opsiyonel flanş ölçüleri için sayfa 587'ye bakınız.
Please see on page 587 for optional flange dimensions
Siehe Seite 587 für auswählbare Flanschabmessungen



Ölçü Sayfaları

Dimension Pages

Abmessungsseiten



-Mil ucu çekirme deliği DIN 332 sayfa 2 / Tapped center hole to DIN 332, sheet 2 / Zentrierung mit Gewinde DIN 332, Blatt 2

KT874.08

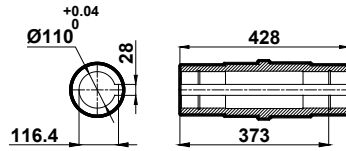
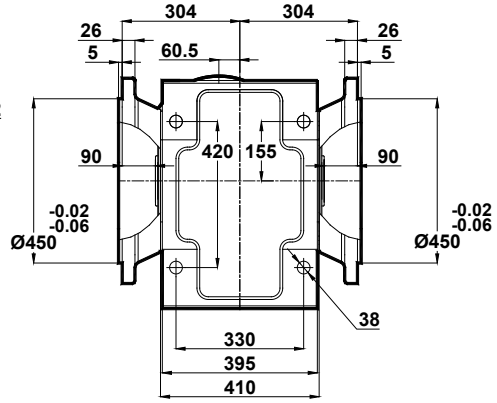
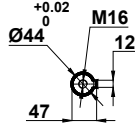
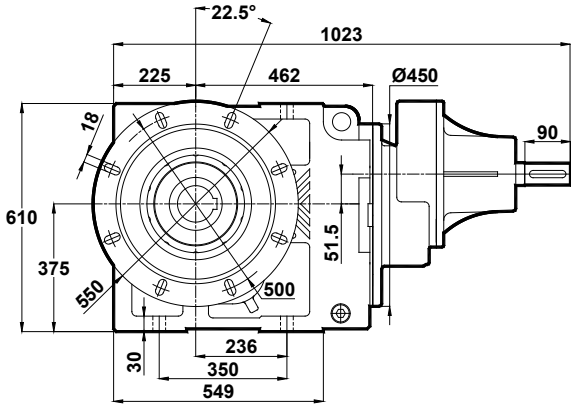

Opsiyonel flanş ölçüleri için sayfa 587'ye bakınız.
Please see on page 587 for optional flange dimensions
Siehe Seite 587 für auswählbare Flanschabmessungen



Ölçü Sayfaları

Dimension Pages

Abmessungsseiten

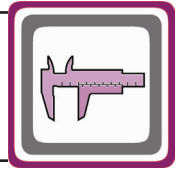

-Mil ucu çektirme deliği DIN 332 sayfa 2 / Tapped center hole to DIN 332, sheet 2 / Zentrierung mit Gewinde DIN 332, Blatt 2

KT875.00
KT876.00

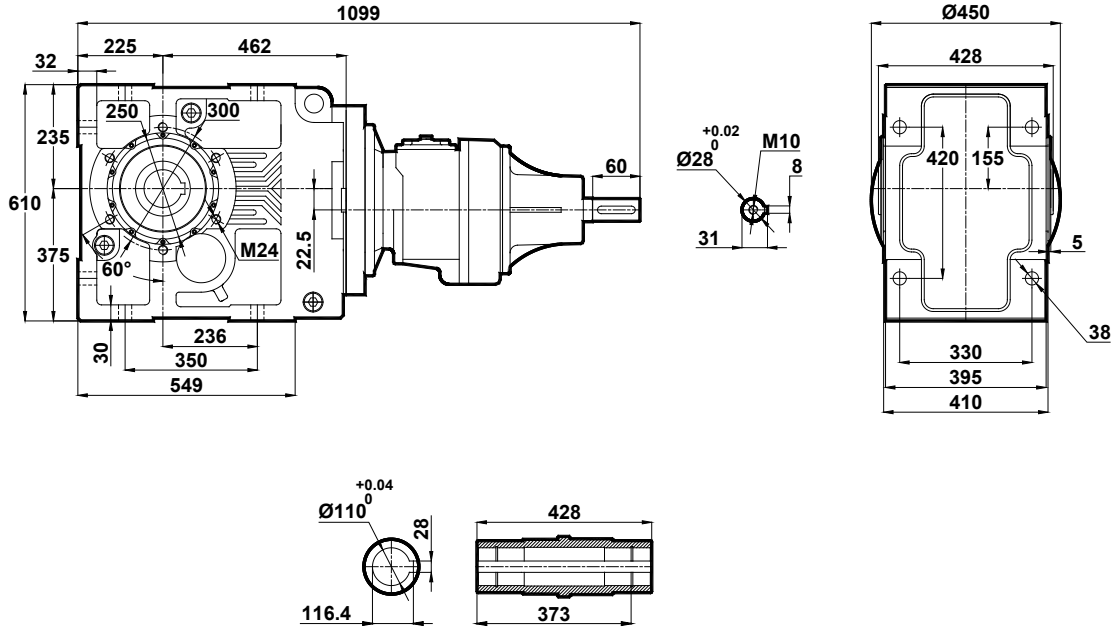

KT875.01
KT876.01

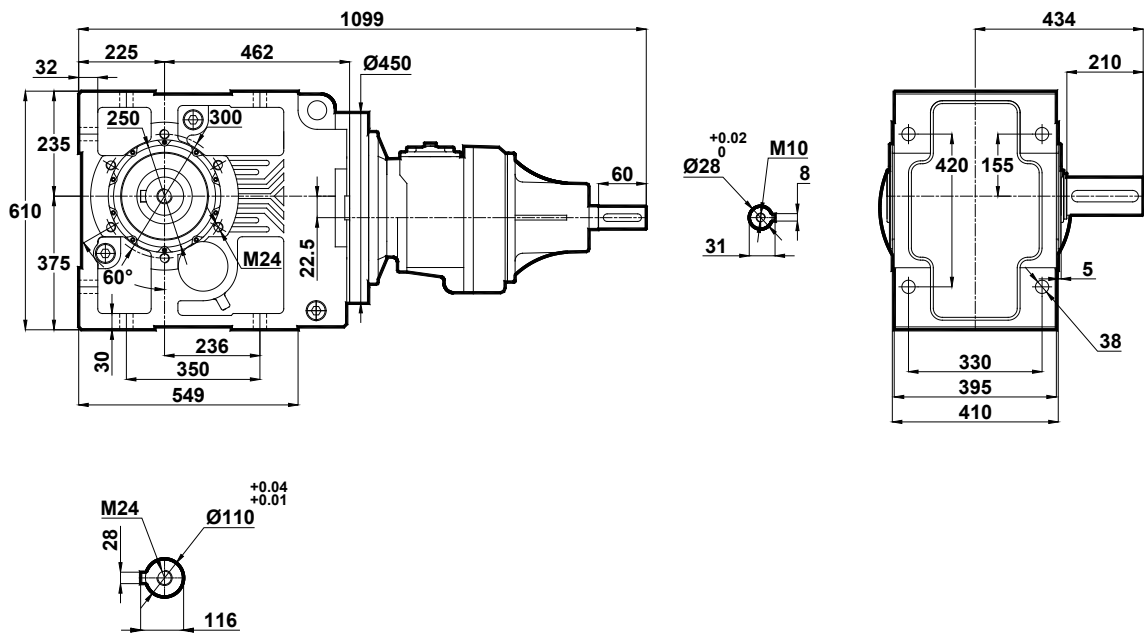



Ölçü Sayfaları

Dimension Pages

Abmessungsseiten



-Mil ucu çekirme deliği DIN 332 sayfa 2 / Tapped center hole to DIN 332, sheet 2 / Zentrierung mit Gewinde DIN 332, Blatt 2

KT875.02
KT876.02

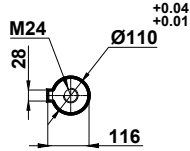
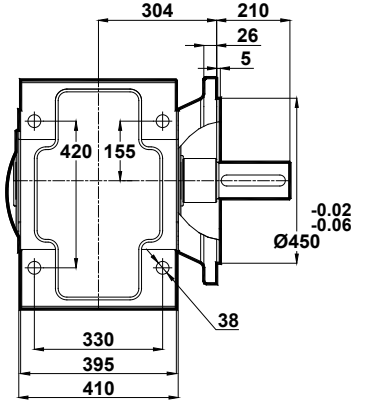
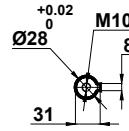
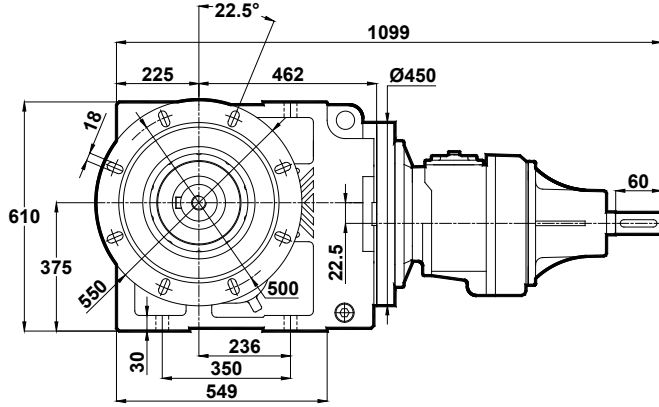

Opsiyonel flanş ölçüleri için sayfa 587'ye bakınız.
Please see on page 587 for optional flange dimensions
Siehe Seite 587 für auswählbare Flanschabmessungen

KT875.03
KT876.03

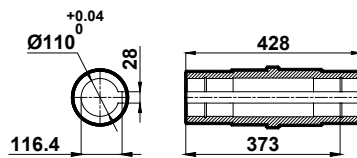
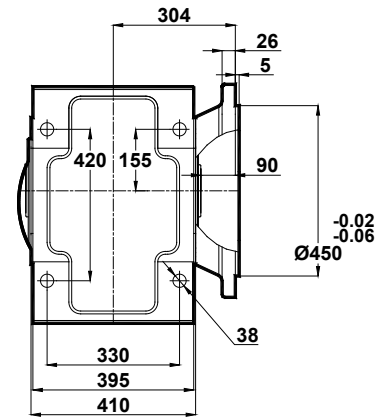
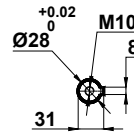
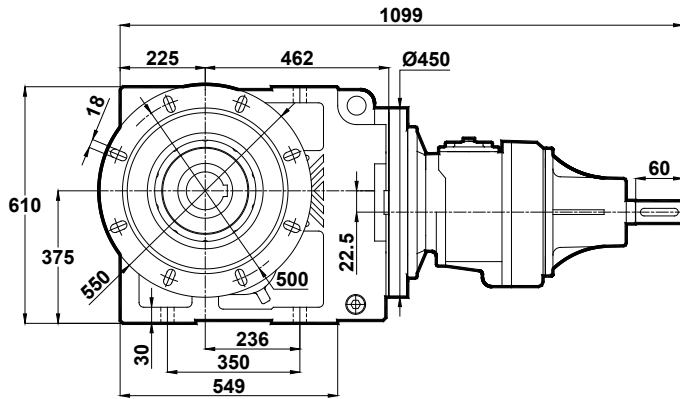

Opsiyonel flanş ölçüleri için sayfa 587'ye bakınız.
Please see on page 587 for optional flange dimensions
Siehe Seite 587 für auswählbare Flanschabmessungen

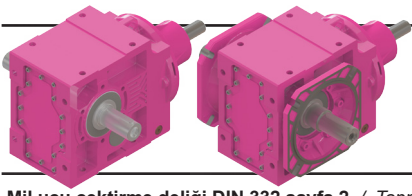

Ölçü Sayfaları

Dimension Pages

Abmessungsseiten

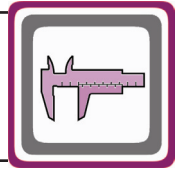

-Mil ucu çekirtme deliği DIN 332 sayfa 2 / Tapped center hole to DIN 332, sheet 2 / Zentrierung mit Gewinde DIN 332, Blatt 2

KT875.04
KT876.04

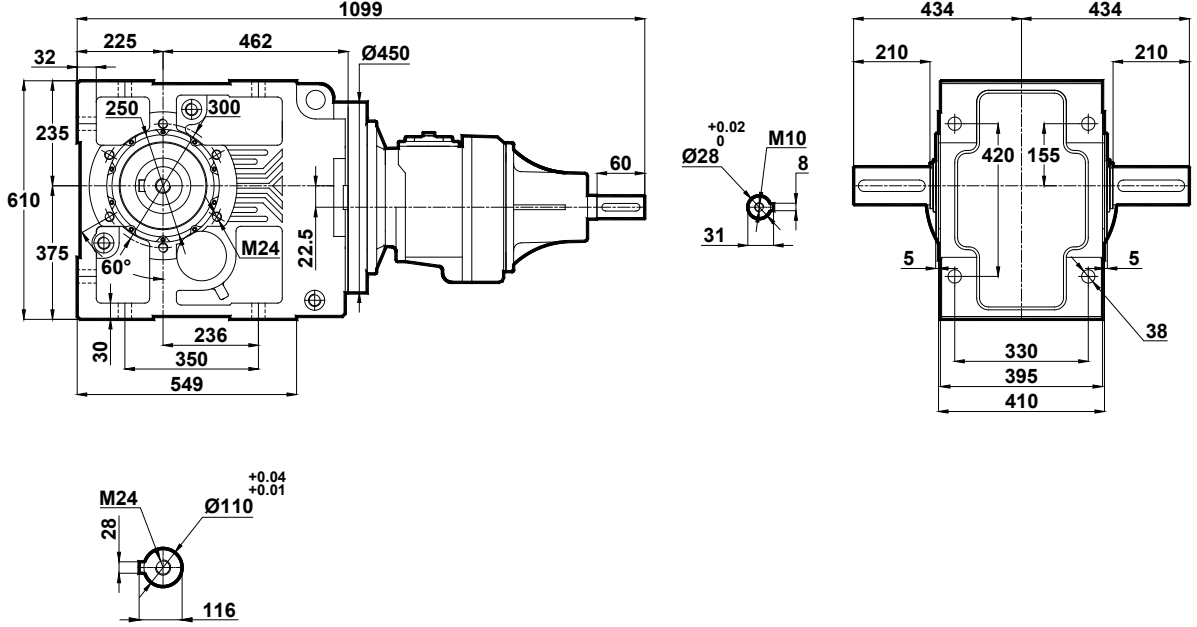

KT875.05
KT876.05

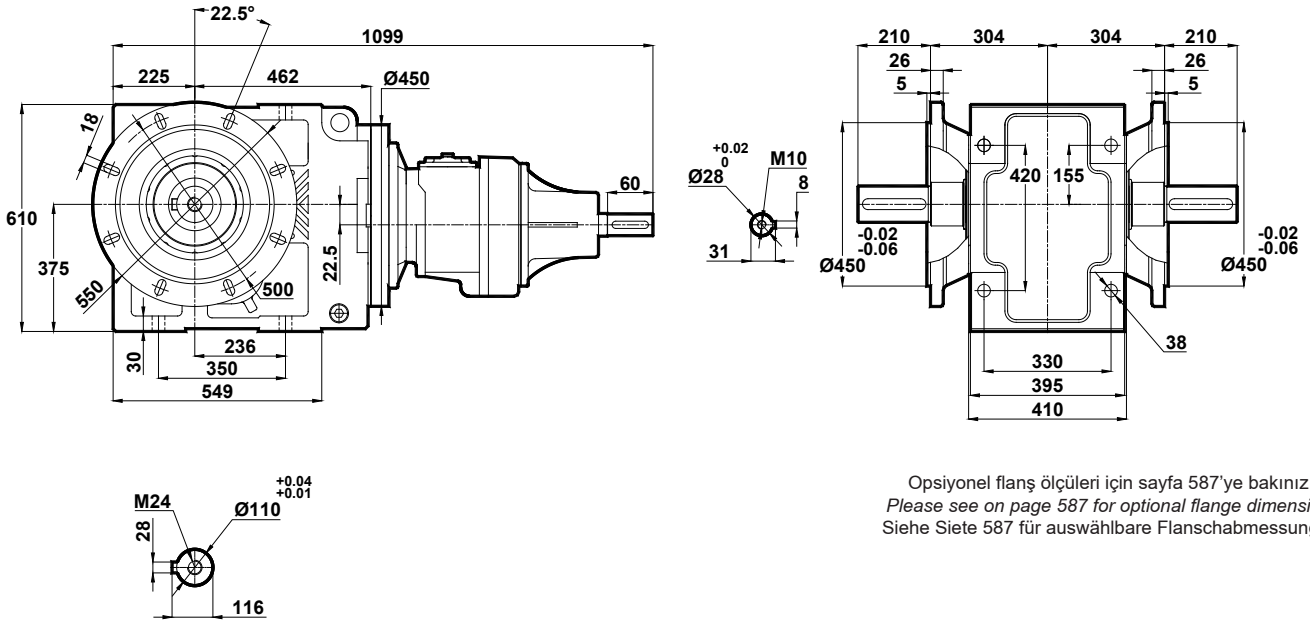

Opsiyonel flanş ölçüleri için sayfa 587'ye bakınız.
Please see on page 587 for optional flange dimensions
Siehe Seite 587 für auswählbare Flanschabmessungen



Ölçü Sayfaları Dimension Pages Abmessungenseiten



-Mil ucu çekirme deliği DIN 332 sayfa 2 / Tapped center hole to DIN 332, sheet 2 / Zentrierung mit Gewinde DIN 332, Blatt 2

KT875.08
KT876.08

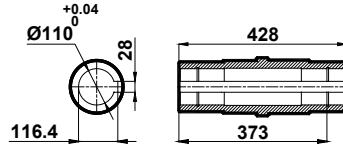
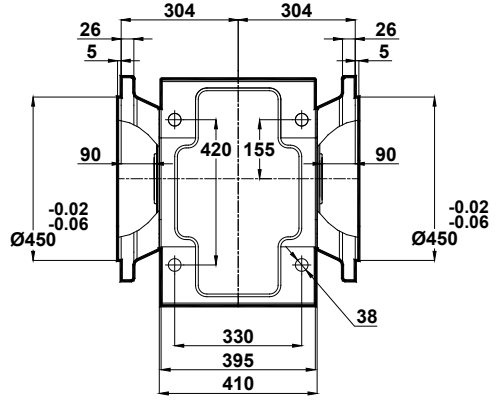
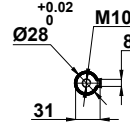
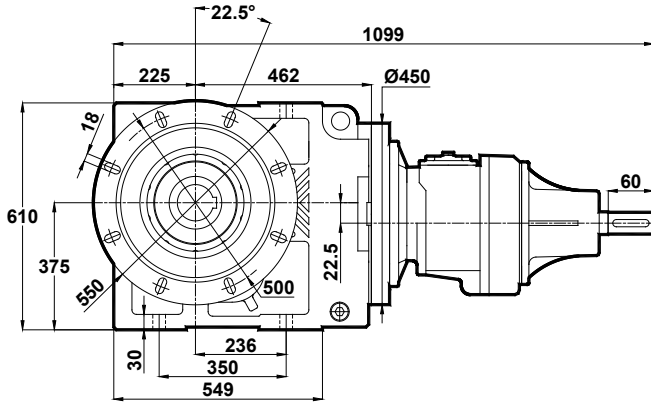

Opsiyonel flanş ölçüleri için sayfa 587'ye bakınız.
Please see on page 587 for optional flange dimensions
Siehe Seite 587 für auswählbare Flanschabmessungen



Ölçü Sayfaları

Dimension Pages

Abmessungsseiten

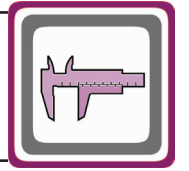

-Mil ucu çekirme deliği DIN 332 sayfa 2 / Tapped center hole to DIN 332, sheet 2 / Zentrierung mit Gewinde DIN 332, Blatt 2

KT973.00

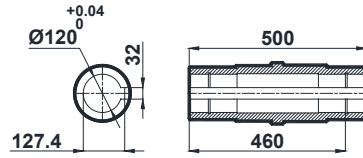
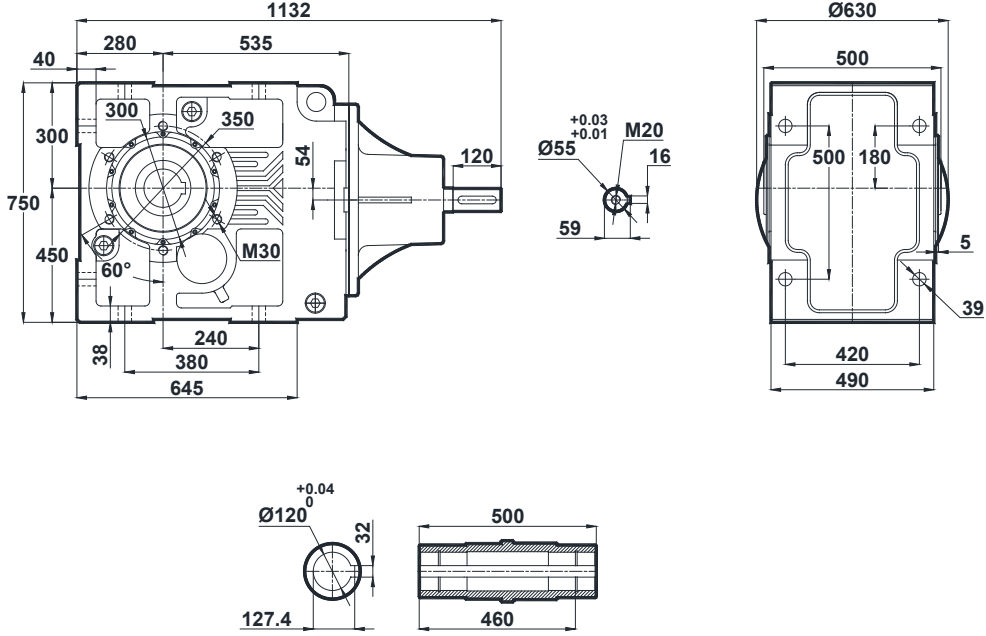

KT973.01

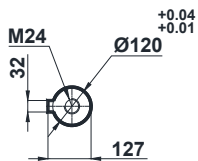
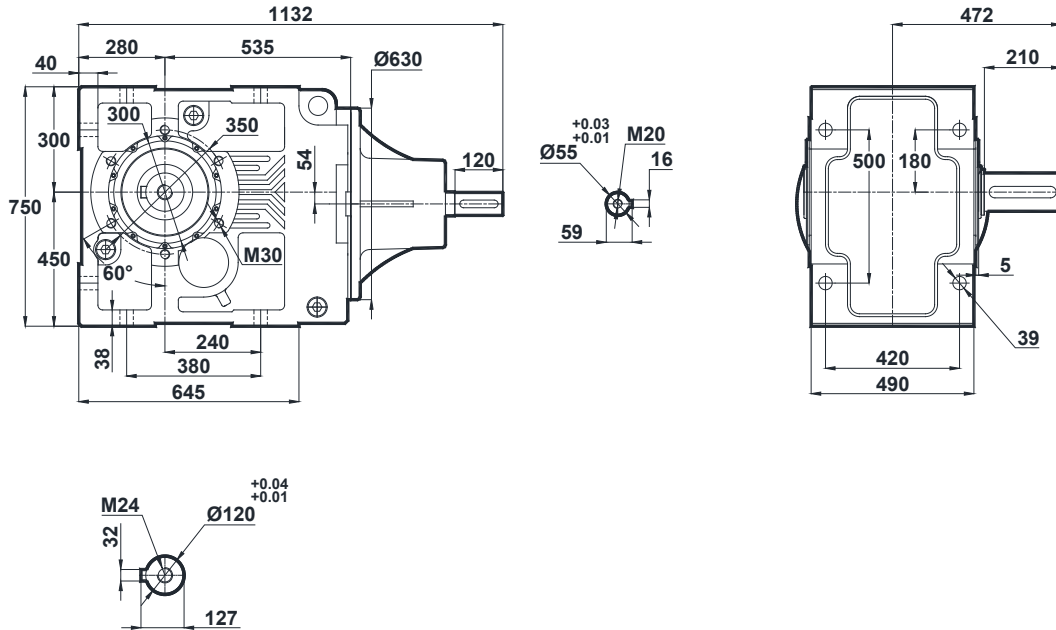



Ölçü Sayfaları

Dimension Pages

Abmessungsseiten



-Mil ucu çektirme deliği DIN 332 sayfa 2 / Tapped center hole to DIN 332, sheet 2 / Zentrierung mit Gewinde DIN 332, Blatt 2

KT973.02

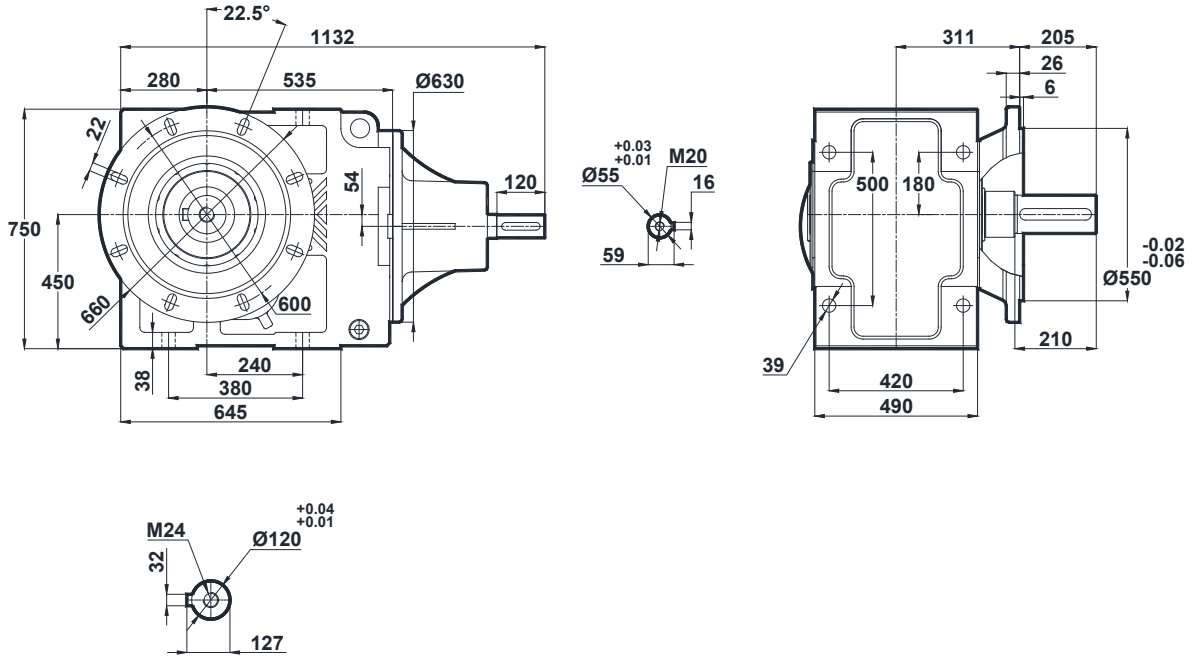

KT973.03

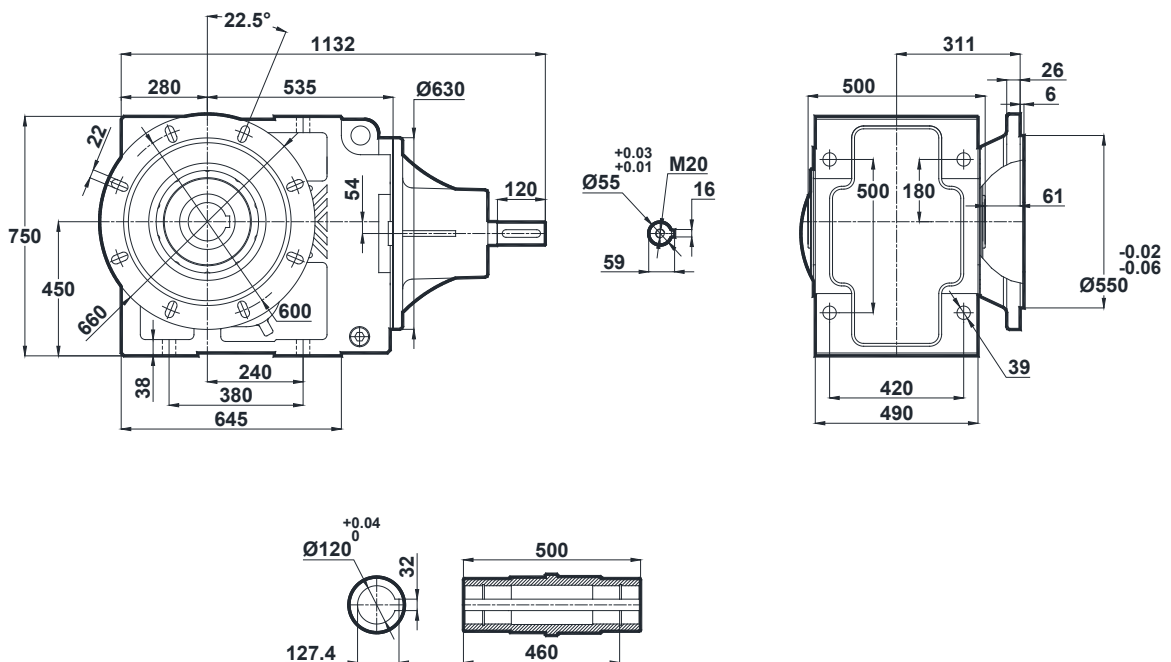

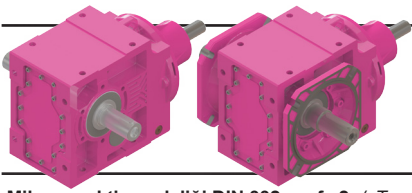

Ölçü Sayfaları

Dimension Pages

Abmessungsseiten

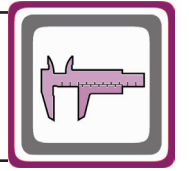

-Mil ucu çekirme deliği DIN 332 sayfa 2 / Tapped center hole to DIN 332, sheet 2 / Zentrierung mit Gewinde DIN 332, Blatt 2

KT973.04

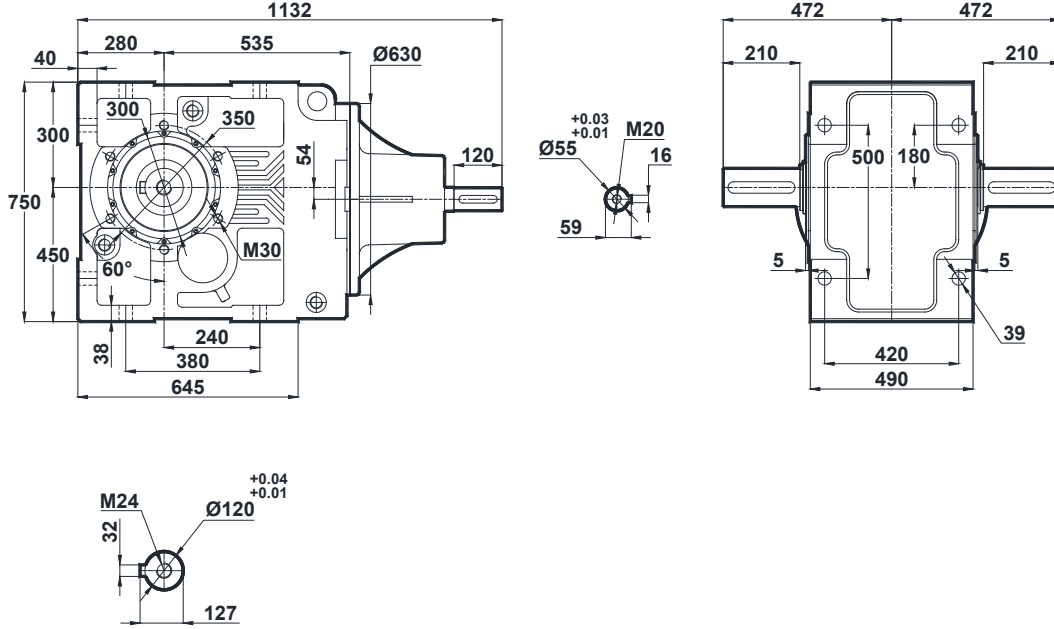

KT973.05

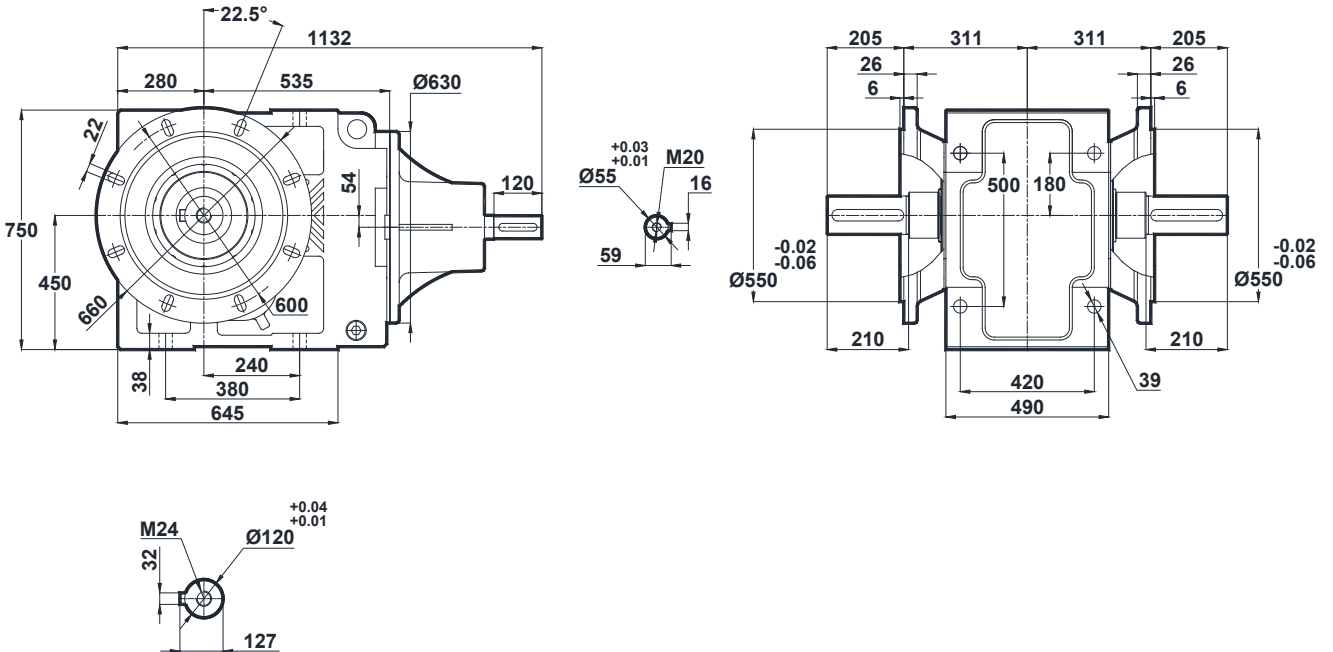



Ölçü Sayfaları

Dimension Pages

Abmessungsseiten



-Mil ucu çektirme deliği DIN 332 sayfa 2 / Tapped center hole to DIN 332, sheet 2 / Zentrierung mit Gewinde DIN 332, Blatt 2

KT973.08

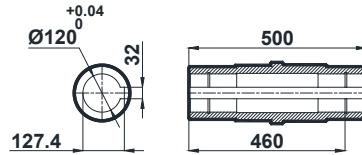
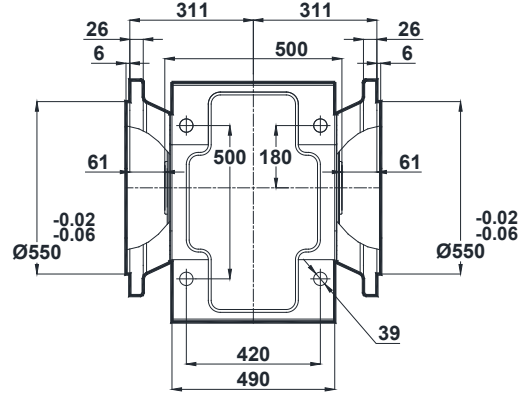
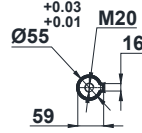
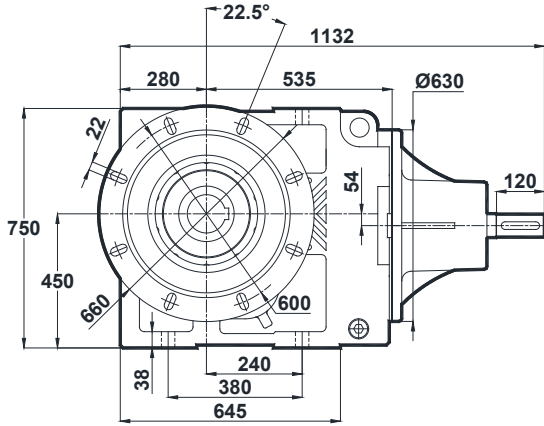



Ölçü Sayfaları

Dimension Pages

Abmessungsseiten

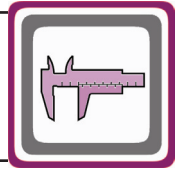

-Mil ucu çekirme deliği DIN 332 sayfa 2 / Tapped center hole to DIN 332, sheet 2 / Zentrierung mit Gewinde DIN 332, Blatt 2

KT974.00

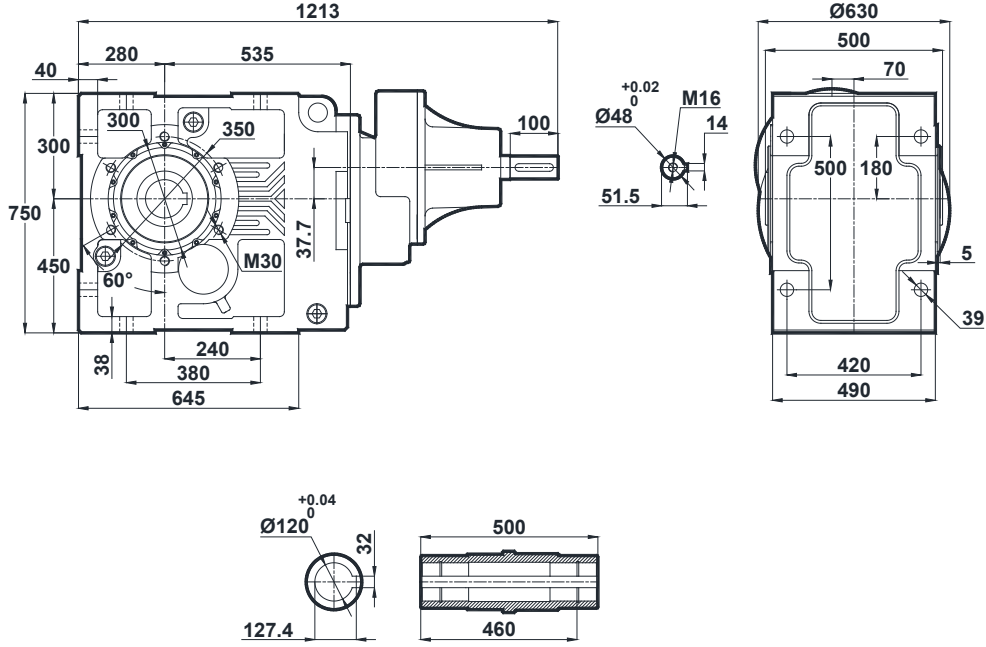

KT974.01

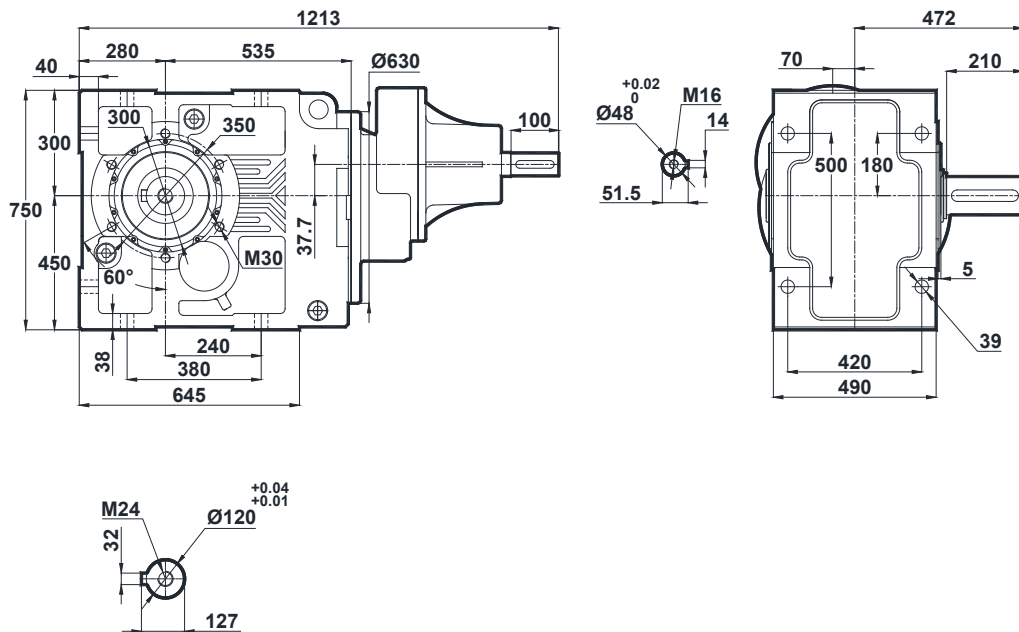



Ölçü Sayfaları

Dimension Pages

Abmessungenseiten



-Mil ucu çekirme deliği DIN 332 sayfa 2 / Tapped center hole to DIN 332, sheet 2 / Zentrierung mit Gewinde DIN 332, Blatt 2

KT974.02

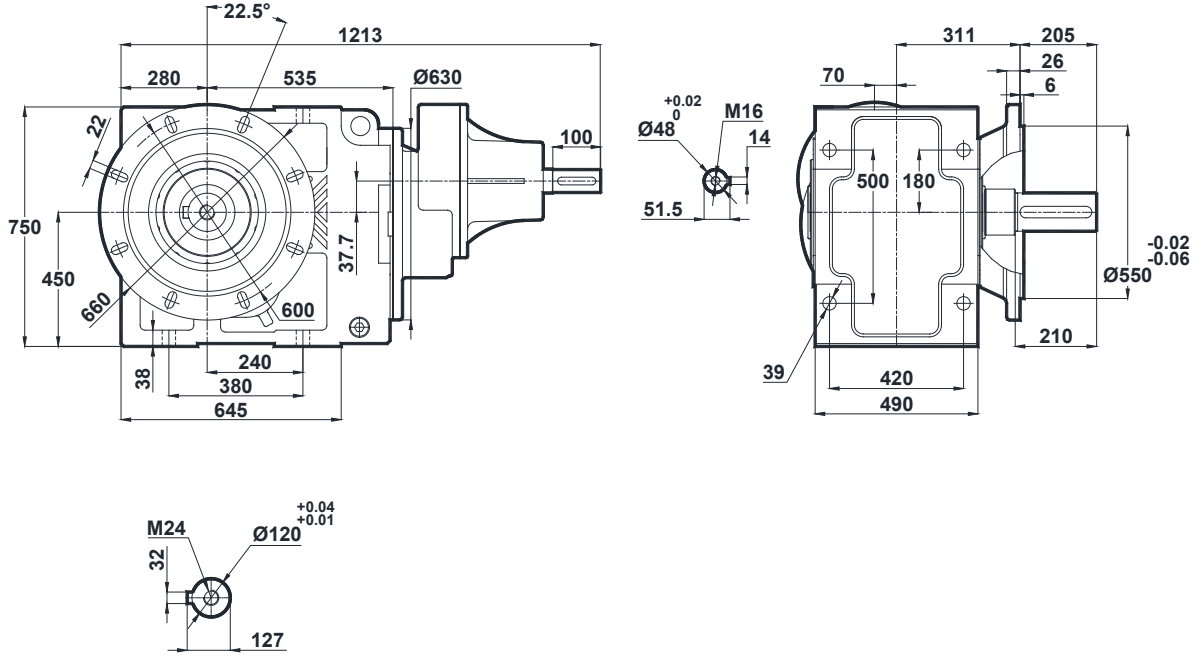

KT974.03

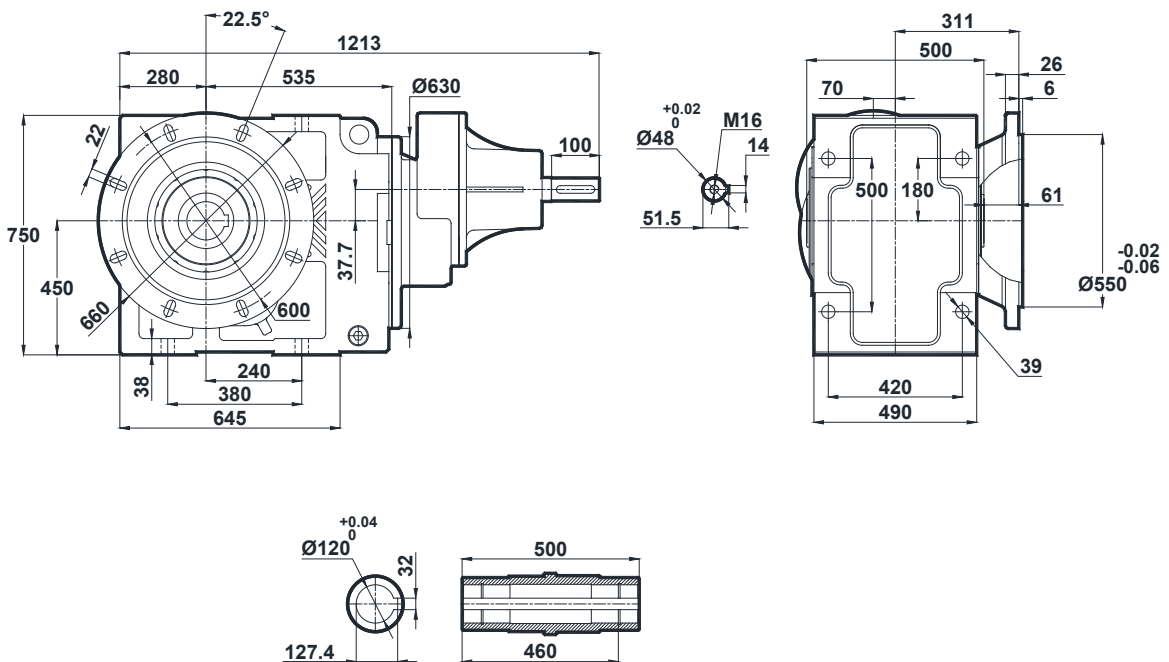

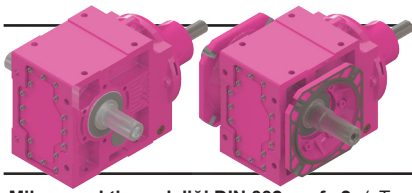

Ölçü Sayfaları

Dimension Pages

Abmessungsseiten

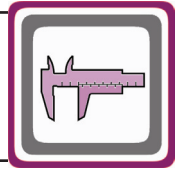

-Mil ucu çekirme deliği DIN 332 sayfa 2 / Tapped center hole to DIN 332, sheet 2 / Zentrierung mit Gewinde DIN 332, Blatt 2

KT974.04

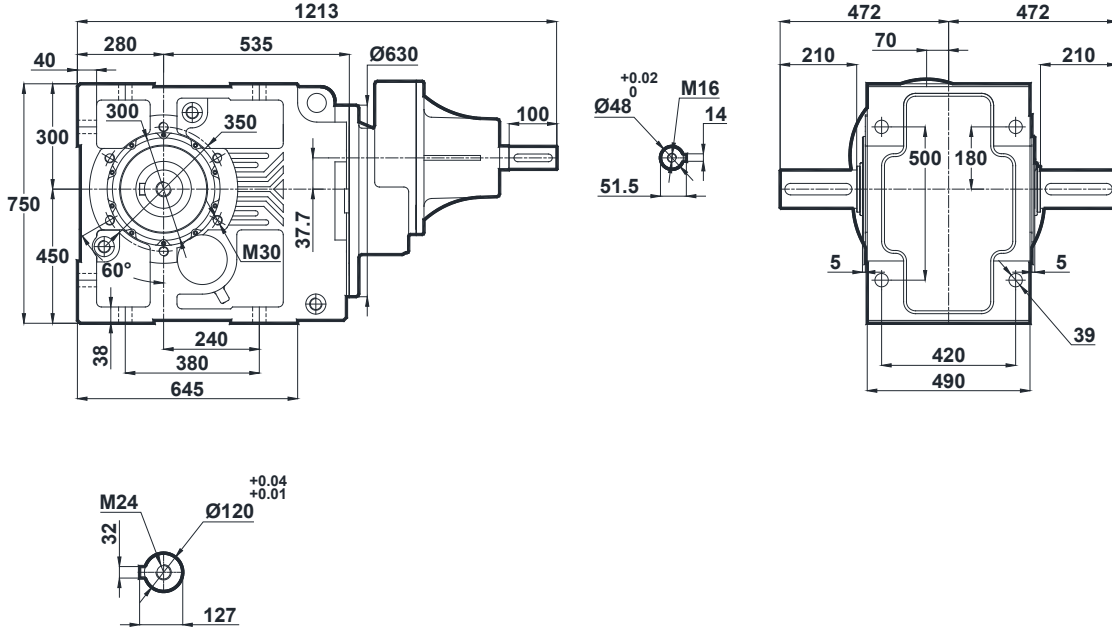

KT974.05

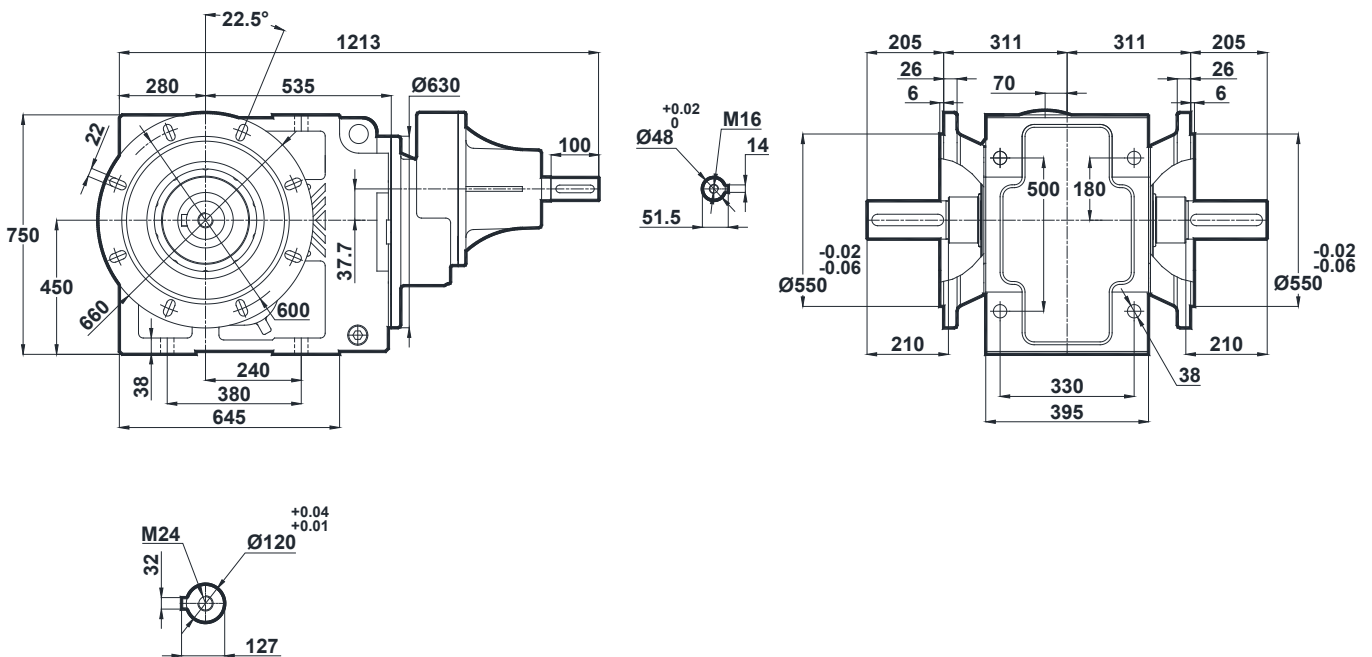



Ölçü Sayfaları

Dimension Pages

Abmessungsseiten

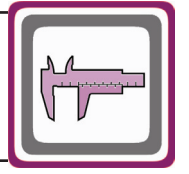

-Mil ucu çekirme deliği DIN 332 sayfa 2 / Tapped center hole to DIN 332, sheet 2 / Zentrierung mit Gewinde DIN 332, Blatt 2

KT975.00
KT976.00

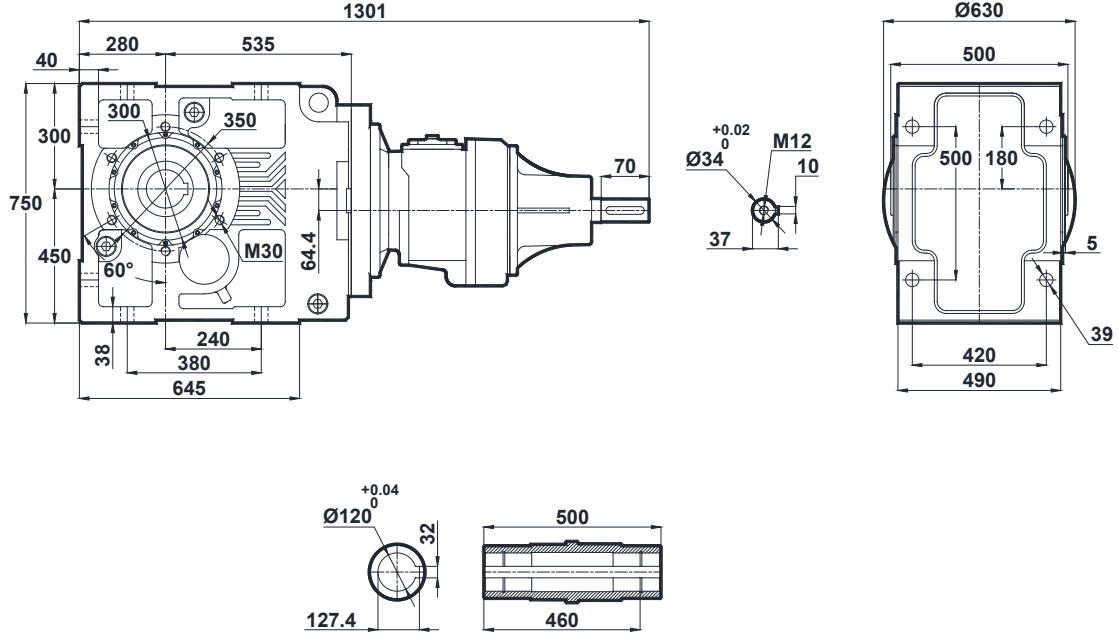

KT975.01
KT976.01

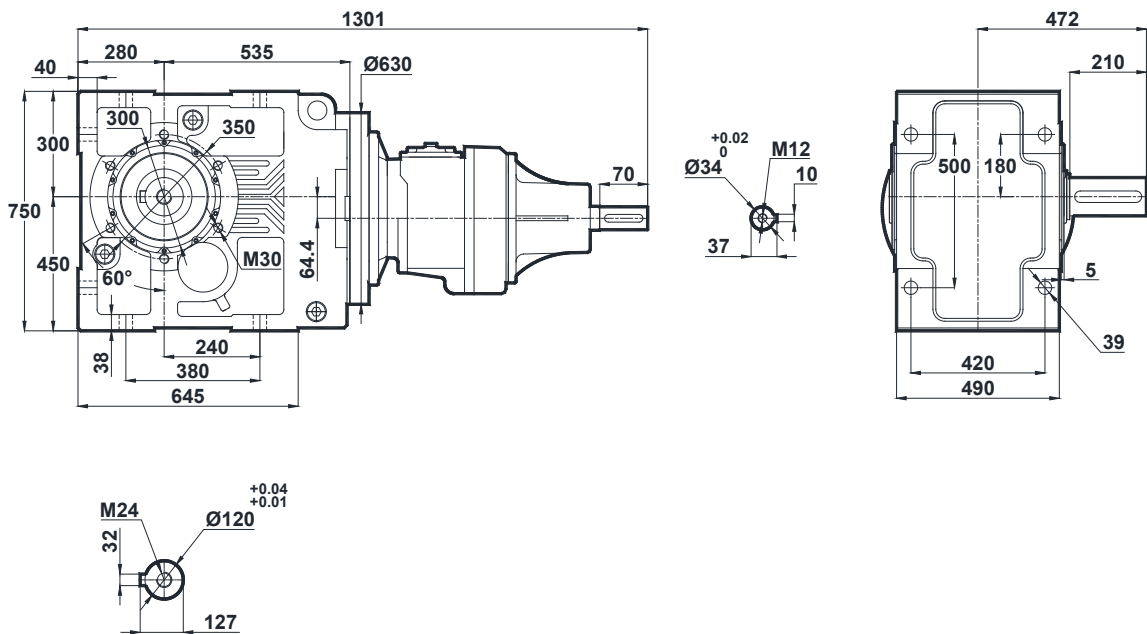



Ölçü Sayfaları

Dimension Pages

Abmessungsseiten



-Mil ucu çektirme deliği DIN 332 sayfa 2 / Tapped center hole to DIN 332, sheet 2 / Zentrierung mit Gewinde DIN 332, Blatt 2

KT975.02
KT976.02

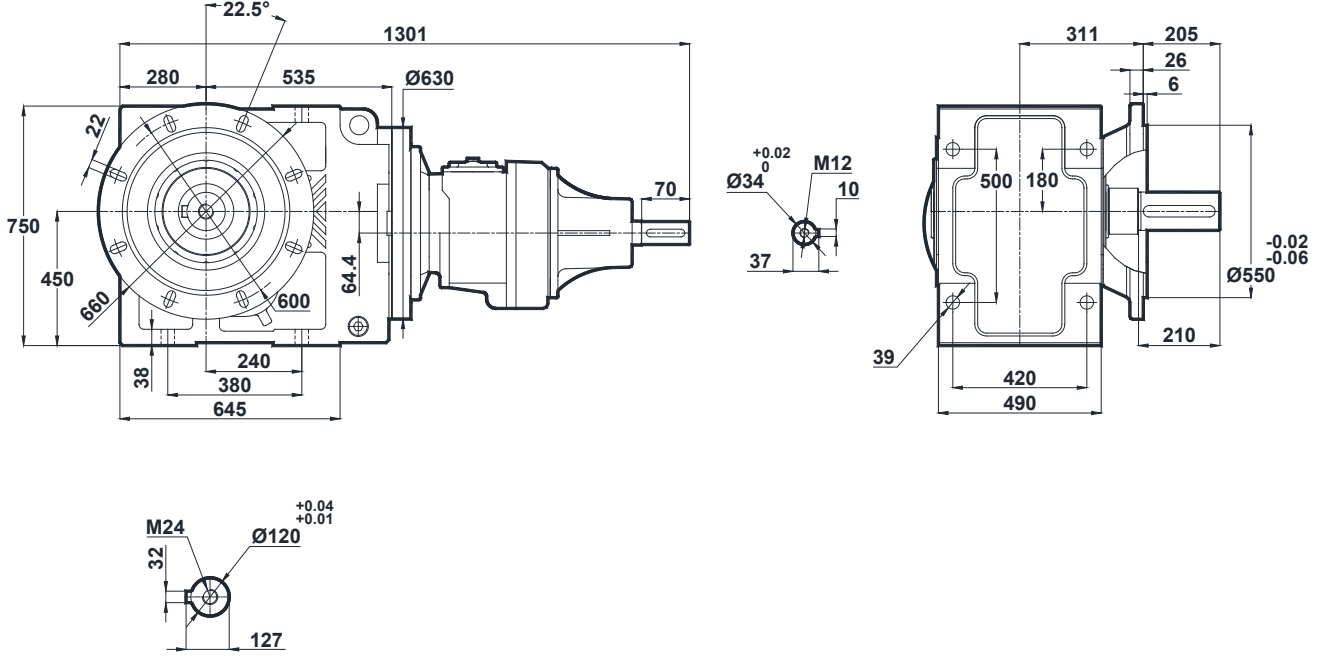

KT975.03
KT976.03

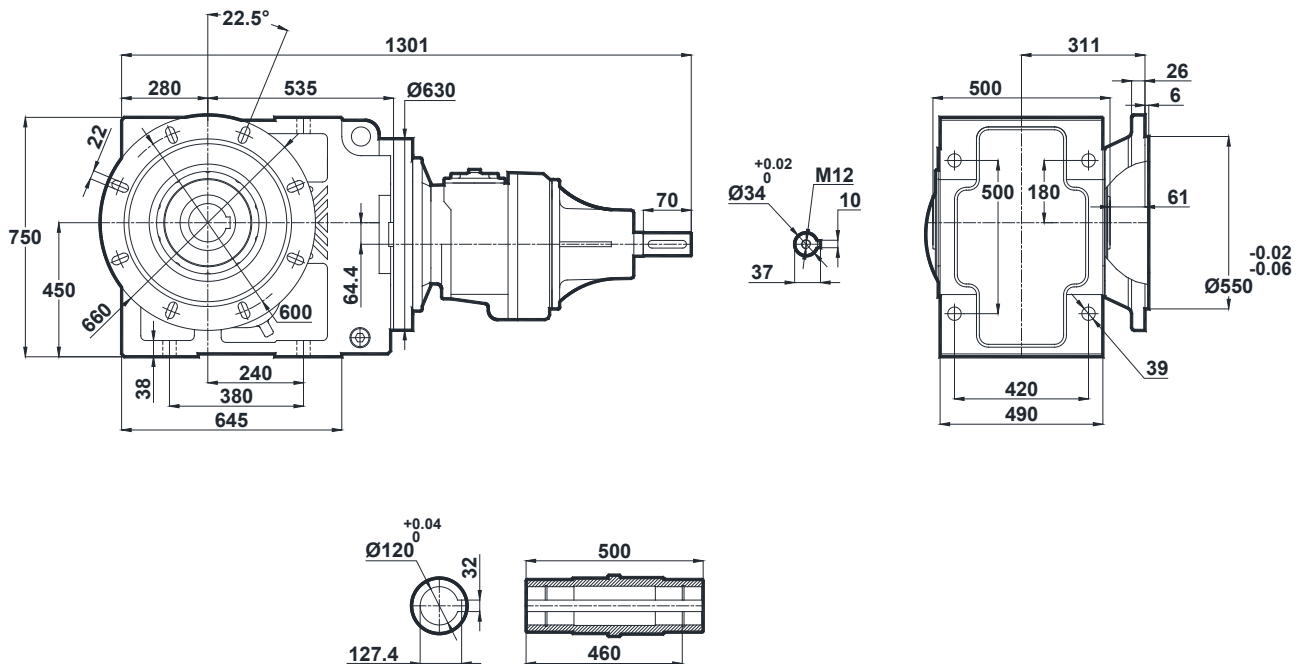

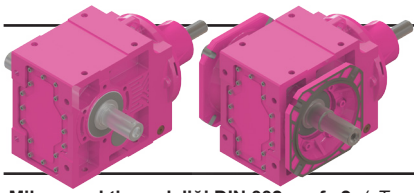

Ölçü Sayfaları

Dimension Pages

Abmessungsseiten

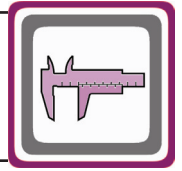

-Mil ucu çekirme deliği DIN 332 sayfa 2 / Tapped center hole to DIN 332, sheet 2 / Zentrierung mit Gewinde DIN 332, Blatt 2

KT975.04
KT976.04

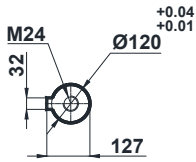
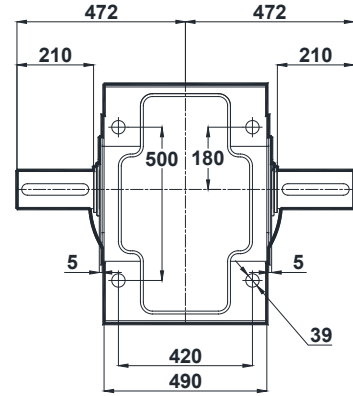
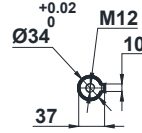
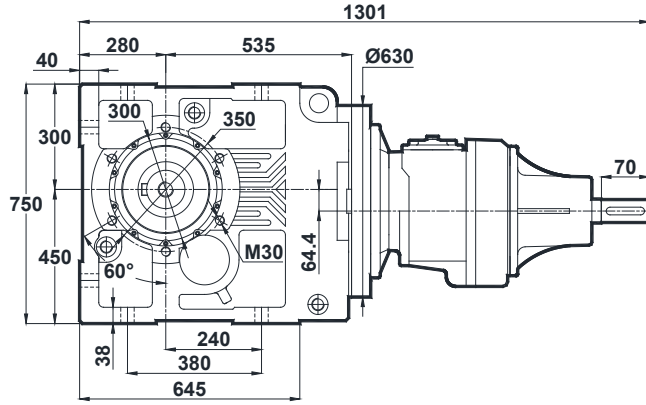

KT975.05
KT976.05

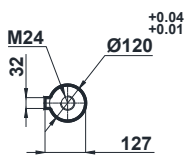
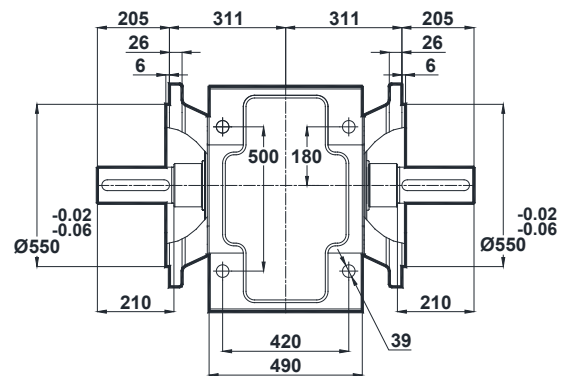
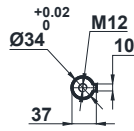
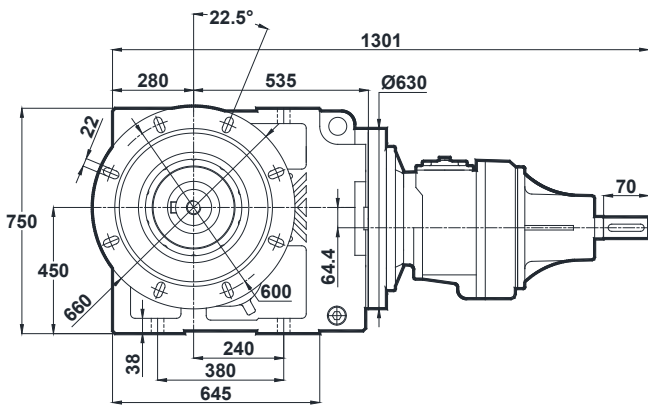



Ölçü Sayfaları Dimension Pages Abmessungenseiten



-Mil ucu çekirme deliği DIN 332 sayfa 2 / Tapped center hole to DIN 332, sheet 2 / Zentrierung mit Gewinde DIN 332, Blatt 2

KT975.08
KT976.08

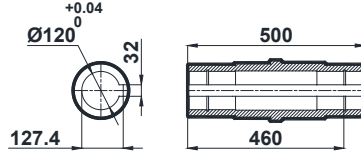
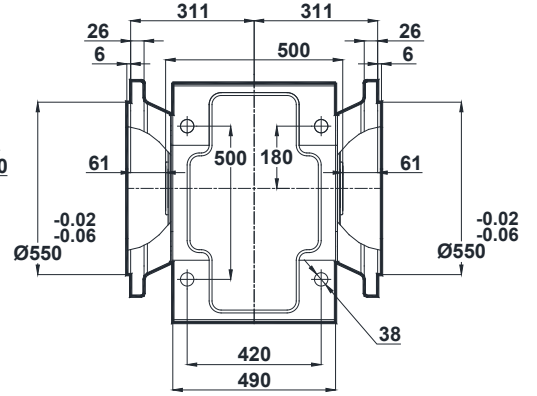
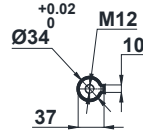
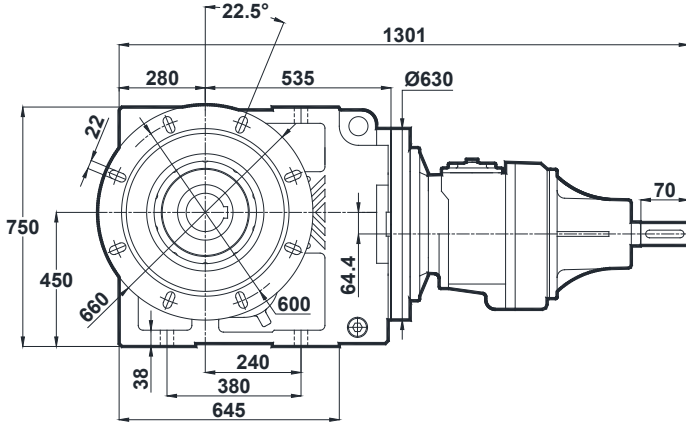

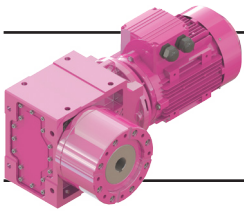

Ölçü Sayfaları
Dimension Pages
Abmessungenseiten

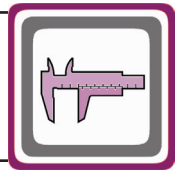

K SERİSİ EKSTRUDER TİP REDÜKTÖRLER
K SERIES EXTRUDER TYPE GEARBOXES
EXTRUDER GETRIEBEN VON K SERIE GETRIEBEN

K.27.E

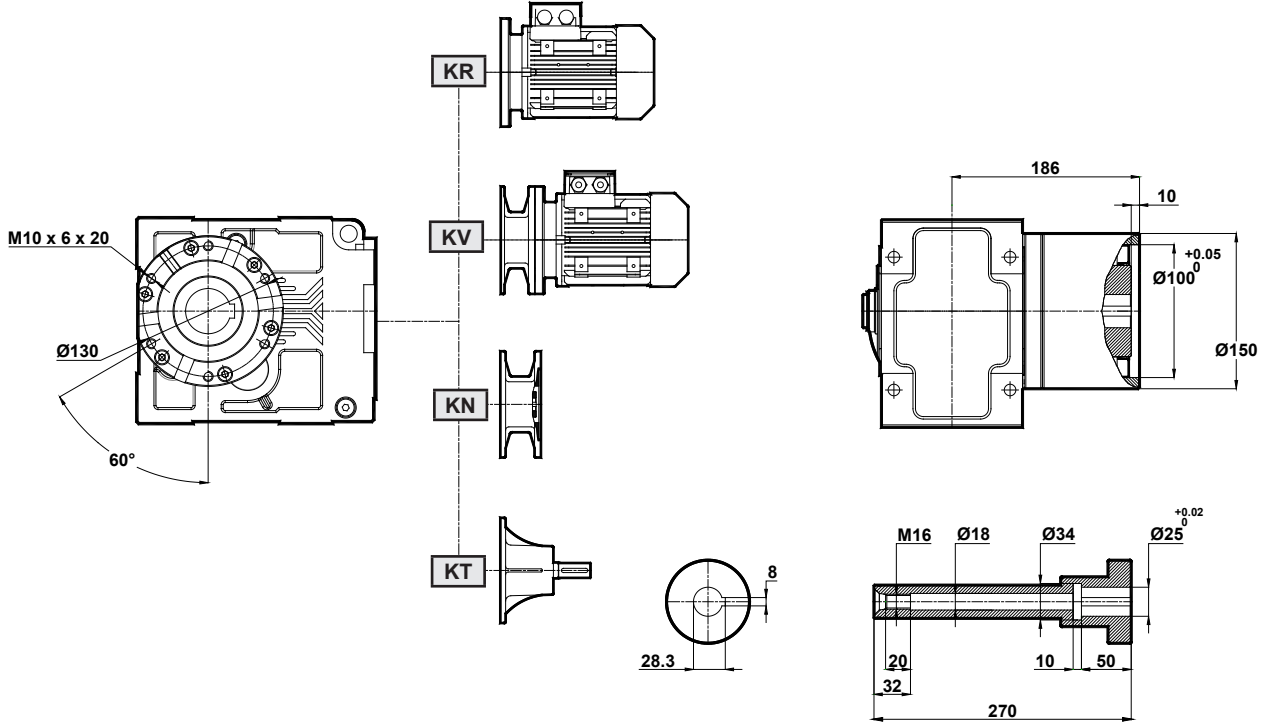

K.28.E

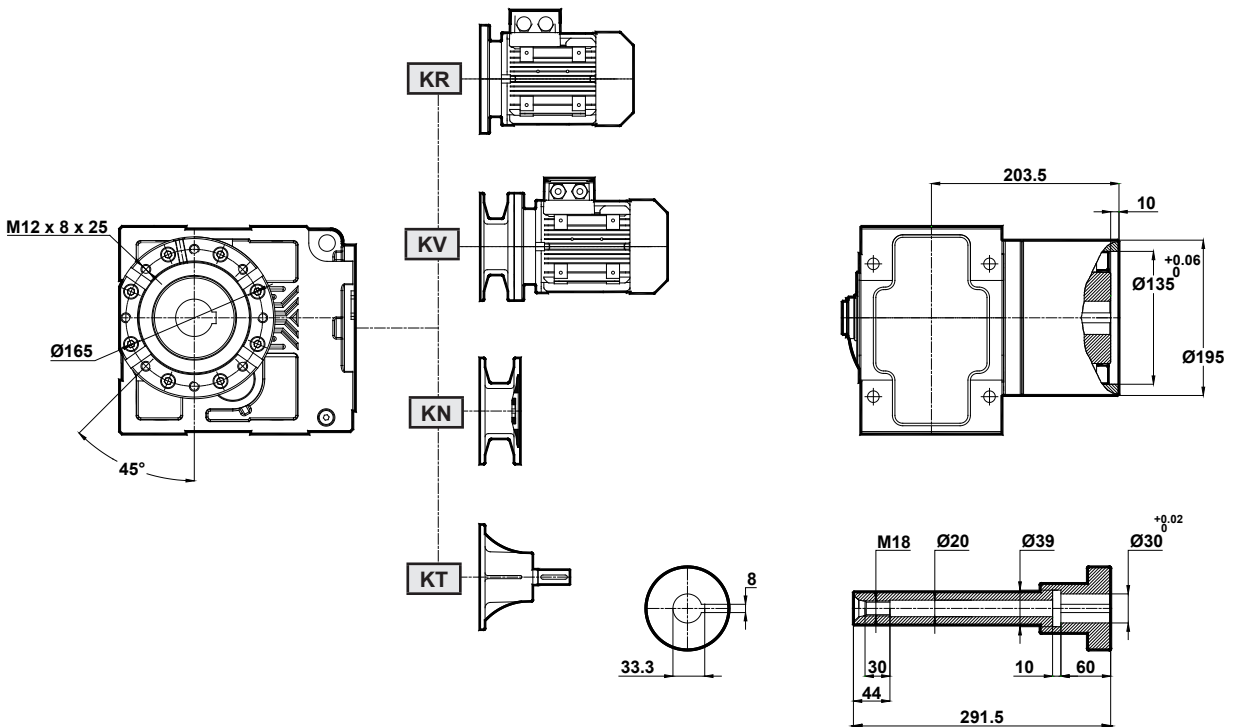

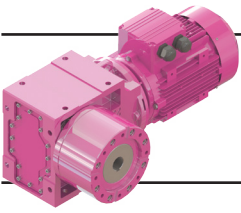

Ölçü Sayfaları

Dimension Pages
Abmessungenseiten

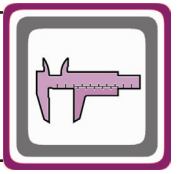

K.37.E

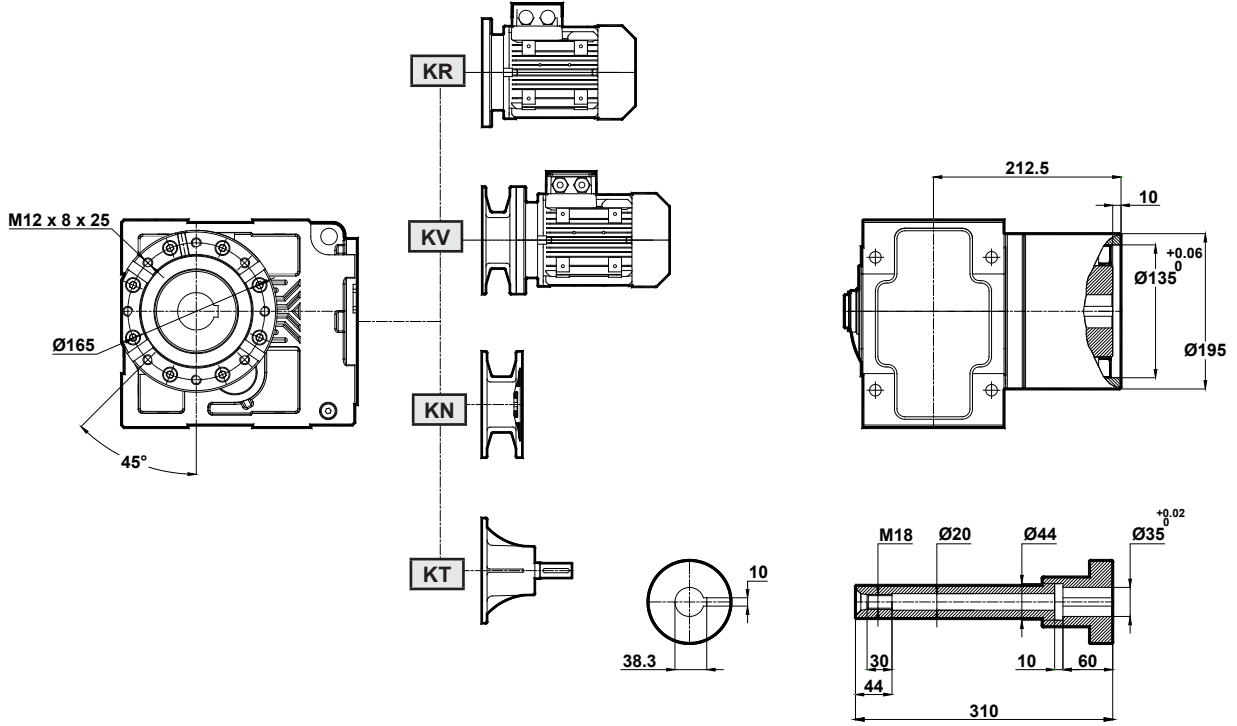

K.47.E

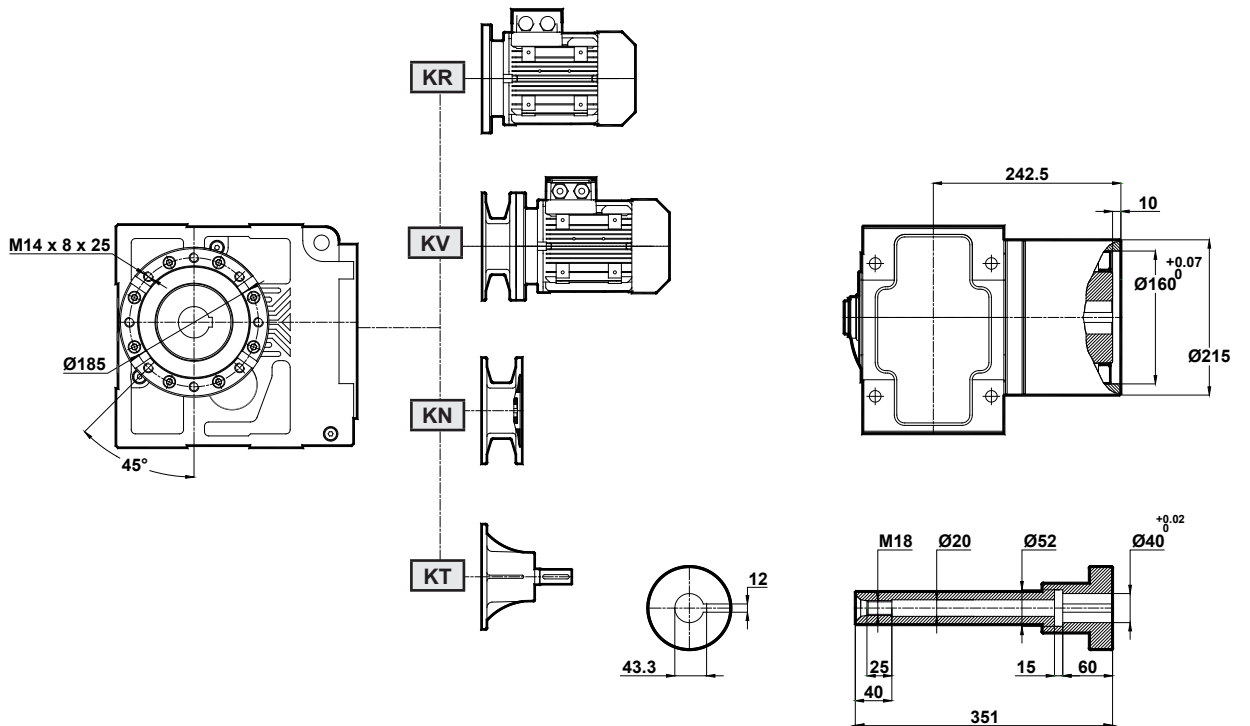

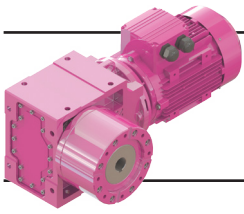

Ölçü Sayfaları

Dimension Pages
Abmessungenseiten

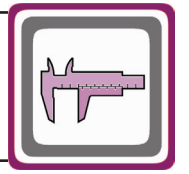

K.57.E

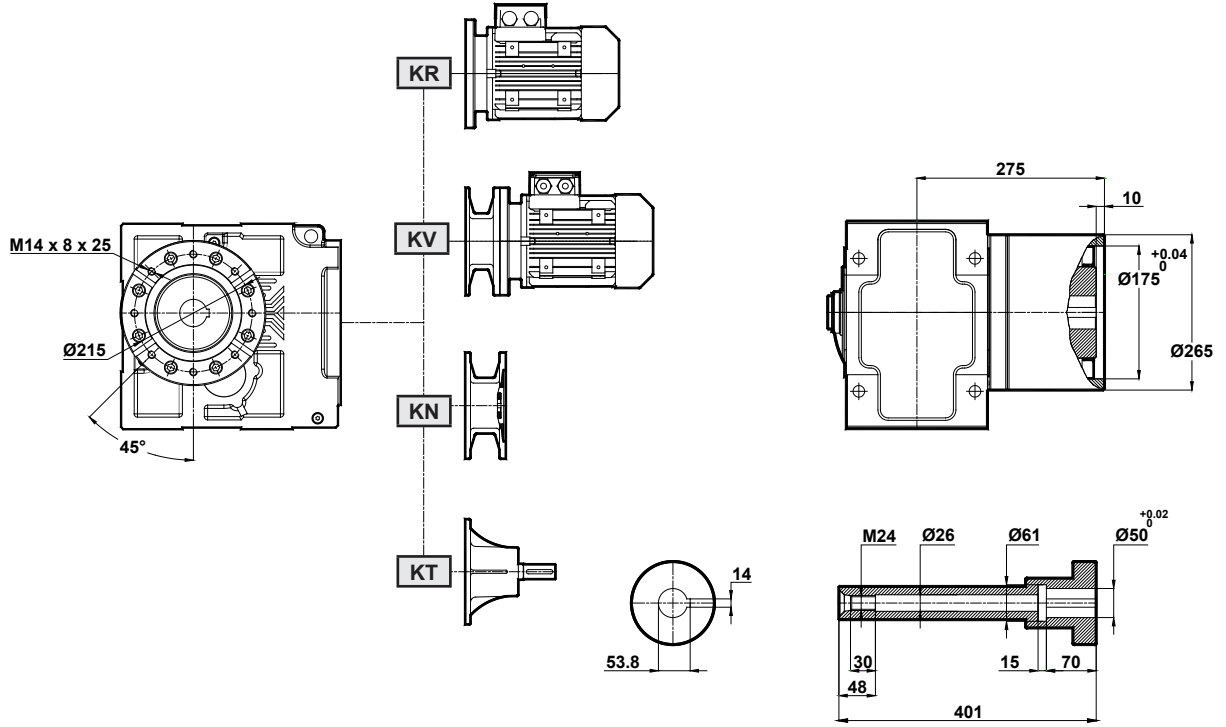

K.67.E

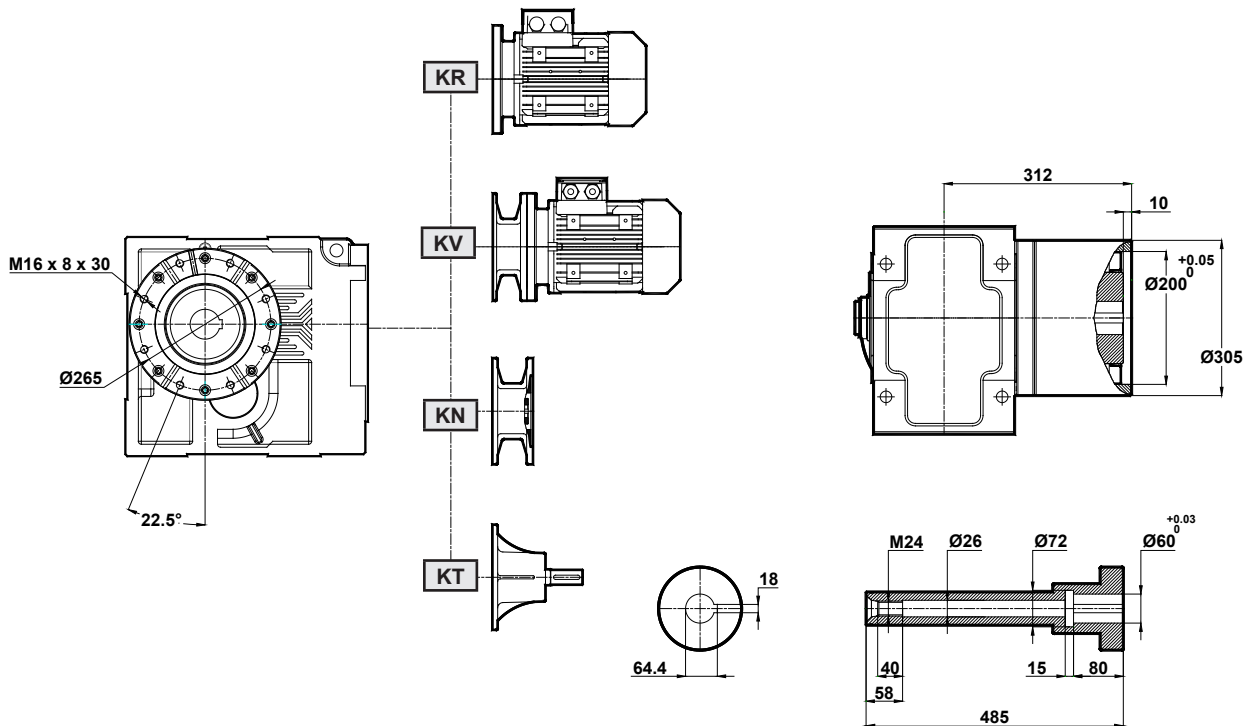

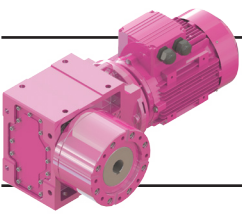

Ölçü Sayfaları

Dimension Pages
Abmessungenseiten

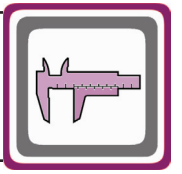

K.77.E

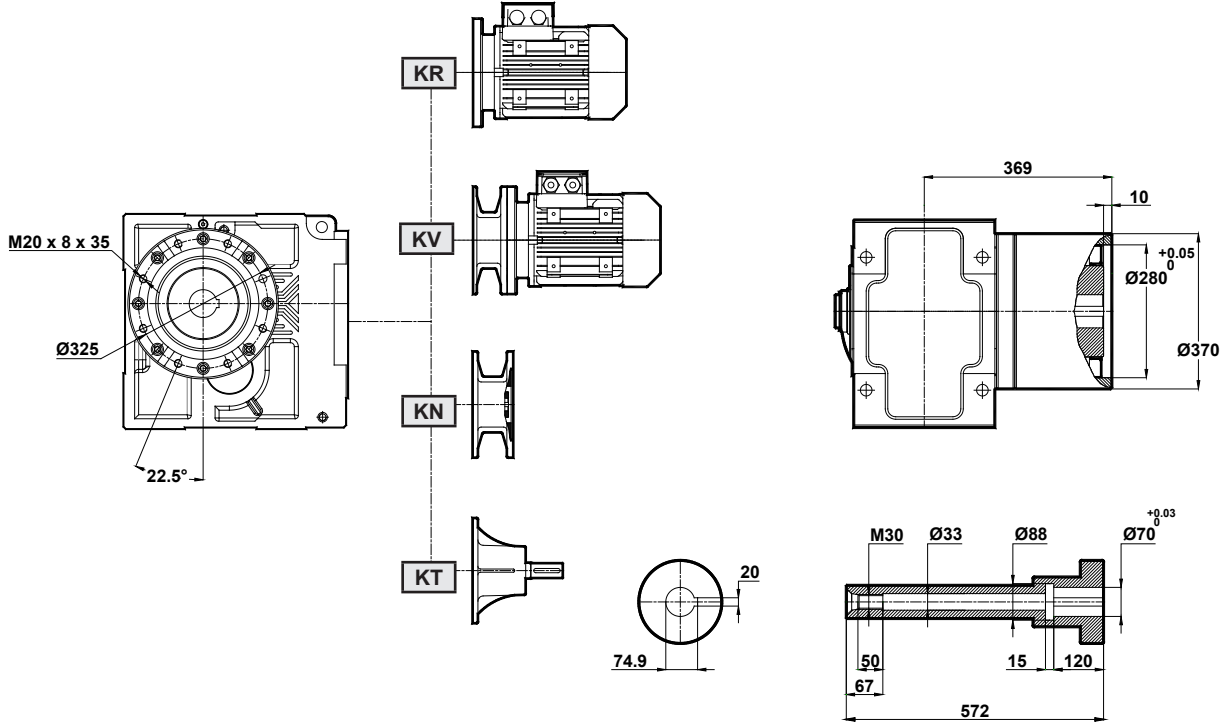

K.87.E

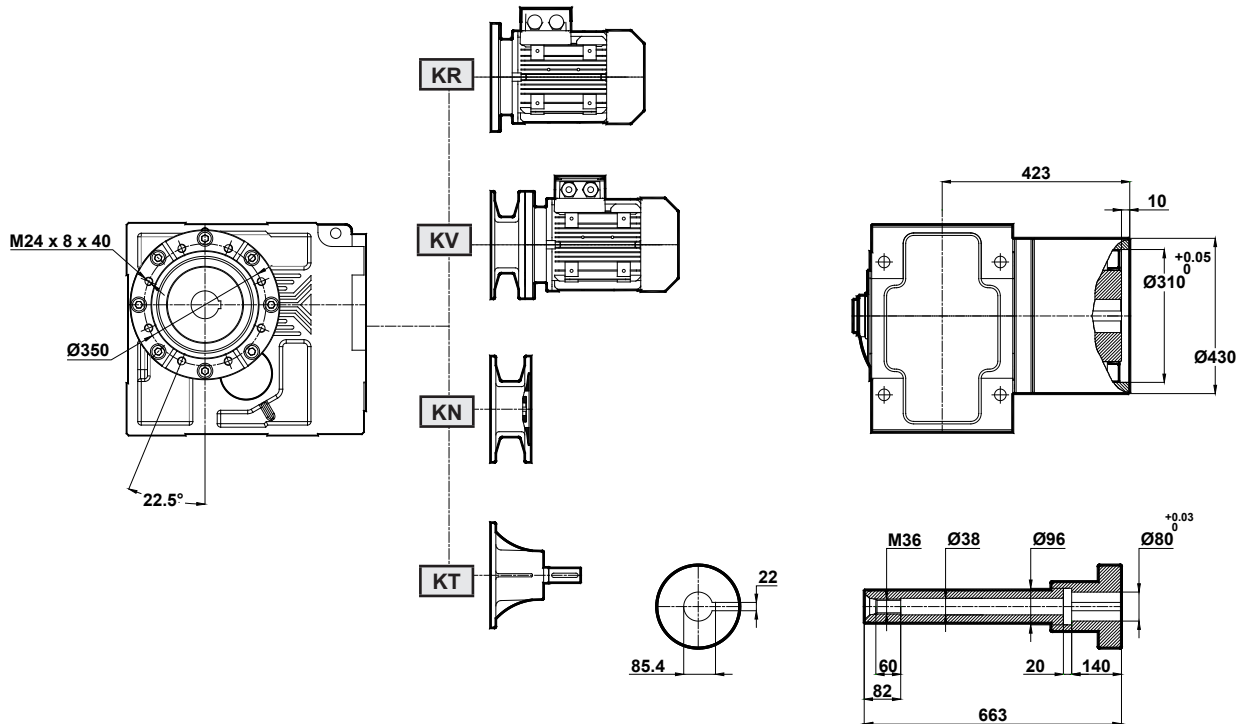

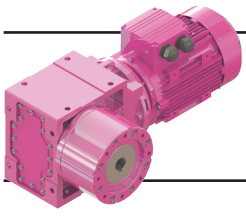

Ölçü Sayfaları
Dimension Pages
Abmessungenseiten

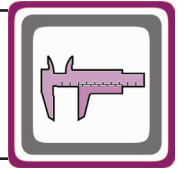

K.97.E

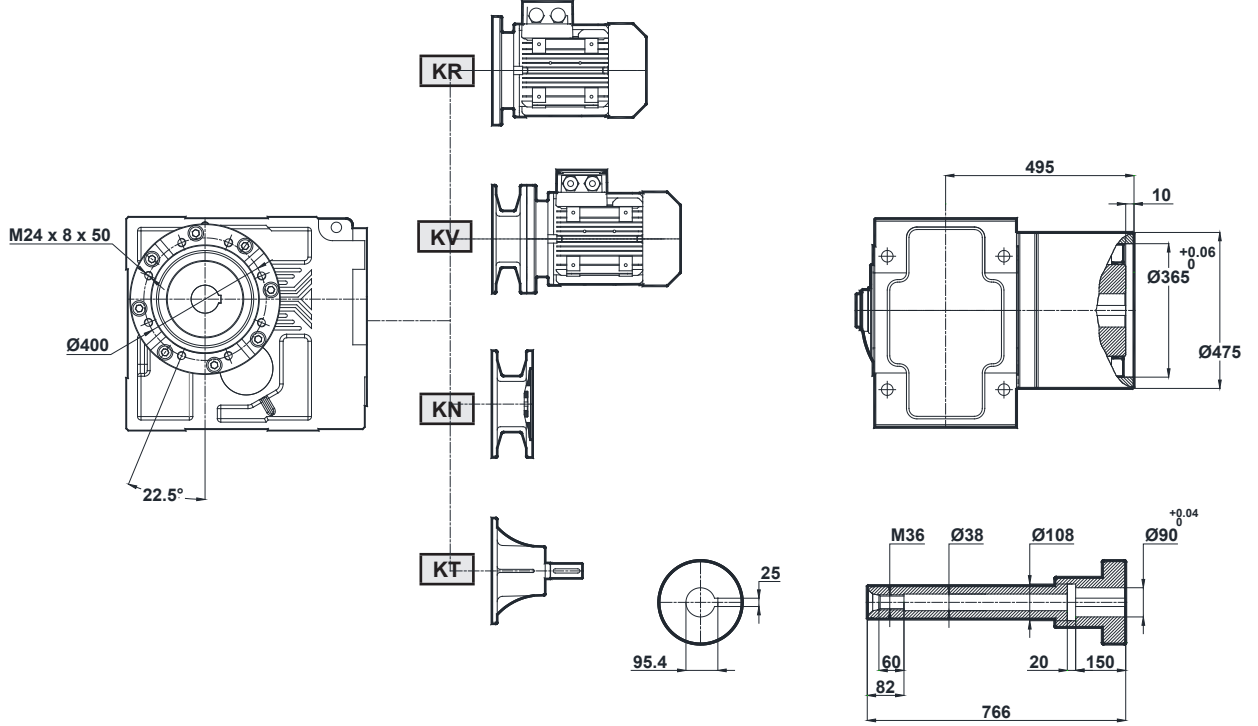

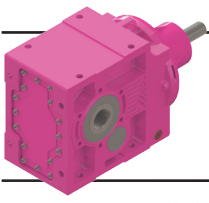

Ölçü Sayfaları Dimension Pages Abmessungsseiten

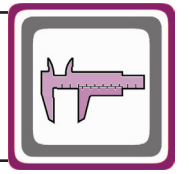

K SERİSİ REDÜKTÖRLERDE TAVSİYE EDİLEN MİL BOYU MONTAJ-DEMONTAJ ŞEKLİ VE AKSESUARLARI
ADVISED SHAFT DIMENSIONS AND ACCESORIES USED BY ASSEMBLING FOR K SERIES GEARBOXES
EMPFOHLENE WELLENABMESSUNGEN UND VERBINDUNGSELEMENTE BEI MONTAGE FÜR BAUREIHE K

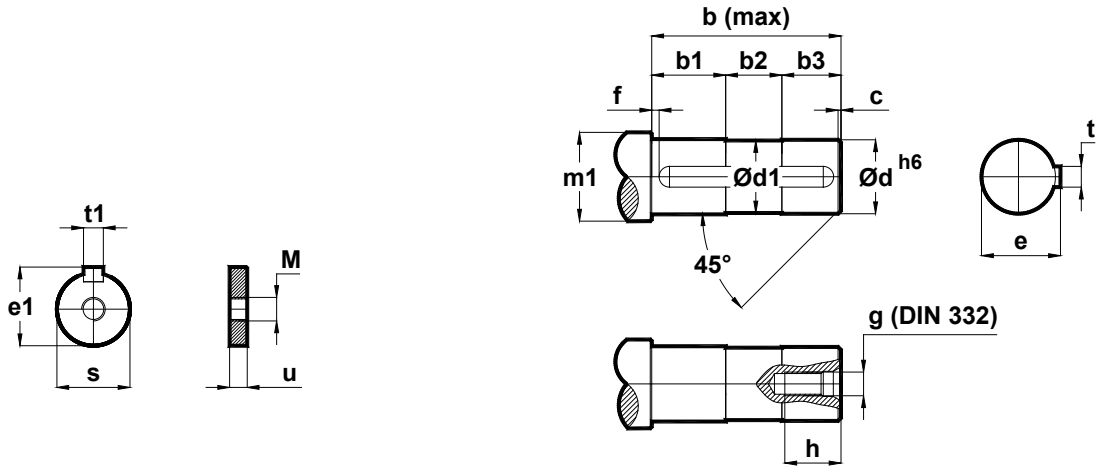

Tipi Type Typ	s	u	e1	t1	M	d	d1	m1	f	b	b1	b2	b3	c	g	h	e	t
K.00..	19.7	10	22	5.5	M10	20	19	24	5	86	45	25	16	0.5	M6	18	22.5	6
K.10..	29.7	10	33	7.5	M12	30	29	36		90	50	20	20	1	M10	24	33	8
K.20..	34.7	12	38	9.5	M16	35	34	43		102	60	20	22	1	M12	30	38	10
K.27..	34.7	12	38	9.5	M16	35	34	43		114	65	27	22	1	M12	30	38	10
K.28..	34.7	12	43	11.5	M20	40	39	50		124	70	28	26	2	M16	38	43	12
K.37..	39.7	12	43	11.5	M20	40	39	50		138	75	35	28	2	M16	38	43	12
K.47..	49.7	12	53.5	13.5	M20	50	49	60		165	87	41	37	3	M16	38	53.5	14
K.57..	59.7	16	64	17.5	M24	60	59	75		188	101	44	43	3	M20	44	64	18
K.67..	69.7	16	74.5	19.5	M24	70	69	85		248	115	78	55	4	M20	44	74.5	20
K.77..	89.7	20	95	24.5	M30	90	89	110		287	140	83	64	4	M24	52	95	25
K.87..	109.7	20	116	27.5	M30	110	109	130		347	165	98	84	4	M24	52	116	28
K.97..	119.7	20	127	31	M30	120	119	140		434	185	130	119	4	M24	52	127	32

Mil Çektirme / Shaft Mounting / Einziehen

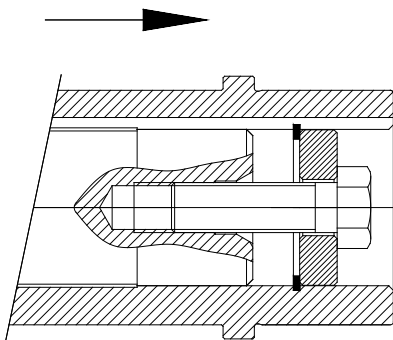

Mil Çıkartma / Shaft Pulling Out / Heraus Drücken

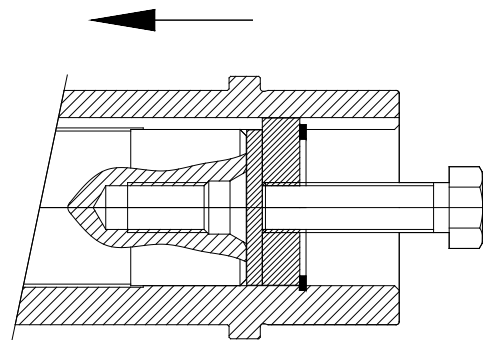

6 Köşe Başlı Civata / 6 Contour Bolt / Sechskantschraube
(DIN ISO 4014 . DIN ISO 4017)
(DIN ISO 8765)

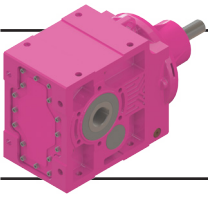

Ölçü Sayfaları

Dimension Pages

Abmessungsseiten



K SERİSİ REDÜKTÖR KOVAN ÖLÇÜLERİ

HOLLOW SHAFT DIMENSIONS FOR K SERIES GEARBOXES
HOHLWELLEABMESSUNGEN VON BAUREIHE K

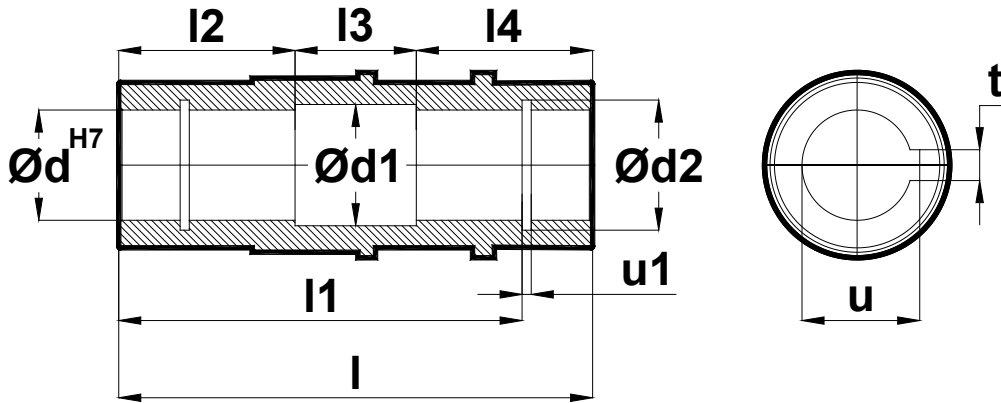

Tip Type Typ	d	d1	d2	l	l1	l2	l3	l4	u1	t	u
K.00..	20	21	21	115	100	40	35	40	1.1	6	22.8
K.10..	30	31	31.4	120	105	45	30	45	1.3	8	33.3
K.20..	35	36	36.4	140	120	55	30	55	1.6	8	38.3
K.27..	35	36	37	157	132	60	37	60	1.6	10	38.3
K.28..	40	41	42.5	166	142	64	38	64	1.85	12	43.3
K.37..	40	41	42.5	185	156	70	45	70	1.85	12	43.3
K.47..	50	51	53	215	183	82	51	82	2.15	14	53.8
K.57..	60	61	63	246	210	96	54	96	2.15	18	64.4
K.67..	70	71	73	308	270	110	88	110	2.65	20	74.9
K.77..	90	91	93.5	363	313	135	93	135	3.15	25	95.4
K.87..	110	111	114	428	373	160	108	160	4.15	28	116.4
K.97..	120	121	124	500	460	180	140	180	4.15	32	127.4

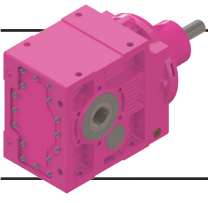

Ölçü Sayfaları Dimension Pages Abmessungsseiten

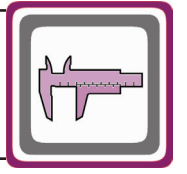

K SERİSİ DELİK MİLLİ SIKMA BİLEZİKLİ REDÜKTÖRLER K SERIES HOLLOW SHAFT WITH SHRINK DISC CONNECTOR HOHLWELLE MIT SCHRUMPFSCHEIBE FÜR BAUREIHE K

M x z Sıkma Civataları / Clamping Screws / Spanschrauben DIN EN ISO 4017 - 10.9

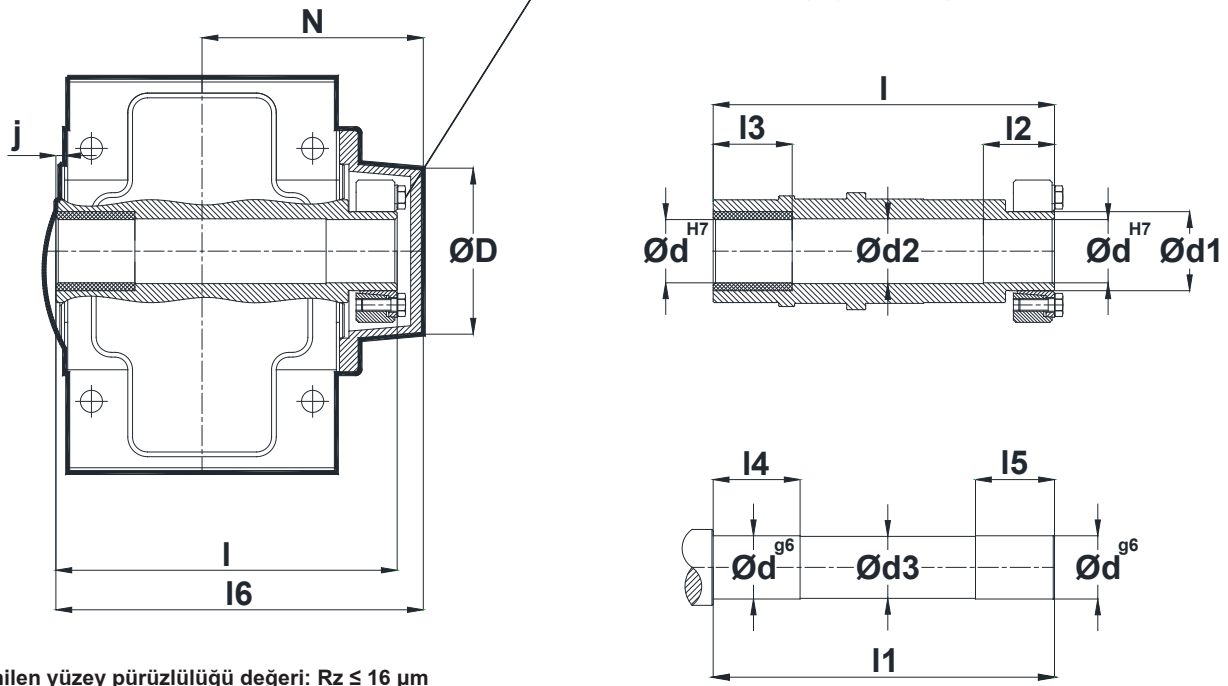

İstenilen yüzey pürüzlülüğü değeri: $Rz \leq 16 \mu m$
Desired surface roughness value: $Rz \leq 16 \mu m$
Gewünschtes Oberflächenrauheitswert: $Rz \leq 16 \mu m$

	ØD	Ød	Ød1	Ød2	Ød3	I	I1	I2	I3	I4	I5	I6	N	j	M x z	Ta [Nm]
K..00..0S	69	20	24	21	19	137	140	27	20	25	35	147	89.5	4	M5 x 6	4
K..10..0S	88	30	36	31	29	147	150	32	22	27	40	161	101	4	M6 x 5	12
K..20..0S	94	35	44	36	34	170	173	35	25	30	43	183	113	5	M6 x 7	12
K..27..0S	98	35	44	36	34	186	189	35	40	45	43	201	122.5	4.5	M6 x 7	12
K..28..0S	106	40	50	41	39	197	200	35	30	35	43	214	131	5	M6 x 8	12
K..37..0S	106	40	50	41	39	214	219	35	40	45	43	233	140.5	5.5	M6 x 8	12
K..47..0S	129	50	62	51	49	249	252	47,5	52,5	57,5	55,5	236.5	156	5.5	M6 x 10	12
K..57..0S	164	60	75	61	59	282	285	55	60	65	63	302.5	179.5	5.5	M8 x 7	30
K..67..0S	164	70	80	71	69	344	348	60	65	70	68	364	210	6	M8 x 7	30
K..77..0S	219	90	110	91	79	418	421	80	80	90	93	438.5	257	7.5	M10 x 9	59
K..87..0S	260	110	140	111	109	492	495	85	90	100	98	517	303	9	M12 x 10	100
K..97..0S	288	120	155	121	119	570	573	90	80	90	103	595	345	5	M12 x 12	100

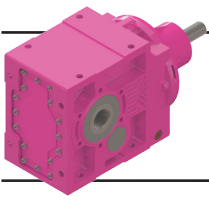

Ölçü Sayfaları

Dimension Pages

Abmessungsseiten

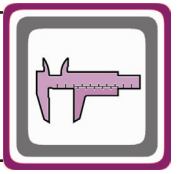

K.27.. - K.97.. MOMENT KOLU BAĞLANTI DETAYI

K.27.. - K.97.. TORQUE ARM ASSEMBLY DETAILS

K.27.. - K.97.. DREHMOMENTSTÜTZE MONTAGEZEICHNUNGEN

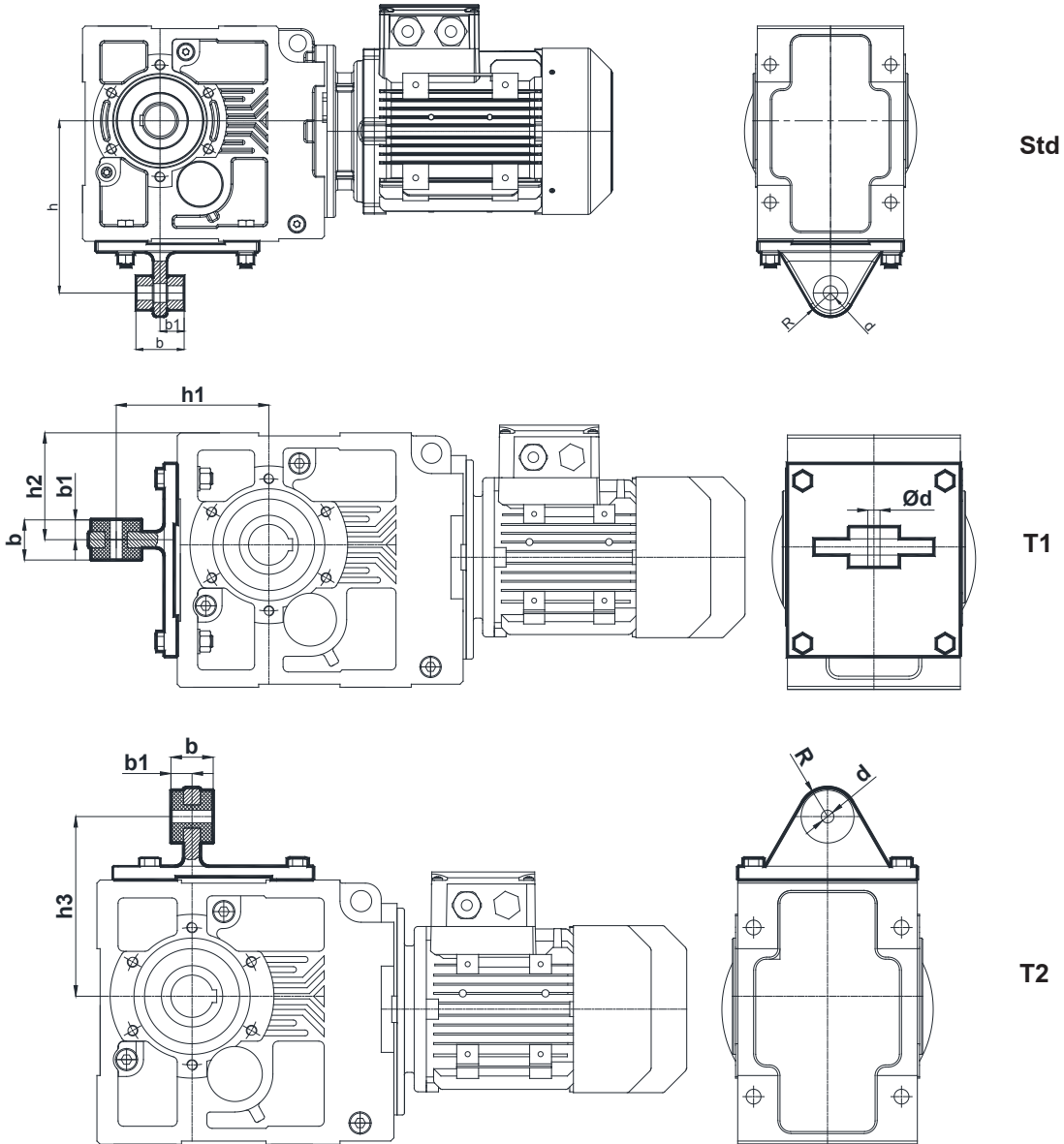

Tip	b	b1	d	R	Std	T1		T2
					h	h1	h2	h3
KR273.10	56	28	Ø17	22,5	160	119	73	141
KR283.10	76	38	Ø22	27,5	192	140	77	150
KR373.10	76	38	Ø22	27,5	200	150	105	170
KR473.10	80	40	Ø22	27,5	250	182	155	210
KR573.10	105	52,5	Ø26	42,5	300	220	180	251
KR673.10	110	55	Ø26	42,5	350	245	200	260
KR773.10	155	77,5	Ø32	50	450	335	260	360
KR873.10	160	80	Ø32	55	550	400	263	410
KR973.10	190	95	Ø38	70	700	530	380	550

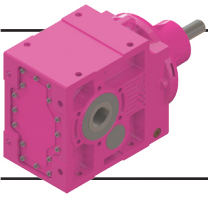

Ölçü Sayfaları

Dimension Pages

Abmessungsseiten

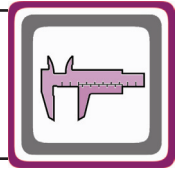

K.00.. - K.20.. MOMENT KOLU BAĞLANTI DETAYI

K.00.. - K.20.. TORQUE ARM ASSEMBLY DETAILS

K.00.. - K.20.. DREHMOMENTSTÜTZE MONTAGEZEICHNUNGEN

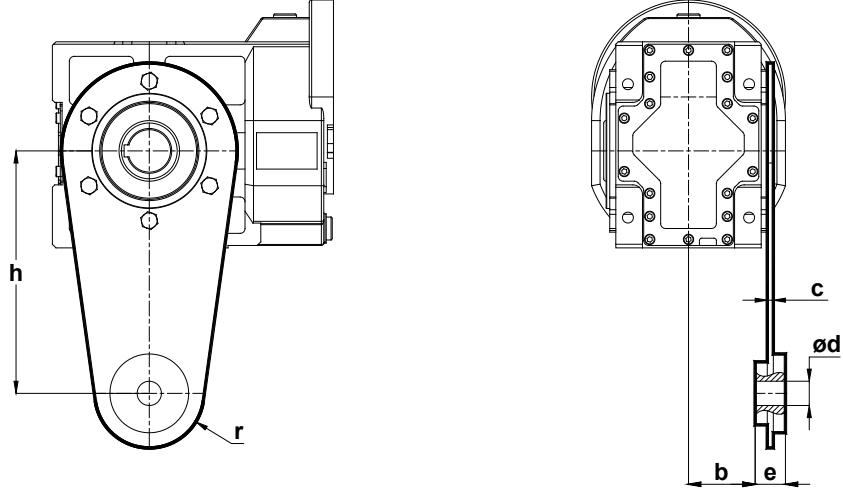

Tip	b	e	d	r	h	c
K.00..	47	16	Ø10	32	100	3
K.10..	49.5	16	Ø10	36	150	3
K.20..	54.5	25	Ø20	45	200	5

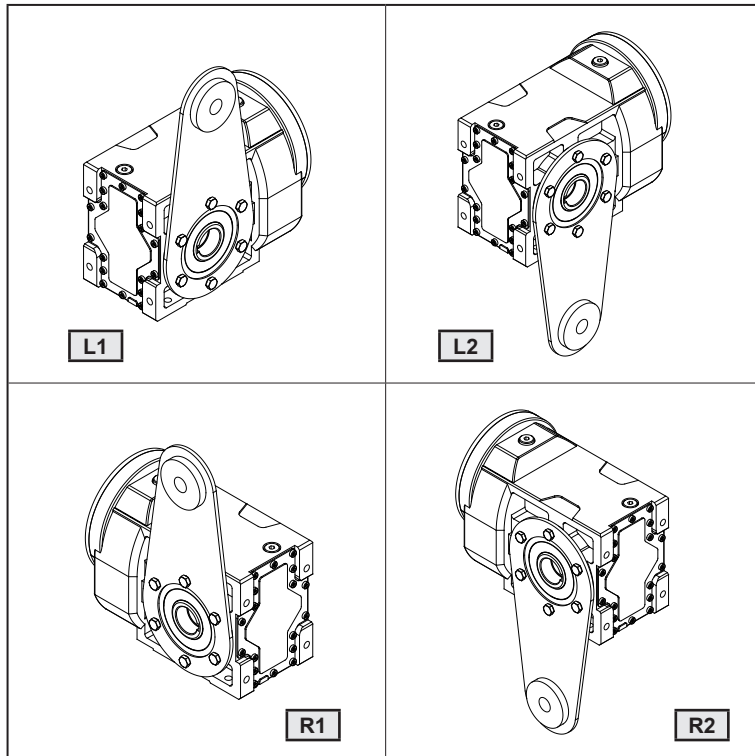

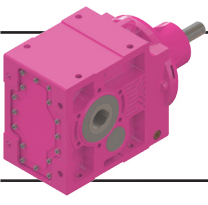

Ölçü Sayfaları Dimension Pages Abmessungsseiten



K.27.. - K.97.. OPSİYONEL MOMENT KOLU BAĞLANTI DETAYI K.27.. - K.97.. OPTIONAL TORQUE ARM ASSEMBLY DETAILS K.27.. - K.97.. AUSWÄHLBARE DREHMOMENTSTÜTZE MONTAGEZEICHNUNGEN

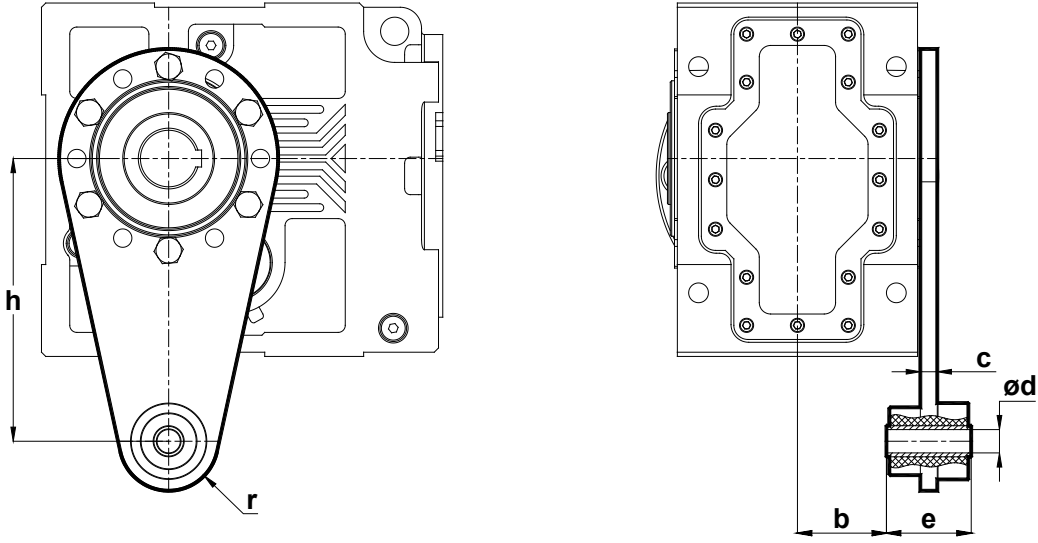

Tip Type Typ	b	e	ød	r	h	c
K.273	62	36	ø11	25	160	12
K.283	63	60	ø16,5	35	200	12
K.373	63	60	ø16,5	35	200	12
K.473	78	60	ø16,5	35	250	12
K.573	73,5	100	ø25	48	300	12
K.673	105,5	100	ø25	54	380	15
K.773	131,5	100	ø25	58	450	15
K.873	155	120	ø32	70	550	20
K.973	195	120	ø38	75	700	20

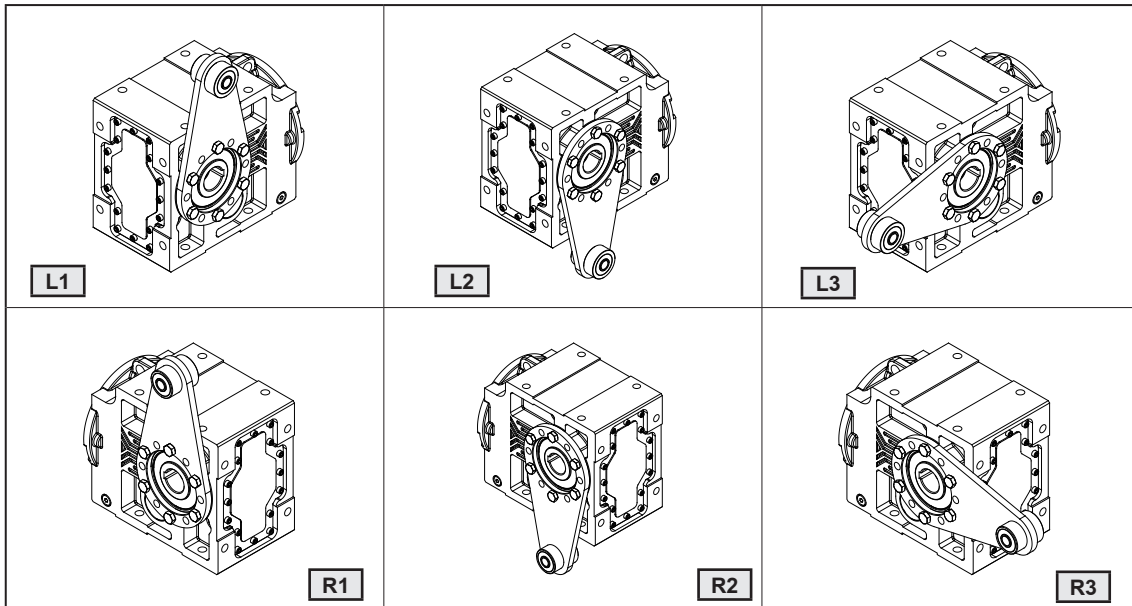

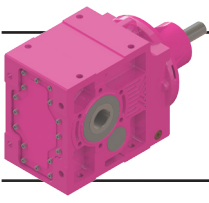

Ölçü Sayfaları

Dimension Pages

Abmessungsseiten

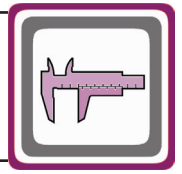

K.00.. - K.97.. DIN 5480 ÇOKLU KAMA ÖLÇÜLERİ

K.00.. - K.97.. DIMENSIONS OF SPLINED HOLLOW SHAFT TO DIN 5480

K.00.. - K.97.. ABMESSUNGEN VON HOHLWELLE MIT VIELKEILVERZÄHNUNG NACH DIN 5480

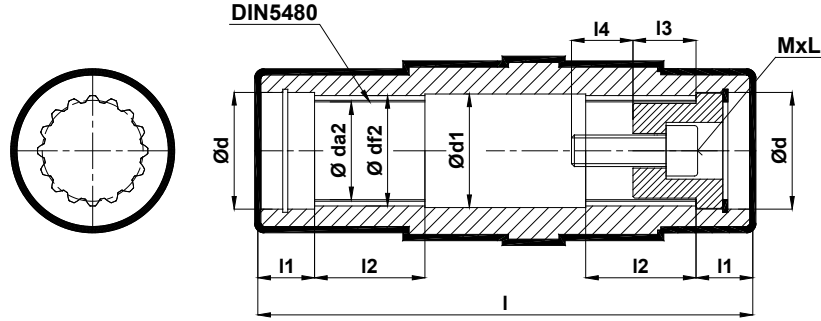

Tip Type Typ	DIN5480	ød	ød1	ød2	øda2	ødf2	l	l1	l2	l3	l4	MxL
K00	N25x1,25x30x18x9H	27	26	44	22,5	25,25	115	17	22	20	20	M10x60
K10	N30x1,25x30x22x9H	32	31	53	27,5	30,25	120	18	25	20	20	M10x60
K20 K27 K28	N35x2x30x16x9H	37	36	64 58 63,5	31	35,4	140 157 166	18	35	20	20	M10x70 M10x90 M10x100
K37	N45x2x30x21x9H	47	46	74	41	45,4	185	25	45	24	32	M16x110
K47	N50x2x30x24x9H	55	51	84	46	50,4	215	25	55	24	32	M16x130
K57	N65x2x30x31x9H	72	66	104	61	65,4	246	25	65	30	40	M20x150
K67	N70x2x30x34x9H	72	71	119	66	70,4	308	25	75	30	40	M20x210
K77	N85x3x30x27x9H	90	86	139,5	79	85,6	363	26	90	30	40	M20x240
K87	N100x4x30x24x9H	110	101	169	92	100,8	428	30	105	41	50	M24x290
K97	N120x4x30x28x9H	130	121	179	112	120,8	500	35	120	41	50	M24x340

NOT: Makina mil boyu tek taraflı çoklu kama uzunluk ölçüsüne (l1+l2) göre yapılmalıdır! Delik mil boydan boya kullanılamaz!
NOTE: The customer shaft length must be made only for one sided (l1+l2) splined hollow shaft dimensions! The total length (l) of the splined hollow shaft can not be used in this case!

HINWEIS: Die Kundenwellenlänge muss nur für einseitig (l1+l2) Hohlwelle mit Vielkeilverzahnung gefertigt werden. Die Gesamtlänge der Hohlwelle (l) kann in diesem Fall nicht verwendet werden!

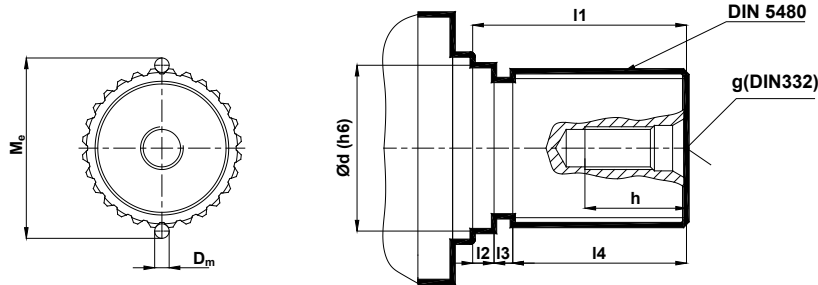

Tip Type Typ	DIN5480	ød	l1	l2	l3	l4	Me	Dm	g (DIN332)
K00	W25x1,25x30x18x8f	27	44	10	7	27	28,01 ⁰ / -0,03	2,75	M10x24
K10	W30x1,25x30x22x8f	32	48	11	7	30	33,05 ⁰ / -0,04	2,75	M10x24
K20 K27 K28	W35x2x30x16x8f	37	58	11	7	40	38,94 ⁰ / -0,05	4,00	M10x24
K37	W45x2x30x21x8f	47	75	18	7	50	48,88 ⁰ / -0,05	4,00	M16x38
K47	W50x2x30x24x8f	55	85	18	7	60	54,16 ⁰ / -0,05	4,00	M16x38
K57	W65x2x30x31x8f	72	95	17	8	70	68,99 ⁰ / -0,06	4,00	M20x44
K67	W70x2x30x34x8f	72	105	17	8	80	74,18 ⁰ / -0,06	4,00	M20x44
K77	W85x3x30x27x8f	90	121	16	10	95	91,02 ⁰ / -0,05	6,00	M20x44
K87	W100x4x30x24x8f	110	140	20	10	110	108,37 ⁰ / -0,06	8,00	M24x52
K97	W120x4x30x28x8f	130	160	23	12	125	127,89 ⁰ / -0,06	8,00	M24x52

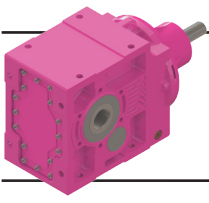

Ölçü Sayfaları Dimension Pages Abmessungsseiten

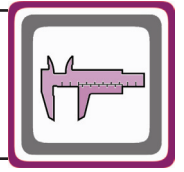

K SERİSİ OPSİYONEL ÇIKIŞ FLANŞ ÖLÇÜLERİ OPTIONAL OUTPUT FLANGE DIMENSIONS FOR K SERIES AUSWÄHLBARE ABTRIEBSFLANGEDIMENSIONEN FÜR BAUREIHE K

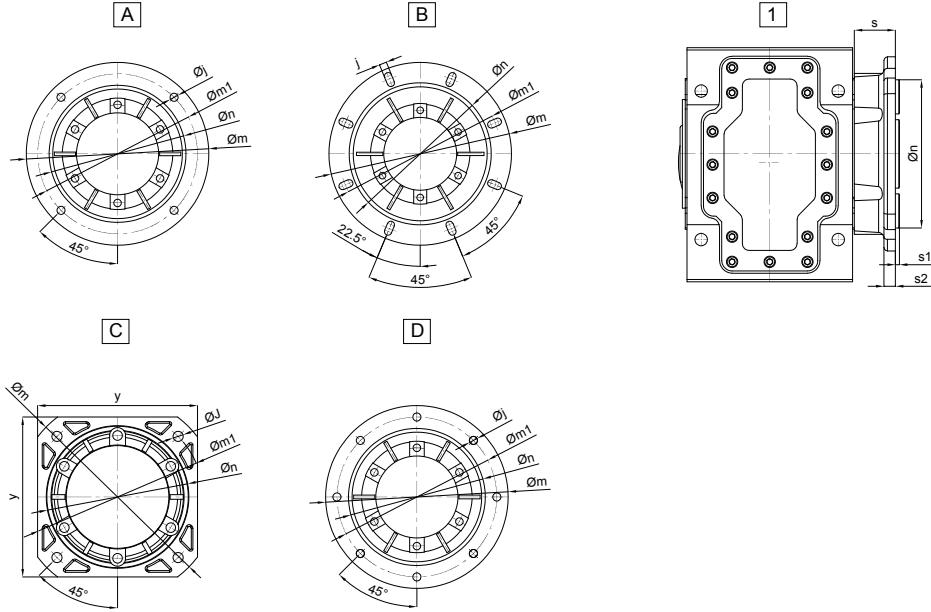

Tip Type Typ	Flanş Kodu Flange Code Flanschkode	Flanş Tipi Flange Type Flanschtyp	Montaj Ölçüleri Mounting Dimensions Montageabmessungen							
			Øm	Øm1	Øn	j	s	s1	s2	y
K003	MX05.5K003-120	C1	120	95	80	8	46,5	3	9	110x110
K103	DX05.5D173-200	A1	200	165	130	12	28	3,5	12	-
K203 K273	MX05.K273-160X01	A1	160	130	110	12	54	3,5	13	-
	MX05.5K273-250	C1	250	215	180	14	42	4	14	210x210
K283 K373	MX05.5K373-250X05	A1	250	215	180	Ø14	86	4	15	-
	MX05.5K373-300	C1	300	265	230	14	46	4	16	240x240
	DX05.5D283-200	A1	250	215	180	Ø14	40	4	15	-
	DX05.5D283-250	A1	200	165	130	12	30	4	19	-
K473	DX05.5D373-300	A1	300	265	230	Ø14	40,5	4	15	-
	MX05.5K473-250	A1	250	215	180	14	28	4	16	-
K473	MX05.5K473-350	A1	350	300	250	Ø18	46,5	4	18	-
	MX05.5K573X08	C1	350	300	250	Ø18	78	5	18	280x280
K573 K673	MX05.5K573-300	A1	300	265	230	M12	30	4	20	-
	MX05.5K673-450	B1	450	400	350	18	62	5	22	-
	DX05.5D573-400	D1	400	350	300	Ø18	55	5	20	-
	DX05.5D673-450	D1	450	400	350	Ø18	54,5	5	20	-
K773	MX05.5K773-400	B1	400	350	300	Ø18	77	5	24	-
K873	MX05.5K873-450	B1	450	400	350	Ø18	99	5	26	-
	MX05.5K873-550X01	B1	550	500	450	18	51	5	25	-

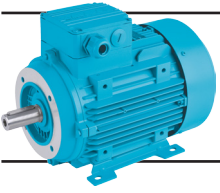

Elektrik Motorlarının Performans Deęerleri

*Electric Motors
Ratings and Performance*

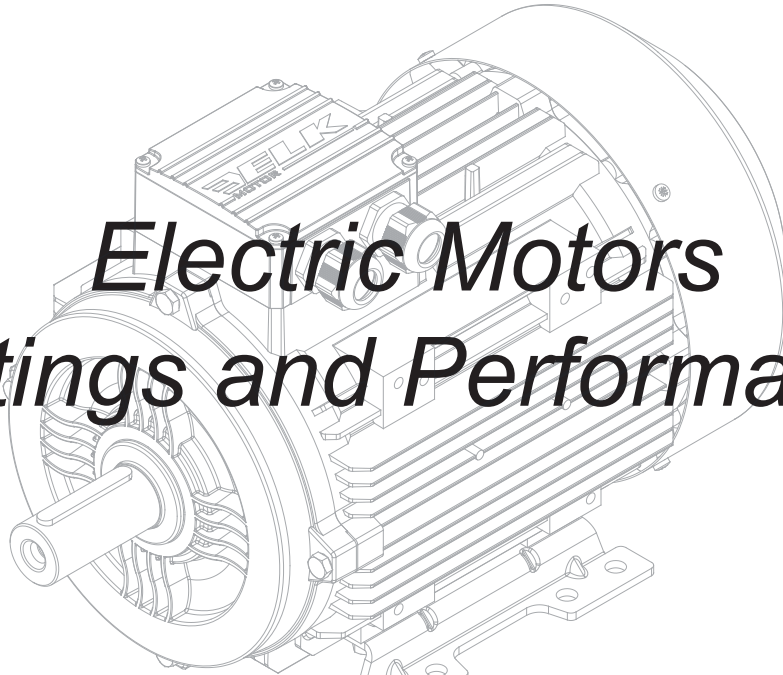

**Elektromotoren
Leistungsdaten**

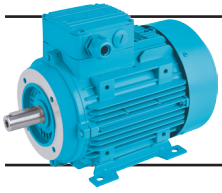

Elektrik Motorlarının Performans Değerleri

Electric Motors Ratings and Performance

Elektromotoren Leistungsdaten



400V 50Hz 3000 d/d / 400V 50Hz 3000 rpm / 400V 50Hz 3000 UpM

IE3

Tip Type Typ	Tam Yük Değerleri Full-load Data Vollastdaten								Kalkış Değerleri Starting Data Startdaten		Devrilme Momenti Breakdown Torque Kippmoment	Atalet Momenti Moment of Inertia Trägheits- moment	B3 Motor Ağırlığı B3 Motor Gewicht	Ses Seviyesi Noise Level Geräusch- pegel
	Güç	Devir	Akım	Moment	Güç Faktörü	Verim % η			Akım	Moment				
	Power	Speed	Current	Torque	Power Factor	Efficiency % η			Current	Torque				
	Leistung	Drehzahl	Nennstrom	Drehmoment	Leistungsfaktor	Wirkungsgrad % η			Nennstrom	Drehmoment				
	kW	d/d rpm UpM	A	Nm	cos ϕ	4 / 4	3 / 4	1 / 2	I_A/I_N	M_A/M_N	M_K/M_N	kgm ²	kg	dB(A)
3E71M/2B	0,37	2830	0,86	1,25	0,81	76,6	77,0	75,0	6,0	2,8	3,0	0,00037	6,2	53
3E71M/2C	0,55	2830	1,19	1,86	0,84	79,4	80,2	78,8	6,1	2,9	3,3	0,00046	7,2	53
3E80M/2B	0,75	2880	1,59	2,49	0,84	80,7	82,0	81,5	6,7	3,0	3,6	0,00103	9,6	54
3E80M/2C	1,1	2880	2,26	3,64	0,85	82,7	83,0	82,4	6,8	3,1	3,8	0,00124	10,9	54
3E90S/2B	1,5	2900	2,97	4,94	0,86	84,8	85,4	84,2	7,6	3,1	3,9	0,00178	15,6	59
3E90L/2C	2,2	2900	4,25	7,24	0,87	85,9	86,8	86,1	7,2	3,0	3,8	0,00221	17,0	59
3E100L/2C	3	2915	5,58	9,83	0,89	87,1	87,6	86,9	7,9	3,0	4,1	0,00450	23,3	62
3E112M/2C	4	2915	7,28	13,1	0,90	88,1	88,8	88,2	7,5	2,6	3,9	0,00620	29,1	65
3E132S/2B	5,5	2945	9,9	17,83	0,90	89,2	89,0	88,6	8,9	2,9	3,9	0,01730	44,4	67
3E132S/2C	7,5	2945	13,2	24,32	0,91	90,1	90,5	89,7	8,4	2,6	4,0	0,02100	51,5	67
3E160M/2B	11	2950	19,7	35,6	0,88	91,2	91,0	90,5	8,0	2,6	3,9	0,03320	114	69
3E160M/2C	15	2950	25,9	48,55	0,91	91,9	92,1	91,6	8,9	3,1	4,2	0,03910	131	69
3E160L/2D	18,5	2945	31,7	60,00	0,91	92,4	92,7	92,3	8,9	3,1	4,2	0,04410	135	69
3E180M/2B	22	2957	38,1	71,05	0,90	92,7	92,9	92,0	8,6	2,6	3,9	0,06300	178	70
3E200L/2B	30	2970	52	96,46	0,89	93,6	93,8	93,6	8,9	3,2	3,5	0,16200	245	72
3E200L/2C	37	2970	62,6	119	0,91	93,7	93,8	93,4	9,3	3,2	3,4	0,17500	270	72
3E225M/2C	45	2975	75,6	144,4	0,91	94,3	94,6	94,0	9,8	3,5	3,9	0,25400	380	74
3E250M/2C	55	2970	93,3	176,9	0,90	94,4	94,8	94,5	8,9	3,3	3,4	0,38000	480	75
3G280S/2	75	2985	127	240	0,90	94,7	94,6	94,0	8,0	2,9	3,2	0,62000	585	76
3G280M/2	90	2985	148	288	0,92	95,0	95,0	93,7	8,2	2,9	3,0	0,74000	645	76
3G315S/2	110	2985	186	353	0,90	95,2	95,2	94,0	8,0	2,5	3,0	1,20000	742	76
3G315M/2a	132	2985	223	423	0,90	95,4	95,4	94,1	8,0	2,4	3,5	1,40000	812	79
3G315M/2b	160	2985	265	513	0,91	95,6	95,6	94,2	8,0	2,5	3,0	1,50000	912	79

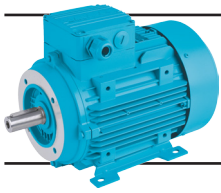

Elektrik Motorlarının Performans Değerleri

Electric Motors Ratings and Performance

Elektromotoren Leistungsdaten



400V 50Hz 1500 d/d / 400V 50Hz 1500 rpm / 400V 50Hz 1500 UpM

IE3

Tip Type Typ	Tam Yük Değerleri Full-load Data Volllastdaten							Kalkış Değerleri Starting Data Startdaten			Devrilme Momenti Breakdown Torque Kippmoment	Atalet Momenti Moment of Inertia Trägheitsmoment	B3 Motor Ağırlığı B3 Motor Weight B3 Motor Gewicht	Ses Seviyesi Noise Level Geräuschpegel
	Güç	Devir	Akım	Moment	Güç Faktörü	Verim % η			Akım	Moment				
	Power	Speed	Current	Torque	Power Factor	Efficiency % η			Current	Torque				
	Leistung	Drehzahl	Nennstrom	Drehmoment	Leistungsfaktor	Wirkungsgrad % η			Nennstrom	Drehmoment				
	kW	d/d rpm UpM	A	Nm	cos ϕ	4 / 4	3 / 4	1 / 2	I_A/I_N	M_A/M_N	M_K/M_N	kgm ²	kg	dB(A)
3E71M/4C	0,25	1435	0,67	1,66	0,71	76,0	75,4	71,5	5,4	2,2	3,0	0,00082	6,8	45
3E71M/4D	0,37	1435	0,97	2,46	0,70	78,5	78,2	75,0	5,5	2,2	3,1	0,00093	7,5	45
3E80M/4C	0,55	1450	1,34	3,62	0,73	80,8	80,4	77,0	5,9	2,1	3,1	0,00200	10,5	50
3E80M/4D	0,75	1450	1,77	4,94	0,74	82,5	82,3	80,0	6,2	2,5	3,4	0,00227	11,6	50
3E90S/4C	1,1	1450	2,46	7,25	0,76	84,5	84,3	82,0	7,0	2,6	3,6	0,00355	16,3	51
3E90L/4D	1,5	1450	3,3	9,88	0,77	85,3	85,2	83,0	7,2	2,8	3,8	0,00410	18,0	51
3E100L/4C	2,2	1450	4,65	14,49	0,79	86,7	87,2	86,0	7,2	2,8	3,6	0,00780	24,4	53
3E100L/4D	3	1450	6,26	19,76	0,79	87,7	88,0	87,0	7,2	2,8	3,6	0,00890	26,7	53
3E112M/4D	4	1460	8,05	26,16	0,81	88,6	88,4	87,5	7,4	2,8	3,8	0,01430	33,9	58
3E132S/4C	5,5	1460	10,65	36	0,83	89,6	90,2	90,0	7,4	2,8	3,4	0,03060	53,4	61
3E132M/4D	7,5	1465	14,4	48,9	0,83	90,4	90,4	89,4	7,9	3,0	3,8	0,03420	59,5	61
3E160M/4C	11	1470	21	71,46	0,83	91,5	92,1	91,7	7,6	2,8	3,3	0,07010	127	63
3E160L/4E	15	1470	28,7	97,45	0,82	92,1	92,4	91,9	7,8	2,8	3,6	0,08600	136	63
3E180M/4C	18,5	1475	35,0	119,8	0,82	92,6	93,2	92,9	7,7	3,0	3,3	0,12900	173	64
3E180L/4D	22	1470	41,4	142,92	0,82	93,0	93,7	93,7	8,0	3,0	3,4	0,14700	187	64
3E200L/4D	30	1475	54,5	194,20	0,85	93,6	94,1	94,0	8,0	3,0	3,4	0,28400	258	65
3E225S/4C	37	1478	65,7	239	0,87	93,9	94,5	94,5	8,3	3,2	3,3	0,38200	320	66
3E225M/4D	45	1477	80	290,9	0,86	94,2	94,7	94,7	8,6	3,3	3,2	0,44100	352	67
3E250M/4D	55	1482	95,3	354,4	0,88	94,6	95,1	95,2	8,7	3,3	3,2	0,73400	470	68
3G280S/4	75	1485	133	482	0,86	95,0	94,9	94,4	7,6	2,9	3,0	1,11000	605	67
3G280M/4	90	1485	158	579	0,86	95,2	95,2	94,8	7,4	2,9	3,0	1,32000	665	67
3G315S/4	110	1487	194	707	0,86	95,4	95,2	95,0	7,4	2,4	3,0	2,5000	861	74
3G315M/4a	132	1487	230	848	0,87	95,6	95,4	95,3	7,4	2,4	3,0	2,8000	882	74
3G315M/4b	160	1488	275	1027	0,88	95,8	95,6	95,6	6,9	2,2	2,9	3,0000	930	74

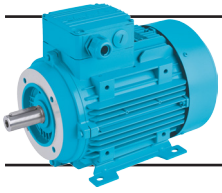

Elektrik Motorlarının Performans Değerleri

Electric Motors Ratings and Performance

Elektromotoren Leistungsdaten



400V 50Hz 1000 d/d / 400V 50Hz 1000 rpm / 400V 50Hz 1000 UpM

IE3

Tip Type Typ	Tam Yük Değerleri Full-load Data Vollastdaten								Kalkış Değerleri Starting Data Startdaten		Devrilme Momenti Breakdown Torque Kippmoment	Atalet Momenti Moment of Inertia Trägheitsmoment	B3 Motor Ağırlığı B3 Motor Weight B3 Motor Gewicht	Ses Seviyesi Noise Level Geräuschpegel
	Güç Power Leistung	Devir Speed Drehzahl	Akım Current Nennstrom	Moment Torque Drehmoment	Güç Faktörü Power Factor Leistungsfaktor	Verim % η Efficiency % η Wirkungsgrad % η			Akım Current Nennstrom	Moment Torque Drehmoment				
	kW	d/d rpm UpM	A	Nm	cos ϕ	4 / 4	3 / 4	1 / 2	I_A/I_N	M_A/M_N				
3E71M/6C	0,18	930	0,55	1,85	0,69	68,0	67,4	62,6	3,6	2,0	2,4	0,00096	6,7	41
3E71M/6D	0,25	930	0,77	2,57	0,67	70,0	69,7	66,0	3,6	2,2	2,5	0,00116	7,5	41
3E80M/6B	0,37	930	1,03	3,8	0,70	74,0	73,8	70,0	4,4	2,1	2,6	0,00202	9,8	43
3E80M/6C	0,55	935	1,47	5,62	0,70	77,2	77,3	74,4	4,3	2,2	2,7	0,00228	10,6	43
3E90S/6B	0,75	945	1,96	7,58	0,70	78,9	79,2	77,6	4,7	2,2	2,7	0,00354	14,6	46
3E90L/6C	1,1	940	2,75	11,2	0,71	81,0	80,8	79,4	5,0	2,2	2,7	0,00428	17,0	46
3E100L/6B	1,5	955	3,5	15	0,75	82,5	82,7	81,4	5,3	2,1	2,8	0,00820	22,5	50
3E112M/6B	2,2	965	4,95	21,7	0,76	84,3	84,5	83,5	5,5	2,2	3,0	0,01320	27,2	56
3E132S/6B	3	970	6,55	29,4	0,77	85,6	85,5	84,5	6,2	2,1	3,0	0,03050	46,5	58
3E132M/6C	4	970	8,52	39,4	0,78	86,8	87,0	85,5	6,2	2,2	3,0	0,03500	51,0	58
3E132M/6D	5,5	970	11,55	54,15	0,78	88,0	88,9	88,5	6,2	2,2	3,0	0,03940	56,0	58
3E160M/6D	7,5	972	15,55	73,68	0,78	89,1	89,4	88,4	6,3	2,6	3,0	0,07870	135	61
3E160L/6E	11	972	22,9	108,07	0,77	90,3	90,9	90,5	6,6	2,9	3,3	0,08580	144	62
3E180L/6E	15	975	30,8	146,92	0,77	91,2	91,6	91,0	6,7	2,9	3,1	0,15300	187	63
3E200L/6C	18,5	977	36,4	180,8	0,80	91,7	91,8	91,8	6,1	2,6	2,6	0,36100	225	64
3E200L/6D	22	978	42,5	214,8	0,81	92,2	92,9	93,0	6,2	2,6	2,7	0,39400	245	64
3E225S/6C	30	985	57,6	290,8	0,81	92,9	92,9	92,6	6,6	2,6	2,7	0,64000	330	65
3E250M/6C	37	988	68,8	357,6	0,83	93,4	93,6	93,5	6,8	2,7	2,8	1,06000	450	65
3G280S/6	45	990	92	434	0,75	93,7	93,7	92,9	6,9	3,0	2,8	1,5000	553	65
3G280M/6	55	990	107	531	0,79	94,1	94,1	92,8	7,3	3,3	3,2	1,7000	578	65
3G315S/6	75	992	140	722	0,82	94,6	94,6	94,4	7,2	2,7	3,0	2,9000	805	72
3G315M/6a	90	992	166	866	0,83	94,9	94,9	94,5	7,2	2,7	3,0	3,5000	860	72
3G315M/6b	110	992	198	1058	0,84	95,1	95,1	94,9	7,2	2,7	3,0	4,2000	980	72
3G315L/6	132	992	235	1270	0,85	95,4	95,4	95,2	7,2	2,7	3,0	4,3000	1150	72
3G355M/6a	160	993	290	1538	0,83	95,6	95,6	95,0	7,0	2,4	3,2	6,8000	1185	72

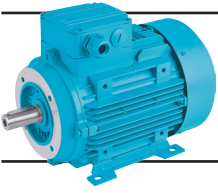

Elektrik Motorlarının Performans Değerleri

Electric Motors Ratings and Performance

Elektromotoren Leistungsdaten



400V 50Hz 3000 d/d / 400V 50Hz 3000 rpm / 400V 50Hz 3000 UpM

IE2

Tip Type Typ	Tam Yük Değerleri Full-load Data Vollastdaten							Kalkış Değerleri Starting Data Startdaten			Devrilme Momenti Breakdown Torque Kippmo- ment M_K/M_N	Atalet Momenti Moment of Inertia Trägheits- moment kgm^2	B3 Motor Ağırlığı B3 Motor Gewicht kg	Ses Seviyesi Noise Level Geräusch- pegel dB(A)
	Güç	Devir	Akım	Moment	Güç Faktörü	Verim % η			Akım	Moment				
	Power	Speed	Current	Torque	Power Factor	Efficiency % η			Current	Torque				
	Leistung	Drehzahl	Nennstrom	Drehmoment	Leistungsfaktor	Wirkungsgrad % η			Nennstrom	Drehmoment				
	kW	d/d rpm UpM	A	Nm	cos ϕ	4 / 4	3 / 4	1 / 2	I_A/I_N	M_A/M_N				
G56/2b*	0,12	2800	0,35	0,41	0,74	64,5	64,1	56,9	4,2	2,5	2,8	0,00012	2,8	42
G63/2a*	0,18	2820	0,5	0,61	0,73	64,4	64,2	57,7	4,6	2,9	2,9	0,00011	3,6	52
G63/2b*	0,25	2840	0,67	0,84	0,63	67,3	67,1	60,9	4,5	2,5	2,9	0,00013	4,0	52
2E71M/2A	0,37	2790	0,9	1,26	0,80	74,2	74,5	72,5	5,0	2,5	2,8	0,00031	5,5	54
2E71M/2B	0,55	2790	1,27	1,88	0,82	75,8	77,0	76,0	5,0	2,8	2,9	0,00037	6,3	54
2E80M/2A	0,75	2850	1,67	2,51	0,83	78,0	79,0	77,5	5,7	2,5	3,0	0,00089	8,7	56
2E80M/2B	1,1	2850	2,36	3,69	0,84	80,1	81,3	80,7	5,8	2,7	3,1	0,00103	9,7	56
2E90S/2A	1,5	2880	3,17	4,98	0,83	82,5	82,6	82,0	6,0	2,4	3,3	0,00152	14,1	60
2E90L/2B	2,2	2860	4,48	7,35	0,85	83,2	85,0	85,0	6,0	2,6	3,1	0,00178	15,5	60
2E100L/2B	3	2900	5,8	9,88	0,88	84,8	85,2	84,7	7,0	2,6	3,4	0,00380	20,8	63
2E112M/2A	4	2910	7,5	13,13	0,89	86,5	87,1	86,8	7,0	2,4	3,6	0,00530	25,7	66
2E132S/2A	5,5	2935	10,2	17,90	0,88	88,2	88,4	87,6	7,9	2,8	3,9	0,01550	41	68
2E132S/2B	7,5	2925	13,6	24,5	0,90	88,5	88,8	88,6	7,6	2,6	3,9	0,01730	45,2	68
2E160M/2A	11	2940	19,6	35,73	0,90	89,8	90,0	89,0	7,4	2,7	3,6	0,02920	107	70
2E160M/2B	15	2935	26,9	48,8	0,89	90,3	91,0	90,7	7,0	2,6	3,5	0,03320	113	70
2E160L/2C	18,5	2935	32,2	60,19	0,91	91,1	91,5	91,0	8,2	2,9	3,8	0,03910	130	70
2E180M/2A	22	2955	39,00	71,1	0,89	91,4	91,6	90,6	7,9	2,6	3,6	0,06300	163	71
2E200L/2A	30	2965	52	96,63	0,90	92,4	92,7	92,2	8,0	2,9	3,1	0,14600	230	74
2E200L/2B	37	2965	64	119,2	0,90	92,7	93,2	93,0	8,4	3,1	3,3	0,16200	240	75
2E225M/2B	45	2970	77,4	144,7	0,90	93,2	93,5	93,0	8,6	2,7	3,7	0,22000	310	75
2E250M/2B	55	2970	94,5	176,8	0,90	93,3	93,6	93,1	7,9	2,7	3,6	0,32800	440	77
2G280S/2	75	2980	127	240	0,91	93,9	94,1	92,5	8,0	2,9	3,2	0,62000	585	76
2G280M/2	90	2980	151	288	0,91	94,2	94,2	92,7	8,5	2,7	3,0	0,74000	645	76
2G315S/2	110	2980	186	353	0,91	94,3	94,3	92,8	8,0	2,5	3,0	1,20000	742	79
2G315M/2a	132	2980	223	423	0,90	94,6	94,5	92,9	8,0	2,5	3,0	1,40000	812	79
2G315M/2b	160	2980	266	513	0,92	94,8	94,8	93,4	8,0	2,5	3,0	1,50000	912	79

* : IE1 Verisi / IE1 Data / IE1 Daten

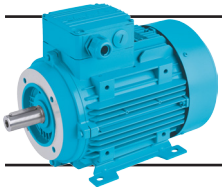

Elektrik Motorlarının Performans Değerleri

Electric Motors Ratings and Performance

Elektromotoren Leistungsdaten



400V 50Hz 1500 d/d / 400V 50Hz 1500 rpm / 400V 50Hz 1500 UpM

IE2

Tip Type Typ	Tam Yük Değerleri Full-load Data Vollastdaten							Kalkış Değerleri Starting Data Startdaten			Devrilme Momenti Breakdown Torque Kippmoment	Atalet Momenti Moment of Inertia Trägheitsmoment	B3 Motor Ağırlığı B3 Motor Weight B3 Motor Gewicht	Ses Seviyesi Noise Level Geräuschpegel
	Güç Power Leistung	Devir Speed Drehzahl	Akım Current Nennstrom	Moment Torque Drehmoment	Güç Faktörü Power Factor Leistungsfaktor	Verim % η Efficiency % η Wirkungsgrad % η			Akım Current Nennstrom	Moment Torque Drehmoment				
	kW	d/d rpm UpM	A	Nm	cos ϕ	4 / 4	3 / 4	1 / 2	I_A/I_N	M_A/M_N				
											M_K/M_N	kgm ²	kg	dB(A)
G63/4a*	0,12	1365	0,41	0,84	0,74	57,1	57,1	53,3	3,1	2,0	2,2	0,00017	3,4	43
G63/4b*	0,18	1340	0,6	1,28	0,73	59,7	59,7	55,8	2,9	2,0	2,0	0,00021	3,9	43
2E71M/4B	0,25	1425	0,71	1,68	0,69	74,0	73,5	70,5	4,4	2,0	3,0	0,00067	5,9	46
2E71M/4C	0,37	1425	1,0	2,47	0,70	76,1	75,5	71,5	4,6	2,0	3,0	0,00082	6,7	46
2E80M/4B	0,55	1440	1,45	3,65	0,71	77,1	76,7	75,0	5,2	2,0	3,0	0,00175	9,7	50
2E80M/4C	0,75	1440	1,95	4,97	0,70	79,6	79,2	77,0	5,2	2,0	3,0	0,00200	10,5	50
2E90S/4B	1,1	1440	2,6	7,3	0,75	81,4	81,4	80,5	5,6	2,2	3,1	0,00281	14,4	52
2E90L/4C	1,5	1440	3,4	9,95	0,77	82,8	83,0	82,0	6,0	2,3	3,2	0,00356	17,2	52
2E100L/4B	2,2	1445	4,85	14,6	0,78	84,3	85,3	84,2	6,0	2,4	3,2	0,00634	22,7	54
2E100L/4C	3	1440	6,42	19,89	0,79	85,5	85,7	84,6	6,3	2,4	3,3	0,00775	24,2	54
2E112M/4C	4	1450	8,2	26,35	0,81	86,8	87,4	86,5	6,6	2,5	3,4	0,00122	32	58
2E132S/4B	5,5	1455	11,2	36,1	0,81	87,7	88,6	88,0	6,7	2,6	3,2	0,02520	47,8	62
2E132M/4C	7,5	1460	15,1	49	0,81	88,7	89,0	89,0	7,0	2,7	3,3	0,03060	54,8	62
2E160M/4B	11	1465	21,3	71,7	0,83	89,8	90,3	89,5	6,9	2,4	3,0	0,05800	114	65
2E160L/4C	15	1460	28,8	98,12	0,83	90,6	91,3	90,9	6,9	2,6	3,0	0,07000	132	65
2E180M/4B	18,5	1465	34,9	120,6	0,84	91,2	91,5	91,4	6,9	2,5	3,0	0,11100	158	65
2E180L/4C	22	1465	41,4	143,4	0,84	91,6	91,7	91,5	7,1	2,6	3,2	0,12900	174	65
2E200L/4C	30	1475	55,5	194,24	0,85	92,3	93,0	93,2	7,6	3,0	3,1	0,23300	241	65
2E225S/4C	37	1475	66	239,5	0,87	93,0	93,8	93,8	7,8	3,0	3,1	0,33900	297	66
2E225M/4C	45	1475	80	291,4	0,87	93,1	94,0	94,3	7,8	3,0	3,0	0,38200	333	66
2E250M/4C	55	1478	95,5	355,4	0,89	93,5	94,3	94,4	7,9	3,2	3,0	0,62400	430	68
2G280S/4	75	1485	133	482	0,87	94,0	94,1	93,4	7,9	2,6	2,8	1,11000	605	67
2G280M/4	90	1485	158	579	0,87	94,3	94,5	93,8	7,4	2,9	3,0	1,32000	665	67
2G315S/4	110	1485	195	707	0,86	94,5	94,5	93,8	7,0	2,3	2,6	2,10000	784	74
2G315M/4a	132	1485	235	849	0,86	94,7	94,5	93,8	7,0	2,3	2,6	2,50000	861	74
2G315M/4b	160	1485	280	1029	0,87	95,0	94,9	94,0	7,0	2,3	2,6	2,70000	882	74

* : IE1 Verisi / IE1 Data / IE1 Daten

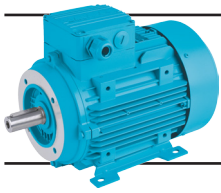

Elektrik Motorlarının Performans Değerleri

Electric Motors Ratings and Performance

Elektromotoren Leistungsdaten



400V 50Hz 1000 d/d / 400V 50Hz 1000 rpm / 400V 50Hz 1000 UpM

IE2

Tip Type Typ	Tam Yük Değerleri Full-load Data Vollastdaten							Kalkış Değerleri Starting Data Startdaten			Devrilme Momenti Breakdown Torque Kippmo- ment M_K/M_N	Atalet Momenti Moment of Inertia Trägheits- moment kgm^2	B3 Motor Ağırlığı B3 Motor Gewicht kg	Ses Seviyesi Noise Level Geräusch- pegel dB(A)
	Güç	Devir	Akım	Moment	Güç Faktörü	Verim % η			Akım	Moment				
	Power	Speed	Current	Torque	Power Factor	Efficiency % η			Current	Torque				
	Leistung	Drehzahl	Nennstrom	Drehmoment	Leistungsfaktor	Wirkungsgrad % η			Nennstrom	Drehmoment				
	kW	d/d rpm UpM	A	Nm	cos ϕ	4 / 4	3 / 4	1 / 2	I_A/I_N	M_A/M_N				
2E71M/6B	0,18	920	0,6	1,87	0,67	64,5	63,0	57,0	3,2	1,9	2,3	0,00076	5,9	42
2E71M/6C	0,25	920	0,78	2,59	0,69	66,5	66,0	61,0	3,3	1,9	2,3	0,00096	6,6	42
2E80M/6A	0,37	925	1,08	3,82	0,69	71,4	71,5	70,0	4,0	2,0	2,6	0,00176	9,1	45
2E80M/6B	0,55	932	1,5	5,64	0,72	73,5	74,0	71,0	4,2	2,1	2,6	0,00202	9,9	45
2E90S/6A	0,75	940	2,0	7,62	0,71	75,9	76,1	73,1	4,1	2,0	2,6	0,00229	13,3	48
2E90L/6B	1,1	940	2,9	11,18	0,70	78,1	78,3	75,0	4,3	2,1	2,6	0,00354	14,8	48
2E100L/6A	1,5	950	3,72	15	0,73	79,8	80,2	79,5	4,5	2,1	2,6	0,00680	20,2	52
2E112M/6A	2,2	960	5,32	21,9	0,73	81,8	82,0	81,5	5,3	2,1	2,7	0,01170	25	56
2E132S/6A	3	970	6,85	29,6	0,76	83,3	84,0	83,0	5,6	2,0	2,8	0,02610	42	60
2E132M/6B	4	970	8,8	39,38	0,77	85,2	85,7	85,3	5,2	2,1	2,6	0,03050	46	60
2E132M/6C	5,5	965	12	54,4	0,77	86,0	87,2	87,0	5,7	2,1	2,7	0,03500	51	60
2E160M/6B	7,5	972	16,3	73,68	0,76	87,2	88,1	87,7	5,6	2,4	2,7	0,05700	113	63
2E160L/6D	11	970	22,95	108,3	0,78	88,7	90,0	89,9	6,0	2,5	2,9	0,07870	136	63
2E180L/6D	15	975	31	146,9	0,78	89,7	90,5	90,2	6,2	2,5	2,9	0,13500	175	64
2E200L/6B	18,5	977	36,5	180,8	0,81	90,4	90,5	90,7	6,3	2,5	2,6	0,30100	205	64
2E200L/6C	22	978	43	214,8	0,81	91,1	91,3	91,2	6,2	2,5	2,6	0,33400	215	64
2E225S/6B	30	980	57,6	292,2	0,82	91,7	91,8	90,8	6,6	2,6	2,7	0,62800	305	65
2E250M/6B	37	982	69,6	359,8	0,83	92,3	92,6	92,5	6,8	2,7	2,8	0,95000	390	66
2G280S/6	45	990	92	434	0,76	92,7	92,7	90,9	7,0	3,3	2,6	1,50000	553	65
2G280M/6	55	990	107	531	0,80	93,1	93,1	91,5	7,0	3,3	2,6	1,60000	578	65
2G315S/6	75	990	140	723	0,82	93,7	93,7	92,4	7,0	2,5	3,0	2,50000	727	72
2G315M/6a	90	990	166	868	0,83	94,0	94,0	92,6	7,0	2,5	3,0	3,10000	805	72
2G315M/6b	110	990	198	1061	0,85	94,3	94,3	92,7	7,0	2,5	3,0	3,20000	860	72
2G315L/6a	132	990	235	1273	0,86	94,6	94,6	93,0	7,0	2,5	3,0	3,50000	1020	72
2G315L/6b	160	990	290	1543	0,84	94,8	94,8	93,2	7,0	2,5	3,0	3,80000	1120	72

