

Kare Gvde Sonsuz Vidalı
Redktrler rn Katalođu
Square Worm Gearboxes



09
2017

DİĞER ÜRÜNLERİMİZ
OUR OTHER PRODUCTS



HE-MHE-KH-MKH
Serisi Ürün Kataloğu | Series Product Catalogue

06
2014

HE-MHE-KH-MKH
Serisi Ürün Kataloğu | Series Product Catalogue



Ekstruder Extruder
Serisi Ürün Kataloğu | Series Product Catalogue

10
2014

Ekstruder Extruder
Serisi Ürün Kataloğu | Series Product Catalogue

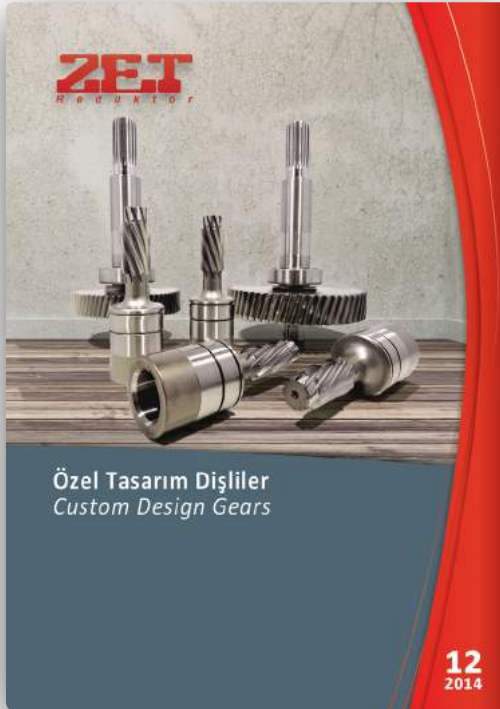

Özel Tasarım Dişliler
Custom Design Gears

12
2014

Özel Tasarım Dişliler
Custom Design Gears



Özel Tasarım Redüktörler
Custom Design Gearboxes

11
2014

Özel Tasarım Redüktörler
Custom Design Gearboxes

Kare Gövde Sonsuz Vidalı Redüktörler / Worm Gearboxes

2

Tek Parça Alüminyum Alaşımli Gövde

MIL-STD 276 standardına göre üretilmiş gövde için herhangi bir ikincil yüzey işlemine gerek yoktur. Yüzeyler boyanabilir. Hafif gövde yapısı ve yüksek mukavemet birlikte sunulmaktadır. Yüksek hasssiyette işlenmiştir.

Single-piece aluminum alloy housing

Is vacuum impregnated (MIL-STD 276) for protection and sealing.

No secondary finish required but readily accepts paint. Combines light weight with high tensile strength. Precision machined for alignment of bearings and gearing.

Tek parça alaşımli çelik giriş mili ve sonsuz vida çark dişlisi

Yüksek helis açılı sonsuz vida, ısıl işlem görmüş (58-60 HRC), silindirik ve profil taşlanmıştır. Düşük ses seviyesi ve yüksek verim için çeşitli profil düzeltmeleri yapılmıştır.

Single piece alloy steel input shaft and worm shaft.

High helix angle worm is case-hardened (Rc 58-60), ground, teeth are profiled and radiused, for noise reduction and enhanced efficiency.

Giriş Mili

Sonsuz vida milinde çok yüklere, dur kalk çalışmaya ve ters yönlü çalışmaya uygun ön gerilmeli rulmanlar, yüksek sıcaklığa dayanıklı NBR keçeler ile birlikte kullanılmıştır.

Oversized bearings

Support positively-retained, high speed shaft for higher shock load capacity - ideal for frequent starting and reversing application. Premium, Nitrile® high temperature seals each end.

Keçe

Yüksek sıcaklığa dayanıklı NBR keçeler kullanılmaktadır.

Premium, high temperature

Nitrile® output seals

Çıkış Mili

Tork kollu kullanıma uygun kovan çıkış mili, tek ve çift çıkış mili opsiyonları sunulmaktadır.

Standard hollow output shaft mounting

Reduces total drive envelope size, weight and cost.

Single and double solid output shaft is available.

Yağlama

Redüktörler montaj sonrası -15, +130 derece sıcaklığa dayanıklı sentetik yağlar ile yağlanmaktadır. Havalandırma Tapası kullanımına gerek yoktur.

Vent Free Design.

No breather or vents to leak! Factory lubricated for life with synthetic, semi-fluid gear lubricant with an operating range of -15°C to 130°C.

Flanş

Tüm giriş flanşları IEC standardına uygundur.

Flange

Fully modular to IEC and compact integrated motor. NEMA C flange.

Sonsuz Vida Çark Dişlisi

Santrüfjü döküm tekniği ile üretilmiş bronz alaşımli sonsuz vida çarkı maksimum mukavemet için çelik göbek ile birleştirilmiştir.

Bronze alloy worm gears.

Is centrifugally cast onto an iron hub for maximum strength and superior life.

Rulmanlar

Yüksek radyal ve eksenel yük taşıma kapasitesine sahip rulmanlar kullanılmıştır.

Oversize bearing

For radial load capability and maximum hollow output shaft diameter.

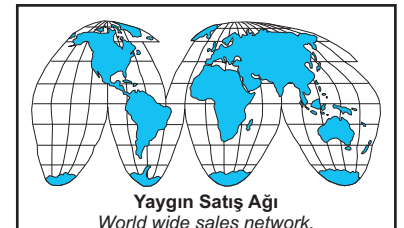
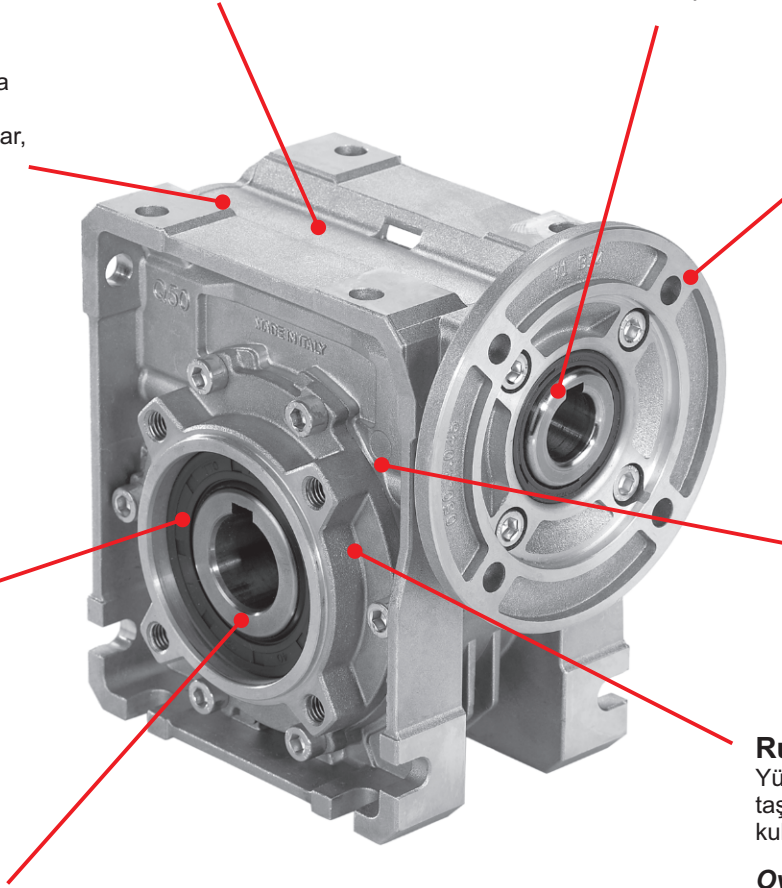

Kare Gövde Sonsuz Vidalı Redüktörler / Worm Gearboxes

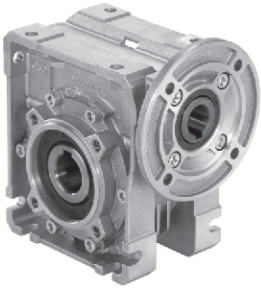

Tip / Types →

Sayfa / On page								
2-5	2-7	2-9	2-11	2-13	2-15	2-17	2-19	2-21
Q30 21Nm	Q45 41Nm	Q50 72Nm	Q63 147Nm	Q75 270Nm	Q85 347Nm	Q11 651Nm	Q13 1050Nm	Q15 1550Nm

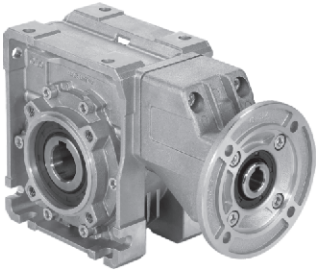

Tip / Types →

Sayfa / On page					
2-23	2-25	2-27	2-29	2-31	2-33
P4Q 55Nm	P5Q 88Nm	P6Q 187Nm	P7Q 310Nm	P8Q 440Nm	P1Q 803Nm

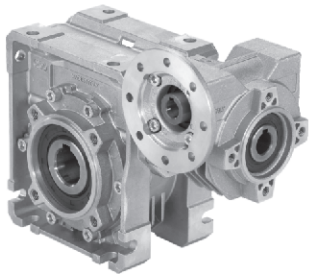

Tip / Types →

Sayfa / On page						
2-35	2-37	2-39	2-41	2-43	2-45	2-47
43Q 69Nm	53Q 109Nm	63Q 230Nm	64Q 265Nm	74Q 359Nm	84Q 518Nm	15Q 978Nm

NASIL SİPARİŞ EDİLİR / HOW TO ORDER

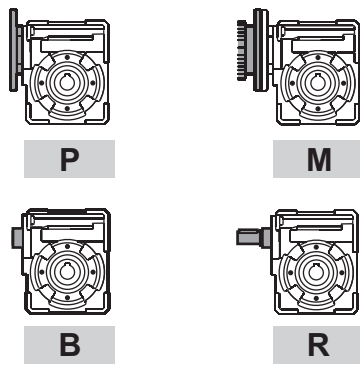
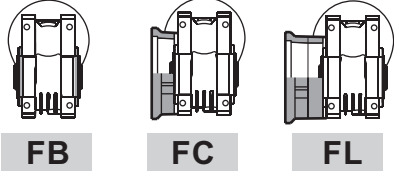
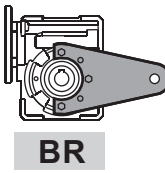
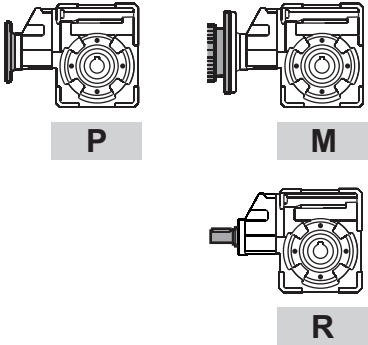
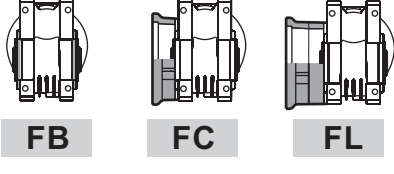
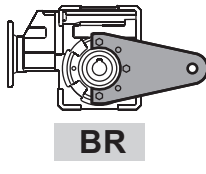
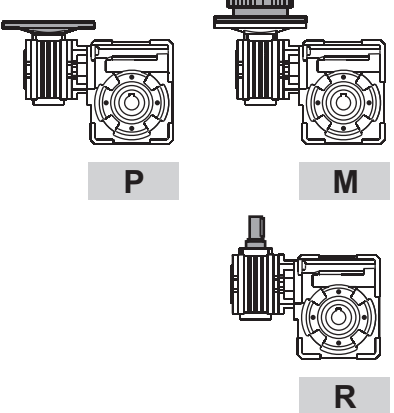
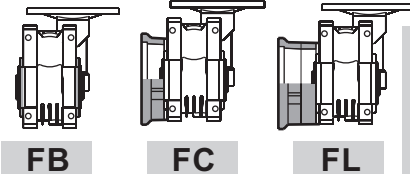
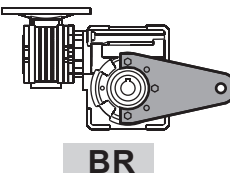

2

Tip / Type	Gövde Büyüklüğü / Size	Montaj Şekli / Mounting
P	Q45	FC
<p>Sonsuz Vidalı Redüktörler Worm gearboxes</p>  <p style="text-align: center;">P M B R</p>	<p>Q30 Q45 Q50 Q63 Q75 Q85 Q11 Q13 Q15</p>	 <p style="text-align: center;">FB FC FL</p> <p style="text-align: center;">F1 F2 F3 F4</p>  <p style="text-align: center;">BR</p>
<p>Yavru dişli sonsuz vidalı redüktörler Worm gearboxes with primary reduction</p>  <p style="text-align: center;">P M R</p>	<p>P4Q P5Q P6Q P7Q P8Q P1Q</p>	 <p style="text-align: center;">FB FC FL</p> <p style="text-align: center;">F1 F2 F3 F4</p>  <p style="text-align: center;">BR</p>
<p>Çift sonsuz vidalı redüktörler Combined worm gearboxes</p>  <p style="text-align: center;">P M R</p>	<p>43Q 53Q 63Q 64Q 74Q 84Q 15Q</p>	 <p style="text-align: center;">FB FC FL</p> <p style="text-align: center;">F1 F2 F3 F4</p>  <p style="text-align: center;">BR</p>

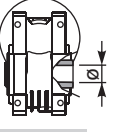
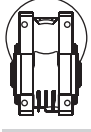
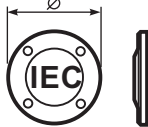

Ürünlerimiz isteğe bağlı olarak ATEX standartlarında tedarik edilebilir.
On request we can deliver our products according to the ATEX

NASIL SİPARİŞ EDİLİR / HOW TO ORDER

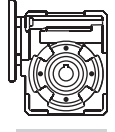
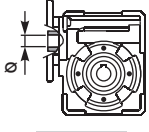
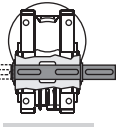
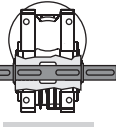
Tahvil Oranı Ratio	Çıkış Mili Hub	Çıkış Mili Konfigürasyonu Output shaft	Motor Büyüklüğü Motor size	Terminal Kutusu Pozisyonu Terminal box position	Montaj Pozisyonu Mounting position	Düşük Çaplı Giriş Mili Konfigürasyonu Reduced Input bore	Montaj Pozisyonu Mountin position
10	C	Ø	-Q	B	B3	-	---
Ölçü tablolarına bakınız See technical data table							Yalnızca çift sonsuz vidalı redüktörler için. Ölçü sayfalarına bakınız. Only for combined units See technical data table
	C STANDART Q30 ⇒ ø14 Q45 ⇒ ø18 Q50 ⇒ ø25 Q63 ⇒ ø25 Q75 ⇒ ø30 Q85 ⇒ ø35 Q11 ⇒ ø42 Q13 ⇒ ø45 Q15 ⇒ ø50	Ø	-M Flanşsız without flange B5 -A =56 (ø120) -B =63 (ø140) -C =71 (ø160) -D =80 (ø200) -E =90 (ø200) -F =100+112 (ø250) -G =132 (ø300) -H =160 (ø350)	A	B3	- Tanımlama yapılmamış ise Nothing indication standard bore	
	I Paslanmaz çelik çıkış mili Stainless steel hub		B5 -A =56 (ø120) -B =63 (ø140) -C =71 (ø160) -D =80 (ø200) -E =90 (ø200) -F =100+112 (ø250) -G =132 (ø300) -H =160 (ø350)	B STANDART	B8	P Delik mil çapı bir kademe düşürüldü ise Input bore reduced one size	
	S Paslanmaz çelik çıkış mili Stainless steel hub		B14 -O =56 (ø80) -P =63 (ø90) -Q =71 (ø105) -R =80 (ø120) -T =90 (ø140) -U =100+112 (ø160) -V =132 (ø200)	C	B6	Q a Bc C' c d B' H C C B' B' C B b' e' e' d' e' C B ø e' c' b' C B ø b' C B B' c' C C B' B' C	
	X Paslanmaz çelik çıkış mili Stainless steel hub		-O =Tip R -S =Tip R S serisi	D	B7	Örnek / Ex. Giriş Flanşı / Input Flange 71 B14 Standart / Standard ø14 Düşük / Reduced ø11	
				V5	V5	Örnek / Ex. Giriş Flanşı / Input Flange 71 B14 Standart / Standard ø14 Düşük / Reduced ø9	
				V6	V6		

GEREKLİ FORMÜLLER / USEFUL FORMULAS

GEREKLİ GÜÇ / REQUIRED POWER

Kaldırma / Lifting

$$P [KW] = \frac{M [Kg] \cdot g [9.81] \cdot v [m / s]}{1000}$$

Döndürme / Rotation

$$P [KW] = \frac{M [Nm] \cdot n [d/d]}{9550}$$

Doğrusal hareket / Linear movement

$$P [KW] = \frac{F [N] \cdot v [m / s]}{1000}$$

MOMENT / TORQUE

$$M [Nm] = \frac{9550 \cdot P [KW]}{n [d/d]}$$

RADYAL YÜKLER / RADIAL LOADS

- Radyal yükler giriş ve çıkış milinde harici güç aktarım elemanları tarafından oluşturulur.
- Radial load generated by external transmissions keyed onto input and/or output shafts.

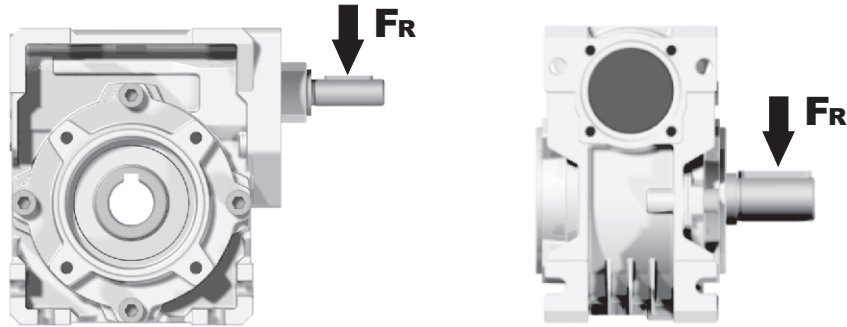

$$F_R [N] = \frac{M [Nm] \cdot 2000}{d [mm]} \cdot f_k$$

M	Çıkış momenti / Output torque
d	Güç aktarım elemanı çapı / Diameter of driving element
f_k	Düzeltilme katsayısı / Factor 1.15 Dişli / Gearwheels 1.25 Zincir Dişli / Chain sprochets 1.75 V kayış / Narrow v-belt pulley 2.50 Düz kayış / Flat-belt pulley

- Daha yüksek radyal yükler için teknik ofisimiz ile iletişime geçiniz.
- If your application requires higher radial loads, contact our technical office. Higher load may be possible.

REDÜKTÖR SEÇİMİ NASIL YAPILIR / HOW TO SELECT A GEARBOX

2

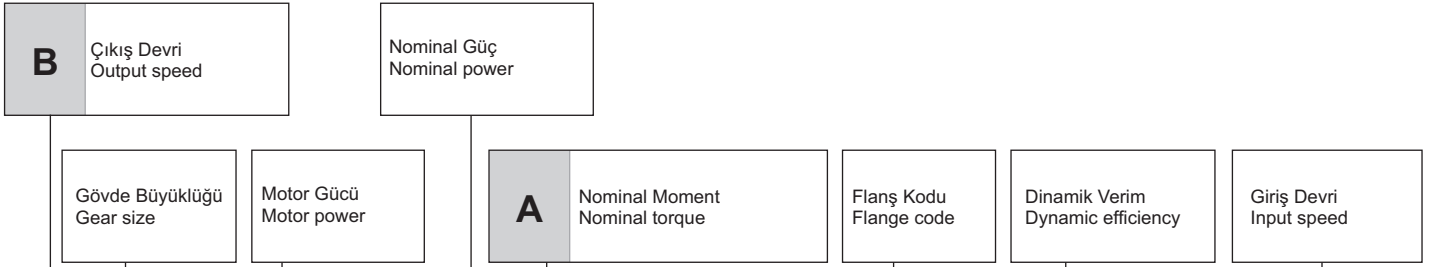

Q45

Kare Gövde
Sonsuz Vidalı Redüktörler
Square - Gear
41Nm

ZET
Redüktör

PERFORMANS TABLOLARI-ALÜMİNYUM
RATING-ALUMINUM WORM GEARBOXES



HIZLI SEÇİM / Quick Selection

Giriş devri (n_1) = 1400 d/d

Çıkış devri n_2 [d/d]	Tahvil i	Motor gücü P_{1M} [kW]	Çıkış momenti M_{2M} [Nm]	Servis faktörü f.s.	Nominal güç P_{1R} [kW]	Nominal moment M_{2R} [Nm]	Uygun B5 motor flanşları		Uygun B14 motor flanşları			Dinamik verim RD	Modül [mm]	Tahvil kodu
							-B	-C	-O	-P	-Q			
200	7	0.37	14	2.2	0.80	30	B		B-C	B-C		80	2.2	01
140	10	0.37	20	1.5	0.57	30	B		B-C	B-C		79	2.2	02
100	14	0.37	27	1.1	0.41	30	B		B-C	B-C		77	2.4	03



fs		Günlük Çalışma Süresi Oper. hours per day		
Yük Sınıfı ve Saatteki Dur-Kalk Sayısı Type of load and starts per hour		<2 sa	2-8 sa	8-16sa
Sürekli yada Aralıklı Çalışmada Dur-Kalk Sayısı / Saat ≤ 10 Application with start / stop	Düzgün Yükleme / Uniform	0.9	1	1.25
	Orta Darbeli Yükleme / Moderate	1	1.25	1.5
	Ağır Yükleme / Heavy	1.25	1.5	1.75
Aralıklı Çalışmada Dur-Kalk Sayısı / Saat > 10 Intermittent application with start / hour	Düzgün Yükleme / Uniform	1.25	1.5	1.75
	Orta Darbeli Yükleme / Moderate	1.5	1.75	2
	Ağır Yükleme / Heavy	1.75	2	2.25

D	Standart motor flanşı Motor flange available	
B)	Burç ile montajı yapılabilir Mounting with reduction ring	
C)	Terminal kutusu flanş pozisyonu Motor flangeholes position/terminal box position	
B)	Burç kullanılmadan montajı yapılabilir Available without reduction bushes	

A	Servis faktörüne bağlı gerekli moment belirlenir	Select required torque (according to service factor)
B	Gerekli çıkış devri belirlenir	Select output speed
C	Aynı satırda belirlenen redüktörün tahvil oranı görülebilir	On the same line of selected geared motor, you can find the gear ratio
D	Uygun motor flanşı belirlenir (Gerekli olduğu durumlarda)	Select motor flange available (if requested)



HIZLI SEÇİM / Quick Selection

Giriş Devri (n_1) = 1400 d/d

Çıkış devri n_2 [d/d]	Tahvil i	Motor gücü P_{1M} [kW]	Çıkış Momenti M_{2M} [Nm]	Servis Faktörü f.s.	Nominal güç P_{1R} [kW]	Nominal moment M_{2R} [Nm]	Uygun B5 motor Flanşları		Uygun B14 motor flanşları		Dinamik verim RD	Modül [mm]	Tahvil kodu
							-A	-B	-O	-P			
							56	63	56	63			
280	5	0.18	5	3.3	0.60	17	B		B-C		82	1.26	01
200	7	0.18	7	2.4	0.44	17	B		B-C		80	1.44	02
140	10	0.18	10	1.8	0.32	17	B		B-C		78	1.44	03
93	15	0.18	13	1.4	0.25	19	B		B-C		73	1.44	04
70	20	0.18	17	1.1	0.20	19	B		B-C		70	1.09	05
47	30	0.12	15	1.4	0.17	21	B		B-C		62	1.44	06
35	40	0.12	19	1.1	0.13	20	B		B-C		57	1.09	07
23	61	0.09	19	1.1	0.10	20	B		B-C		50	0.72	08
17.5	80	0.09	16	1.0	0.06	16	B		B-C		48	0.56	09

Uygun Motor Flanşları
Motor Flanges Available

B) Burç ile montaj yapılabilir
Supplied with Reduction Bushing

B) Burç Kullanılmadan Montajı Yapılabilir
Available on Request without Reduction Bushing

C) Teminal Kutusu flanş pozisyonu
Motor Flange Holes Position

TR Q30 gövde sonsuz vidalı redüktörler ömürlük sentetik yağ ile yağlanmıştır. V5-V6 montaj pozisyonları için teknik ofisimiz ile iletişime geçiniz.

Tablo 1'de uygun yağ seçenekleri ve yağlama miktarları tanımlanmıştır.

Tablo 2'de izin verilebilir radyal ve aksel yükler tanımlanmıştır.

EN Unit Q30 is supplied with synthetic oil, providing "long life" lubrication. For mounting position V5-V6 please contact us. See table 1 for lubrication and recommended quantity. In table 2 please see possible radial loads and axial loads on the gearbox.

YAĞLAMA 030 Yağ Miktarı 0.03 Lt.
LUBRICATION 030 Oil Quantity 0.03 Lt.

AGIP Telium VSF 320

SHELL Omala S4 WE 320

Daha fazla ayrıntı için internet sitemizi inceleyiniz.

For all details on lubrication and plugs check our website

Tablo 1

RADYAL VE EKSENEL YÜKLER / RADIAL AND AXIAL LOADS

Çıkış Mili
Output Shaft

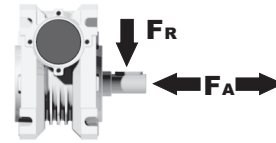

n_2 [d/d]	FA [N]	FR [N]
200	120	600
150	140	700
100	160	800
75	180	900
50	200	1000
25	250	1250
15	280	1400

Giriş Mili
Input Shaft

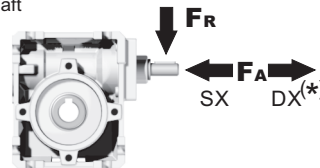

n_1 [d/d]	FA [N]	FR [N]
1400	20	100

*DX yönünde aksel yüke izin verilmez

Strong axial loads in the DX direction are not allowed.

Tablo 2

PQ30**FB**... Standart Redüktör
Basic wormbox

Ağırlık
Gearbox
weight **1.15 kg**

M. Flanşları	Kit Kodu	øF	A
56B5	K030.4.041	120	61.5
63B5	K030.4.042	140	62.5
56B14	K030.4.046	80	61.5
63B14	K030.4.045	90	62.5

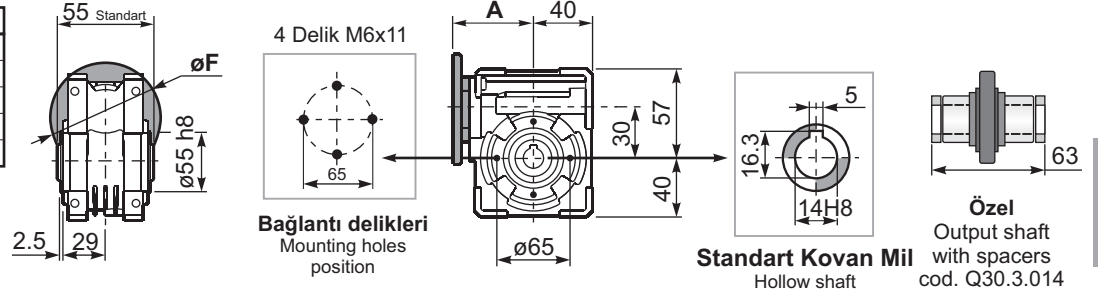

PQ30**FC**... Kare Çıkış Flanşı
Square flange

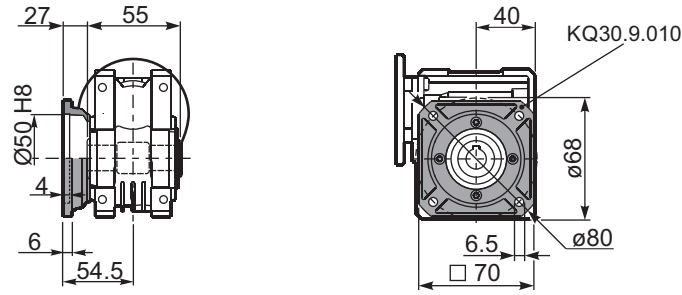

PQ30**FB**... Ayak
Feet

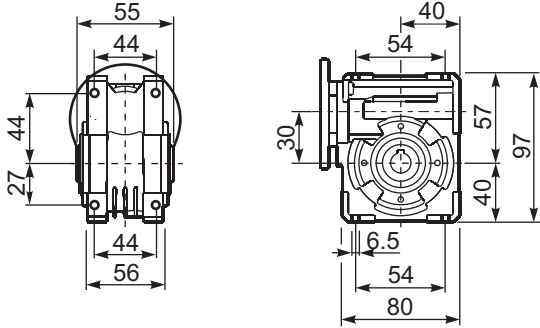

PQ30**BR**... Tork Kolu
Reaction arm

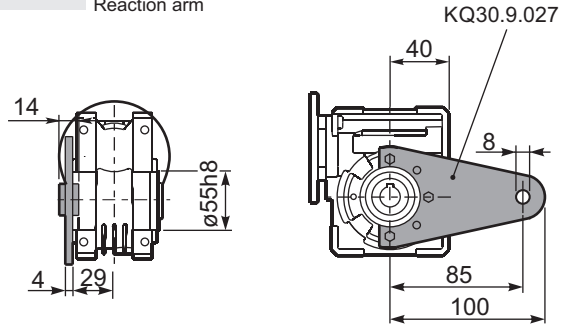

RQ30**FB**... Giriş Mili
Input shaft

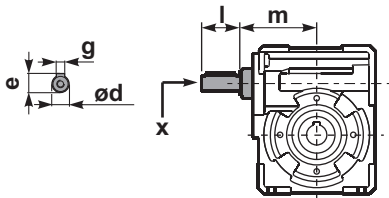

PQ30.....**S**... Tek Çıkış Mili
Single Shaft

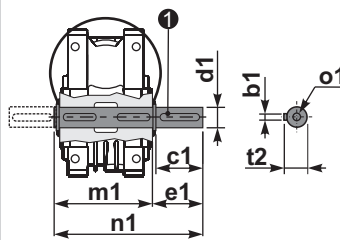

PQ30.....**D**... Çift Çıkış Mili
Double Shaft

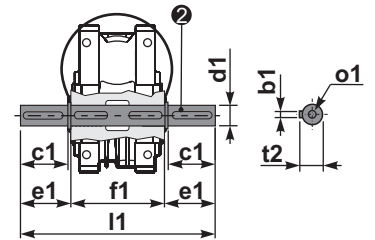

① Kit Kodu K030.5.028 Tip B

② Kit Kodu K030.5.029 Tip B

	ød	e	g	l	m	x	Kit Kodu
Tip B	9 h6	10.2	3	20	58	-	K030.5.006 PAM63
Tip S	-	-	-	-	-	-	-

	b1	c1	d1	e1	f1	l1	m1	n1	t2	o1
Tip B	5	25	14 ^{-0.005} _{-0.020}	35.5	55	126	59	94.5	16	M5x14
Tip S	-	-	-	-	-	-	-	-	-	-



HIZLI SEÇİM / Quick Selection

Giriş Devri (n₁) = 1400 d/d

Çıkış devri n ₂ [d/d]	Tahvil i	Motor gücü P _{1M} [kW]	Çıkış Momenti M _{2M} [Nm]	Servis Faktörü f.s.	Nominal güç P _{1R} [kW]	Nominal moment M _{2R} [Nm]	Uygun B5 motor Flanşları		Uygun B14 motor flanşları			Dinamik verim RD	Modül [mm]	Tahvil kodu
							-B	-C	-O	-P	-Q			
							63	71	56	63	71			
200	7	0.37	14	2.2	0.80	30	B		B-C	B-C		80	2.2	01
140	10	0.37	20	1.5	0.57	30	B		B-C	B-C		79	2.2	02
100	14	0.37	27	1.1	0.41	30	B		B-C	B-C		77	2.4	03
67	21	0.37	36	1.2	0.43	41	B		B-C	B-C		67	1.6	04
50	28	0.25	31	1.3	0.33	41	B		B-C	B-C		65	2.5	05
38	37	0.25	40	1.0	0.26	41	B		B-C	B-C		63	1.8	06
30	46	0.25	46	0.9	0.22	41	B		B-C	B-C		59	1.5	07
23	60	0.18	41	1.0	0.18	41	B		B-C	B-C		56	1.2	08
20	70	0.12	31	1.0	0.12	30	B		B-C	B-C		54	1.0	09
13.7	102	0.09	31	1.0	0.09	29	B		B-C	B-C		49	0.72	10

Uygun Motor Flanşları
Motor Flanges Available

B) Burç ile montaj yapılabilir
Supplied with Reduction Bushing

B) Burç Kullanılmadan Montajı Yapılabilir
Available on Request without Reduction Bushing

C) Teminal Kutusu flanş pozisyonu
Motor Flange Holes Position

* Tablolarda verilen değerlerin üzerindeki motor güçleri için seçimleri M_{2R} değerini referans olarak yapınız.
Power higher than the maximum one which can be supported by the gearbox. Select according to the torque M_{2R}

TR Q45 gövde sonsuz vidalı redüktörler ömürlük sentetik yağ ile yağlanmıştır. V5-V6 montaj pozisyonları için teknik ofisimiz ile iletişime geçiniz.

Tablo 1'de uygun yağ seçenekleri ve yağlama miktarları tanımlanmıştır.

Tablo 2'de izin verilebilir radyal ve aksel yükler tanımlanmıştır.

EN Unit Q45 is supplied with synthetic oil, providing "long life" lubrication. For mounting position V5-V6 please contact us.
See table 1 for lubrication and recommended quantity.
In table 2 please see possible radial loads and axial loads on the gearbox.

YAĞLAMA Q45 Yağ Miktarı 0.09 Lt.
LUBRICATION Q45 Oil Quantity 0.09 Lt.

AGIP Telium VSF 320

SHELL Omala S4 WE 320

Daha fazla ayrıntı için internet sitemizi inceleyiniz.

Tablo 1

For all details on lubrication and plugs check our website

RADYAL VE EKSENEL YÜKLER / RADIAL AND AXIAL LOADS

Çıkış Mili
Output Shaft

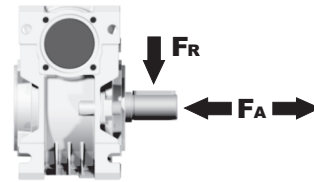

n ₂ [d/d]	FA [N]	FR [N]
200	180	900
150	200	1000
100	220	1100
75	240	1200
50	260	1400
25	300	1800
15	400	2000

Giriş Mili
Input Shaft

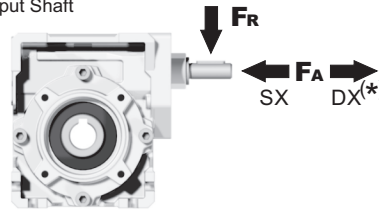

n ₁ [d/d]	FA [N]	FR [N]
1400	42	210

*DX yönünde aksel yüke izin verilmez.
Strong axial loads in the DX direction are not allowed.

Tablo 2

PQ45**FB**... Standart Redüktör
Basic wormbox

M. Flanşlan	Kit Kodu	øF	A
63B5	K050.4.041	138	80
71B5	K050.4.042	160	77.5
56B14	KC40.4.049	80	77.5
63B14	K050.4.047	90	80
71B14	K050.4.045	105	77.5

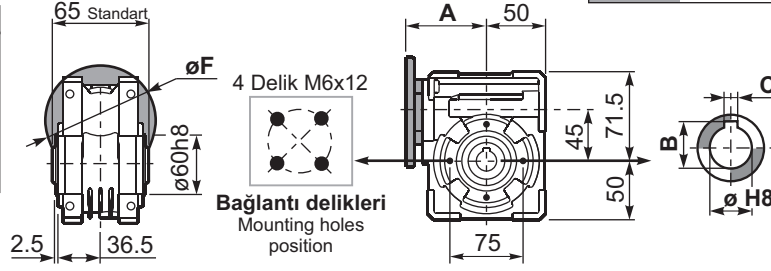

Ağırlık
Gearbox
weight
2.30 kg

ø H8	B	C	*Burç Kodu
18 Standart	20.8	6	Q45.3.018
19 Özel	21.8	6	Q45.3.019
20 Özel	22.8	6	Q45.3.020

*Özel
Burçlu Çıkış Mili

PQ45**FC**... Kare Çıkış Flanşı
Square flange

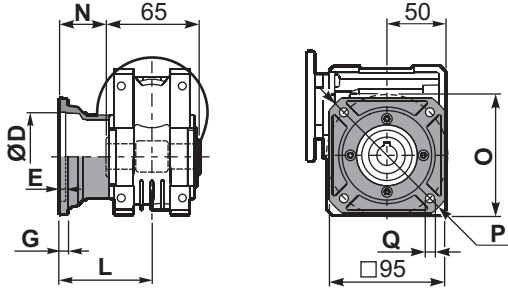

Tip B	øD	E	G	L	N	O	P	Q	Kit Kodu
FC	60 H8	4	7	67	34.5	75	110	9	KQ45.9.010
FL	60 H8	4	7	97	64.5	75	110	9	KQ45.9.011

PQ45**F1**... Yuvarlak Çıkış Flanşı
Round flange

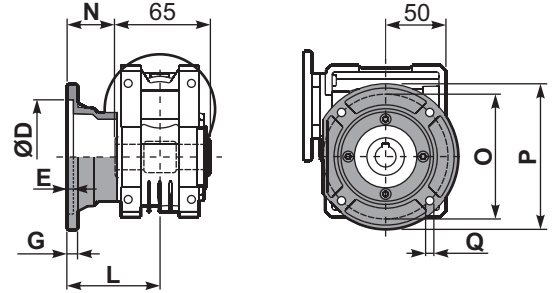

Tip S	øD	E	G	L	N	O	P	Q	Kit Kodu
F1	95H8	5	9	80	47.5	115	140	9.5	KSQ45.9.012
F2	80H8	5	12	58	25.5	100	120	9	KSQ45.9.013

PQ45**FB**... Ayak
Feet

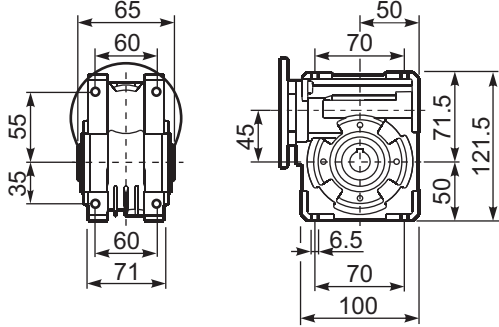

PQ45**BR**... Tork Kolu
Reaction arm

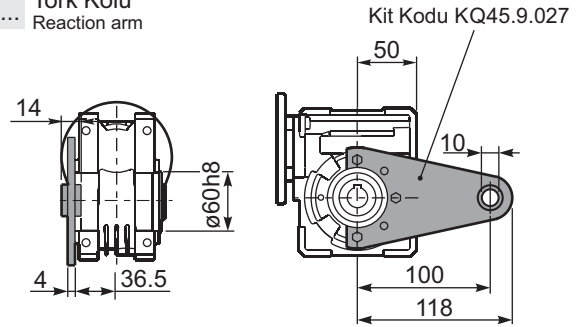

RQ45**FB**... Giriş Mili
Input shaft

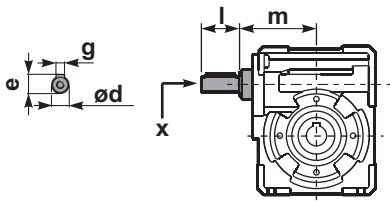

	ød	e	g	l	m	x	Kit Kodu
Tip B	11 h6	12.5	4	30	74	-	① K045.5.006 PAM71 ② -
Tip S	-	-	-	-	-	-	① - ② -

PQ45.....**S**... Tek Çıkış Mili
Single Shaft

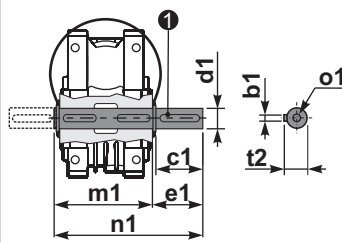

① Kit Kodu K045.5.028 Tip B
Kit Kodu KS045.5.030 Tip S

PQ45.....**D**... Çift Çıkış Mili
Double Shaft

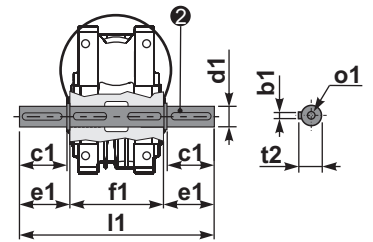

② Kit Kodu K045.5.029 Tip B
Kit Kodu KS045.5.031 Tip S

	b1	c1	d1	e1	f1	l1	m1	n1	t2	ø1
Tip B	6	32	18 ^{-0.005} _{-0.020}	43	65	151	70	113	20.5	M6x18
Tip S	6	40	19 ^{-0.005} _{-0.020}	58.5	65	182	70	128.5	21.5	M8x20



HIZLI SEÇİM / Quick Selection

Giriş Devri (n_1) = 1400 d/d

Çıkış devri n_2 [d/d]	Tahvil i	Motor gücü P_{1M} [kW]	Çıkış Momenti M_{2M} [Nm]	Servis Faktörü f.s.	Nominal güç P_{1R} [kW]	Nominal moment M_{2R} [Nm]	Uygun B5 motor Flanşları			Uygun B14 motor flanşları				Dinamik verim RD	Modül [mm]	Tahvil kodu
							-B	-C	-D	-O	-P	-Q	-R			
							63	71	80	56	63	71	80			
200	7	0.75	29	1.9	1.5	57	B	B			B-C	B		82	2.5	01
140	10	0.75	41	1.5	1.1	62	B	B			B-C	B		80	2.4	02
100	14	0.75	57	1.2	0.90	68	B	B			B-C	B		79	2.6	03
78	18	0.55	51	1.2	0.67	62	B	B			B-C	B		75	2.0	04
54	26	0.55	67	1.0	0.54	66	B	B			B-C	B		69	2.7	05
47	30	0.55	79	0.9	0.50	72	B	B			B-C	B		70	2.5	12
39	36	0.37	63	1.2	0.43	72	B			B-C	B-C			69	2.1	06
33	43	0.37	72	1.0	0.35	68	B			B-C	B-C			66	1.8	07
23	60	0.25	59	1.0	0.26	62	B			B-C	B-C			58	1.3	08
21	68	0.25	66	0.9	0.22	58	B			B-C	B-C			57	1.2	09
17.5	80	0.18	53	1.1	0.19	57	B			B-C	B-C			54	1.0	10
14	100	0.12	41	1.3	0.15	51	B			B-C	B-C			50	0.8	11

Uygun Motor Flanşları
Motor Flanges Available

B) Burç ile montaj yapılabilir
Supplied with Reduction Bushing

B) Burç Kullanılmadan Montajı Yapılabilir
Available on Request without Reduction Bushing

C) Teminal Kutusu flanş pozisyonu
Motor Flange Holes Position

TR Q50 gövde sonsuz vidalı redüktörler ömürlük sentetik yağ ile yağlanmıştır. V5-V6 montaj pozisyonları için teknik ofisimiz ile iletişime geçiniz. Tablo 1'de uygun yağ seçenekleri ve yağlama miktarları tanımlanmıştır. Tablo 2'de izin verilebilir radyal ve eksenel yükler tanımlanmıştır.

EN Unit Q50 is supplied with synthetic oil, providing "long life" lubrication. For mounting position V5-V6 please contact us. See table 1 for lubrication and recommended quantity. In table 2 please see possible radial loads and axial loads on the gearbox.

YAĞLAMA Q50 Oil Yağ Miktarı 0.14 Lt.
LUBRICATION Q50 Oil Quantity 0.14 Lt.

AGIP Telium VSF 320

SHELL Omala S4 WE 320

Daha fazla ayrıntı için internet sitemizi inceleyiniz.
For all details on lubrication and plugs check our website

Tablo 1

RADYAL VE EKSENEL YÜKLER / RADIAL AND AXIAL LOADS

Çıkış Mili
Output Shaft

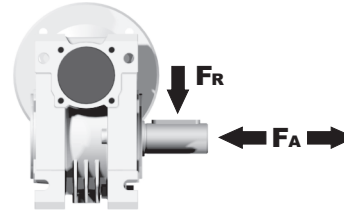

n_2 [d/d]	FA [N]	FR [N]
200	240	1200
150	280	1400
100	300	1500
75	340	1700
50	380	1900
25	480	2500
15	560	2800

Giriş Mili
Input Shaft

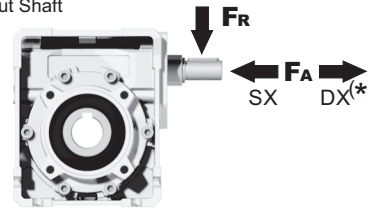

n_1 [d/d]	FA [N]	FR [N]
1400	76	380

*DX yönünde eksenel yüke izin verilmez
Strong axial loads in the DX direction are not allowed.

Tablo 2

PQ50**FB**... Standart Redüktör
Basic wormbox

M. Flanşlar	Kit Kodu	øF	A
63B5	K050.4.041	138	83.5
71B5	K050.4.042	160	81
80B5	K050.4.043	200	81.5
56B14	KC40.4.049	80	81
63B14	K050.4.047	90	83.5
71B14	K050.4.045	105	81
80B14	K050.4.046	120	81.5

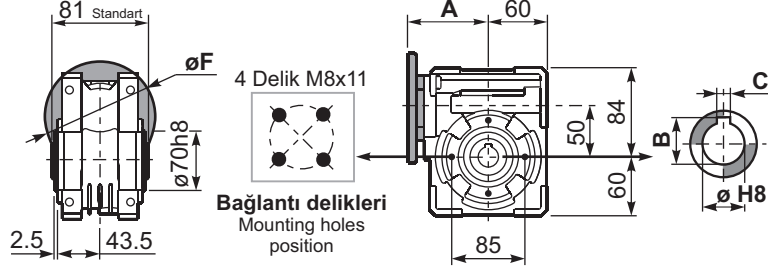

Ağırlık
Gearbox
weight

3.25 kg

ø H8	B	C	*Burç Kodu
25 Standart	28.3	8	Q50.3.025
24 Özel	27.3	8	Q50.3.024

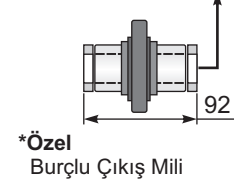

*Özel
Burçlu Çıkış Mili

PQ50**FC**... Kare Çıkış Flanşı
Square flange

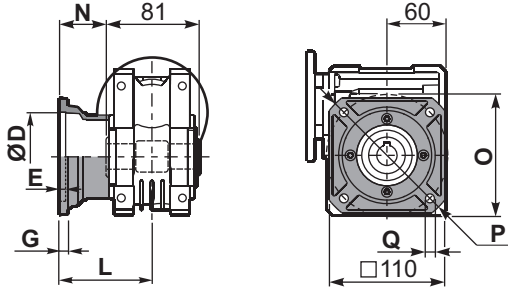

Tip B	øD	E	G	L	N	O	P	Q	Kit Kodu
FC	70 H8	5	9	90	49.5	85	125	11	KQ50.9.010
FL	70 H8	5	9	120	79.5	85	125	11	KQ50.9.011

PQ50**F1**... Yuvarlak Çıkış Flanşı
Round flange

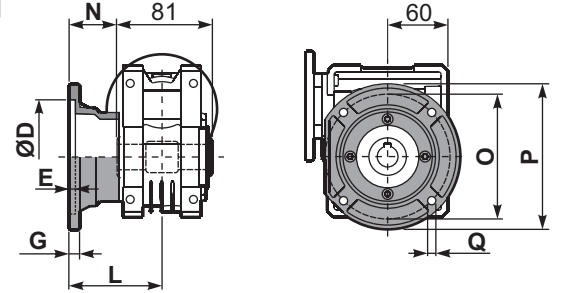

Tip S	øD	E	G	L	N	O	P	Q	Kit Kodu
F1	110 H8	5	10	89	48.5	130	160	9.5	KSQ50.9.012
F2	95 H8	5	14.5	72	31.5	115	140	11	KSQ50.9.013

PQ50**FB**... Ayak
Feet

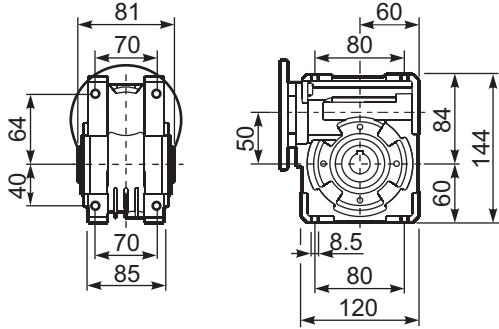

PQ50**BR**... Tork Kolu
Reaction arm

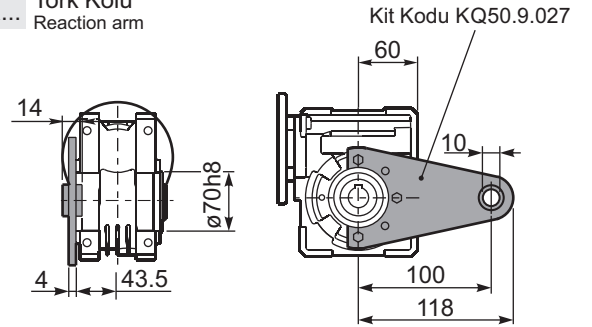

RQ50**FB**... Giriş Mili
Input shaft

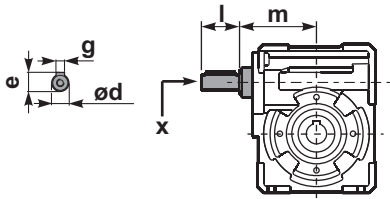

	ød	e	g	l	m	x	Kit Kodu
Tip B	16 h6	18	5	30	79.5	M6x16	① K050.5.006 PAM71 ② K050.5.007 PAM80
Tip S	14 h6	16	5	30	79.5	M5x10	① KS050.5.008 PAM71 ② KS050.5.009 PAM80

PQ50.....**S**... Tek Çıkış Mili
Single Shaft

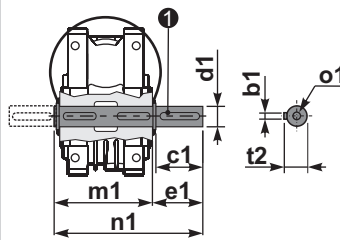

① Kit Kodu K050.5.028 Tip B
Kit Kodu KS050.5.030 Tip S

PQ50.....**D**... Çift Çıkış Mili
Double Shaft

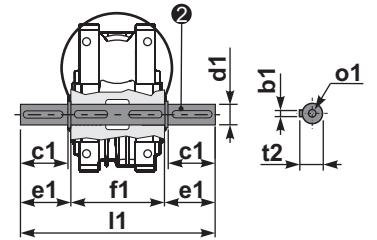

② Kit Kodu K050.5.029 Tip B
Kit Kodu KS050.5.031 Tip S

	b1	c1	d1	e1	f1	l1	m1	n1	t2	o1
Tip B	8	52	25 ^{-0.005} _{-0.020}	59.5	81	200	86.5	146	28	M8x20
Tip S	8	50	24 ^{-0.005} _{-0.020}	68.8	81	218	86.5	155	27	M8x20



HIZLI SEÇİM / Quick Selection

Giriş Devri (n_1) = 1400 d/d

Çıkış devri n_2 [d/d]	Tahvil i	Motor gücü P_{1M} [kW]	Çıkış Momenti M_{2M} [Nm]	Servis Faktörü f.s.	Nominal güç P_{1R} [kW]	Nominal moment M_{2R} [Nm]	Uygun B5 motor Flanşları				Uygun B14 motor flanşları			Dinamik verim RD	Modül [mm]	Tahvil kodu	
							-B	-C	-D	-E	-Q	-R	-T				
							63	71	80	90	71	80	90				
200	7	1.8	71	1.8	3.2	125		B	B			B-C	B-C		83	3.1	01
140	10	1.8	99	1.4	2.4	134		B	B			B-C	B-C		81	3.1	02
93	15	1.5	121	1.1	1.7	138		B	B			B-C	B-C		79	3.1	03
74	19	1.1	111	1.2	1.4	138		B	B			B-C	B-C		78	2.6	04
58	24	1.1	135	1.0	1.2	142		B	B			B-C	B-C		75	2.0	05
47	30	1.1	167	0.9	0.96	146		B	B			B-C	B-C		74	3.2	06
39	36	0.75	125	1.2	0.88	147		B	B			B-C	B-C		68	2.7	07
31	45	0.55	111	1.2	0.67	135	B	B				B-C	C		66	2.1	08
23	60	0.55	140	0.9	0.51	130	B	B				B-C	C		62	1.6	12
21	67	0.55	151	0.8	0.45	124	B	B				B-C	C		60	1.5	09
17.5	80	0.37	115	1.0	0.38	119	B	B				B-C	C		57	1.3	10
14.9	94	0.37	123	1.0	0.36	119	B	B				B-C	C		52	1.1	11

Uygun Motor Flanşları
Motor Flanges Available

B) Burç ile montaj yapılabilir
Supplied with Reduction Bushing

B) Burç Kullanılmadan Montajı Yapılabilir
Available on Request without Reduction Bushing

C) Teminal Kutusu flanş pozisyonu
Motor Flange Holes Position

TR Q63 gövde sonsuz vidalı redüktörler ömürlük sentetik yağ ile yağlanmıştır. V5-V6 montaj pozisyonları için teknik ofisimiz ile iletişime geçiniz. Tablo 1'de uygun yağ seçenekleri ve yağlama miktarları tanımlanmıştır. Tablo 2'de izin verilebilir radyal ve eksenel yükler tanımlanmıştır.

EN Unit Q63 is supplied with synthetic oil, providing "long life" lubrication. For mounting position V5-V6 please contact us. See table 1 for lubrication and recommended quantity. In table 2 please see possible radial loads and axial loads on the gearbox.

YAĞLAMA Q63 Yağ Miktarı 0.30 Lt.
LUBRICATION Q63 Oil Quantity 0.30 Lt.

AGIP Telium VSF 320

SHELL Omala S4 WE 320

Daha fazla ayrıntı için internet sitemizi inceleyiniz.
For all details on lubrication and plugs check our website

Tablo 1

RADYAL VE EKSENEL YÜKLER / RADIAL AND AXIAL LOADS

Çıkış Mili
Output Shaft

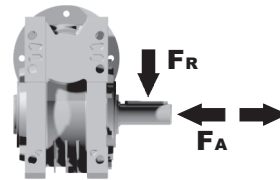

n_2 [d/d]	FA [N]	FR [N]
200	360	1800
150	400	2000
100	460	2300
75	500	2500
50	600	3000
25	700	3800
15	800	4000

Giriş Mili
Input Shaft

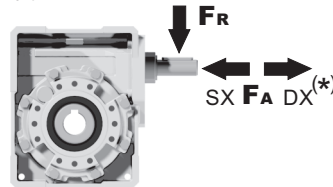

n_1 [d/d]	FA [N]	FR [N]
1400	90	450

*DX yönünde eksenel yüke izin verilmez
Strong axial loads in the DX direction are not allowed.

Tablo 2

PQ63FB... Standart Redüktör
Basic wormbox

Ağırlık
Gearbox
weight **6.00 kg**

M. Flanşlar	Kit Kodu	øF	A
63B5	K063.4.041	140	99.5
71B5	K063.4.042	160	97.5
80/90B5	K063.4.043	200	99.5
71B14	K063.4.047	105	97.5
80B14	K063.4.046	120	99.5
90B14	K063.4.041	140	99.5

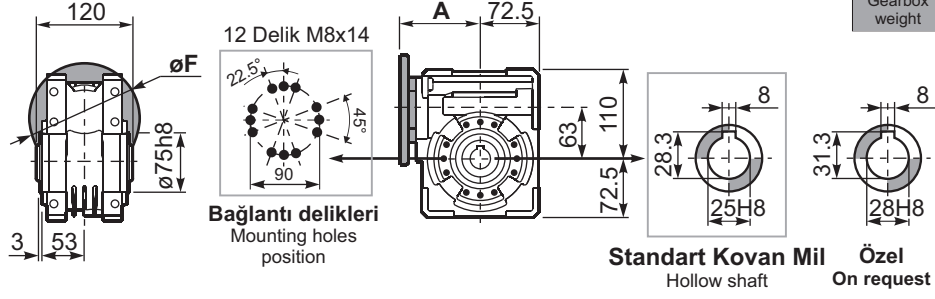

PQ63FC... Kare Çıkış Flanşı
Square flange

PQ63F1... Yuvarlak Çıkış Flanşı
Round flange

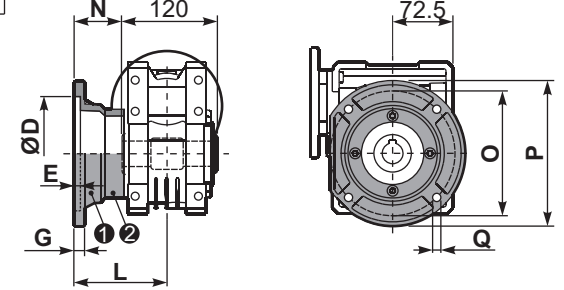
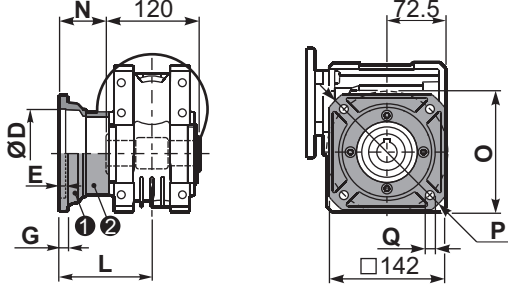

Tip B	øD	E	G	L	N	O	P	Q	Kit Kodu
FC	115 ^{+0.20} / _{+0.15}	6	12	86	26	150	180	11	1 KQ63.9.010 2 -
FL	115 ^{+0.20} / _{+0.15}	6	12	116	56	150	180	11	1 KQ63.9.010 2 K063.0.200

Tip S	øD	E	G	L	N	O	P	Q	Kit Kodu
F1	130 ^{+0.20} / _{+0.15}	7	13	110	50	165	200	13	1 KS070.9.013 2 -
F2	115 ^{+0.20} / _{+0.15}	7	13	124	64	150	175	11	1 KS063.9.013 2 -
F3	110 ^{+0.035} / ₀	5	11	90	30	130	160	10	1 KS063.9.011 2 -

PQ63FB... Ayak
Feet

PQ63BR... Tork Kolu
Reaction arm

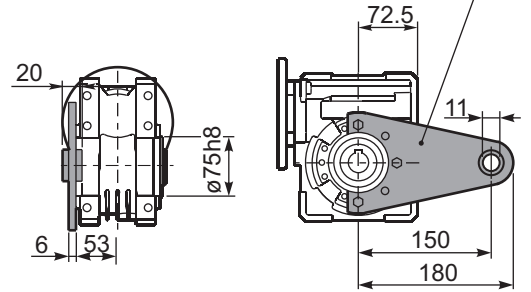
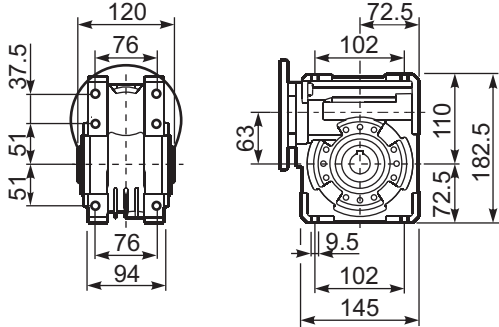

RQ63FB... Giriş Mili
Input shaft

PQ63....S... Tek Çıkış Mili
Single Shaft

PQ63....D... Çift Çıkış Mili
Double Shaft

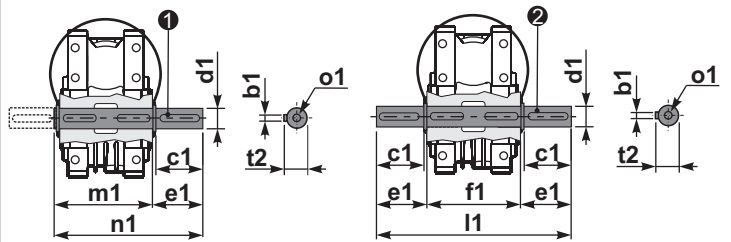
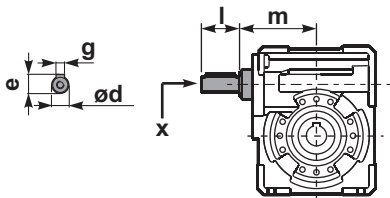

1 Kit Kodu K063.5.028 Tip B

2 Kit Kodu K063.5.029 Tip B

	ød	e	g	l	m	x	Kit Kodu
Tip B	18 h6	20.5	6	45	93	M6x16	1 K063.5.006 PAM80 2 K063.5.007 PAM90
Tip S	19 h6	21.5	6	40	93	M8x20	1 KS063.5.008 PAM80 2 KS063.5.009 PAM90

	b1	c1	d1	e1	f1	l1	m1	n1	t2	o1
Tip B	8	60	25 ^{-0.005} / _{-0.020}	63.2	120	246.4	126.8	190	28	M8x20
Tip S	-	-	-	-	-	-	-	-	-	-



HIZLI SEÇİM / Quick Selection

Giriş Devri (n_1) = 1400 d/d

Çıkış devri n_2 [d/d]	Tahvil i	Motor gücü P_{1M} [kW]	Çıkış Momenti M_{2M} [Nm]	Servis Faktörü f.s.	Nominal güç P_{1R} [kW]	Nominal moment M_{2R} [Nm]	Uygun B5 motor Flanşları				Uygun B14 motor flanşları			Dinamik verim RD	Modül [mm]	Tahvil kodu	
							-C	-D	-E	-F	-R	-T	-U				
							71	80	90	100 112	80	90	100 112				
200	7	4	172	1.1	4.4	190		B	B			B	B		90	3.75	01
140	10	4	240	1.0	3.8	230		B	B			B	B		88	3.75	02
93	15	3	261	1.0	2.9	250		B	B			B	B		85	3.75	03
70	20	2.2	249	1.0	2.2	250		B	B			B	B		83	3.00	04
56	25	1.5	205	1.2	1.8	250	B	B				B			80	2.41	05
45	31	1.5	244	1.1	1.7	270	B	B				B			77	3.75	06
35	40	1.5	295	0.9	1.3	255	B	B				B			72	3.10	07
28	50	0.75	174	1.3	0.95	220	B								68	2.41	08
23	60	0.75	202	1.0	0.75	200	B								65	2.10	09
17.5	80	0.55	177	1.0	0.56	180	B								59	1.53	10
14.0	100	0.55*	206	0.7	0.40	150	B								55	1.23	11

Uygun Motor Flanşları
Motor Flanges Available

B) Burç ile montaj yapılabilir
Supplied with Reduction Bushing

B) Burç Kullanılmadan Montajı Yapılabilir
Available on Request without Reduction Bushing

C) Teminal Kutusu flanş pozisyonu
Motor Flange Holes Position

TR Q75 gövde sonsuz vidalı redüktörler ömürlük sentetik yağ ile yağlanmıştır. V5-V6 montaj pozisyonları için teknik ofisimiz ile iletişime geçiniz. Tablo 1'de uygun yağ seçenekleri ve yağlama miktarları tanımlanmıştır. Tablo 2'de izin verilebilir radyal ve eksenel yükler tanımlanmıştır.

EN Unit Q75 is supplied with synthetic oil, providing "long life" lubrication. For mounting position V5-V6 please contact us. See table 1 for lubrication and recommended quantity. In table 2 please see possible radial loads and axial loads on the gearbox.

YAĞLAMA Q75 Yağ Miktarı 0.40 Lt.
LUBRICATION Q75 Oil Quantity 0.40 Lt.

AGIP Telium VSF 320

SHELL Omala S4 WE 320

Daha fazla ayrıntı için internet sitemizi inceleyiniz.
For all details on lubrication and plugs check our website

Tablo 1

RADYAL VE EKSENEL YÜKLER / RADIAL AND AXIAL LOADS

Çıkış Mili
Output Shaft

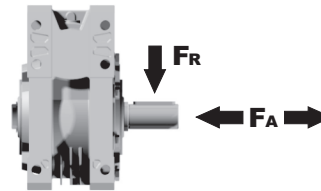

n_2 [d/d]	FA [N]	FR [N]
200	460	2300
150	520	2600
100	560	2800
75	620	3100
50	720	3600
25	880	4400
15	1000	5000

Giriş Mili
Input Shaft

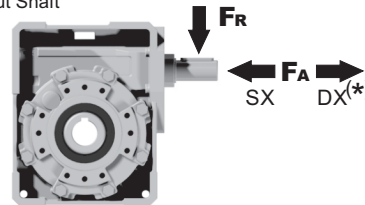

n_1 [d/d]	FA [N]	FR [N]
1400	125	630

*DX yönünde eksenel yüke izin verilmez

Strong axial loads in the DX direction are not allowed.

Tablo 2

PQ75FB... Standart Redüktör
Basic wormbox

Ağırlık
Gearbox
weight **8.70 kg**

M. Flanşlar	Kit Kodu	øF	A
71B5	K023.4.041	160	113.5
80/90B5	K023.4.042	200	115.5
100/112B5	K023.4.043	250	124.5
80B14	K085.4.046	120	115.5
90B14	K085.4.045	140	115.5
100/112B14	K023.4.041	160	113.5

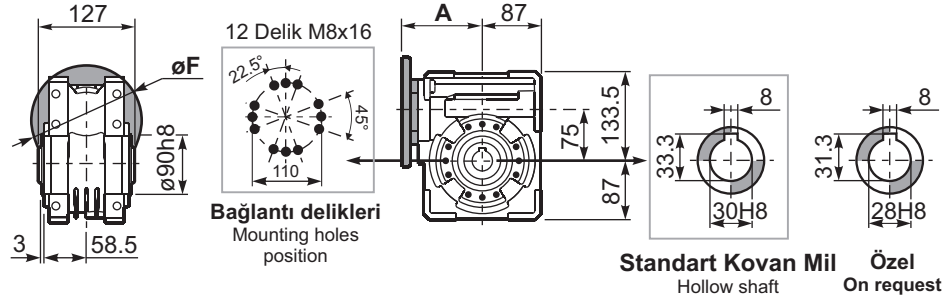

PQ75FC... Kare Çıkış Flanşı
Square flange

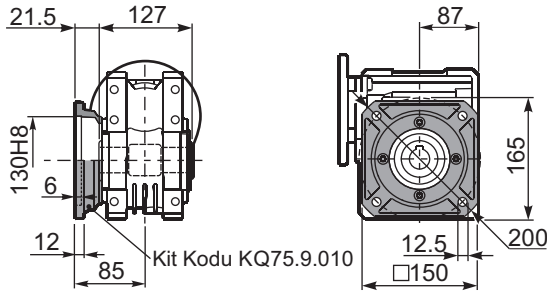

PQ75FL... Yuvarlak Çıkış Flanşı
Round flange

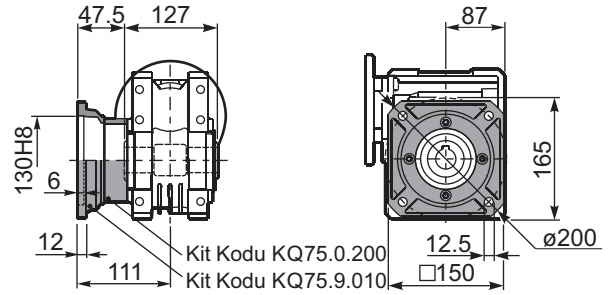

PQ75FB... Ayak
Feet

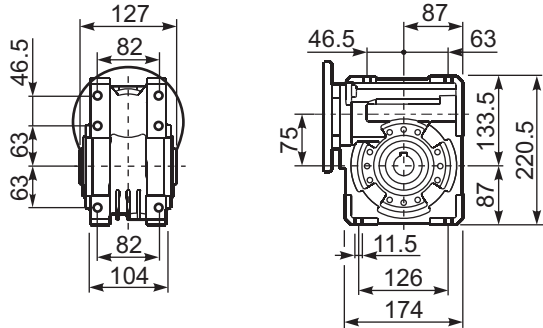

PQ75BR... Tork Kolu
Reaction arm

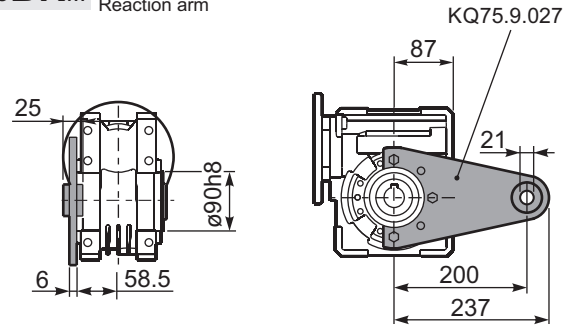

RQ75FB... Giriş Mili
Input shaft

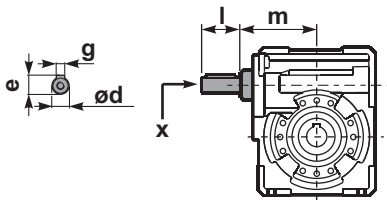

PQ75....S... Tek Çıkış Mili
Single Shaft

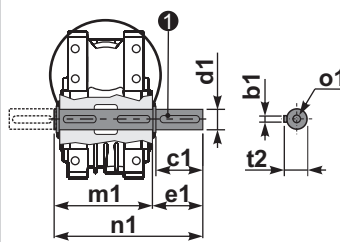

PQ75....D... Çift Çıkış Mili
Double Shaft

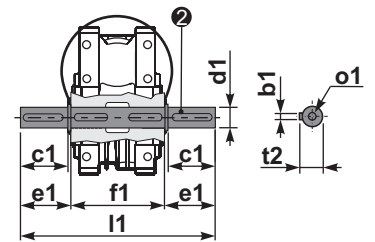

① Kit Kodu KQ75.5.028 Standart Kit Kodu KQ75.5.026 Özel
② Kit Kodu KQ75.5.029 Standart Kit Kodu KQ75.5.027 Özel

	ød	e	g	l	m	x	Kit Kodu
Tip B	25 h6	27.8	8	50	109.5	M8x20	KQ75.5.006 PAM80 K085.5.007 PAM90 K085.5.008 PAM100

	b1	c1	d1	e1	f1	l1	m1	n1	t2	o1
Standart	8	60	30 ^{-0.005/-0.020}	65	127	255	134	199	33	M8x20
Özel	8	60	28 ^{-0.005/-0.020}	65	127	255	134	199	31	M8x20



HIZLI SEÇİM / Quick Selection

Giriş Devri (n₁) = 1400 d/d

Çıkış devri n ₂ [d/d]	Tahvil i	Motor gücü P _{1M} [kW]	Çıkış Momenti M _{2M} [Nm]	Servis Faktörü f.s.	Nominal güç P _{1R} [kW]	Nominal moment M _{2R} [Nm]	Uygun B5 motor Flanşları				Uygun B14 motor flanşları			Dinamik verim RD	Modül [mm]	Tahvil kodu	
							-C	-D	-E	-F	-R	-T	-U				
							71	80	90	100 112	80	90	100 112				
200	7	4.0	168	1.5	6.1	257		B	B			B	B		88	4.23	01
140	10	4.0	218	1.3	5.2	284		B	B			B	B		80	4.2	02
100	14	3.0	223	1.4	4.1	305		B	B			B	B		78	4.5	03
70	20	2.2	237	1.2	2.7	294		B	B			B	B		79	3.4	04
64	22	2.2	258	1.1	2.5	294		B	B			B	B		78	3.1	05
50	28	2.2	315	1.1	2.4	347		B	B			B	B		75	4.7	06
37	38	1.5	276	1.2	1.8	336	B	B				B	B		71	3.5	07
30	46	1.5	320	1.0	1.5	326	B	B				B	B		68	3.1	08
27	52	1.1	258	1.1	1.2	289	B	B				B	B		66	2.7	09
21	67	1.1	327	0.9	0.97	289	B	B				B	B		65	2.1	10
18.9	74	0.75	220	1.2	0.91	268	B	B				B	B		58	1.9	11
14.6	96	0.55	191	1.3	0.70	242	B	B				B	B		53	1.5	12

Uygun Motor Flanşları
Motor Flanges Available

B) Burç ile montaj yapılabilir
Supplied with Reduction Bushing

B) Burç Kullanılmadan Montajı Yapılabilir
Available on Request without Reduction Bushing

C) Teminal Kutusu flanş pozisyonu
Motor Flange Holes Position

TR Q85 gövde sonsuz vidalı redüktörler ömürlük sentetik yağ ile yağlanmıştır. V5-V6 montaj pozisyonları için teknik ofisimiz ile iletişime geçiniz. Tablo 1'de uygun yağ seçenekleri ve yağlama miktarları tanımlanmıştır. Tablo 2'de izin verilebilir radyal ve eksenel yükler tanımlanmıştır.

EN Unit Q85 is supplied with synthetic oil, providing "long life" lubrication. For mounting position V5-V6 please contact us. See table 1 for lubrication and recommended quantity. In table 2 please see possible radial loads and axial loads on the gearbox.

YAĞLAMA Q85 Yağ Miktarı 1.20 Lt.

LUBRICATION Q85 Oil Quantity 1.20 Lt.

AGIP Telium VSF 320

SHELL Omala S4 WE 320

Daha fazla ayrıntı için internet sitemizi inceleyiniz.

For all details on lubrication and plugs check our website

Tablo 1

RADYAL VE EKSENEL YÜKLER / RADIAL AND AXIAL LOADS

Çıkış Mili
Output Shaft

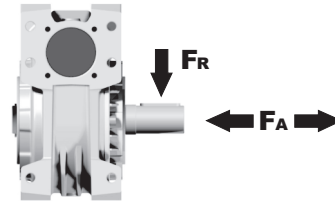

n ₂ [d/d]	FA [N]	FR [N]
200	500	2500
150	580	2900
100	600	3000
75	700	3500
50	800	4000
25	1000	5000
15	1160	5800

Giriş Mili
Input Shaft

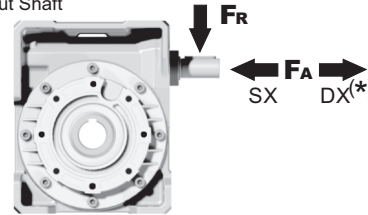

n ₁ [d/d]	FA [N]	FR [N]
1400	160	809

*DX yönünde eksenel yüke izin verilmez

Strong axial loads in the DX direction are not allowed.

Tablo 2

PQ85FB... Standart Redüktör
Basic wormbox

Ağırlık
Gearbox
weight **12.1 kg**

M. Flanşlar	Kit Kodu	øF	A
71B5	K023.4.041	160	116
80/90B5	K023.4.042	200	118
100/112B5	K023.4.043	250	127
80B14	K085.4.046	120	118
90B14	K085.4.045	140	118
100/112B14	K023.4.041	160	116

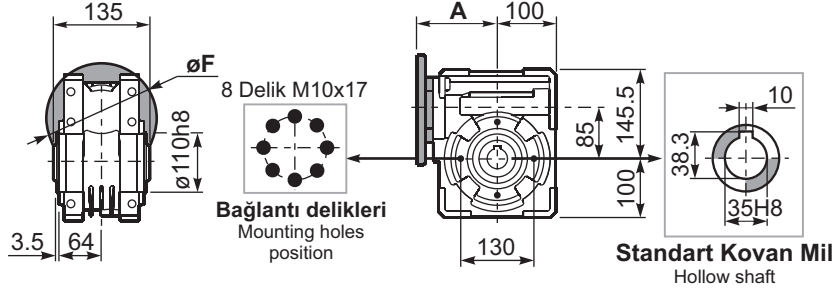

PQ85FC... Kare Çıkış Flanşı
Square flange

PQ85F1... Yuvarlak Çıkış Flanşı
Round flange

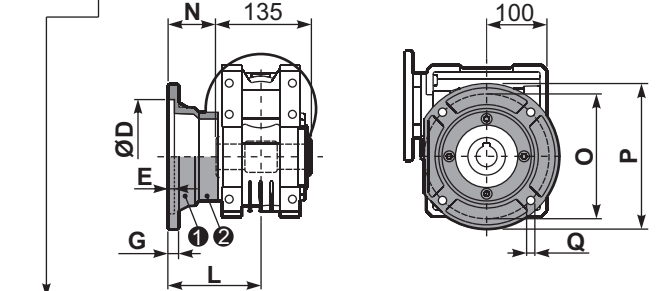
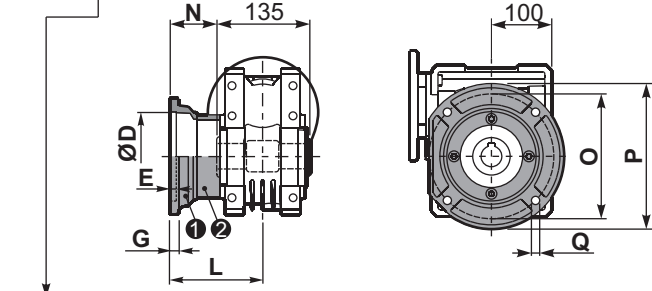

Tip B	øD	E	G	L	N	O	P	Q	Kit Kodu
FC	152 ^{+0.06} / _{+0.00}	5	16	108	40.5	176	205	13	1 K085.9.010 2 -
FL	152 ^{+0.06} / _{+0.00}	5	16	148.5	81	176	205	13	1 K085.9.010 2 K085.0.201

Tip S	øD	E	G	L	N	O	P	Q	Kit Kodu
F1	130 H7	5	13	117.5	50	165	200	11.5	1 KS085.9.012 2 -
F2	152 ^{+0.06} / _{+0.00}	5	15	147.5	80	180	205	12.5	1 KS085.9.013 2 -
F4	130 H7	5	13	106.5	39	165	200	13	1 KS085.9.015 2 -

PQ85FB... Ayak
Feet

PQ85BR... Tork Kolu
Reaction arm

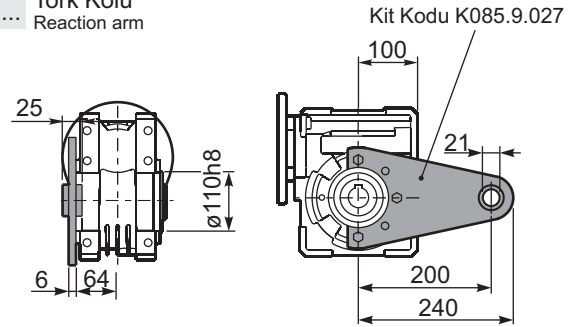
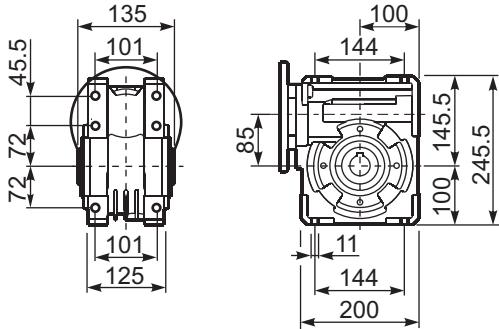

RQ85FB... Giriş Mil
Input shaft

PQ85....S... Tek Çıkış Mil
Single Shaft

PQ85....D... Çift Çıkış Mil
Double Shaft

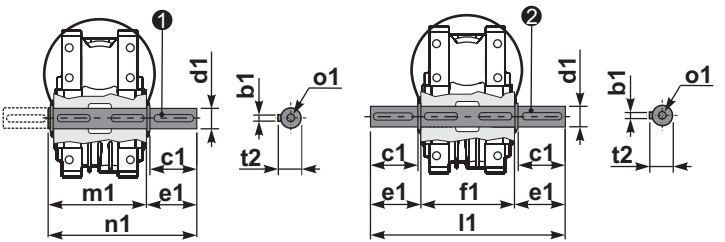
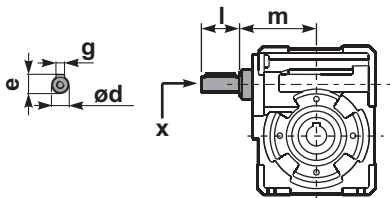

1 Kit Kodu K085.5.028 Tip B

2 Kit Kodu K085.5.029 Tip B

Tip B	ød	e	g	l	m	x	Kit Kodu
Tip B	25 h6	28	8	50	112	M8x20	1 K085.5.007 PAM90 2 K085.5.008 PAM100
Tip S	24 h6	27	8	50	112	M8x20	1 KS085.5.009 PAM90 2 KS085.5.011 PAM100

Tip B	b1	c1	d1	e1	f1	l1	m1	n1	t2	o1
Tip B	10	60	35 ^{-0.005} / _{-0.020}	73.5	135	282	141	214.5	38	M10x23
Tip S	-	-	-	-	-	-	-	-	-	-



HIZLI SEÇİM / Quick Selection

Giriş Devri (n_1) = 1400 d/d

Çıkış devri n_2 [d/d]	Tahvil i	Motor gücü P_{1M} [kW]	Çıkış Momenti M_{2M} [Nm]	Servis Faktörü f.s.	Nominal güç P_{1R} [kW]	Nominal moment M_{2R} [Nm]	Uygun B5 motor Flanşları					Uygun B14 motor flanşları				Dinamik verim RD	Modül [mm]	Tahvil kodu		
							-C	-D	-E	-F	-G	-R	-T	-U	-V					
							71	80	90	100 112	132	80	90	100 112	132					
200	7	7.5	315	1.5	11.5	483		B	B					B	B			88	5.5	01
140	10	7.5	440	1.2	9.0	525		B	B					B	B			86	5.4	02
88	16	5.5	492	1.1	6.0	536		B	B					B	B			82	5.3	03
70	20	4.0	447	1.2	4.9	546		B	B					B	B			82	4.5	04
61	23	3.0	377	1.4	4.1	515		B	B					B	B			80	3.9	05
47	30	3.0	467	1.4	4.2	651		B	B					B	B			76	5.6	06
37	38	3.0	583	1.1	3.3	641		B	B					B	B			75	4.7	07
31	45	2.2	493	1.2	2.7	599		B	B					B	B			73	4.0	08
26	53	2.2	557	1.1	2.5	620		B	B					B	B			70	3.5	09
22	64	1.5	452	1.2	1.8	536	B	B						B	B			69	2.9	10
16.7	84	1.1	410	1.2	1.3	494	B	B						B	B			65	2.2	11
14.1	99	1.1	446	1.1	1.2	483	B	B						B	B			60	1.9	12

Uygun Motor Flanşları
Motor Flanges Available

B) Burç ile montaj yapılabilir
Supplied with Reduction Bushing

B) Burç Kullanılmadan Montajı Yapılabilir
Available on Request without Reduction Bushing

C) Teminal Kutusu flanş pozisyonu
Motor Flange Holes Position

TR Q11 gövde redüktörler yağsız olarak sevk edilir. Redüktör üzerinde havalandırma tapası, yağ göstergesi ve tahliye tapası mevcuttur. Mineral yağlar bu ekipmanlar ile birlikte kullanılır. Sentetik yağ kullanılmak istenirse bu ekipmanların körtapa ile değiştirilmesi önerilir. Tablo 1'de montaj pozisyonuna göre uygun yağ miktarları tanımlanmıştır. Tablo 2'de izin verilebilir radyal ve aksenal yük değerleri tanımlanmıştır.

EN Unit Q11 is supplied without lubricant and equipped with a breather, level and drain plugs. User can add mineral oil keeping existing plugs. Should the user wish to fill it with synthetic oil, it is recommended to replace the existing plugs with a closed plug. See table 1 for lubrication and recommended quantity. In table 2 please see possible radial loads and axial loads on the gearbox.

B3	B6	B7	B8	V5	V6
2.00 LT	1.35 LT	1.35 LT	2.00LT	2.00 LT	2.00LT

AGIP Blasia 460

Daha fazla ayrıntı için internet sitemizi inceleyiniz.
For all details on lubrication and plugs check our website

Tablo 1

RADYAL VE EKSENEL YÜKLER / RADIAL AND AXIAL LOADS

Çıkış Mili
Output Shaft

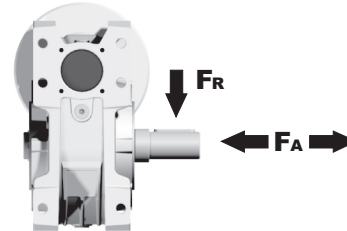

n_2 [d/d]	FA [N]	FR [N]
200	600	2900
150	700	3300
100	750	3600
75	800	4000
50	920	4600
25	1200	6000
15	1400	7000

Giriş Mili
Input Shaft

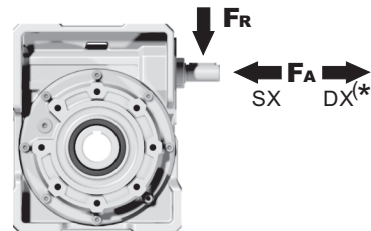

n_1 [d/d]	FA [N]	FR [N]
1400	228	1140

*DX yönünde aksenal yüke izin verilmez.
Strong axial loads in the DX direction are not allowed.

Tablo 2

PQ11FB... Standart Redüktör
Basic wormbox

Ağırlık
Gearbox
weight **35.0 kg**

M. Flanşlar	Kit Kodu	øF	A
71B5	K023.4.041	160	135.5
80/90B5	K023.4.042	200	137.5
100/112B5	K023.4.043	250	146.5
132B5	-	300	187
80B14	K085.4.046	120	137.5
90B14	K085.4.045	140	137.5
100/112B14	K023.4.041	160	135.5
132B14	-	200	187

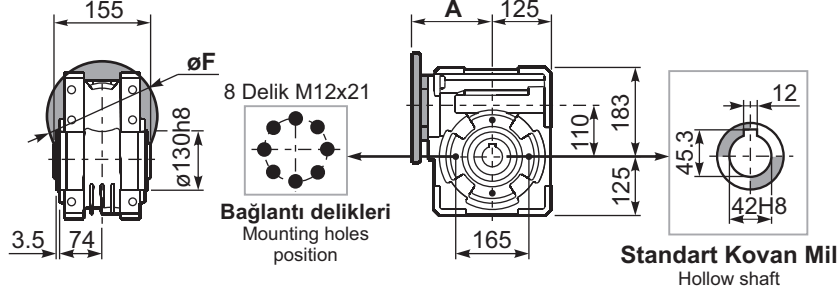

PQ11FC... Kare Çıkış Flanşı
Square flange

PQ11F1... Yuvarlak Çıkış Flanşı
Round flange

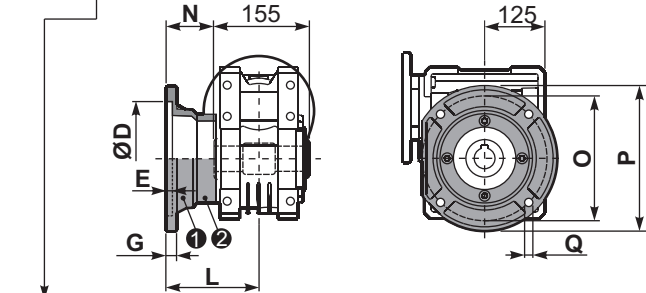
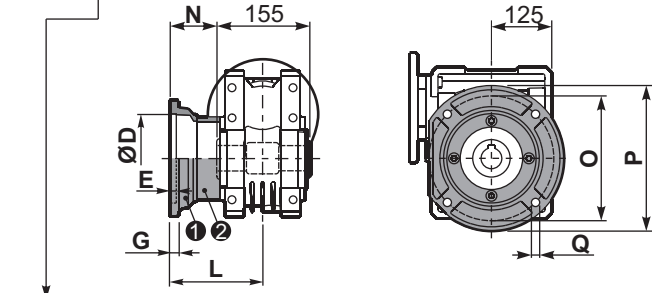

Tip B	øD	E	G	L	N	O	P	Q	Kit Kodu
FC	170 ^{+0.083} _{+0.043}	11	16.5	131.5	54	230	270	13	1 K110.9.010 2 -
FL	170 ^{+0.083} _{+0.043}	11	16.5	179.5	102	230	270	13	1 K110.9.011 2 -

Tip S	øD	E	G	L	N	O	P	Q	Kit Kodu
F1	180 ^{+0.040} ₀	5	18	150	72.5	215	250	15	1 KS110.9.014 2 -
F2	170 ^{+0.083} _{+0.043}	9.5	15	178	100.5	230	270	13	1 KS110.9.012 2 -
F3	180 ^{+0.040} ₀	5	18	130	52.5	215	250	15	1 KS110.9.013 2 -

PQ11FB... Ayak
Feet

PQ11BR... Tork Kolu
Reaction arm

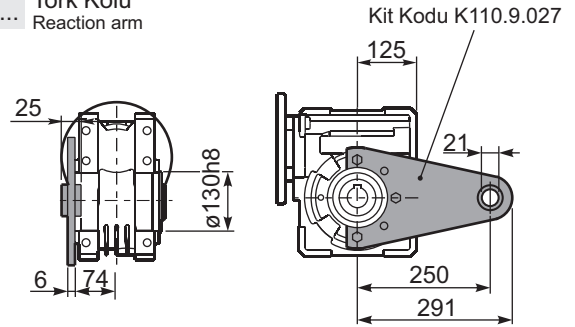
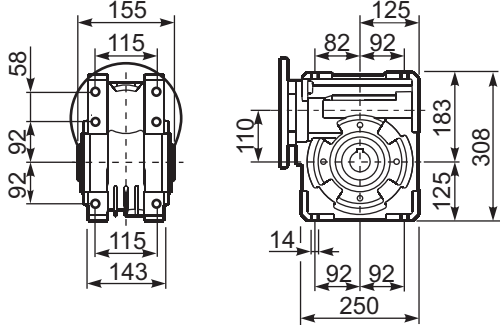

RQ11FB... Giriş Mili
Input shaft

PQ11.....S... Tek Çıkış Mili
Single Shaft

PQ11.....D... Çift Çıkış Mili
Double Shaft

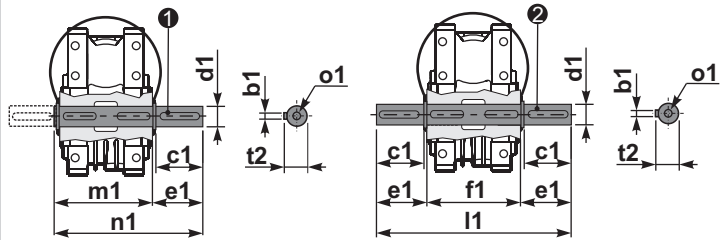
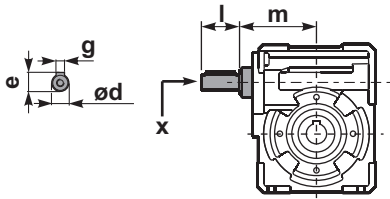

1 Kit Kodu K110.5.028 Tip B

2 Kit Kodu K110.5.029 Tip B

	ød	e	g	l	m	x	Kit Kodu
Tip B	25 h6	28	8	50	131.5	M8x20	1 K085.5.007 PAM90 2 K085.5.008 PAM100
Tip S	24 h6	27	8	50	131.5	M8x20	1 KS085.5.009 PAM90 2 KS085.5.011 PAM100

	b1	c1	d1	e1	f1	l1	m1	n1	t2	o1
Tip B	12	75	42 ^{-0.005} _{-0.020}	96.5	155	348	163.5	260	45	M12x32
Tip S	-	-	-	-	-	-	-	-	-	-



HIZLI SEÇİM / Quick Selection

Giriş Devri (n_1) = 1400 d/d

Çıkış devri n_2 [d/d]	Tahvil i	Motor gücü P_{1M} [kW]	Çıkış Momenti M_{2M} [Nm]	Servis Faktörü f.s.	Nominal güç P_{1R} [kW]	Nominal moment M_{2R} [Nm]	Uygun B5 motor Flanşları			Uygun B14 motor flanşları				Dinamik verim RD	Modül [mm]	Tahvil kodu	
							-E	-F	-G	-	-	-	-				
							90	100 112	132	-	-	-	-				
187	7.5	7.5	345	2.1	16.1	741											
140	10	7.5	455	1.8	13.5	820											
93	15	7.5	668	1.4	10.3	917											
70	20	7.5	870	1.0	7.8	905											
56	25	5.5	788	1.2	6.5	931											
46.7	30	5.5	900	1.2	6.4	1047											
35	40	4.0	851	1.2	4.9	1043											
28	50	4.0	1023	0.9	3.8	972											
23.3	60	3.0	896	1.0	3.1	928											
17.5	80	2.2	816	1.0	2.3	853											
14	100	1.5	655	1.1	1.7	742											

2

Uygun Motor Flanşları
Motor Flanges Available

B) Burç ile montaj yapılabilir
Supplied with Reduction Bushing

B) Burç Kullanılmadan Montajı Yapılabilir
Available on Request without Reduction Bushing

C) Teminal Kutusu flanş pozisyonu
Motor Flange Holes Position

TR Q13 gövde redüktörler yağsız olarak sevk edilir. Redüktör üzerinde havalandırma tapası, yağ göstergesi ve tahliye tapası mevcuttur. Mineral yağlar bu ekipmanlar ile birlikte kullanılır. Sentetik yağ kullanılmak istenirse bu ekipmanların körtapa ile değiştirilmesi önerilir. Tablo 1'de montaj pozisyonuna göre uygun yağ miktarları tanımlanmıştır. Tablo 2'de izin verilebilir radyal ve eksenel yük değerleri tanımlanmıştır.

B3	B6	B7	B8	V5	V6
4.50 LT	3.50 LT	3.50 LT	3.30LT	4.50 LT	3.30LT

AGIP Blasias 460

Daha fazla ayrıntı için internet sitemizi inceleyiniz.
For all details on lubrication and plugs check our website

Tablo 1

EN Unit Q13 is supplied without lubricant and equipped with a breather, level and drain plugs. User can add mineral oil keeping existing plugs. Should the user wish to fill it with synthetic oil, it is recommended to replace the existing plugs with a closed plug. See table 1 for lubrication and recommended quantity. In table 2 please see possible radial loads and axial loads on the gearbox.

RADYAL VE EKSENEL YÜKLER / RADIAL AND AXIAL LOADS

Çıkış Mili
Output Shaft

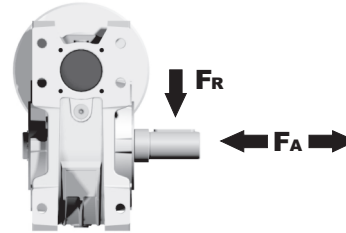

n_2 [d/d]	FA [N]	FR [N]
200	960	4800
150	1100	5500
100	1240	6200
75	1380	6900
50	1560	7800
25	2000	10000
15	2400	12000

Giriş Mili
Input Shaft

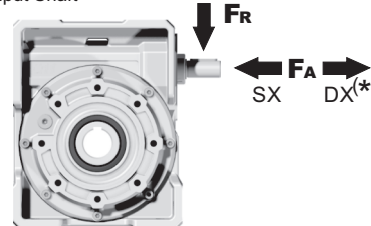

n_1 [d/d]	FA [N]	FR [N]
1400	300	1500

*DX yönünde eksenel yüke izin verilmez
Strong axial loads in the DX direction are not allowed.

Tablo 2

PQ13FB... Standart Redüktör
Basic wormbox

Ağırlık
Gearbox
weight **48.0 kg**

M. Flanşları	Kit Kodu	øF	A
90B5	KQ13.4.041	200	180
100/112B5	KQ13.4.042	250	180
132B5	KQ13.4.043	300	180

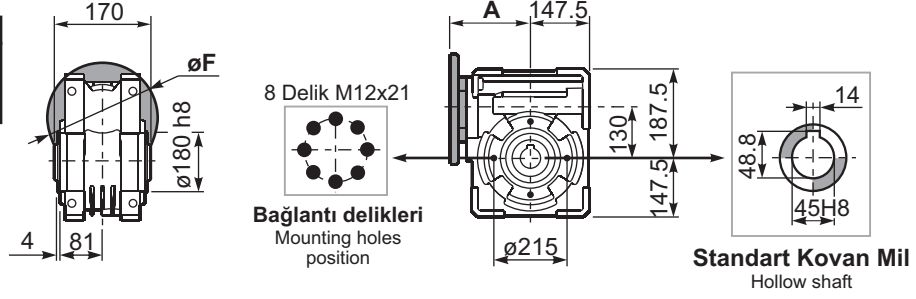

PQ13FC... Kare Çıkış Flanşı
Square flange

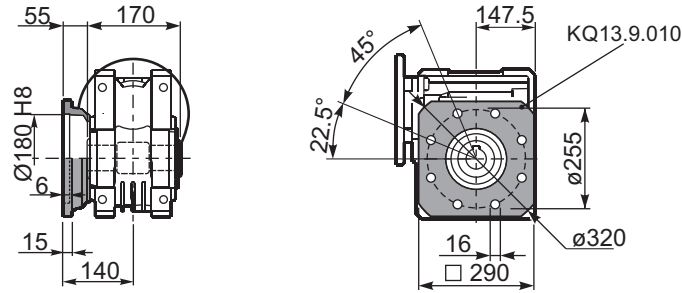

PQ13FB... Ayak
Feet

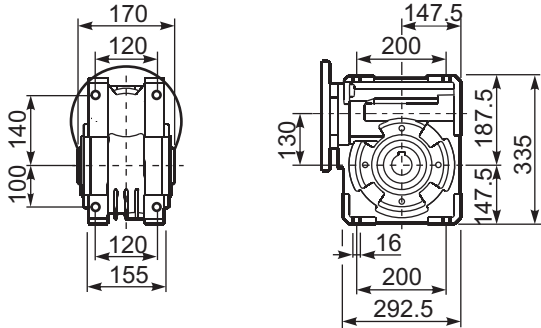

PQ13BR... Tork Kolu
Reaction arm

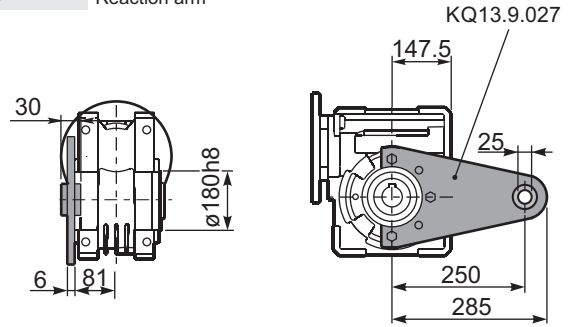

PQ13....S... Tek Çıkış Mili
Single Shaft

PQ13....D... Çift Çıkış Mili
Double Shaft

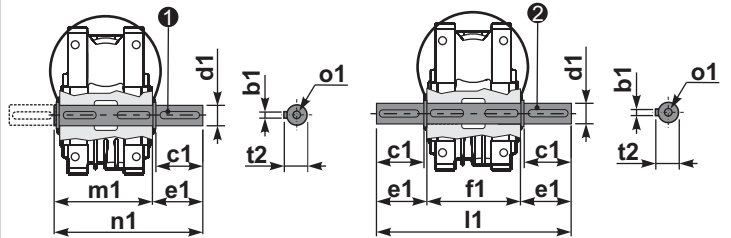

① Kit Kodu KQ13.5.028 Tip B

② Kit Kodu KQ13.5.029 Tip B

	b1	c1	d1	e1	f1	l1	m1	n1	t2	o1
Tip	14	80	45 ^{-0.005} _{-0.020}	85	170	340	180	265	48.5	M16
Tip	-	-	-	-	-	-	-	-	-	-



HIZLI SEÇİM / Quick Selection

Giriş Devri (n_1) = 1400 d/d

Çıkış devri n_2 [d/d]	Tahvil i	Motor gücü P_{1M} [kW]	Çıkış Momenti M_{2M} [Nm]	Servis Faktörü f.s.	Nominal güç P_{1R} [kW]	Nominal moment M_{2R} [Nm]	Uygun B5 motor Flanşları			Uygun B14 motor flanşları				Dinamik verim RD	Modül [mm]	Tahvil kodu
							-F	-G	-H	-	-	-	-			
							100	132	160	-	-	-	-			
187	7.5	15	698	1.7	25.8	1200			B					91	5.5	01
140	10	15	921	1.3	20.2	1240			B					90	6.155	02
93	15	11	990	1.3	13.9	1250			B					88	5.5	03
70	20	11	1291	1.0	11.1	1300			B					86	6.155	04
56	25	9	1289	0.9	8.4	1200			B					84	5	05
46.7	30	7.5	1274	0.9	7.1	1200	B							83	4.193	06
35	40	7.5	1596	1.0	7.3	1550	B							78	6.155	07
28	50	5.5	1426	1.0	5.4	1400	B							76	5	08
23.3	60	4	1195	1.1	4.2	1260	B							73	4.193	09
17.5	80	3	1113	1.0	3.1	1150								68	3.17	10
14	100	2.2	960	1.0	2.3	1000								64	2.55	11

Uygun Motor Flanşları
Motor Flanges Available

B) Burç ile montaj yapılabilir
Supplied with Reduction Bushing

B) Burç Kullanılmadan Montajı Yapılabilir
Available on Request without Reduction Bushing

C) Teminal Kutusu flanş pozisyonu
Motor Flange Holes Position

TR Q15 gövde redüktörler yağsız olarak sevk edilir. Redüktör üzerinde havalandırma tapası, yağ göstergesi ve tahliye tapası mevcuttur. Mineral yağlar bu ekipmanlar ile birlikte kullanılır. Sentetik yağ kullanılmak istenirse bu ekipmanların körtapa ile değiştirilmesi önerilir. Tablo 1'de montaj pozisyonuna göre uygun yağ miktarları tanımlanmıştır. Tablo 2'de izin verilebilir radyal ve aksel yük değerleri tanımlanmıştır.

B3	B6	B7	B8	V5	V6
7.00 LT	5.40 LT	5.40 LT	5.10 LT	7.00 LT	5.10 LT

AGIP Blasias 460

Daha fazla ayrıntı için internet sitemizi inceleyiniz.
For all details on lubrication and plugs check our website

Tablo 1

EN Unit Q15 is supplied without lubricant and equipped with a breather, level and drain plugs. User can add mineral oil keeping existing plugs. Should the user wish to fill it with synthetic oil, it is recommended to replace the existing plugs with a closed plug. See table 1 for lubrication and recommended quantity. In table 2 please see possible radial loads and axial loads on the gearbox.

RADYAL VE EKSENEL YÜKLER / RADIAL AND AXIAL LOADS

Çıkış Mili
Output Shaft

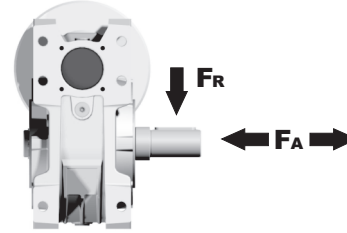

n_2 [d/d]	FA [N]	FR [N]
200	1300	6500
150	1440	7200
100	1640	8200
75	1800	9000
50	2120	10600
25	2700	13500
15	3300	16500

Giriş Mili
Input Shaft

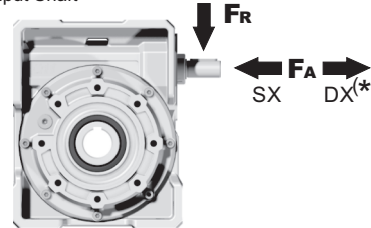

n_1 [d/d]	FA [N]	FR [N]
1400	400	2000

*DX yönünde aksel yüküne izin verilmez
Strong axial loads in the DX direction are not allowed.

Tablo 2

PQ15**FB**... Standart Redüktör
Basic wormbox

Ağırlık
Gearbox
weight **84.0 kg**

M. Flanşlar	Kit Kodu	øF	A
100/112B5	KQ15.4.042	250	210
132B5	KQ15.4.043	300	210
160B5	KQ15.4.044	350	210

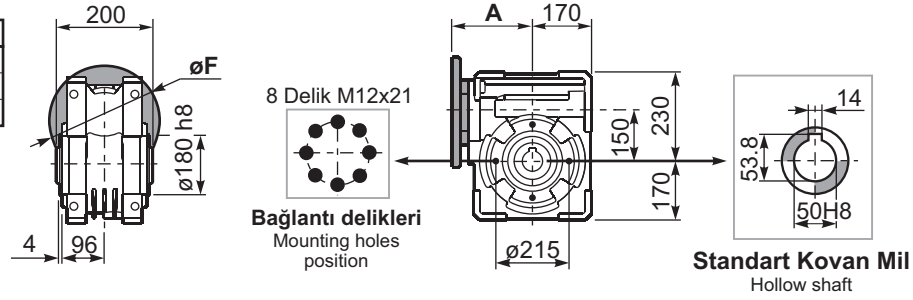

PQ15**FC**... Kare Çıkış Flanşı
Square flange

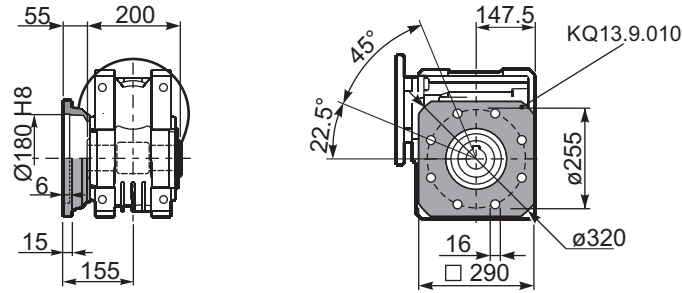

PQ15**FB**... Ayak
Feet

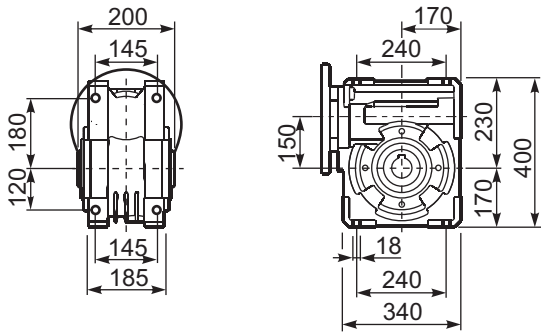

PQ15**BR**... Tork Kolu
Reaction arm

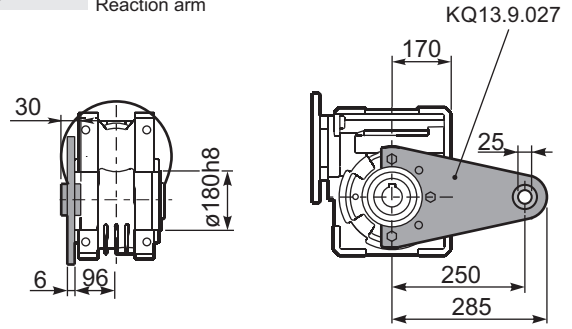

PQ15.....**S**... Tek Çıkış Mili
Single Shaft

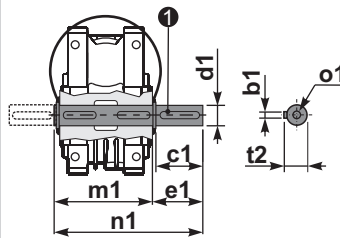

PQ15.....**D**... Çift Çıkış Mili
Double Shaft

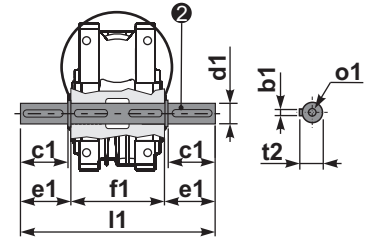

① Kit Kodu KQ15.5.028 Tip B

② Kit Kodu KQ15.5.029 Tip B

	b1	c1	d1	e1	f1	l1	m1	n1	t2	o1
Tip	14	82	50 ^{-0.005} _{-0.020}	87	200	374	210	297	53.5	M16
Tip	-	-	-	-	-	-	-	-	-	-



HIZLI SEÇİM / Quick Selection

Giriş Devri (n_1) = 1400 d/d

Çıkış devri n_2 [d/d]	Tahvil i	Motor gücü P_{1M} [kW]	Çıkış Momenti M_{2M} [Nm]	Servis Faktörü f.s.	Nominal güç P_{1R} [kW]	Nominal moment M_{2R} [Nm]	Uygun B5 motor Flanşları			Uygun B14 motor flanşları		Dinamik verim RD	Modül [mm]	Tahvil kodu
							-A	-B	-C	-P	-Q			
							56	63	71	63	71			
47	30.1	0.25	38	1.4	0.36	55				C		74	2.2	01
33	43.0	0.25	53	1.0	0.26	55				C		72	2.2	02
23	60.2	0.25	62	0.9	0.22	55				C		60	2.4	03
15.5	90.3	0.12	42	1.3	0.16	55				C		57	1.6	04
11.6	120	0.12	52	1.1	0.13	55				C		53	2.5	05
8.8	159	0.12	64	0.9	0.10	55				C		49	1.8	06
7.1	198	0.12*	55	<0.8	0.09	55				C		47	1.5	07
5.4	258	0.12*	55	<0.8	0.07	55				C		45	1.2	08
4.7	301	0.12*	39	<0.8	0.05	39				C		40	1.0	09
3.2	439	0.12*	39	<0.8	0.04	39				C		36	0.72	10

Uygun Motor Flanşları
Motor Flanges Available

B) Burç ile montaj yapılabilir
Supplied with Reduction Bushing

B) Burç Kullanılmadan Montajı Yapılabilir
Available on Request without Reduction Bushing

C) Teminal Kutusu flanş pozisyonu
Motor Flange Holes Position

* Tablolarda verilen değerlerin üzerindeki motor güçleri için seçimleri M_{2R} değerini referans alarak yapınız.
Power higher than the maximum one which can be supported by the gearbox. Select according to the torque M_{2R}

TR P4Q gövde sonsuz vidalı redüktörler ömürlük sentetik yağ ile yağlanmıştır. V5-V6 montaj pozisyonları için teknik ofisimiz ile iletişime geçiniz. Tablo 1'de uygun yağ seçenekleri ve yağlama miktarları tanımlanmıştır. Tablo 2'de izin verilebilir radyal ve aksel yükler tanımlanmıştır.

EN Unit P4Q is supplied with synthetic oil, providing "long life" lubrication. For mounting position V5-V6 please contact us. See table 1 for lubrication and recommended quantity. In table 2 please see possible radial loads and axial loads on the gearbox.

YAĞLAMA

Ortak Yağlama 0.17 l (A + B).
LUBRICATION

Common Lubrication 0.17 l (A + B).

AGIP Telium VSF 320

SHELL Omala S4 WE 320

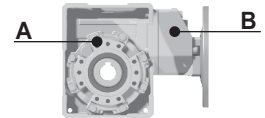

Daha fazla ayrıntı için internet sitemizi inceleyiniz.
For all details on lubrication and plugs check our website

Tablo 1

RADYAL VE EKSENEL YÜKLER / RADIAL AND AXIAL LOADS

Çıkış Mili

Output Shaft

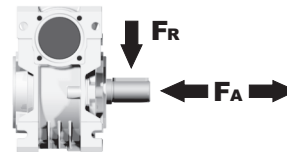

n_2 [d/d]	FA [N]	FR [N]
75	240	1200
50	260	1400
25	300	1800
15-6	400	2000

Giriş Mili

Input Shaft

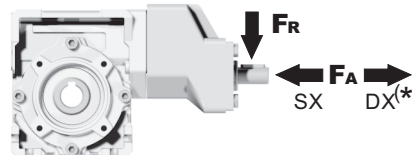

n_1 [d/d]	FA [N]	FR [N]
1400	44	220

*DX yönünde aksel yükü izin verilmez
Strong axial loads in the DX direction are not allowed.

Tablo 2

PP4QFB...

M. Flanşlar	Kit Kodu	øF	A
56B5	K050.4.046	120	143.5
63B5	K050.4.041	138	145.5
71B5	K050.4.042	160	143
63B14	K050.4.047	90	145.5
71B14	K050.4.045	105	143

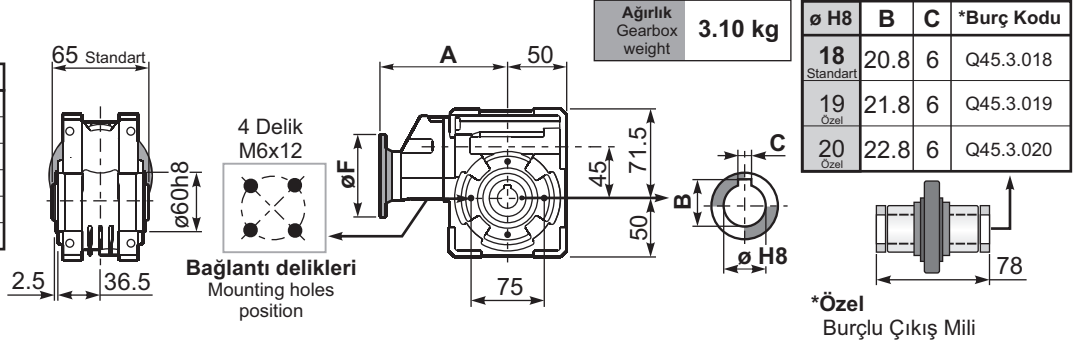

ø H8	B	C	*Burç Kodu
18 Standart	20.8	6	Q45.3.018
19 Özel	21.8	6	Q45.3.019
20 Özel	22.8	6	Q45.3.020

*Özel
Burçlu Çıkış Mili

PP4QFC...

Kare Çıkış Flanşı
Square flange

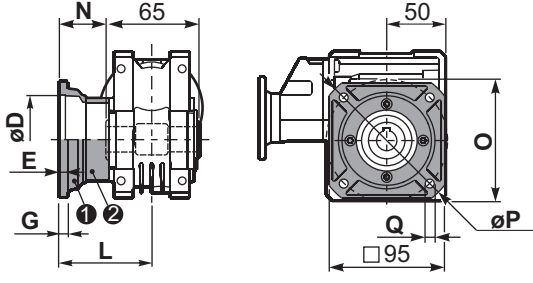

Tip B	øD	E	G	L	N	O	P	Q	Kit Kodu
FC	60 H8	4	7	67	34.5	75	110	9	KQ45.9.010
FL	60 H8	4	7	97	64.5	75	110	9	KQ45.9.011

PP4QF1...

Yuvarlak Çıkış Flanşı
Round flange

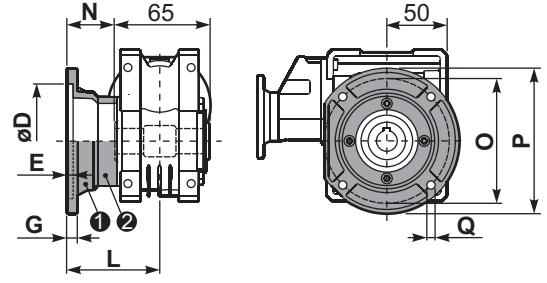

Tip S	øD	E	G	L	N	O	P	Q	Kit Kodu
F1	95H8	5	9	80	47.5	115	140	9.5	KSQ45.9.012
F2	80H8	5	12	58	25.5	100	120	9	KSQ45.9.013

PP4QFB...

Ayak
Feet

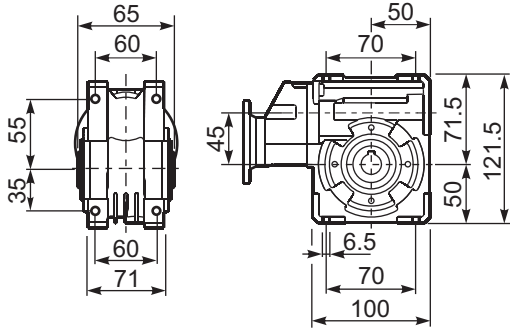

PP4QBR...

Tork Kolu
Reaction arm

Kit Kodu KQ45.9.027

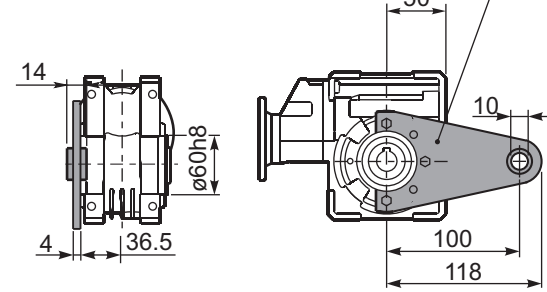

RP4QFB...

Giriş Mili
Input shaft

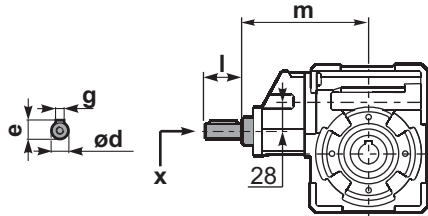

	ød	e	g	l	m	x	
Tip B	14 h6	16	5	25	141	M5x13	C35.5.061
Tip S	-	-	-	-	-	-	

PP4Q.....S...

Tek Çıkış Mili
Single Shaft

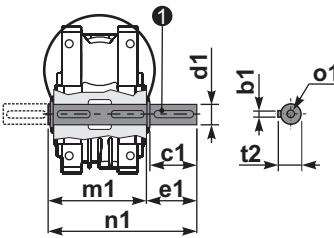

1 Kit Kodu K045.5.028 Tip B
Kit Kodu KS045.5.030 Tip S

PP4Q.....D...

Çift Çıkış Mili
Double Shaft

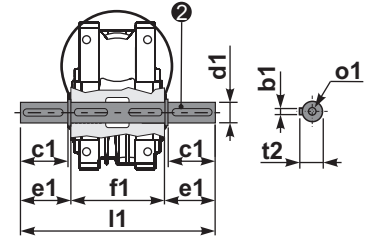

2 Kit Kodu K045.5.029 Tip B
Kit Kodu KS045.5.031 Tip S

	b1	c1	d1	e1	f1	l1	m1	n1	t2	o1
Tip B	6	32	18 ^{-0.005} _{-0.020}	43	65	151	70	113	20.5	M6x18
Tip S	6	40	19 ^{-0.005} _{-0.020}	58.5	65	182	70	128.5	21.5	M8x20



HIZLI SEÇİM / Quick Selection

Giriş Devri (n_1) = 1400 d/d

Çıkış devri n_2 [d/d]	Tahvil i	Motor gücü P_{1M} [kW]	Çıkış Momenti M_{2M} [Nm]	Servis Faktörü f.s.	Nominal güç P_{1R} [kW]	Nominal moment M_{2R} [Nm]	Uygun B5 motor Flanşları			Uygun B14 motor flanşları		Dinamik verim RD	Modül [mm]	Tahvil kodu
							-A	-B	-C	-P	-Q			
							56	63	71	63	71			
47	30.1	0.37	58	1.3	0.49	77				C		76	2.5	01
33	43.0	0.25	55	1.4	0.35	77				C		75	2.4	02
23	60.2	0.25	71	1.1	0.27	77				C		69	2.6	03
18.1	77.4	0.25	81	1.1	0.27	88				C		61	2.0	04
12.5	112	0.18	84	1.1	0.19	88				C		61	2.7	05
9.0	155	0.12	71	1.2	0.15	88				C		56	2.1	06
7.6	185	0.12	74	1.0	0.12	77				C		49	1.8	07
5.4	258	0.12*	77	<0.8	0.09	77				C		47	1.3	08
4.8	292	0.12*	66	<0.8	0.08	66				C		44	1.2	09
4.1	344	0.12*	44	<0.8	0.05	44				C		40	1.0	10
3.3	430	0.12*	44	<0.8	0.04	44				C		36	0.8	11

Uygun Motor Flanşları
Motor Flanges Available

B) Burç ile montaj yapılabilir
Supplied with Reduction Bushing

B) Burç Kullanılmadan Montajı Yapılabilir
Available on Request without Reduction Bushing

C) Teminal Kutusu flanş pozisyonu
Motor Flange Holes Position

* Tablolarda verilen değerlerin üzerindeki motor güçleri için seçimleri M_{2R} değerini referans olarak yapınız.
Power higher than the maximum one which can be supported by the gearbox. Select according to the torque M_{2R}

TR P5Q gövde sonsuz vidalı redüktörler ömürlük sentetik yağ ile yağlanmıştır. V5-V6 montaj pozisyonları için teknik ofisimiz ile iletişime geçiniz.
Tablo 1'de uygun yağ seçenekleri ve yağlama miktarları tanımlanmıştır.
Tablo 2'de izin verilebilir radyal ve eksenel yükler tanımlanmıştır.

EN Unit P5Q is supplied with synthetic oil, providing "long life" lubrication. For mounting position V5-V6 please contact us.
See table 1 for lubrication and recommended quantity.
In table 2 please see possible radial loads and axial loads on the gearbox.

YAĞLAMA

Ortak Yağlama 0.26 lt (A + B).
LUBRICATION
Common Lubrication 0.26 lt (A + B).

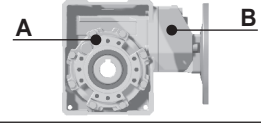

AGIP Telium VSF 320

SHELL Omala S4 WE 320

Daha fazla ayrıntı için internet sitemizi inceleyiniz.
For all details on lubrication and plugs check our website

Tablo 1

RADYAL VE EKSENEL YÜKLER / RADIAL AND AXIAL LOADS

Çıkış Mili Output Shaft

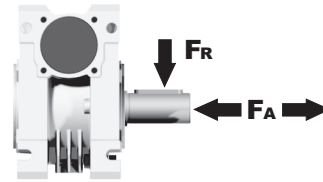

n_2 [d/d]	FA [N]	FR [N]
75	340	1700
50	380	1900
25	480	2500
15-6	560	2800

Giriş Mili Input Shaft

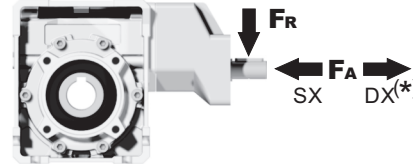

n_1 [d/d]	FA [N]	FR [N]
1400	44	220

*DX yönünde eksenel yüke izin verilmez
Strong axial loads in the DX direction are not allowed.

Tablo 2

PP5QFB... Standart Redüktör
Basic wormbox

M. Flanşlar	Kit Kodu	øF	A
56B5	K050.4.046	120	147
63B5	K050.4.041	138	149
71B5	K050.4.042	160	146.5
63B14	K050.4.047	90	149
71B14	K050.4.045	105	146.5

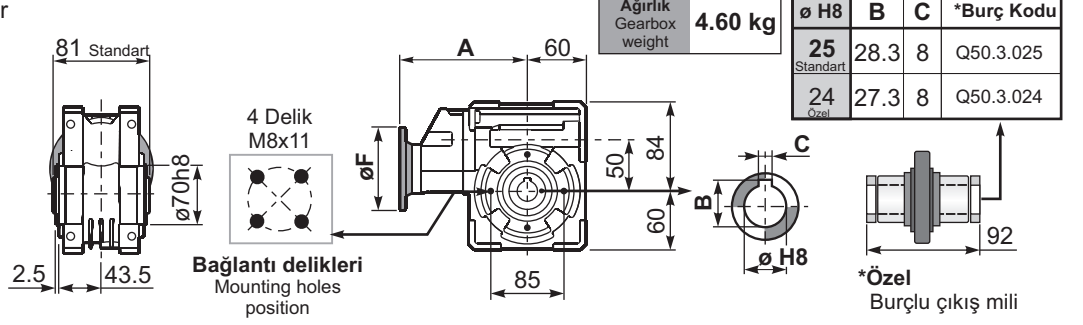

PP5QFC... Kare Çıkış Flanşı
Square flange

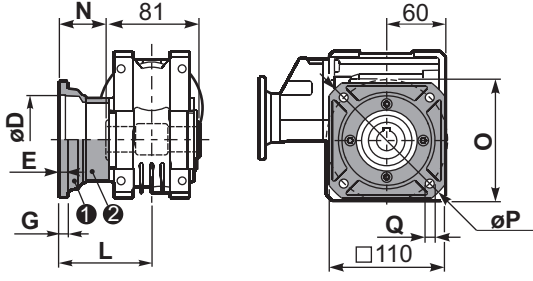

Tip B	øD	E	G	L	N	O	P	Q	Kit Kodu
FC	70 H8	5	9	90	49.5	85	125	11	KQ50.9.010
FL	70 H8	5	9	120	79.5	85	125	11	KQ50.9.011

PP5QF1... Yuvarlak Çıkış Flanşı
Round flange

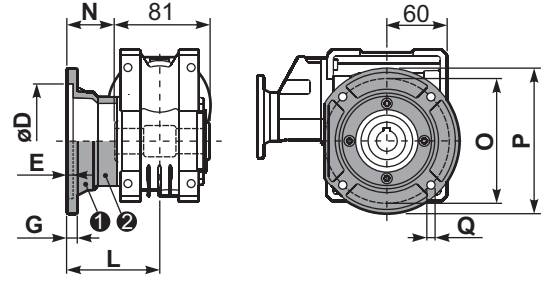

Tip S	øD	E	G	L	N	O	P	Q	Kit Kodu
F1	110 H8	5	10	89	69.5	130	160	9.5	KSQ50.9.012
F2	95 H8	5	14.5	72	31.5	115	140	11	KSQ50.9.013

PP5QFB... Ayak
Feet

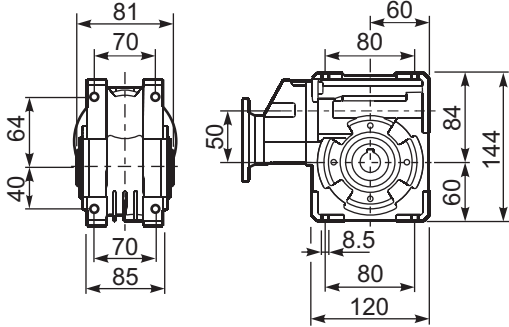

PP5QBR... Tork Kolu
Reaction arm

Kit Kodu KQ50.9.027

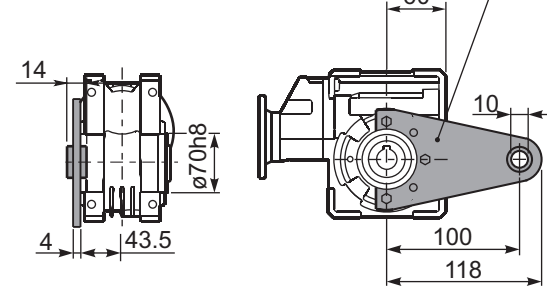

RP5QFB... Giriş Milini
Input shaft

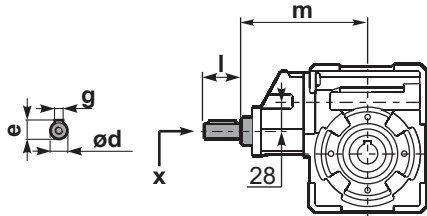

Tip B	ød	e	g	l	m	x
Tip B	14 h6	16	5	25	140.5	M5x13
Tip S	-	-	-	-	-	-

PP5Q.....S... Tek Çıkış Milini
Single Shaft

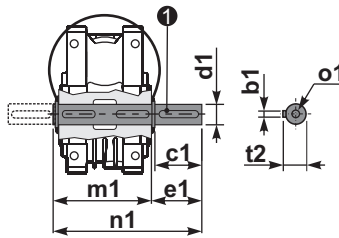

1 Kit Kodu K050.5.028 Tip B
Kit Kodu KS050.5.030 Tip S

PP5Q.....D... Çift Çıkış Milini
Double Shaft

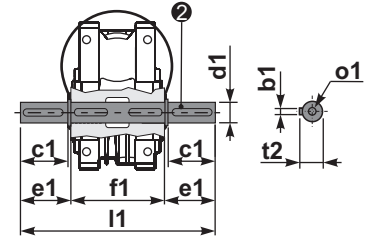

2 Kit Kodu K050.5.029 Tip B
Kit Kodu KS050.5.031 Tip S

Tip B	b1	c1	d1	e1	f1	l1	m1	n1	t2	o1
Tip B	8	52	25 ^{-0.005} _{-0.020}	59.5	81	200	86.5	146	28	M8x20
Tip S	8	50	24 ^{-0.005} _{-0.020}	68.8	81	218	86.5	155	27	M8x20



HIZLI SEÇİM / Quick Selection

Giriş Devri (n_1) = 1400 d/d

Çıkış devri n_2 [d/d]	Tahvil i	Motor gücü P_{1M} [kW]	Çıkış Momenti M_{2M} [Nm]	Servis Faktörü f.s.	Nominal güç P_{1R} [kW]	Nominal moment M_{2R} [Nm]	Uygun B5 motor Flanşları				Uygun B14 motor flanşları				Dinamik verim RD	Modül [mm]	Tahvil kodu
							-B	-C	-D	-E	-P	-Q	-R	-T			
							63	71	80	90	63	71	80	90			
IEC 90 - 80 - 71	47	29.9	0.75	113	1.5	1.1	165					C	C		74	2.6	01
	37	37.7	0.75	141	1.2	0.88	165					C	C		73	2.0	02
	30	47.1	0.75	169	1.1	0.83	187					C	C		70	3.2	03
	25	56.6	0.55	136	1.4	0.76	187					C	C		64	2.7	04
	19.8	70.7	0.55	164	1.1	0.63	187					C	C		62	2.1	05
	15.9	87.8	0.37	162	1.2	0.43	187					C	C		73	2.6	06
	12.6	111.0	0.37	199	0.9	0.35	187					C	C		71	2.0	07
IEC 71 - 63	10.1	139	0.37	234	0.8	0.30	187					C			67	3.2	08
	8.4	166	0.25	173	1.1	0.27	187					C			61	2.7	09
	6.7	208	0.18	151	1.1	0.20	165					C			59	2.1	10
	4.5	310	0.12	129	1.3	0.15	165					C			51	1.5	11
	3.8	370	0.12	145	1.1	0.14	165					C			48	1.3	12
	3.2	434	0.12	149	0.9	0.11	138					C			42	1.1	13

Uygun Motor Flanşları
Motor Flanges Available

B) Burç ile montaj yapılabilir
Supplied with Reduction Bushing

B) Burç Kullanılmadan Montajı Yapılabilir
Available on Request without Reduction Bushing

C) Terminal Kutusu flanş pozisyonu
Motor Flange Holes Position

TR P6Q gövde sonsuz vidalı redüktörler ömürlük sentetik yağ ile yağlanmıştır. V5-V6 montaj pozisyonları için teknik ofisimiz ile iletişime geçiniz. Tablo 1'de uygun yağ seçenekleri ve yağlama miktarları tanımlanmıştır. Tablo 2'de izin verilebilir radyal ve eksenel yükler tanımlanmıştır.

EN Unit P6Q is supplied with synthetic oil, providing "long life" lubrication. For mounting position V5-V6 please contact us. See table 1 for lubrication and recommended quantity. In table 2 please see possible radial loads and axial loads on the gearbox.

YAĞLAMA / LUBRICATION

B3-V5-V6 montaj pozisyonlarında ayrı yağlama A (0.30 lt) B (0.08 l) , B6-B7-B8 montaj pozisyonlarında ortak yağlama 0.35 lt (A + B).

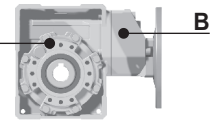

AGIP Telium VSF 320

SHELL Omala S4 WE 320

Daha fazla ayrıntı için internet sitemizi inceleyiniz.

Tablo 1

For all details on lubrication and plugs check our website

RADYAL VE EKSENEL YÜKLER / RADIAL AND AXIAL LOADS

Çıkış Mili

Output Shaft

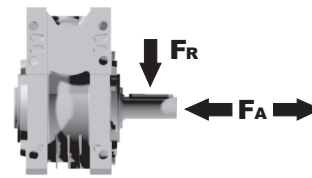

n_2 [d/d]	FA [N]	FR [N]
75	500	2500
50	600	3000
25	700	3800
15-6	800	4000

Giriş Mili

Input Shaft

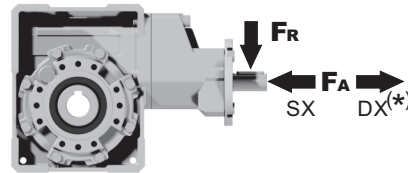

n_1 [d/d]	FA [N]	FR [N]
1400	61	305

*DX yönünde eksenel yüke izin verilmez

Strong axial loads in the DX direction are not allowed.

Tablo 2

PP6QFB... Standart Redüktör
Basic wormbox

Ağırlık Gearbox weight	29.9+111 7.05 Kg	139+434 6.60 Kg
------------------------------	------------------------	-----------------------

M. Flanşlar	Kit Kodu	øF	A
71B5	K063.4.042	160	176.5
80/90B5	K063.4.043	200	178.5
71B14	K063.4.047	105	176.5
80B14	K063.4.046	120	178.5
90B14	K063.4.041	140	178.5
29.9+111			
63B5	K050.4.041	138	162.5
71B5	K050.4.042	160	160
63B14	K050.4.047	90	162.5
71B14	K050.4.045	105	160
139+434			

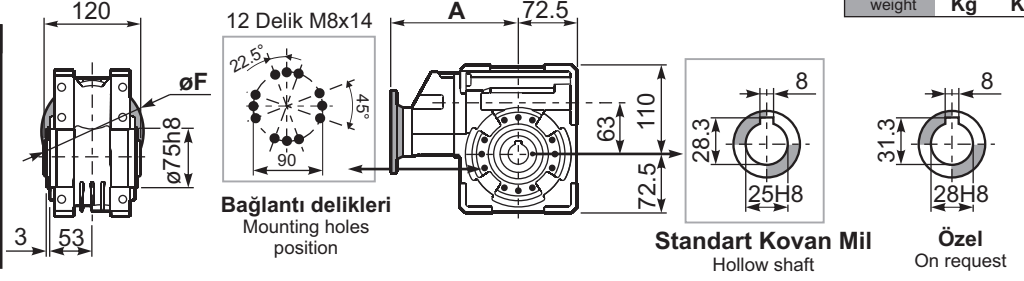

PP6QFC... Kare Çıkış Flanşı
Square flange

PP6QF1... Yuvarlak Çıkış Flanşı
Round flange

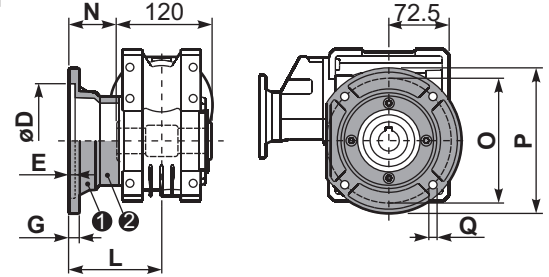
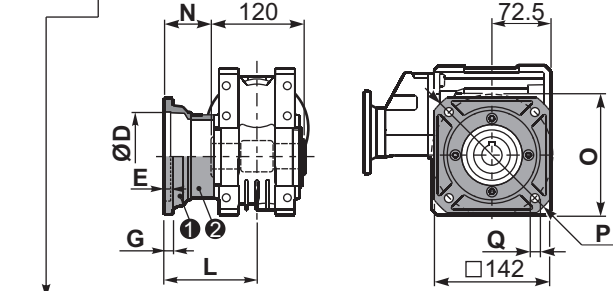

Tip B	øD	E	G	L	N	O	P	Q	Kit Kodu
FC	115 ^{+0.20} / _{+0.15}	6	12	86	26	150	180	11	1 KQ63.9.010 2 -
FL	115 ^{+0.20} / _{+0.15}	6	12	116	56	150	180	11	1 KQ63.9.010 2 K063.0.200

Tip S	øD	E	G	L	N	O	P	Q	Kit Kodu
F1	130 ^{+0.20} / _{+0.15}	7	13	110	50	165	200	13	1 KS070.9.013 2 -
F2	115 ^{+0.20} / _{+0.15}	7	13	124	64	150	175	11	1 KS063.9.013 2 -
F3	110 ^{+0.035} / ₀	5	11	90	30	130	160	10	1 KS063.9.011 2 -

PP6QFB... Ayak
Feet

PP6QBR... Tork Kolu
Reaction arm

Kit Kodu K063.9.027

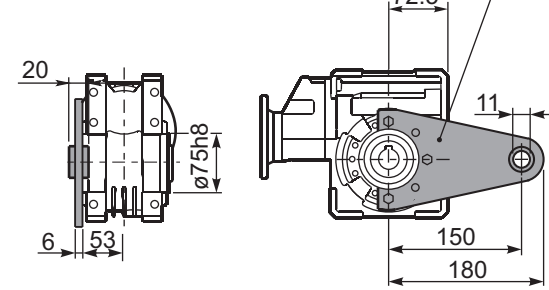
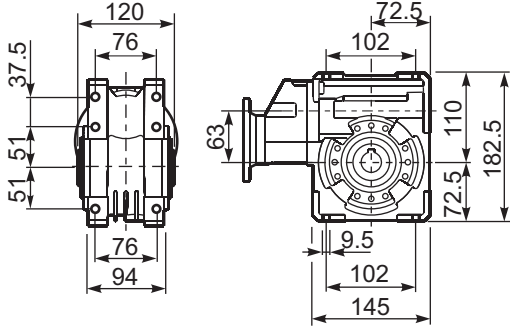

RP6QFB... Giriş Milini
Input shaft

PP6Q.....S... Tek Çıkış Milini
Single Shaft

PP6Q.....D... Çift Çıkış Milini
Double Shaft

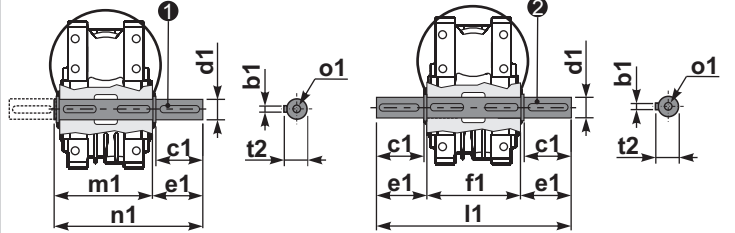
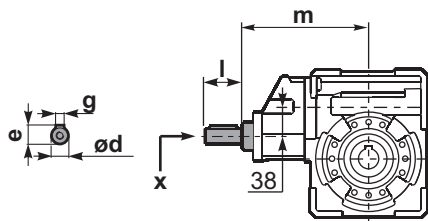

1 Kit Kodu K063.5.028 Tip B

2 Kit Kodu K063.5.029 Tip B

	ød	e	g	l	m	x	
29.9+111	19 h6	21.5	6	35	169.4	M6x16	C40.5.062
139+434	14 h6	16	5	25	154.2	M5x13	C35.5.061

	b1	c1	d1	e1	f1	l1	m1	n1	t2	o1
Tip B	8	60	25 ^{-0.005} / _{-0.020}	63.2	120	246.4	126.8	190	28	M8x20
Tip S	-	-	-	-	-	-	-	-	-	-

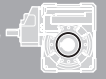

HIZLI SEÇİM / Quick Selection

Giriş Devri (n₁) = 1400 d/d

Çıkış devri n ₂ [d/d]	Tahvil i	Motor gücü P _{1M} [kW]	Çıkış Momenti M _{2M} [Nm]	Servis Faktörü f.s.	Nominal güç P _{1R} [kW]	Nominal moment M _{2R} [Nm]	Uygun B5 motor Flanşları				Uygun B14 motor flanşları			Dinamik verim RD	Modül [mm]	Tahvil kodu
							-B	-C	-D	-E	-Q	-R	-T			
							63	71	80	90	71	80	90			
22	62.9	0.75	248	1.2	0.87	286					C	C		77	3.10	01
18	78.5	0.75	293	1.0	0.73	286					C	C		73	2.41	02
15	94.2	0.75	333	0.9	0.70	310					C	C		69	2.10	03
11	126	0.55	297	1.0	0.55	296	B				C	C		63	1.53	04
9	157	0.37	230	1.1	0.41	252	B				C	C		58	1.23	05
8	185	0.37	257	1.2	0.43	296	B				C	C		55	3.10	06
6	231	0.25	193	1.5	0.38	296	B				C	C		49	2.41	07
5	277	0.25	222	1.3	0.33	296	B				C	C		47	2.10	08
4	378	0.18	200	1.5	0.27	296	B				C	C		43	2.10	09

Uygun Motor Flanşları
Motor Flanges Available

B) Burç ile montaj yapılabilir
Supplied with Reduction Bushing

B) Burç Kullanılmadan Montajı Yapılabilir
Available on Request without Reduction Bushing

C) Teminal Kutusu flanş pozisyonu
Motor Flange Holes Position

* Tablolarda verilen değerlerin üzerindeki motor güçleri için seçimleri M_{2R} değerini referans alarak yapınız.
Power higher than the maximum one which can be supported by the gearbox. Select according to the torque M_{2R}

TR P7Q gövde sonsuz vidalı redüktörler ömürlük sentetik yağ ile yağlanmıştır. V5-V6 montaj pozisyonları için teknik ofisimiz ile iletişime geçiniz. Tablo 1'de uygun yağ seçenekleri ve yağlama miktarları tanımlanmıştır. Tablo 2'de izin verilebilir radyal ve eksenel yükler tanımlanmıştır.

EN Unit P7Q is supplied with synthetic oil, providing "long life" lubrication. For mounting position V5-V6 please contact us. See table 1 for lubrication and recommended quantity. In table 2 please see possible radial loads and axial loads on the gearbox.

YAĞLAMA / LUBRICATION

B3-V5-V6 montaj pozisyonlarında ayrı yağlama A (0.40 lt) B (0.14 lt) , B6-B7-B8 montaj pozisyonlarında ortak yağlama 0.65 lt (A + B).

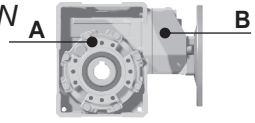

AGIP Telium VSF 320

SHELL Omala S4 WE 320

Daha fazla ayrıntı için internet sitemizi inceleyiniz.
For all details on lubrication and plugs check our website

Tablo 1

RADYAL VE EKSENEL YÜKLER / RADIAL AND AXIAL LOADS

Çıkış Mili Output Shaft

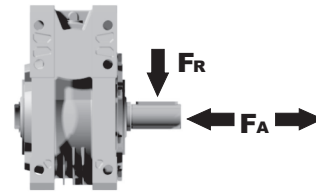

n ₂ [d/d]	FA [N]	FR [N]
75	620	3100
50	720	3600
25	880	4400
15-6	1000	5000

Giriş Mili Input Shaft

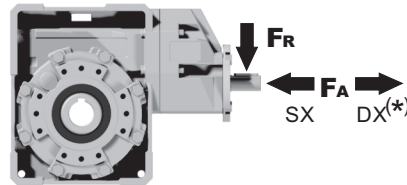

n [d/d]	FA [N]	FR [N]
1400	108	540

*DX yönünde eksenel yüke izin verilmez
Strong axial loads in the DX direction are not allowed.

Tablo 2

PP7QFB... Standart Redüktör
Basic wormbox

Ağırlık
Gearbox
weight **9.90 kg**

M. Flanşlar	Kit Kodu	øF	A
63B5	K063.4.041	140	192.7
71B5	K063.4.042	160	190.7
80/90B5	K063.4.043	200	192.7
71B14	K063.4.047	105	190.7
80B14	K063.4.046	120	192.7
90B14	K063.4.041	140	192.7

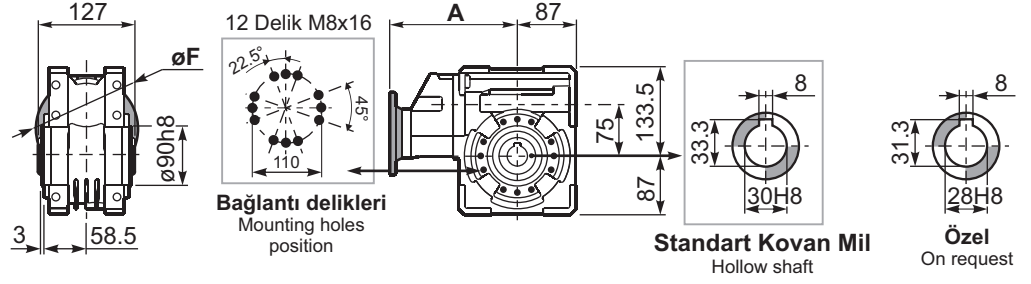

PP7QFC... Kare Çıkış Flanşı
Square flange

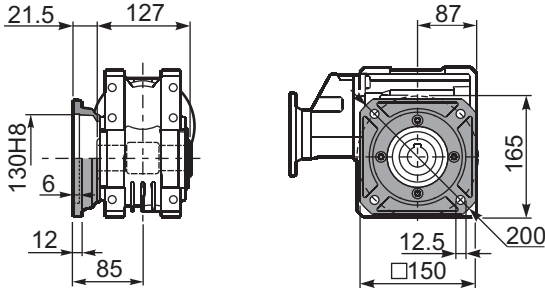

PP7QFL... Yuvarlak Çıkış Flanşı
Round flange

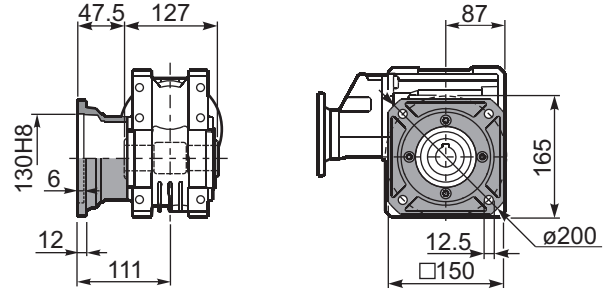

PP7QFB... Ayak
Feet

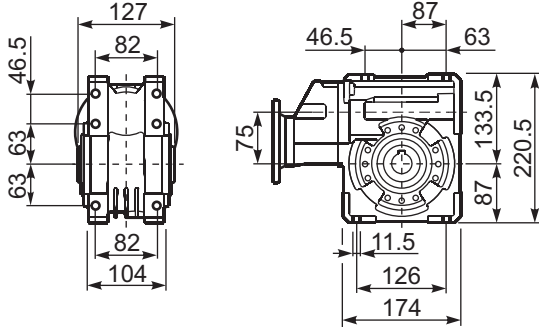

PP7QBR... Tork Kolu
Reaction arm

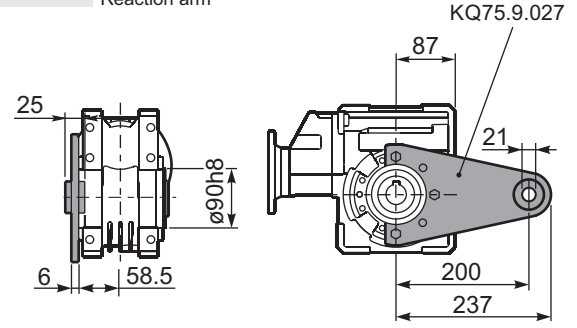

RP7QFB... Giriş Mili
Input shaft

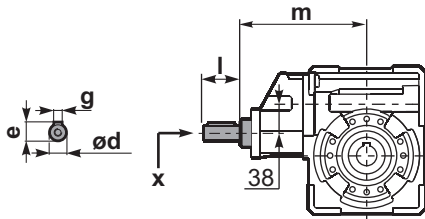

PP7Q.....S... Tek Çıkış Mili
Single Shaft

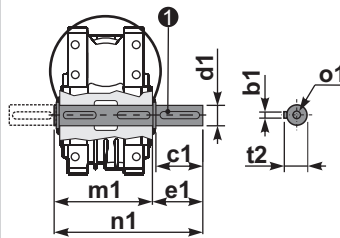

PP7Q.....D... Çift Çıkış Mili
Double Shaft

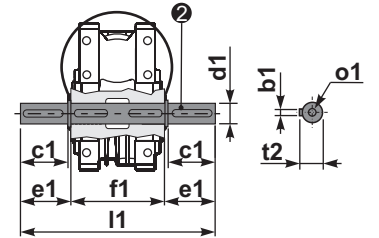

① Kit Kodu KQ75.5.028 Standart
Kit Kodu KQ75.5.026 Özel

② Kit Kodu KQ75.5.029 Standart
Kit Kodu KQ75.5.027 Özel

	ød	e	g	l	m	x	
Tip B	19 h6	21.5	6	35	185.5	M6x16	C40.5.062
Tip S	-	-	-	-	-	-	

	b1	c1	d1	e1	f1	l1	m1	n1	t2	o1
Standart	8	60	30 ^{-0.005/-0.020}	65	127	255	134	199	33	M8x20
Özel	8	50	28 ^{-0.005/-0.020}	65	127	255	134	199	31	M8x20



HIZLI SEÇİM / Quick Selection

Giriş Devri (n₁) = 1400 d/d

Çıkış devri n ₂ [d/d]	Tahvil i	Motor gücü P _{1M} [kW]	Çıkış Momenti M _{2M} [Nm]	Servis Faktörü f.s.	Nominal güç P _{1R} [kW]	Nominal moment M _{2R} [Nm]	Uygun B5 motor Flanşları				Uygun B14 motor flanşları			Dinamik verim RD	Modül [mm]	Tahvil kodu
							-B	-C	-D	-E	-Q	-R	-T			
							63	71	80	90	71	80	90			
23.5	59.7	1.1	300	1.4	1.5	418					C	C		67	3.5	01
19.4	72.3	1.1	347	1.2	1.3	407					C	C		64	3.1	02
17.1	81.7	1.1	374	1.1	1.2	418					C	C		61	2.7	03
13.3	105	0.75	323	1.2	0.89	385					C	C		60	2.1	04
8.0	176	0.55	415	1.1	0.58	440	B				C	C		63	3.5	05
6.6	213	0.37	322	1.3	0.47	407	B				C	C		60	3.1	06
5.8	240	0.37	321	1.3	0.48	418	B				C	C		53	2.7	07
4.3	328	0.37	438	1.0	0.35	418	B				C	C		53	2.7	08
3.3	422	0.25	374	1.0	0.26	385	B				C	C		52	2.1	09
3.0	466	0.25	358	0.9	0.23	330	B				C	C		45	1.9	10
2.3	605	0.18	297	1.1	0.20	330	B				C	C		40	1.5	11

Uygun Motor Flanşları
Motor Flanges Available

B) Burç ile montaj yapılabilir
Supplied with Reduction Bushing

B) Burç Kullanılmadan Montajı Yapılabilir
Available on Request without Reduction Bushing

C) Teminal Kutusu flanş pozisyonu
Motor Flange Holes Position

TR P8Q gövde sonsuz vidalı redüktörler ömürlük sentetik yağ ile yağlanmıştır. V5-V6 montaj pozisyonları için teknik ofisimiz ile iletişime geçiniz.

Tablo 1'de uygun yağ seçenekleri ve yağlama miktarları tanımlanmıştır.

Tablo 2'de izin verilebilir radyal ve aksel yükler tanımlanmıştır.

EN Unit P8Q is supplied with synthetic oil, providing "long life" lubrication. For mounting position V5-V6 please contact us. See table 1 for lubrication and recommended quantity. In table 2 please see possible radial loads and axial loads on the gearbox.

YAĞLAMA / LUBRICATION

B3-V5-V6 montaj pozisyonlarında ayrı yağlama A (1.20 lt) B (0.14 lt) , B6-B7-B8 montaj pozisyonlarında ortak yağlama 1.00 lt (A + B).

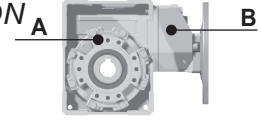

AGIP Telium VSF 320

SHELL Omala S4 WE 320

Daha fazla ayrıntı için internet sitemizi inceleyiniz.
For all details on lubrication and plugs check our website

Tablo 1

RADYAL VE EKSENEL YÜKLER / RADIAL AND AXIAL LOADS

Çıkış Mili Output Shaft

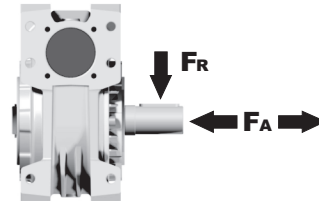

n ₂ [d/d]	FA [N]	FR [N]
75	700	3500
50	800	4000
25	1000	5000
15-6	1160	5800

Giriş Mili Input Shaft

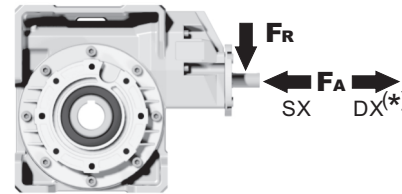

n ₁ [d/d]	FA [N]	FR [N]
1400	108	540

*DX yönünde aksel yükü izin verilmez.
Strong axial loads in the DX direction are not allowed.

Tablo 2

PP8QFB... Standart Redüktör
Basic wormbox

Ağırlık
Gearbox
weight **12.3 kg**

M. Flanşlar	Kit Kodu	øF	A
63B5	K063.4.041	140	195.2
71B5	K063.4.042	160	193.2
80/90B5	K063.4.043	200	195.2
71B14	K063.4.047	105	193.2
80B14	K063.4.046	120	195.2
90B14	K063.4.041	140	195.2

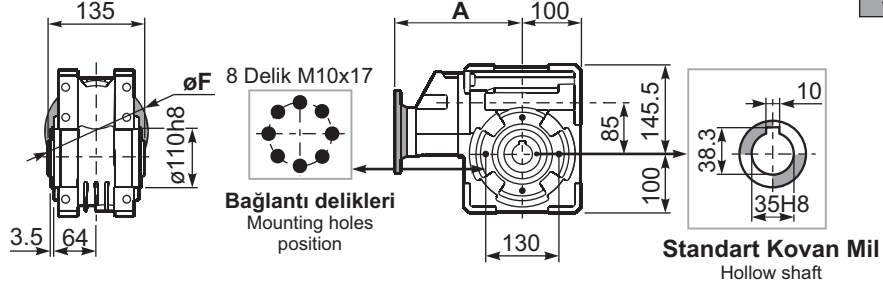

PP8QFC... Çıkış Flanşı
Output flange

PP8QF1... Çıkış Flanşı
Output flange

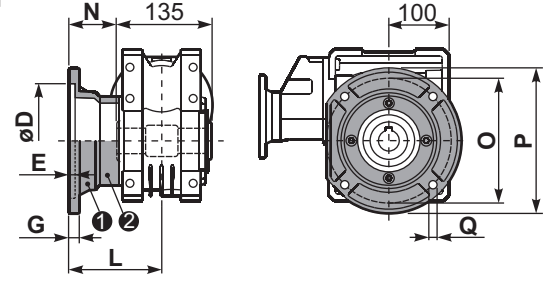
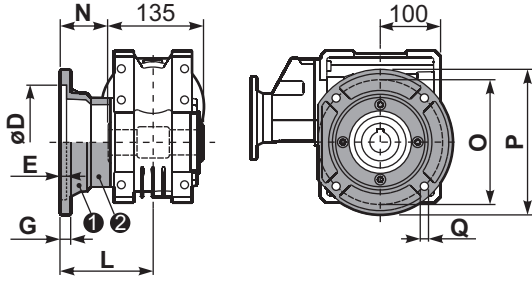

Tip B	øD	E	G	L	N	O	P	Q	Kit Kodu
FC	152 ^{+0.06} / _{+0.00}	5	16	108	40.5	176	205	13	1 K085.9.010 2 -
FL	152 ^{+0.06} / _{+0.00}	5	16	148.5	81	176	205	13	1 K085.9.010 2 K085.0.201

Tip S	øD	E	G	L	N	O	P	Q	Kit Kodu
F1	130 ^{+0.04} / _{+0.00}	5	13	117.5	50	165	200	11.5	1 KS085.9.012 2 -
F2	152 ^{+0.06} / _{+0.00}	5	15	147.5	80	180	205	12.5	1 KS085.9.013 2 -
F4	130 ^{+0.04} / _{+0.00}	5	13	106.5	39	165	200	13	1 KS085.9.015 2 -

PP8QFB... Ayak
Feet

PP8QBR... Tork Kolu
Reaction arm

Kit Kodu K085.9.027

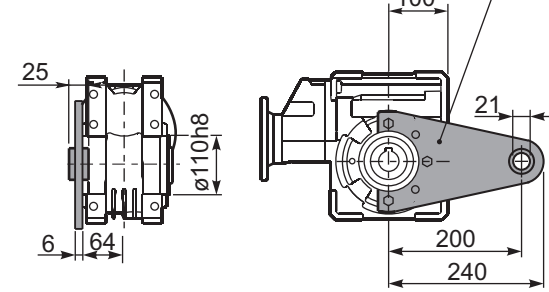
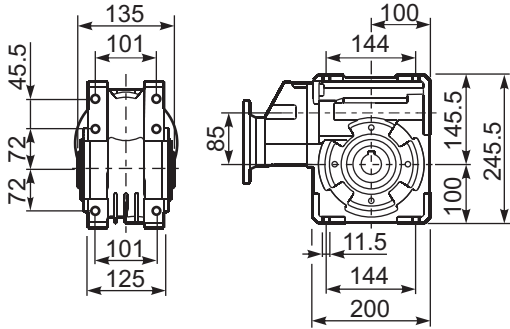

RPP8QFB... Giriş Mili
Input shaft

PP8Q.....S... Tek Çıkış Mili
Single Shaft

PP8Q.....D... Çift Çıkış Mili
Double Shaft

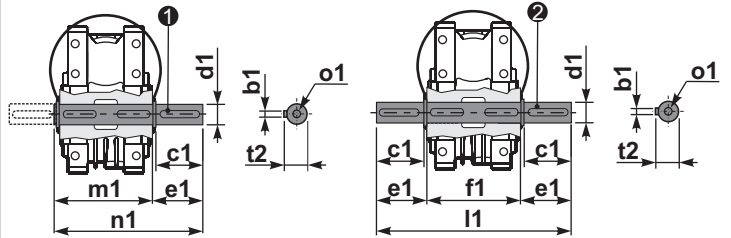
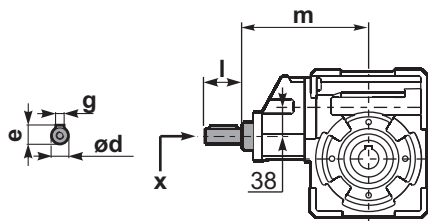

1 Kit Kodu K085.5.028 Tip B

2 Kit Kodu K085.5.029 Tip B

Tip B	ød	e	g	l	m	x
Tip B	19 h6	21.5	6	35	187.5	M6x16
Tip S	-	-	-	-	-	-

Tip B	b1	c1	d1	e1	f1	l1	m1	n1	t2	o1
Tip B	10	60	35 ^{-0.005} / _{-0.020}	73.5	135	282	141	214.5	38	M10x23
Tip S	-	-	-	-	-	-	-	-	-	-



HIZLI SEÇİM / Quick Selection

Giriş Devri (n₁) = 1400 d/d

Çıkış devri n ₂ [d/d]	Tahvil i	Motor gücü P _{1M} [kW]	Çıkış Momenti M _{2M} [Nm]	Servis Faktörü f.s.	Nominal güç P _{1R} [kW]	Nominal moment M _{2R} [Nm]	Uygun B5 motor Flaşları				Uygun B14 motor flaşları			Dinamik verim RD	Modül [mm]	Tahvil kodu
							-B	-C	-D	-E	-Q	-R	-T			
							63	71	80	90	71	80	90			
16.8	83.2	1.5	587	1.1	1.7	660					C			69	3.5	01
13.9	100.5	1.5	699	0.8	1.3	594					C			68	2.9	02
10.6	132	1.1	634	0.9	0.95	550					C			64	2.2	03
8.0	176	0.75	666	1.2	0.90	803	B				C			74	4.7	04
6.7	208	0.75	766	0.9	0.65	660	B				C			72	4.0	05
5.7	245	0.55	634	1.0	0.57	660	B				C			69	3.5	06
4.7	296	0.55	755	0.8	0.43	594	B				C			68	2.9	07
4.2	334	0.55	865	0.8	0.42	660	B				C			69	3.5	08
3.5	403	0.37	692	0.9	0.32	594	B				C			68	2.9	09
2.6	529	0.25	577	1.0	0.24	550	B				C			64	2.2	10
2.2	624	0.25	628	0.8	0.21	528	B				C			59	1.9	11

Uygun Motor Flaşları
Motor Flanges Available

B) Burç ile montaj yapılabilir
Supplied with Reduction Bushing

B) Burç Kullanılmadan Montajı Yapılabilir
Available on Request without Reduction Bushing

C) Teminal Kutusu flaş pozisyonu
Motor Flange Holes Position

TR P1Q gövde redüktörler yağsız olarak sevk edilir. Redüktör üzerinde havalandırma tapası, yağ göstergesi ve tahliye tapası mevcuttur. Mineral yağlar bu ekipmanlar ile birlikte kullanılır. Sentetik yağ kullanılmak istenirse bu ekipmanların körtapa ile değiştirilmesi önerilir. Tablo 1'de montaj pozisyonuna göre uygun yağ miktarları tanımlanmıştır. Tablo 2'de izin verilebilir radyal ve eksenel yük değerleri tanımlanmıştır.

EN Unit P1Q is supplied without lubricant and equipped with a breather, level and drain plugs. User can add mineral oil keeping existing plugs. Should the user wish to fill it with synthetic oil, it is recommended to replace the existing plugs with a closed plug. Primary reduction unit is supplied with closed plugs and lubricated for life with synthetic oil. See table 1 for lubrication and recommended quantity. In table 2 please see possible radial loads and axial loads on the gearbox.

B3	B6	B7	B8	V5	V6
2.0/0.14LT	1.35/0.14 LT	1.35/0.14 LT	2.0/0.14 LT	2.0/0.14 LT	2.0/0.14 LT

AGIP Blasias 460

Daha fazla ayrıntı için internet sitemizi inceleyiniz.
For all details on lubrication and plugs check our website

Tablo 1

RADYAL VE EKSENEL YÜKLER / RADIAL AND AXIAL LOADS

Çıkış Mili
Output Shaft

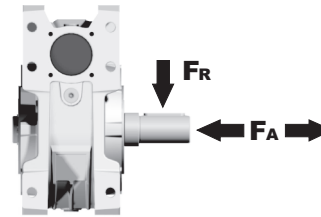

n ₂ [d/d]	FA [N]	FR [N]
75	800	4000
50	920	4600
25	1200	6000
15-6	1400	7000

Giriş Mili
Input Shaft

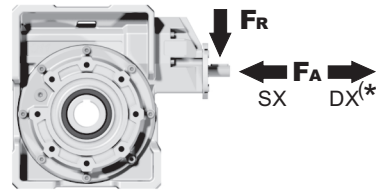

n ₁ [d/d]	FA [N]	FR [N]
1400	150	760

*DX yönünde eksenel yüke izin verilmez
Strong axial loads in the DX direction are not allowed.

Tablo 2

PP1QFB... Standart Redüktör
Basic wormbox

Ağırlık
Gearbox
weight **37.3 kg**

M. Flanşlar	Kit Kodu	øF	A
63B5	K063.4.041	140	214.7
71B5	K063.4.042	160	212.7
80/90B5	K063.4.043	200	214.7
71B14	K063.4.047	105	212.7
80B14	K063.4.046	120	214.7
90B14	K063.4.041	140	214.7

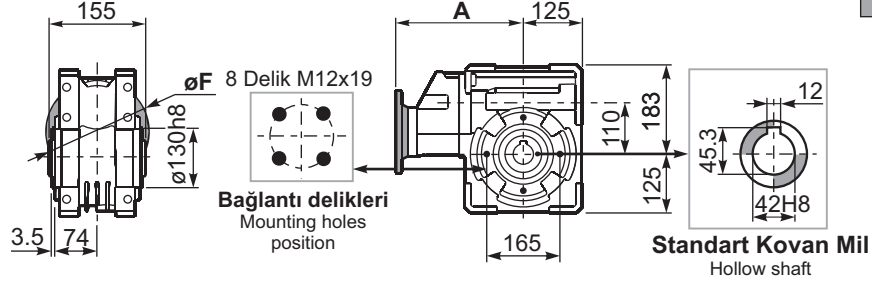

2

PP1QFC... Kare Çıkış Flanşı
Square flange

PP1QF1... Yuvarlak Çıkış Flanşı
Round flange

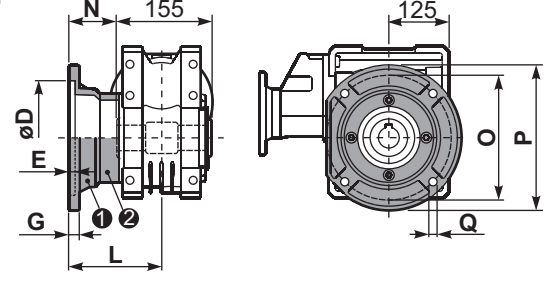
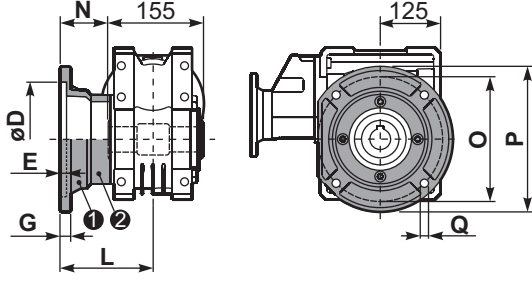

Tip B	øD	E	G	L	N	O	P	Q	Kit Kodu
FC	170 ^{+0.083} _{+0.043}	11	16.5	131.5	54	230	270	13	1 K110.9.010 2 -
FL	170 ^{+0.083} _{+0.043}	11	16.5	179.5	102	230	270	13	1 K110.9.011 2 -

Tip S	øD	E	G	L	N	O	P	Q	Kit Kodu
F1	180 ^{+0.040} ₀	5	18	150	72.5	215	250	15	1 KS110.9.014 2 -
F2	170 ^{+0.083} _{+0.043}	9.5	15	178	100.5	230	270	13	1 KS110.9.012 2 -
F3	180 ^{+0.040} ₀	5	18	130	52.5	215	250	15	1 KS110.9.013 2 -

PP1QFB... Ayak
Feet

PP1QBR... Tork Kolu
Reaction arm

Kit Kodu K110.9.027

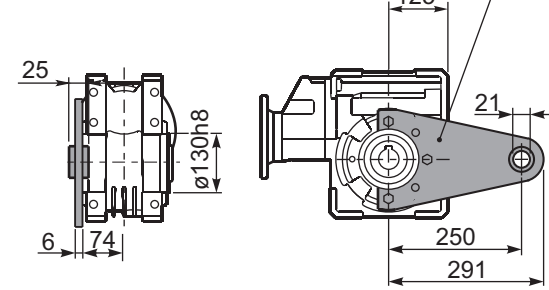
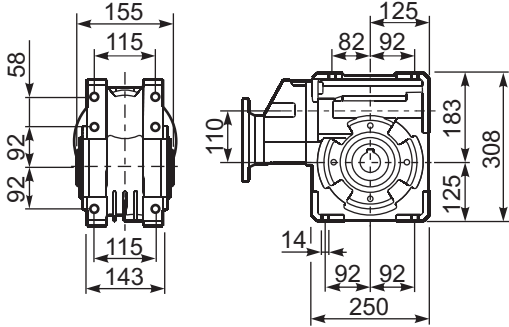

RP1QFB... Giriş Mili
Input shaft

PP1Q.....S... Tek Çıkış Mili
Single Shaft

PP1Q.....D... Çift Çıkış Mili
Double Shaft

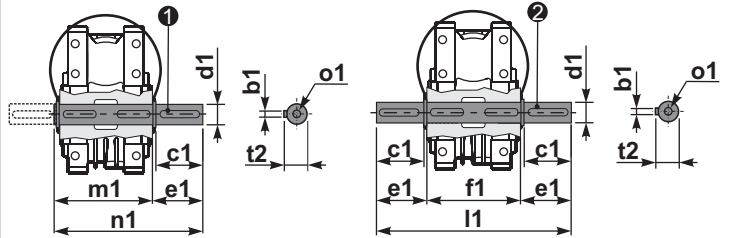
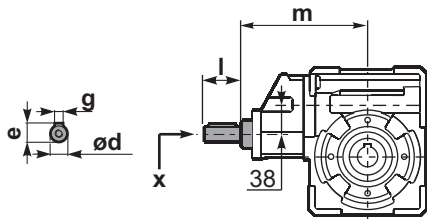

1 Kit Kodu K110.5.028 Tip B

2 Kit Kodu K110.5.029 Tip B

Tip B	ød	e	g	l	m	x
Tip B	19 h6	21.5	6	35	205	M6x16
Tip S	-	-	-	-	-	-

Tip B	b1	c1	d1	e1	f1	l1	m1	n1	t2	o1
Tip B	12	75	42 ^{-0.005} _{-0.020}	96.5	155	348	163.5	260	45	M12x32
Tip S	-	-	-	-	-	-	-	-	-	-

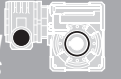

HIZLI SEÇİM / Quick Selection

Giriş Devri (n_1) = 1400 d/d

Çıkış devri n_2 [d/d]	Tahvil i	Motor gücü P_{1M} [kW]	Çıkış Momenti M_{2M} [Nm]	Servis Faktörü f.s.	Nominal güç P_{1R} [kW]	Nominal moment M_{2R} [Nm]	Uygun B5 motor Flanşları		Uygun B14 motor flanşları		Dinamik verim RD	Modül [mm]	Tahvil kodu
							-A	-B	-O	-P			
							56	63	56	63			
10.0	140	0.12	57	1.2	0.14	69	B		B-C		50	2.2	01
7.0	200	0.12	79	0.9	0.11	69	B		B-C		48	2.2	02
5.0	280	0.12*	69	<0.8	0.08	69	B		B-C		45	2.4	03
3.3	420	0.12*	69	<0.8	0.07	69	B		B-C		36	1.6	04
2.5	560	0.12*	69	<0.8	0.05	69	B		B-C		33	2.5	05
1.9	740	0.12*	69	<0.8	0.05	69	B		B-C		30	1.8	06
1.5	920	0.12*	69	<0.8	0.04	69	B		B-C		27	1.5	07
1.3	1120	0.12*	69	<0.8	0.03	69	B		B-C		26	2.5	08
0.9	1480	0.12*	69	<0.8	0.03	69	B		B-C		24	1.8	09
0.8	1840	0.12*	69	<0.8	0.02	69	B		B-C		22	1.5	10
0.6	2400	0.12*	69	<0.8	0.02	69	B		B-C		21	1.2	11

Uygun Motor Flanşları
Motor Flanges Available

B) Burç ile montaj yapılabilir
Supplied with Reduction Bushing

B) Burç Kullanılmadan Montajı Yapılabilir
Available on Request without Reduction Bushing

C) Teminal Kutusu flanş pozisyonu
Motor Flange Holes Position

* Tablolarda verilen değerlerin üzerindeki motor güçleri için seçimleri M_{2R} değerini referans alarak yapınız.
Power higher than the maximum one which can be supported by the gearbox. Select according to the torque M_{2R}

TR 43Q gövde sonsuz vidalı redüktörler ömürlük sentetik yağ ile yağlanmıştır. V5-V6 montaj pozisyonları için teknik ofisimiz ile iletişime geçiniz. Tablo 1'de uygun yağ seçenekleri ve yağlama miktarları tanımlanmıştır. Tablo 2'de izin verilebilir radyal ve aksel yükler tanımlanmıştır.

EN Unit 43Q is supplied with synthetic oil, providing "long life" lubrication. For mounting position V5-V6 please contact us. See table 1 for lubrication and recommended quantity. In table 2 please see possible radial loads and axial loads on the gearbox.

YAĞLAMA

0.09 Lt.

Yağ Miktarı 0.09/0.03 Lt.

LUBRICATON
Oil Quantity 0.09/0.03 Lt.

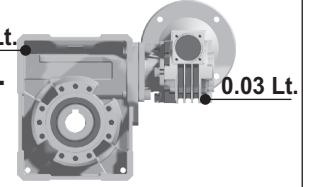

AGIP Telium VSF 320

SHELL Omala S4 WE 320

Daha fazla ayrıntı için internet sitemizi inceleyiniz.

For all details on lubrication and plugs check our website

Tablo 1

RADYAL VE EKSESEL YÜKLER / RADIAL AND AXIAL LOADS

Çıkış Mili

Output Shaft

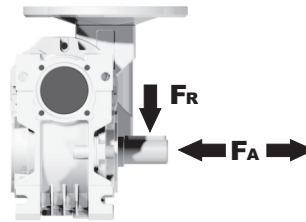

n_2 [d/d]	F_A [N]	F_R [N]
25	300	1800
15	400	2000

Giriş Mili

Input Shaft

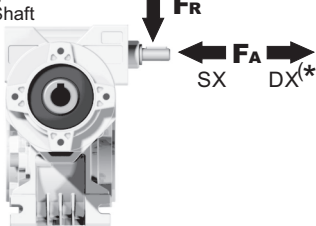

n_1 [d/d]	F_A [N]	F_R [N]
1400	20	100

*DX yönünde aksel yüke izin verilmez.

Strong axial loads in the DX direction are not allowed.

Tablo 2

P43Q**FB**... Standart Redüktör
Basic wormbox

M. Flanşları	Kit Kodu	øF	A
56B5	K030.4.041	120	61.5
63B5	K030.4.042	140	62.5
56B14	K030.4.046	80	61.5
63B14	K030.4.045	90	62.5

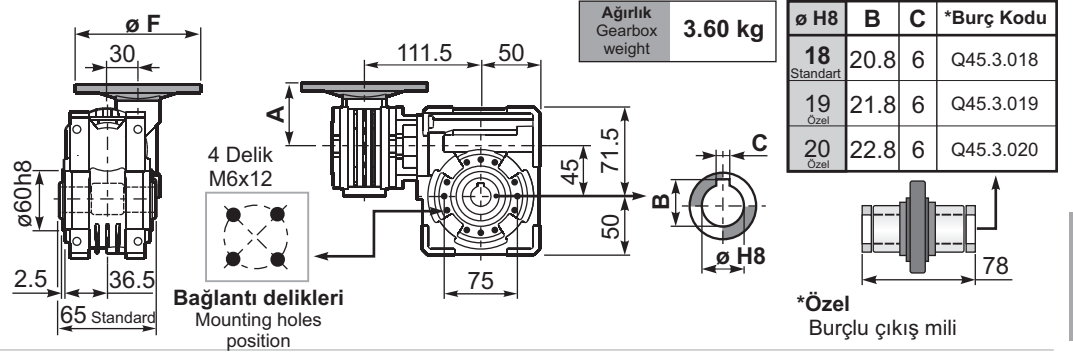

P43Q**FC**... Kare Çıkış Flanşı
Square flange

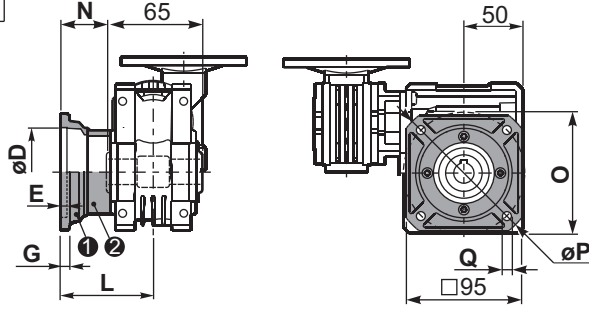

Tip B	øD	E	G	L	N	O	P	Q	Kit Kodu
FC	60 H8	4	7	67	34.5	75	110	9	KQ45.9.010
FL	60 H8	4	7	97	64.5	75	110	9	KQ45.9.011

P43Q**F1**... Yuvarlak Çıkış Flanşı
Round flange

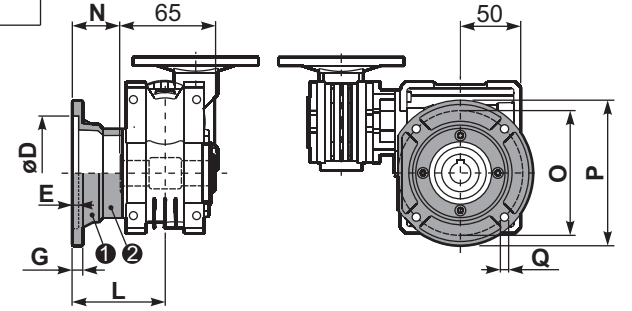

Tip S	øD	E	G	L	N	O	P	Q	Kit Kodu
F1	95H8	5	9	80	47.5	115	140	9.5	KSQ50.9.012
F2	80H8	5	12	58	25.5	100	120	9	KSQ50.9.013

P43Q**FB**... Ayak
Feet

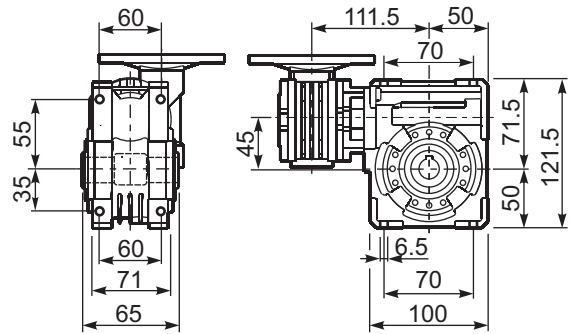

P43Q**BR**... Tork Kolu
Reaction arm

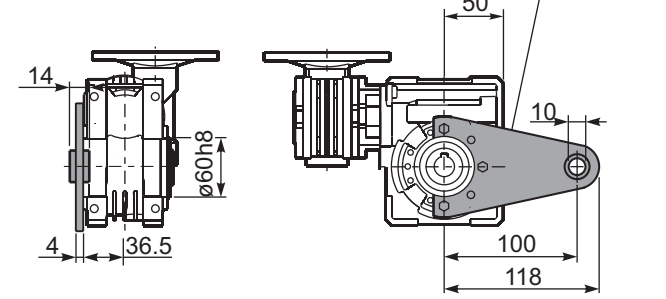

R43Q**FB**... Giriş Mili
Input shaft

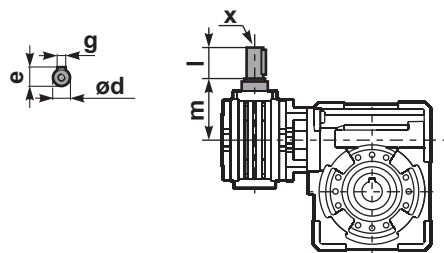

	ød	e	g	l	m	x	Kit Kodu
Tip B	9 h6	10.2	3	20	58	-	K030.5.006 PAM63
Tip S	-	-	-	-	-	-	-

P43Q.....**S**... Tek Çıkış Mili
Single Shaft

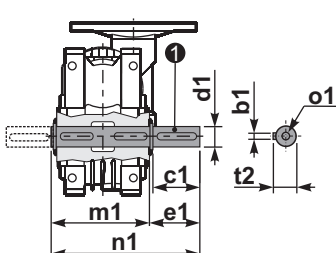

① Kit Kodu K045.5.028 Tip B
Kit Kodu KS045.5.030 Tip S

P43Q.....**D**... Çift Çıkış Mili
Double Shaft

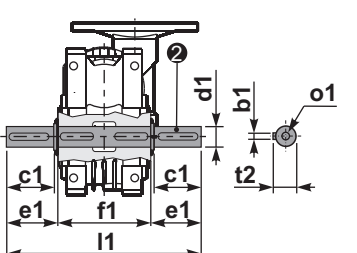

② Kit Kodu K045.5.029 Tip B
Kit Kodu KS045.5.031 Tip S

	b1	c1	d1	e1	f1	l1	m1	n1	t2	o1
Tip B	6	32	18 ^{-0.005} _{-0.020}	43	65	151	70	113	20.5	M6x18
Tip S	6	40	19 ^{-0.005} _{-0.020}	58.5	65	182	70	128.5	21.5	M8x20



HIZLI SEÇİM / Quick Selection

Giriş Devri (n₁) = 1400 d/d

Çıkış devri n ₂ [d/d]	Tahvil i	Motor gücü P _{1M} [kW]	Çıkış Momenti M _{2M} [Nm]	Servis Faktörü f.s.	Nominal güç P _{1R} [kW]	Nominal moment M _{2R} [Nm]	Uygun B5 motor Flanşları		Uygun B14 motor flanşları		Dinamik verim RD	Modül [mm]	Tahvil kodu
							-A	-B	-O	-P			
							56	63	56	63			
5.6	252	0.12	97	1.1	0.14	109	B		B-C		47	2.1	01
3.9	360	0.12	124	0.9	0.11	109	B		B-C		42	2.1	02
2.6	540	0.12*	109	<0.8	0.08	109	B		B-C		39	2.1	03
1.9	720	0.12*	109	<0.8	0.06	109	B		B-C		36	2.1	04
1.6	860	0.12*	109	<0.8	0.06	109	B		B-C		32	1.8	05
1.2	1200	0.12*	109	<0.8	0.05	109	B		B-C		27	1.3	06
1.0	1440	0.12*	109	<0.8	0.04	109	B		B-C		26	2.1	07
0.8	1720	0.12*	109	<0.8	0.04	109	B		B-C		25	1.8	08
0.6	2400	0.12*	104	<0.8	0.03	104	B		B-C		21	1.3	09

Uygun Motor Flanşları
Motor Flanges Available

B) Burç ile montaj yapılabilir
Supplied with Reduction Bushing

B) Burç Kullanılmadan Montajı Yapılabilir
Available on Request without Reduction Bushing

C) Teminal Kutusu flanş pozisyonu
Motor Flange Holes Position

* Tablolarda verilen değerlerin üzerindeki motor güçleri için seçimleri M_{2R} değerini referans alarak yapınız.
Power higher than the maximum one which can be supported by the gearbox. Select according to the torque M_{2R}

TR 53Q gövde sonsuz vidalı redüktörler ömürlük sentetik yağ ile yağlanmıştır. V5-V6 montaj pozisyonları için teknik ofisimiz ile iletişime geçiniz. Tablo 1'de uygun yağ seçenekleri ve yağlama miktarları tanımlanmıştır. Tablo 2'de izin verilebilir radyal ve eksenel yükler tanımlanmıştır.

EN Unit 53Q is supplied with synthetic oil, providing "long life" lubrication. For mounting position V5-V6 please contact us. See table 1 for lubrication and recommended quantity. In table 2 please see possible radial loads and axial loads on the gearbox.

YAĞLAMA

0.14 Lt.

Yağ Miktarı 0.14/0.03 Lt.

LUBRICATON

Oil Quantity 0.14/0.03 Lt.

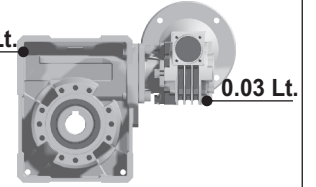

AGIP Telium VSF 320

SHELL Omala S4 WE 320

Daha fazla ayrıntı için internet sitemizi inceleyiniz.
For all details on lubrication and plugs check our website

Tablo 1

RADYAL VE EKSENEL YÜKLER / RADIAL AND AXIAL LOADS

Çıkış Mili
Output Shaft

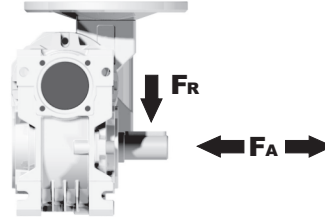

n ₂ [d/d]	FA [N]	FR [N]
25	480	2500
15	560	2800

Giriş Mili
Input Shaft

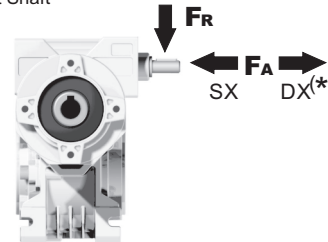

n ₁ [d/d]	FA [N]	FR [N]
1400	20	100

*DX yönünde eksenel yüke izin verilmez
Strong axial loads in the DX direction are not allowed.

Tablo 2

P53Q**FB**... Standart Redüktör
Basic wormbox

M. Flanşları	Kit Kodu	øF	A
56B5	K030.4.041	120	61.5
63B5	K030.4.042	140	62.5
56B14	K030.4.046	80	61.5
63B14	K030.4.045	90	62.5

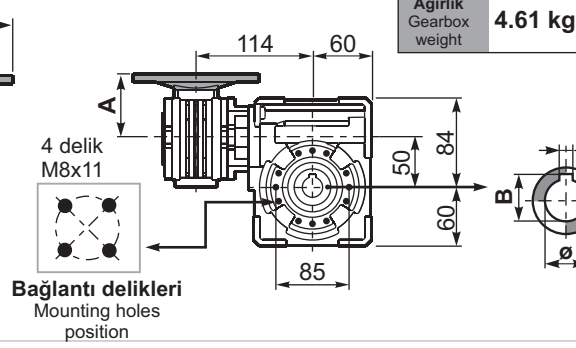
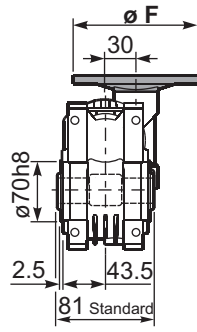

Ağırlık
Gearbox
weight
4.61 kg

ø H8	B	C	*Burç Kodu
25 Standart	28.3	8	Q50.3.025
24 Özel	27.3	8	Q50.3.024

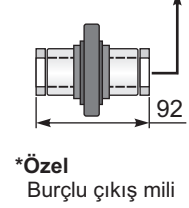

P53Q**FC**... Kare Çıkış Flanşı
Square flange

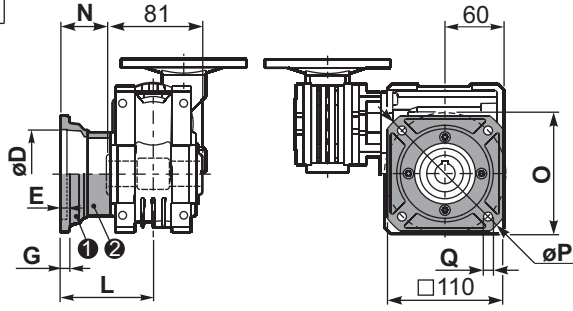

Tip B	øD	E	G	L	N	O	P	Q	Kit Kodu
FC	70 H8	5	9	90	49.5	85	125	11	KQ50.9.010
FL	70 H8	5	9	120	79.5	85	125	11	KQ50.9.011

P53Q**F1**... Yuvarlak Çıkış Flanşı
Round flange

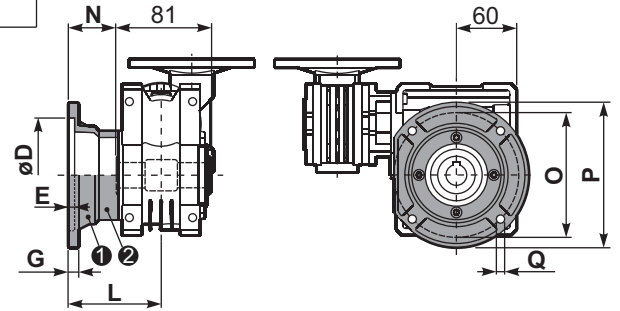

Tip S	øD	E	G	L	N	O	P	Q	Kit Kodu
F1	110 H8	5	10	89	48.5	130	160	9.5	KSQ50.9.012
F2	95 H8	5	14.5	72	31.5	115	140	11	KSQ50.9.013

P53Q**FB**... Ayak
Feet

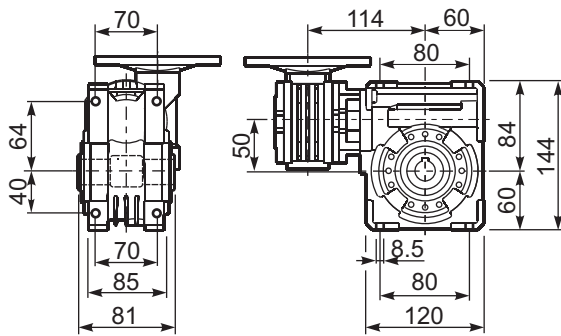

P53Q**BR**... Tork Kolu
Reaction arm

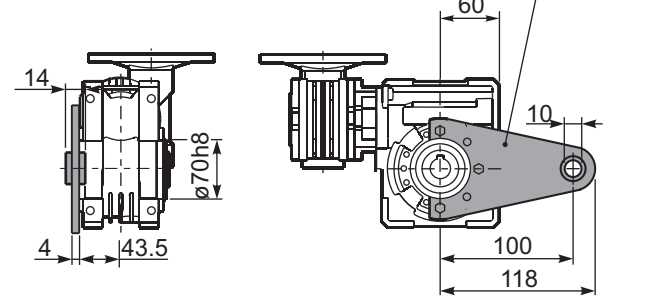

R53Q**FB**... Giriş Mili
Input shaft

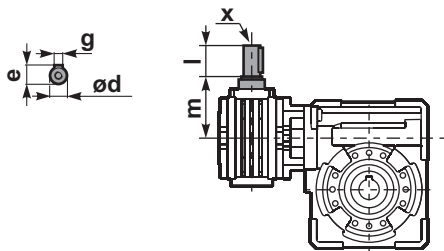

	ød	e	g	l	m	x	Kit Kodu
Tip B	9 h6	10.2	3	20	58	-	K030.5.006 PAM63
Tip S	-	-	-	-	-	-	-

P53Q.....**S**... Tek Çıkış Mili
Single Shaft

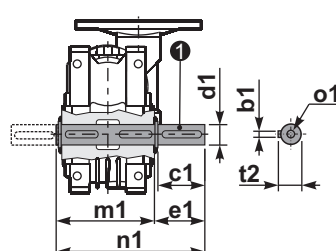

① Kit Kodu K050.5.028 Tip B
Kit Kodu KS050.5.030 Tip S

P53Q.....**D**... Çift Çıkış Mili
Double Shaft

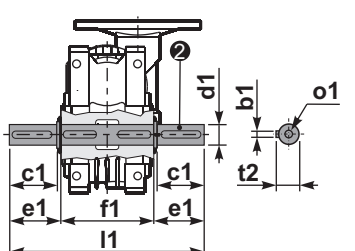

② Kit Kodu K050.5.029 Tip B
Kit Kodu KS050.5.031 Tip S

	b1	c1	d1	e1	f1	l1	m1	n1	t2	o1
Tip B	8	52	25 ^{-0.005} _{-0.020}	59.5	81	200	86.5	146	28	M8x20
Tip S	8	50	24 ^{-0.005} _{-0.020}	68.8	81	218	86.5	155	27	M8x20

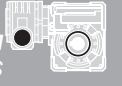

HIZLI SEÇİM / Quick Selection

Giriş Devri (n₁) = 1400 d/d

Çıkış devri n ₂ [d/d]	Tahvil i	Motor gücü P _{1M} [kW]	Çıkış Momenti M _{2M} [Nm]	Servis Faktörü f.s.	Nominal güç P _{1R} [kW]	Nominal moment M _{2R} [Nm]	Uygun B5 motor Flanşları		Uygun B14 motor flanşları		Dinamik verim RD	Modül [mm]	Tahvil kodu
							-A	-B	-O	-P			
							56	63	56	63			
5.6	252	0.18	142	1.6	0.29	230	B		B-C		46	2.7	01
3.9	360	0.18	181	1.3	0.23	230	B		B-C		41	2.7	02
2.6	540	0.12	164	1.4	0.17	230	B		B-C		37	2.7	03
1.9	720	0.12	200	1.1	0.14	230	B		B-C		34	2.7	04
1.3	1080	0.12	265	0.9	0.10	230	B		B-C		30	2.7	05
1.0	1440	0.12*	230	<0.8	0.09	230	B		B-C		27	2.7	06
0.5	2745	0.12*	230	<0.8	0.05	230	B		B-C		23	2.1	07

Uygun Motor Flanşları
Motor Flanges Available

B) Burç ile montaj yapılabilir
Supplied with Reduction Bushing

B) Burç Kullanılmadan Montajı Yapılabilir
Available on Request without Reduction Bushing

C) Teminal Kutusu flanş pozisyonu
Motor Flange Holes Position

* Tablolarda verilen değerlerin üzerindeki motor güçleri için seçimleri M_{2R} değerini referans alarak yapınız.
Power higher than the maximum one which can be supported by the gearbox. Select according to the torque M_{2R}

TR 63Q gövde sonsuz vidalı redüktörler ömürlük sentetik yağ ile yağlanmıştır. V5-V6 montaj pozisyonları için teknik ofisimiz ile iletişime geçiniz.
Tablo 1'de uygun yağ seçenekleri ve yağlama miktarları tanımlanmıştır.
Tablo 2'de izin verilebilir radyal ve eksenel yükler tanımlanmıştır.

EN Unit 63Q is supplied with synthetic oil, providing "long life" lubrication. For mounting position V5-V6 please contact us.
See table 1 for lubrication and recommended quantity.
In table 2 please see possible radial loads and axial loads on the gearbox.

YAĞLAMA

0.30 Lt.

Yağ Miktarı 0.30/0.03 Lt.

LUBRICATON

Oil Quantity 0.30/0.03 Lt.

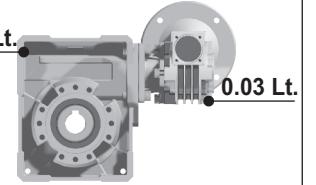

AGIP Telium VSF 320

SHELL Omala S4 WE 320

Daha fazla ayrıntı için internet sitemizi inceleyiniz.
For all details on lubrication and plugs check our website

Tablo 1

RADYAL VE EKSENEL YÜKLER / RADIAL AND AXIAL LOADS

Çıkış Mili

Output Shaft

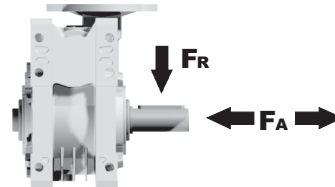

n ₂ [d/d]	FA [N]	FR [N]
25	700	3800
15	800	4000

Giriş Mili

Input Shaft

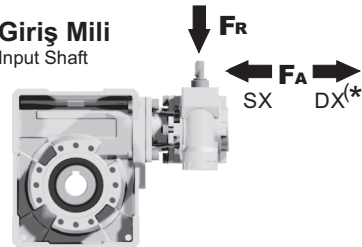

n ₁ [d/d]	FA [N]	FR [N]
1400	20	100

*DX yönünde eksenel yüke izin verilmez
Strong axial loads in the DX direction are not allowed.

Tablo 2

P63Q**FB**... Standart Redüktör
Basic wormbox

Ağırlık
Gearbox
weight **7.25 kg**

M. Flanşlar	Kit Kodu	øF	A
56B5	K030.4.041	120	61.5
63B5	K030.4.042	140	62.5
56B14	K030.4.046	80	61.5
63B14	K030.4.045	90	62.5

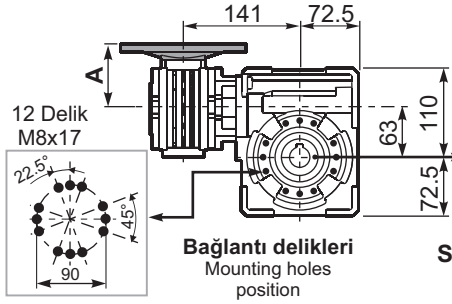
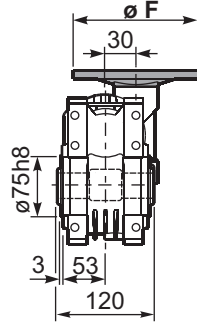

Bağlantı delikleri
Mounting holes
position

Standart Kovan Mil
Hollow shaft

Özel
On Request

P63Q**FC**... Kare Çıkış Flanşı
Square flange

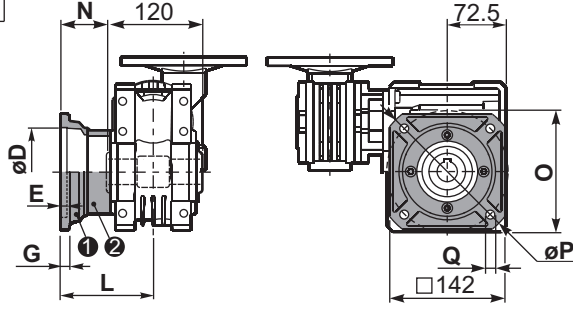

Tip B	øD	E	G	L	N	O	P	Q	Kit Kodu
FC	115 ^{+0.20} / _{+0.15}	6	12	86	26	150	180	11	1 KQ63.9.010 2 -
FL	115 ^{+0.20} / _{+0.15}	6	12	116	56	150	180	11	1 KQ63.9.010 2 K063.0.200

P63Q**F1**... Yuvarlak Çıkış Flanşı
Round flange

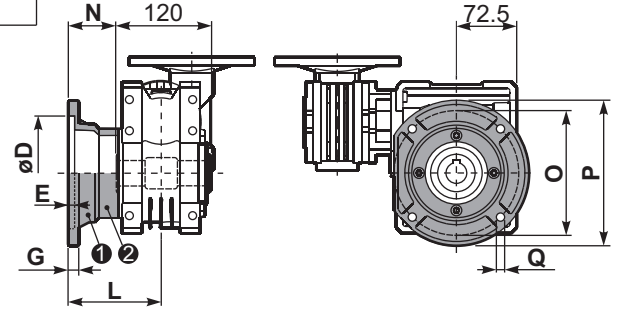

Tip S	øD	E	G	L	N	O	P	Q	Kit Kodu
F1	130 ^{+0.20} / _{+0.15}	7	13	110	50	165	200	13	1 KS070.9.013 2 -
F2	115 ^{+0.20} / _{+0.15}	7	13	124	64	150	175	11	1 KS063.9.013 2 -
F3	110 ^{+0.035} / ₀	5	11	90	30	130	160	10	1 KS063.9.011 2 -

P63Q**FB**... Ayak
Feet

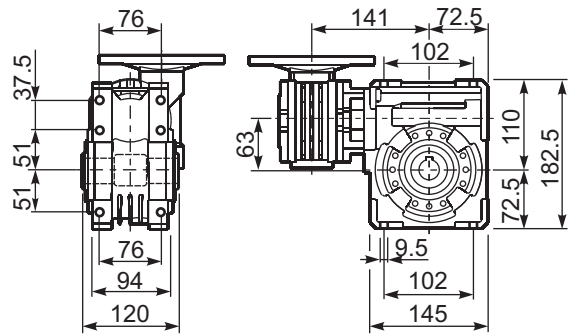

P63Q**BR**... Tork Kolu
Reaction arm

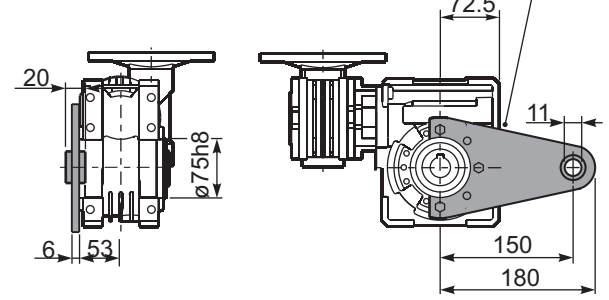

Kit Kodu K063.9.027

R63Q**FB**... Giriş Mili
Input shaft

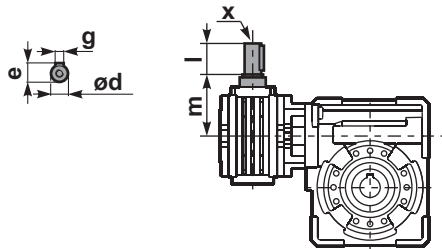

Tip B	ød	e	g	l	m	x	Kit Kodu
Tip B	9 h6	10.2	3	20	58	-	1 K030.5.006 PAM63 2 -
Tip S	-	-	-	-	-	-	1 - 2 -

P63Q.....**S**... Tek Çıkış Mili
Single Shaft

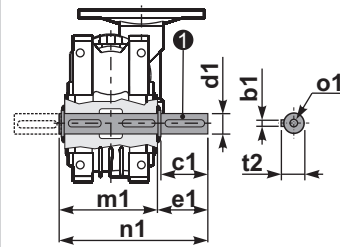

P63Q.....**D**... Çift Çıkış Mili
Double Shaft

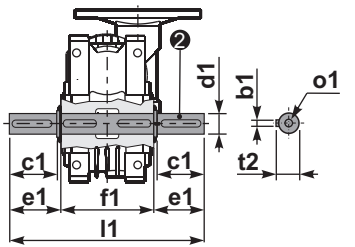

1 Kit Kodu K063.5.028 Tip B

2 Kit Kodu K063.5.029 Tip B

Tip B	b1	c1	d1	e1	f1	l1	m1	n1	t2	o1
Tip B	8	60	25 ^{-0.005} / _{-0.020}	63.2	120	246.4	126.8	190	28	M8x20
Tip S	-	-	-	-	-	-	-	-	-	-

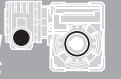

HIZLI SEÇİM / Quick Selection

Giriş Devri (n_1) = 1400 d/d

Çıkış devri n_2 [d/d]	Tahvil i	Motor gücü P_{1M} [kW]	Çıkış Momenti M_{2M} [Nm]	Servis Faktörü f.s.	Nominal güç P_{1R} [kW]	Nominal moment M_{2R} [Nm]	Uygun B5 motor Flanşları		Uygun B14 motor flanşları			Dinamik verim RD	Modül [mm]	Tahvil kodu
							-B	-C	-O	-P	-Q			
							63	71	56	63	71			
5.6	252	0.25	198	1.3	0.33	265	B		B-C	B-C		46	2.7	01
3.9	360	0.18	186	1.4	0.26	265	B		B-C	B-C		42	2.7	02
2.8	504	0.18	241	1.1	0.20	265	B		B-C	B-C		39	2.7	03
1.9	756	0.12	204	1.3	0.16	265	B		B-C	B-C		33	2.7	04
1.4	1008	0.12	256	1.0	0.12	265	B		B-C	B-C		31	2.7	05
1.1	1332	0.12*	265	<0.8	0.10	265	B		B-C	B-C		30	2.7	06
0.8	1656	0.12*	265	<0.8	0.08	265	B		B-C	B-C		28	2.7	07
0.6	2160	0.12*	265	<0.8	0.07	265	B		B-C	B-C		26	2.7	08
0.6	2520	0.12*	265	<0.8	0.06	265	B		B-C	B-C		25	2.7	09

Uygun Motor Flanşları
Motor Flanges Available

B) Burç ile montaj yapılabilir
Supplied with Reduction Bushing

B) Burç Kullanılmadan Montajı Yapılabilir
Available on Request without Reduction Bushing

C) Teminal Kutusu flanş pozisyonu
Motor Flange Holes Position

* Tablolarda verilen değerlerin üzerindeki motor güçleri için seçimleri M_{2R} değerini referans alarak yapınız.
Power higher than the maximum one which can be supported by the gearbox. Select according to the torque M_{2R}

TR 64Q gövde sonsuz vidalı redüktörler ömürlük sentetik yağ ile yağlanmıştır. V5-V6 montaj pozisyonları için teknik ofisimiz ile iletişime geçiniz. Tablo 1'de uygun yağ seçenekleri ve yağlama miktarları tanımlanmıştır. Tablo 2'de izin verilebilir radyal ve eksenel yükler tanımlanmıştır.

EN Unit 64Q is supplied with synthetic oil, providing "long life" lubrication. For mounting position V5-V6 please contact us. See table 1 for lubrication and recommended quantity. In table 2 please see possible radial loads and axial loads on the gearbox.

YAĞLAMA 0.30 Lt.
Yağ Miktarı 0.30/0.09 Lt.
LUBRICATON
Oil Quantity 0.30/0.09 Lt.

AGIP Telium VSF 320 SHELL Omala S4 WE 320

Daha fazla ayrıntı için internet sitemizi inceleyiniz. **Tablo 1**
For all details on lubrication and plugs check our website

RADYAL VE EKSENEL YÜKLER / RADIAL AND AXIAL LOADS

Çıkış Mili
Output Shaft

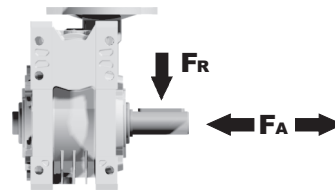

n_2 [d/d]	FA [N]	FR [N]
25	700	3800
15	800	4000

Giriş Mili
Input Shaft

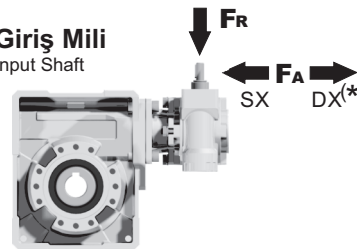

n_1 [d/d]	FA [N]	FR [N]
1400	42	210

*DX yönünde eksenel yüke izin verilmez
Strong axial loads in the DX direction are not allowed.

Tablo 2

P64QFB... Standart Redüktör
Basic wormbox

Ağırlık
Gearbox
weight **7.25 kg**

M. Flanşlar	Kit Kodu	øF	A
63B5	K050.4.041	138	74
71B5	K050.4.042	160	71.5
56B14	KC40.4.049	80	71.5
63B14	K050.4.047	90	74
71B14	K050.4.045	105	71.5

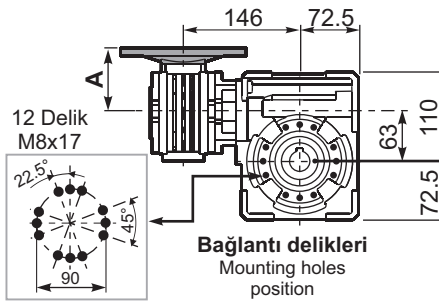
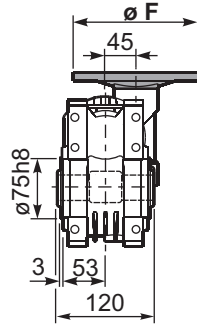

Bağlantı delikleri
Mounting holes
position

Standart Kovan Mil
Hollow shaft

Özel
On Request

P64QFC... Kare Çıkış Flanşı
Square flange

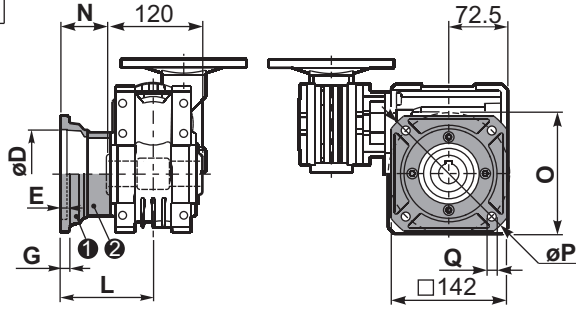

P64QF1... Yuvarlak Çıkış Flanşı
Round flange

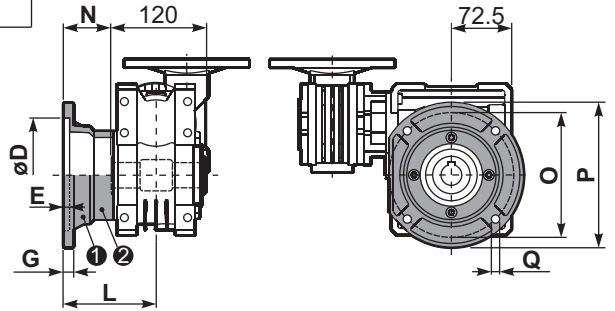

Tip B	øD	E	G	L	N	O	P	Q	Kit Kodu
FC	115 ^{+0.20} / _{+0.15}	6	12	86	26	150	180	11	1 KQ63.9.010 2 -
FL	115 ^{+0.20} / _{+0.15}	6	12	116	56	150	180	11	1 KQ63.9.010 2 K063.0.200

Tip S	øD	E	G	L	N	O	P	Q	Kit Kodu
F1	130 ^{+0.20} / _{+0.15}	7	13	110	50	165	200	13	1 KS070.9.013 2 -
F2	115 ^{+0.20} / _{+0.15}	7	13	124	64	150	175	11	1 KS063.9.013 2 -
F3	110 ^{+0.035} / ₀	5	11	90	30	130	160	10	1 KS063.9.011 2 -

P64QFB... Ayak
Feet

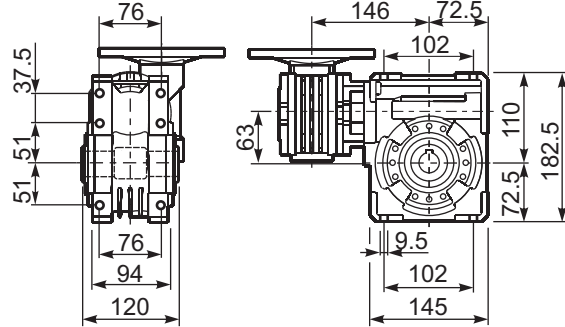

P64QBR... Tork Kolu
Reaction arm

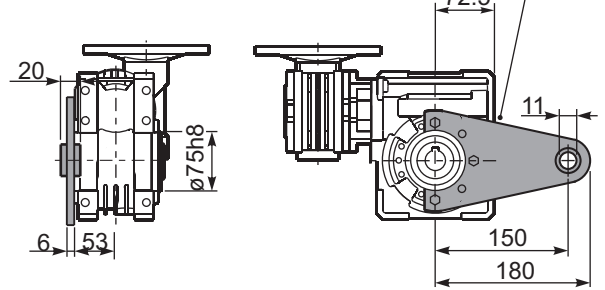

Kit Kodu K063.9.027

R64QFB... Giriş Mili
Input shaft

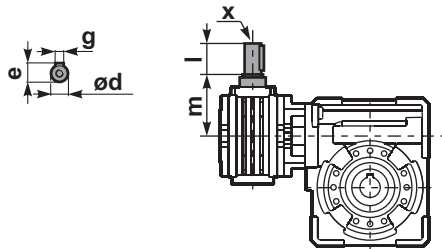

P64Q.....S... Tek Çıkış Mili
Single Shaft

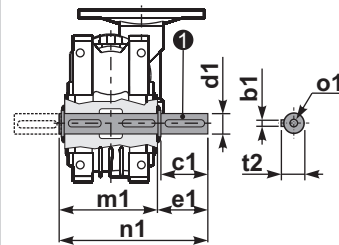

P64Q.....D... Çift Çıkış Mili
Double Shaft

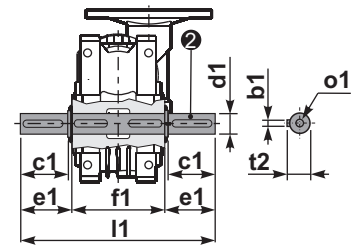

1 Kit Kodu K063.5.028 Tip B

2 Kit Kodu K063.5.029 Tip B

Tip B	ød	e	g	l	m	x	Kit Kodu
Tip B	11 h6	12.5	4	30	68	-	1 K045.5.006 PAM71 2 -
Tip S	-	-	-	-	-	-	1 - 2 -

Tip B	b1	c1	d1	e1	f1	l1	m1	n1	t2	o1
Tip B	8	60	25 ^{-0.005} / _{-0.020}	63.2	120	246.4	126.8	190	28	M8x20
Tip S	-	-	-	-	-	-	-	-	-	-

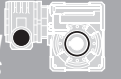

HIZLI SEÇİM / Quick Selection

Giriş Devri (n_1) = 1400 d/d

Çıkış devri n_2 [d/d]	Tahvil i	Motor gücü P_{1M} [kW]	Çıkış Momenti M_{2M} [Nm]	Servis Faktörü f.s.	Nominal güç P_{1R} [kW]	Nominal moment M_{2R} [Nm]	Uygun B5 motor Flanşları		Uygun B14 motor flanşları			Dinamik verim RD	Modül [mm]	Tahvil kodu
							-B	-C	-O	-P	-Q			
							63	71	56	63	71			
5	280	0.37	403	0.9	0.33	359	B		B-C	B-C		57	3.10	01
3.5	400	0.25	314	1.1	0.29	359	B		B-C	B-C		46	3.10	02
2.5	560	0.25	420	0.9	0.21	359	B		B-C	B-C		44	3.10	03
1.7	840	0.18	423	0.8	0.15	359	B		B-C	B-C		41	3.10	04
1.3	1120	0.12	339	1.1	0.13	359	B		B-C	B-C		37	3.10	05
0.9	1480	0.09	336	1.1	0.10	359	B		B-C	B-C		37	3.10	06
0.8	1840	0.09	373	1.0	0.09	359	B		B-C	B-C		33	3.10	07
0.6	2400	0.06	275	1.3	0.08	359	B		B-C	B-C		28	3.10	08
0.5	2800	0.06	298	1.2	0.07	359	B		B-C	B-C		26	3.10	09
0.3	4080	0.06	250	1.4	0.09	359	B		B-C	B-C		15	3.10	10

Uygun Motor Flanşları
Motor Flanges Available

B) Burç ile montaj yapılabilir
Supplied with Reduction Bushing

B) Burç Kullanılmadan Montajı Yapılabilir
Available on Request without Reduction Bushing

C) Teminal Kutusu flanş pozisyonu
Motor Flange Holes Position

TR 74Q gövde sonsuz vidalı redüktörler ömürlük sentetik yağ ile yağlanmıştır. V5-V6 montaj pozisyonları için teknik ofisimiz ile iletişime geçiniz. Tablo 1'de uygun yağ seçenekleri ve yağlama miktarları tanımlanmıştır. Tablo 2'de izin verilebilir radyal ve eksenel yükler tanımlanmıştır.

EN Unit 74Q is supplied with synthetic oil, providing "long life" lubrication. For mounting position V5-V6 please contact us. See table 1 for lubrication and recommended quantity. In table 2 please see possible radial loads and axial loads on the gearbox.

YAĞLAMA

0.40 Lt.

Yağ Miktarı 0.40/0.09 Lt.
LUBRICATON
Oil Quantity 0.30/0.09 Lt.

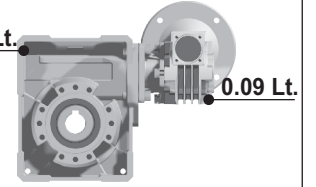

AGIP Telium VSF 320

SHELL Omala S4 WE 320

Daha fazla ayrıntı için internet sitemizi inceleyiniz.

For all details on lubrication and plugs check our website

Tablo 1

RADYAL VE EKSENEL YÜKLER / RADIAL AND AXIAL LOADS

Çıkış Mili
Output Shaft

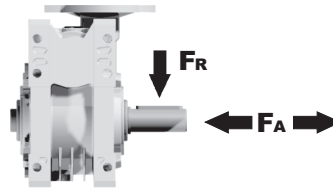

n_2 [d/d]	FA [N]	FR [N]
25	880	4400
15	1000	5000

Giriş Mili
Input Shaft

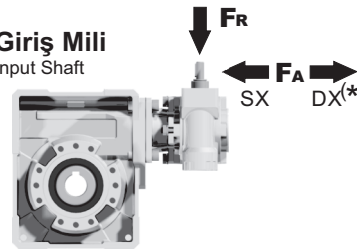

n_1 [d/d]	FA [N]	FR [N]
1400	42	210

*DX yönünde eksenel yüke izin verilmez
Strong axial loads in the DX direction are not allowed.

Tablo 2

P74QFB... Standart Redüktör
Basic wormbox

M. Flanşlar	Kit Kodu	øF	A
63B5	K050.4.041	138	74
71B5	K050.4.042	160	71.5
56B14	KC40.4.049	80	71.5
63B14	K050.4.047	90	74
71B14	K050.4.045	105	71.5

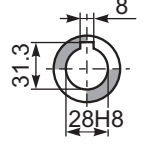
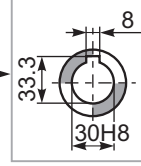
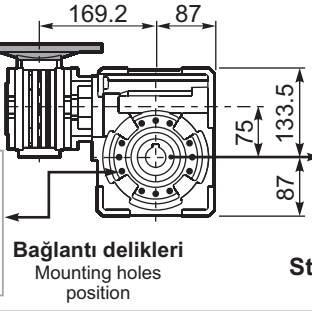
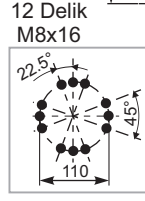
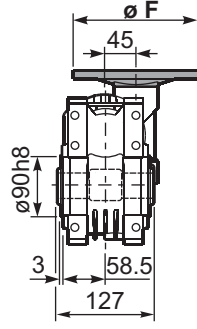

Ağırlık
Gearbox
weight **11.4 kg**

P74QFC... Kare Çıkış Flanşı
Square flange

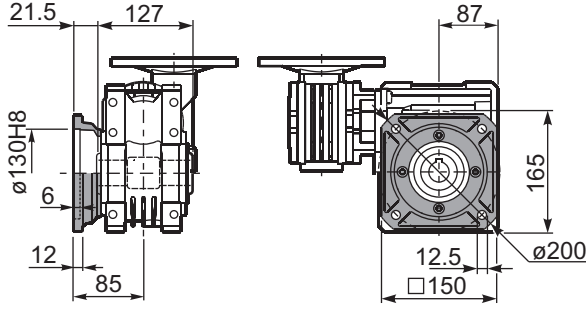

P74QFL... Yuvarlak Çıkış Flanşı
Round flange

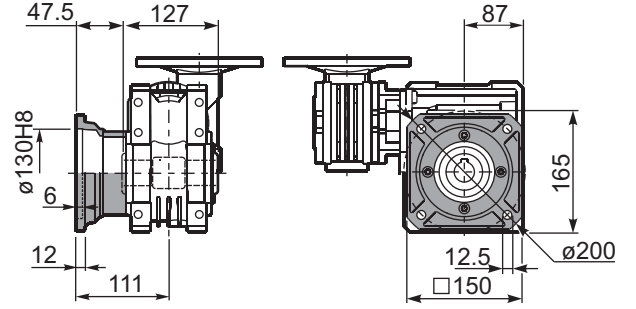

P74QFB... Ayak
Feet

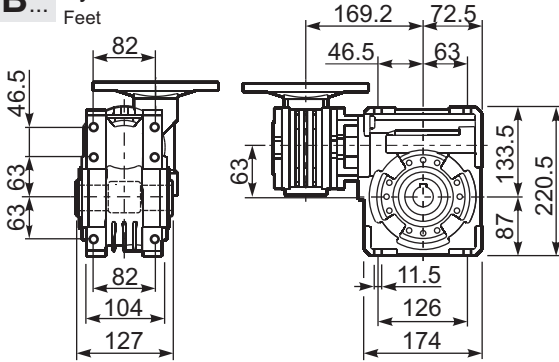

P74QBR... Tork Kolu
Reaction arm

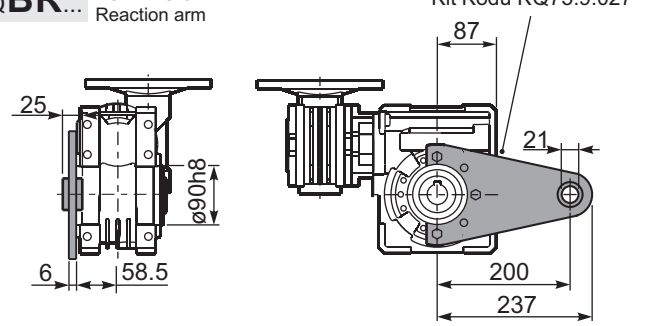

R74QFB... Giriş Mili
Input shaft

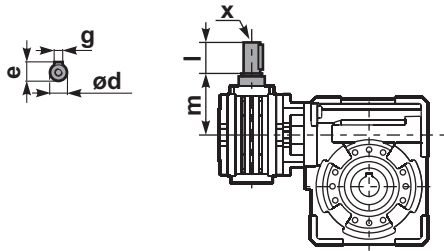

P74Q.....S... Tek Çıkış Mili
Single Shaft

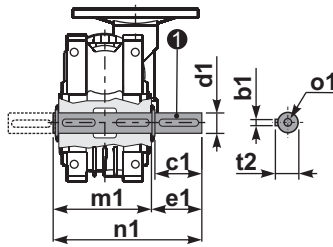

P74Q.....D... Çift Çıkış Mili
Double Shaft

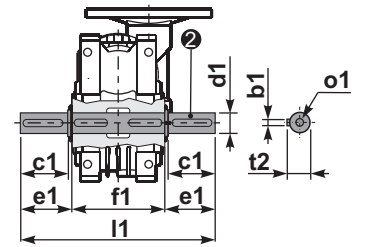

① Kit Kodu KQ75.5.028 Standart
Kit Kodu KQ75.5.026 Özel

② Kit Kodu KQ75.5.029 Standart
Kit Kodu KQ75.5.027 Özel

	ød	e	g	l	m	x	Kit Kodu
Tip B	11 h6	12.5	4	30	68	-	① K045.5.006 PAM71 ② -
Tip S	-	-	-	-	-	-	① - ② -

	b1	c1	d1	e1	f1	l1	m1	n1	t2	o1
Standart	8	60	30 ^{-0.005} _{-0.020}	65	127	255	134	199	33	M8x20
Özel	8	60	28 ^{-0.005} _{-0.020}	65	127	255	134	199	31	M8x20

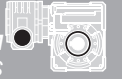

HIZLI SEÇİM / Quick Selection

Giriş Devri (n₁) = 1400 d/d

Çıkış devri n ₂ [d/d]	Tahvil i	Motor gücü P _{1M} [kW]	Çıkış Momenti M _{2M} [Nm]	Servis Faktörü f.s.	Nominal güç P _{1R} [kW]	Nominal moment M _{2R} [Nm]	Uygun B5 motor Flanşları		Uygun B14 motor flanşları			Dinamik verim RD	Modül [mm]	Tahvil kodu
							-B	-C	-O	-P	-Q			
							63	71	56	63	71			
10	140	0.37	205	1.8	0.66	368	B		B-C	B-C		58	4.5	01
7.1	196	0.37	257	1.4	0.53	368	B		B-C	B-C		52	4.7	02
5.0	280	0.37	332	1.6	0.58	518	B		B-C	B-C		47	4.7	03
3.6	392	0.37	435	1.2	0.44	518	B		B-C	B-C		44	4.7	04
2.4	588	0.25	371	1.4	0.35	518	B		B-C	B-C		37	4.7	05
1.8	784	0.25	455	1.1	0.28	518	B		B-C	B-C		34	4.7	06
1.4	1036	0.18	420	1.2	0.22	518	B		B-C	B-C		33	4.7	07
1.1	1288	0.18	474	1.1	0.20	518	B		B-C	B-C		30	4.7	08
0.7	1960	0.12	449	1.2	0.14	518	B		B-C	B-C		28	4.7	09
0.5	2856	0.12	584	0.9	0.11	518	B		B-C	B-C		25	4.7	10

Uygun Motor Flanşları
Motor Flanges AvailableB) Burç ile montaj yapılabilir
Supplied with Reduction BushingB) Burç Kullanılmadan Montajı Yapılabilir
Available on Request without Reduction BushingC) Teminal Kutusu flanş pozisyonu
Motor Flange Holes Position

TR 84Q gövde sonsuz vidalı redüktörler ömürlük sentetik yağ ile yağlanmıştır. V5-V6 montaj pozisyonları için teknik ofisimiz ile iletişime geçiniz.

Tablo 1'de uygun yağ seçenekleri ve yağlama miktarları tanımlanmıştır.

Tablo 2'de izin verilebilir radyal ve aksel yükler tanımlanmıştır.

EN Unit 84Q is supplied with synthetic oil, providing "long life" lubrication. For mounting position V5-V6 please contact us. See table 1 for lubrication and recommended quantity. In table 2 please see possible radial loads and axial loads on the gearbox.

B3	B6	B7	B8	V5	V6
1.2/0.09LT	1.2/0.09 LT	1.2/0.09 LT	1.2/0.09 LT	1.2/0.09 LT	1.2/0.09 LT
AGIP Telium VSF 320			SHELL Omala S4 WE 320		

Daha fazla ayrıntı için internet sitemizi inceleyiniz.
For all details on lubrication and plugs check our website

Tablo 1

RADYAL VE EKSENEL YÜKLER / RADIAL AND AXIAL LOADS

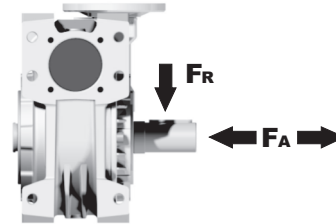
Çıkış Mili
Output Shaft

n ₂ [d/d]	FA [N]	FR [N]
25	1000	5000
15	1160	5800

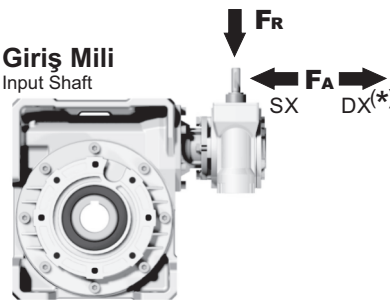
Giriş Mili
Input Shaft

n ₁ [d/d]	FA [N]	FR [N]
1400	42	210

*DX yönünde aksel yüke izin verilmez
Strong axial loads in the DX direction are not allowed.

Tablo 2

P84QFB... Standart Redüktör
Basic wormbox

Ağırlık
Gearbox
weight **16.2 kg**

M. Flanşlar	Kit Kodu	øF	A
63B5	K050.4.041	138	74
71B5	K050.4.042	160	71.5
56B14	KC40.4.049	80	71.5
63B14	K050.4.047	90	74
71B14	K050.4.045	105	71.5

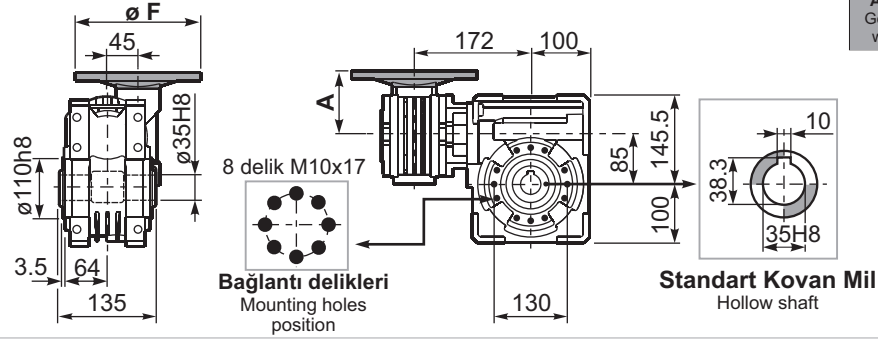

P84QFC... Çıkış Flanşı
Output flange

P84QF1... Çıkış Flanşı
Output flange

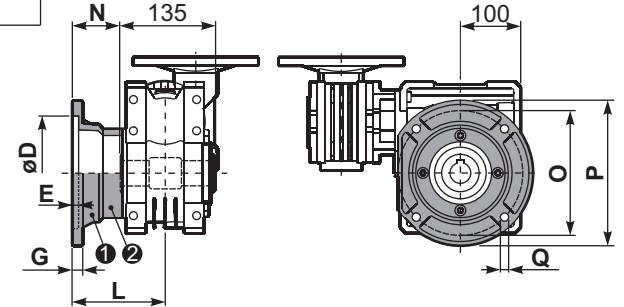
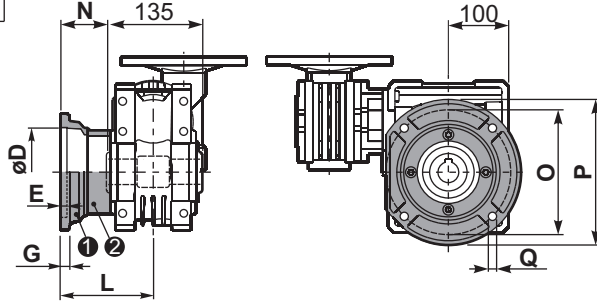

Tip B	øD	E	G	L	N	O	P	Q	Kit Kodu
FC	152 ^{+0.06} / _{+0.00}	5	16	108	40.5	176	205	13	1 K085.9.010 2 -
FL	152 ^{+0.06} / _{+0.00}	5	16	148.5	81	176	205	13	1 K085.9.010 2 K085.0.201

Tip S	øD	E	G	L	N	O	P	Q	Kit Kodu
F1	130 H7	5	13	117.5	50	165	200	11.5	1 KS085.9.012 2 -
F2	152 ^{+0.06} / _{+0.00}	5	15	147.5	80	180	205	12.5	1 KS085.9.013 2 -
F4	130 H7	5	13	106.5	39	165	200	13	1 KS085.9.015 2 -

P84QFB... Ayak
Feet

P84QBR... Tork Kolu
Reaction arm

Kit Kodu K085.9.027

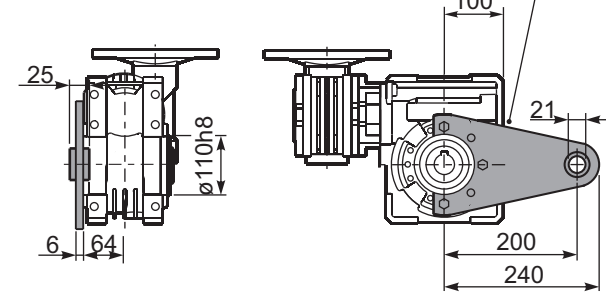
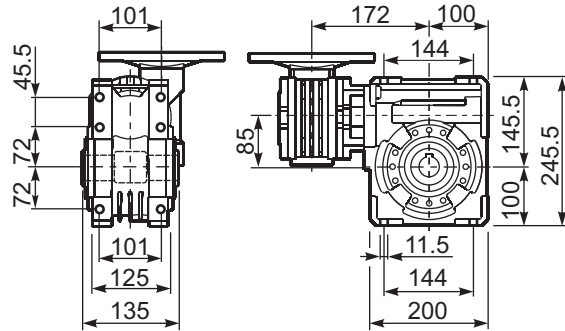

R84QFB... Giriş Mili
Input shaft

P84Q.....S... Tek Çıkış Mili
Single Shaft

P84Q.....D... Çift Çıkış Mili
Double Shaft

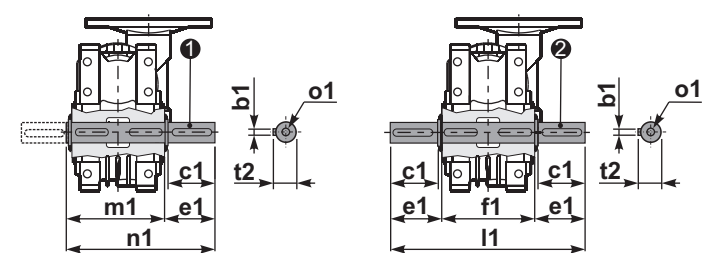
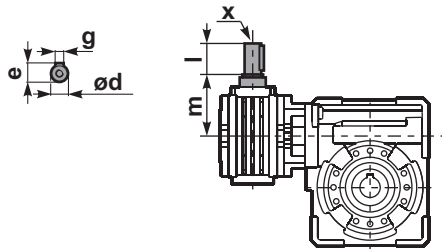

1 Kit Kodu K085.5.028 Tip B

2 Kit Kodu K085.5.029 Tip B

Tip B	ød	e	g	l	m	x	Kit Kodu
Tip B	11 h6	12.5	4	30	68	-	1 K045.5.006 PAM71 2 -
Tip S	-	-	-	-	-	-	1 - 2 -

Tip B	b1	c1	d1	e1	f1	l1	m1	n1	t2	o1
Tip B	10	60	35 ^{-0.005} / _{-0.020}	73.5	135	282	141	214.5	38	M10x23
Tip S	-	-	-	-	-	-	-	-	-	-

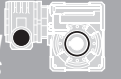

HIZLI SEÇİM / Quick Selection

Giriş Devri (n_1) = 1400 d/d

Çıkış devri n_2 [d/d]	Tahvil i	Motor gücü P_{1M} [kW]	Çıkış Momenti M_{2M} [Nm]	Servis Faktörü f.s.	Nominal güç P_{1R} [kW]	Nominal moment M_{2R} [Nm]	Uygun B5 motor Flanşları			Uygun B14 motor flanşları				Dinamik verim RD	Modül [mm]	Tahvil kodu
							-B	-C	-D	-O	-P	-Q	-R			
							63	71	80	56	63	71	80			
6.7	210	0.75	591	1.5	1.1	863	B	B			B-C	B		55	5.6	01
4.7	300	0.75	752	1.3	0.97	978	B	B			B-C	B		49	5.6	02
3.3	420	0.55	741	1.3	0.73	978	B	B			B-C	B		47	5.6	03
2.6	540	0.55	851	1.1	0.63	978	B	B			B-C	B		42	5.6	04
1.8	780	0.37	748	1.3	0.48	978	B	B			B-C	B		38	5.6	05
1.3	1080	0.37	1009	1.0	0.36	978	B			B-C	B-C			37	5.6	06
1.1	1290	0.25	770	1.3	0.32	978	B			B-C	B-C			35	5.6	07
0.8	1800	0.25	921	1.1	0.27	978	B			B-C	B-C			30	5.6	08
0.7	2040	0.18	751	1.3	0.23	978	B			B-C	B-C			30	5.6	09
0.6	2400	0.18	825	1.2	0.21	978	B			B-C	B-C			28	5.6	10
0.5	3000	0.18	958	1.0	0.18	978	B			B-C	B-C			26	5.6	11

Uygun Motor Flanşları
Motor Flanges Available

B) Burç ile montaj yapılabilir
Supplied with Reduction Bushing

B) Burç Kullanılmadan Montajı Yapılabilir
Available on Request without Reduction Bushing

C) Terminal Kutusu flanş pozisyonu
Motor Flange Holes Position

TR 15Q gövde redüktörler yağsız olarak sevk edilir. Redüktör üzerinde havalandırma tapası, yağ göstergesi ve tahliye tapası mevcuttur. Mineral yağlar bu ekipmanlar ile birlikte kullanılır. Sentetik yağ kullanılmak istenirse bu ekipmanların körtapa ile değiştirilmesi önerilir. Tablo 1'de montaj pozisyonuna göre uygun yağ miktarları tanımlanmıştır. Tablo 2'de izin verilebilir radyal ve eksenel yük değerleri tanımlanmıştır.

EN Unit 15Q is supplied without lubricant and equipped with a breather, level and drain plugs. User can add mineral oil keeping existing plugs. Should the user wish to fill it with synthetic oil, it is recommended to replace the existing plugs with a type that are closed. Gearbox 050 is supplied lubricated for life. See tab.1 for oils and recommended quantity. In tab.2 there are radial loads and axial loads applicable to the gearbox.

B3	B6	B7	B8	V5	V6
2.0/0.14LT	1.35/0.14 LT	1.35/0.14 LT	2.0/0.14 LT	2.0/0.14 LT	2.0/0.14 LT
AGIP Blasia 460					

Daha fazla ayrıntı için internet sitemizi inceleyiniz.
For all details on lubrication and plugs check our website

Tablo 1

RADYAL VE EKSENEL YÜKLER / RADIAL AND AXIAL LOADS

Çıkış Mili Output Shaft

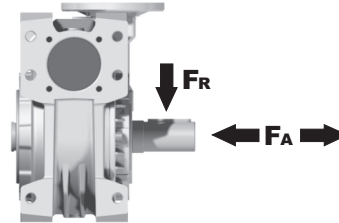

n_2 [d/d]	FA [N]	FR [N]
25	1200	6000
15	1400	7000

Giriş Mili Input Shaft

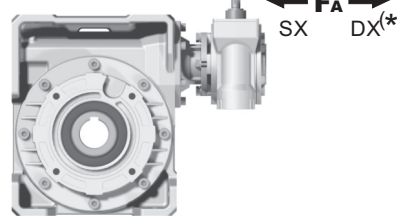

n_1 [d/d]	FA [N]	FR [N]
1400	76	380

*DX yönünde eksenel yüke izin verilmez
Strong axial loads in the DX direction are not allowed.

Tablo 2

P15QFB... Standart Redüktör
Basic wormbox

Ağırlık
Gearbox
weight **38.8 kg**

M. Flanşları	Kit Kodu	øF	A
63B5	K050.4.041	138	78.5
71B5	K050.4.042	160	76
80B5	K050.4.043	200	76.5
56B14	KC40.4.049	80	76
63B14	K050.4.047	90	78.5
71B14	K050.4.045	105	76
80B14	K050.4.046	120	76.5

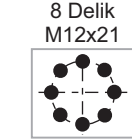
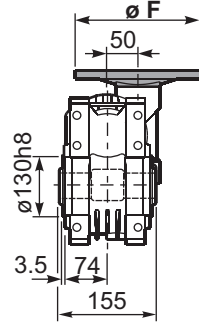

Bağlantı delikleri
Mounting holes
position

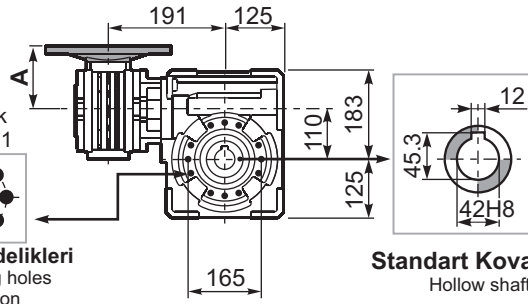

Standart Kovan Mil
Hollow shaft

P15QFC... Çıkış Flanşı
Output flange

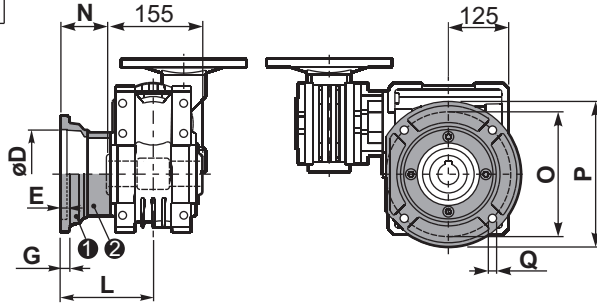

Tip B	øD	E	G	L	N	O	P	Q	Kit Kodu
FC	170 ^{+0.083} / _{+0.043}	11	16.5	131.5	54	230	270	13	1 K110.9.010 2 - 3 -
FL	170 ^{+0.083} / _{+0.043}	11	16.5	179.5	102	230	270	13	1 K110.9.011 2 - 3 -

P15QF1... Çıkış Flanşı
Output flange

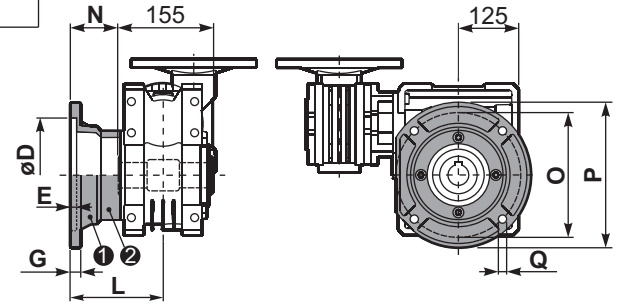

Tip S	øD	E	G	L	N	O	P	Q	Kit Kodu
F1	180 ^{+0.040} / ₀	5	18	150	72.5	215	250	15	1 KS110.9.014 2 - 3 -
F2	170 ^{+0.083} / _{+0.043}	9.5	15	178	100.5	230	270	13	1 KS110.9.012 2 - 3 -
F3	180 ^{+0.040} / ₀	5	18	130	52.5	215	250	15	1 KS110.9.013 2 - 3 -

P15QFB... Ayak
Feet

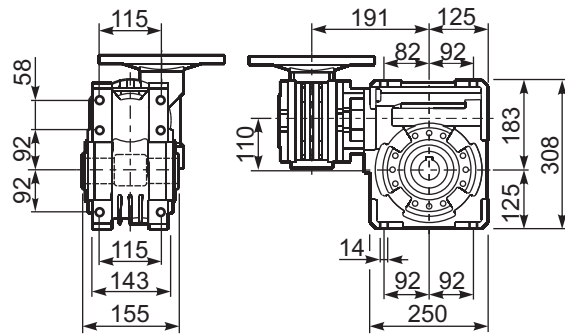

P15QBR... Tork Kolu
Reaction arm

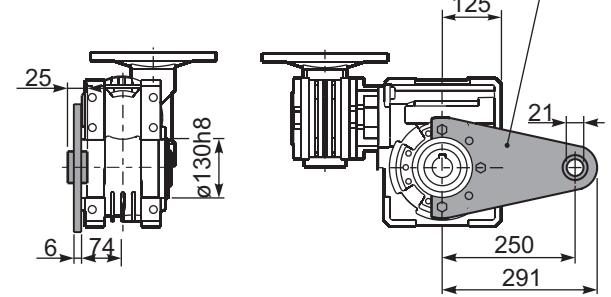

Kit Kodu K110.9.027

R15QFB... Giriş Mili
Input shaft

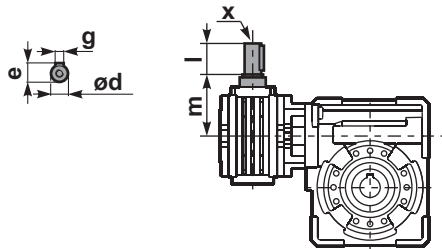

Tip B	ød	e	g	l	m	x	Kit Kodu
Tip B	16 h6	18	5	30	79.5	M6x16	1 K050.5.006 PAM71 2 K050.5.007 PAM80
Tip S	14 h6	16	5	30	79.5	M5x10	1 KS050.5.008 PAM71 2 KS050.5.009 PAM80

P15Q.....S... Tek Çıkış Mili
Single Shaft

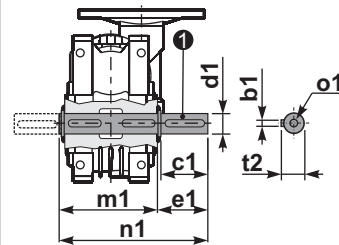

P15Q.....D... Çift Çıkış Mili
Double Shaft

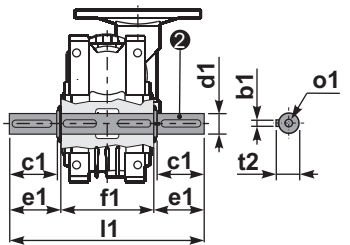

1 Kit Kodu K110.5.028 Tip B

2 Kit Kodu K110.5.029 Tip B

Tip B	b1	c1	d1	e1	f1	l1	m1	n1	t2	o1
Tip B	12	75	42 ^{-0.005} / _{-0.020}	96.5	155	348	163.5	260	45	M12x32
Tip S	-	-	-	-	-	-	-	-	-	-

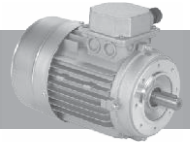

- 1) 230/400V - 50Hz 3 fazlı asenkron indüksiyon motoru
- 2) F klas izolasyon
- 3) S1
- 4) IP 55 koruma
- 5) Boyasız
- 6) Aktarım sırasında çıkış milini korumak için sert plastik kılıf

- 1) 230/400V - 50 Hz three-phase asynchronous induction motor
- 2) Class F insulation
- 3) S1 duty
- 4) IP 55 protection
- 5) Not painted
- 6) Hard plastic sleeve to protect output shaft during the transportation

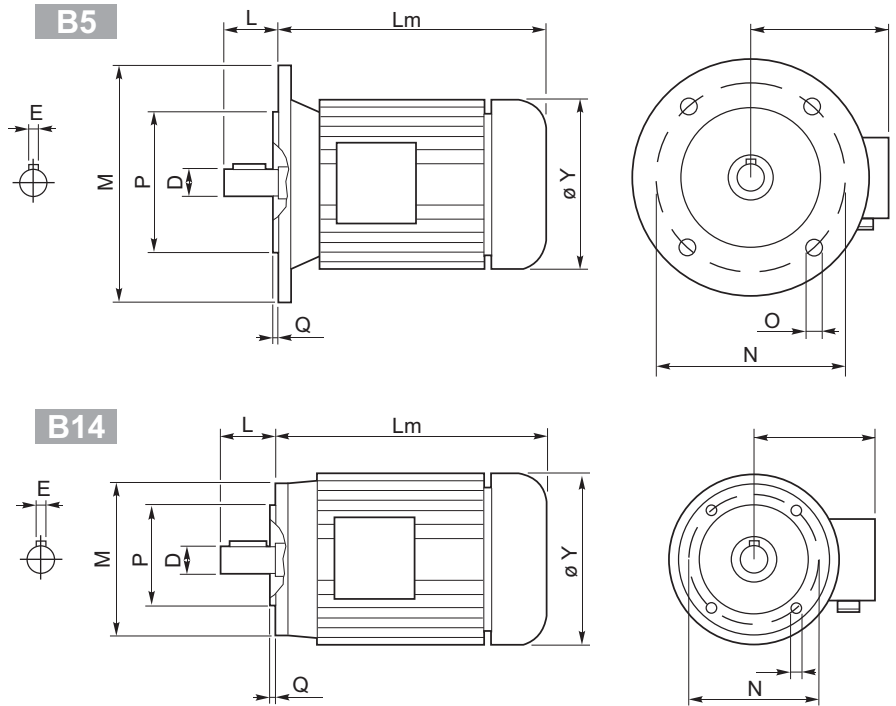

Dış ölçüler ve ağırlık üretici firmaya bağlı olarak farklılık gösterebilir
Outside dimensions and weight may be different according to manufacturers

	2 poli / poles			4 poli / poles			6 poli / poles			B5-B14					B5					B14					Kg	
	kW	Nm	A (400V)	kW	Nm	A (400V)	kW	Nm	A (400V)	D (mm)	E (mm)	L (mm)	Lm (mm)	Y (mm)	AD (mm)	P (mm)	N (mm)	M (mm)	O (mm)	Q (mm)	P (mm)	N (mm)	M (mm)	O (mm)		Q (mm)
56 A	0.09	0.32	0.38	0.06	0.44	0.27	—	—	—	9	3	20	179	108	96	80	100	120	7	2.5	50	65	80	M5	2.5	2.7
56 B	0.12	0.42	0.46	0.09	0.67	0.37	—	—	—																	2.9
63 A	0.18	0.63	0.60	0.12	0.84	0.50	0.09	0.99	0.57	11	4	23	185	120	99	95	115	140	9.5	3	60	75	90	M5	2.5	3.8
63 B	0.25	0.87	0.76	0.18	1.30	0.69	0.12	1.32	0.74																	4.2
71 A	0.37	1.30	1.00	0.25	1.70	0.91	0.18	1.90	0.80	14	5	30	-	130	104	110	130	160	9.5	3.5	70	85	105	M6	2.5	5.9
71 B	0.55	1.90	1.54	0.37	2.52	1.14	0.25	2.72	1.10				225	141	107											6.5
80 A	0.75	2.60	1.85	0.55	3.77	1.51	0.37	3.84	1.18	19	6	40	256	159	127	130	165	200	11.5	3.5	80	100	120	M6	3	8.5
80 B	1.1	3.90	2.64	0.75	5.11	2.57	0.55	5.84	1.80																	10
90 S	1.5	5.00	3.31	1.1	7.45	2.78	0.75	7.92	2.32	24	8	50	-	170	135	130	165	200	11.5	3.5	95	115	140	M8	3	12.5
90 L	2.2	7.50	4.46	1.5	10.2	3.61	1.1	11.6	3.45				280													15
100 LA	3.0	10.0	6.28	2.2	14.8	5.07	1.5	15.4	3.88																	20
100 LB	—	—	—	3.0	20.1	6.66	—	—	—	28	8	60	-	190	148	180	215	250	13	4	110	130	160	M8	3.5	22
112 M	4.0	13.4	8.10	4.0	26.7	8.55	2.2	22.6	5.30				321	210	164											35
132 S	5.5	18.3	11.2	5.5	36.5	11.4	3.0	30.2	7.20	38	10	80	375	244	180	230	265	300	14	4	130	165	200	M10	4	41
	7.5	24.9	15.3										420													51
132 M	—	—	—	7.5	49.4	15.0	4.0	40.0	9.13																	51
				9	61.4	18.5																				
160 M	—	—	—	11	72	21.5	—	—	—	42	12	110	503	335	246	250	300	350	18	5	—	—	—	—	—	79.2
160 L	—	—	—	15	98	29	—	—	—				547													97.5
180 M	—	—	—	18.5	121	35.5	—	—	—	48	14	110	602	366	266	250	300	350	19	5	—	—	—	—	—	170
180 L	—	—	—	22	144	42	—	—	—																	
200 L	—	—	—	30	196	53	—	—	—	55	16	110	670	405	341	300	350	400	19	5	—	—	—	—	—	240
225 S	—	—	—	37	240	69	—	—	—	60	18	140	748	463	360	350	400	450	19	5	—	—	—	—	—	305
225 M	—	—	—	45	292	84	—	—	—																	310

MONOBLOK YÜKSEK VERİMLİ MODÜLER VE KOMPAKT ÜRÜNLER
MONOBLOCK MODULAR & COMPACT PRODUCTS WITH HIGH ENERGY EFFICIENCY DRIVE



**PARALEL MİLLİ
REDÜKTÖR**
PARALLEL SHAFT
GEARBOXES

Gövde Büyüküğü Size	Nominal Çıkış Momenti Rated Output Torque
063	300 Nm
080	650 Nm
100	1.400 Nm
125	2.750 Nm
140	4.200 Nm
160	6.000 Nm
180	7.500 Nm
200	12.000 Nm
225	18.000 Nm
250	26.550 Nm
280	30.000 Nm
320	45.000 Nm
360	70.000 Nm



**KONİK HELİSEL DİŞLİ
REDÜKTÖR**
BEVEL HELICAL - RIGHTANGLE
GEARBOXES

Gövde Büyüküğü Size	Nominal Çıkış Momenti Rated Output Torque
063	300 Nm
080	650 Nm
100	1.400 Nm
125	2.750 Nm
140	4.200 Nm
160	6.000 Nm
180	7.500 Nm
200	12.000 Nm
225	18.000 Nm
250	26.550 Nm
280	30.000 Nm
320	45.000 Nm
360	70.000 Nm

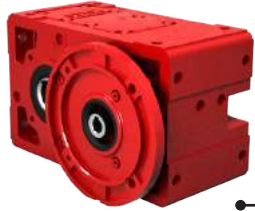

**PARALEL MİLLİ
MOTORLU REDÜKTÖR**
PARALLEL SHAFT
GEARBOXES WITH MOTOR

Gövde Büyüküğü Size	Nominal Çıkış Momenti Rated Output Torque
063	300 Nm
080	650 Nm
100	1.400 Nm
125	2.750 Nm
140	4.200 Nm
160	6.000 Nm
180	7.500 Nm
200	12.000 Nm
225	18.000 Nm
250	26.550 Nm
280	30.000 Nm
320	45.000 Nm
360	70.000 Nm



**KONİK HELİSEL DİŞLİ
MOTORLU REDÜKTÖR**
BEVEL HELICAL - RIGHTANGLE
GEARBOXES WITH MOTOR

Gövde Büyüküğü Size	Nominal Çıkış Momenti Rated Output Torque
063	300 Nm
080	650 Nm
100	1.400 Nm
125	2.750 Nm
140	4.200 Nm
160	6.000 Nm
180	7.500 Nm
200	12.000 Nm
225	18.000 Nm
250	26.550 Nm
280	30.000 Nm
320	45.000 Nm
360	70.000 Nm



**PARALEL MİLLİ
EKSTRUDER REDÜKTÖR**
PARALLEL SHAFT
EXTRUDER GEARBOX

Gövde Büyüküğü Size	Nominal Çıkış Momenti Rated Output Torque
140	4.200 Nm
160	6.000 Nm
180	7.500 Nm
200	12.000 Nm
225	18.000 Nm
250	26.550 Nm
280	30.000 Nm
320	45.000 Nm
360	70.000 Nm



**PARALEL MİLLİ
EKSTRUDER REDÜKTÖR
(UZUN DİZAYN)**
PARALLEL SHAFT
EXTRUDER GEARBOX
(LONG DESIGN)

Gövde Büyüküğü Size	Nominal Çıkış Momenti Rated Output Torque
160	6.000 Nm
180	7.500 Nm
200	12.000 Nm
225	18.000 Nm
250	26.550 Nm

ZET

R e d ü k t ö r

ZET Redüktör Sanayi ve Ticaret A.Ş.



İSTANBUL MERKEZ OFİS / HEAD OFFICE

Uzunçayır Caddesi No: 43
D Blok No:3-4
34722 - Hasanpaşa
İstanbul - Türkiye

Tel : +90-216-327 7254 (2L pbx)
: +90-216-326 0679
Fax : +90-216-326 0078

ESKİŞEHİR FABRİKA / FACTORY

Organize Sanayi Bölgesi
14. Cadde No: 17
26110 - OSB
Eskişehir -Türkiye

Tel : +90-222-236 2017 (4L pbx)
Fax : +90-222-236 2035

info@hydrozet.com
www.hydrozet.com
www.zetreduktor.com