

VIBRATION MOTOR CATALOGUE

2017



55
YIL

MERKEZ

Eseñehir Mah. Kmr Sok. No:15
34776 mraniye / İstanbul
+90 216 364 4646

www.salter.com.tr

ŐUBE

Metal İŐ Sanayi Sitesi 12. Blok No:7/9
34490 İkitelli / İstanbul
+90 212 671 47 97

info@salter.com.tr

İZMİR

Tuna Mah. Sanat Cad. No:17/C
Seluklu İŐ Merkezi amdibi
35090 Bornova / İzmir
+90 232 459 2215

www.izmirsalter.com

PRODUCT RANGE



THREEPHASE FOOT-MOUNTED VIBRATION MOTORS



SINGLEPHASE FOOT-MOUNTED VIBRATION MOTORS



VIBRATION MOTORS WITH DC/AC CONVERTER



MICRO VIBRATION MOTORS



FLANGED VIBRATION MOTORS

About Us

Miksan Motor Sanayi ve Ticaret A.Ş. is founded in Hasköy, Istanbul in 1977 to producing 71 frame squirrel cage electric motors.

In 1982, Miksan Motor began manufacturing immersion pump to meet domestic markets demand. In 2003, we extend our product range with vibration motors. Our company produce vibration motor that is suitable for todays technology and quality.

Casing of our vibration motor is high alloyed aluminium from VA series to VE series. For the casing of vibration motors that have higher centrifugal force (from VE series to VL series) is nodular cast iron (GGG50).



Currently, Miksan Motor manufactures electrical vibration motors from 0,2 kN to 90,2 kN at 2-4-6-8 pole in Beylikduzu/Istanbul. Miksan Motor's vibration motors are designed and manufactured using the latest technologies and premium quality materials.

Our products meet all the requirements of the related IEC, DIN and TSE standards. In addition, we have "ATEX II 2 D Ex tb IIIC (T 120 °C) Db , IP 66 " certificate for our foot-mounted vibration motors.

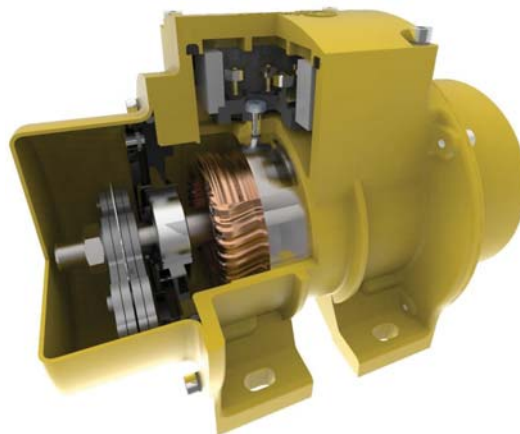

THREE-PHASE FOOT MOUNTED VIBRATION MOTORS



Foot-mounted vibration motors that have maximum 9197 kgf (90,2 kN) centrifugal force are suitable for vibration machine manufacturer and other sectors in industry.

Miksan Motor's threephase foot-mounted vibration motors can operate in all conditions and environments with high performance. Also, these series have ATEX certification for Zone 21 and 22.

TECHNICAL SPECIFICATIONS

Power Supply

Power supply of vibration motors is 230 Δ /400 Y Volt and 50-60 Hz as a standart. Please contact us for the special voltage and frequency rate.

Electric Motor

Electric motor of vibration motors has higher starting torque than threephase asynchronous electric motor. Over heating problem of the vibration motor due to no vantilation system is taking into consideration at designing.

Polarity

As a standart vibration motors are manufactured in 2, 4, 6 and 8 pole.

Motor Shaft

Motor shaft of vibration motors is produced from C45 structural steel.

Rotor

Rotor is produced with injecting high alloyed alluminium to the channel of the packed siliceous sheet metal.

Bearings

The series with lower centrifugal force (from VA to VC series) are equipped with deep groove ball bearing (2Z) with C3 internal clearance. The series with higher centrifugal force (from VD to VL series) are equipped with cylindrical roller bearings (NJ Series) with C4 internal clearance. All of the bearings, that we are using, are suitable to operate at heavy duty conditions.



Category: II 2 D

Degree of Protection: tD A21 IP66

Temperature Class: 120 °C

ATEX Certificate: ATEX II 2D Extb IIIC (T 120 °C) Db

Useable zone: Zone 21 and 22

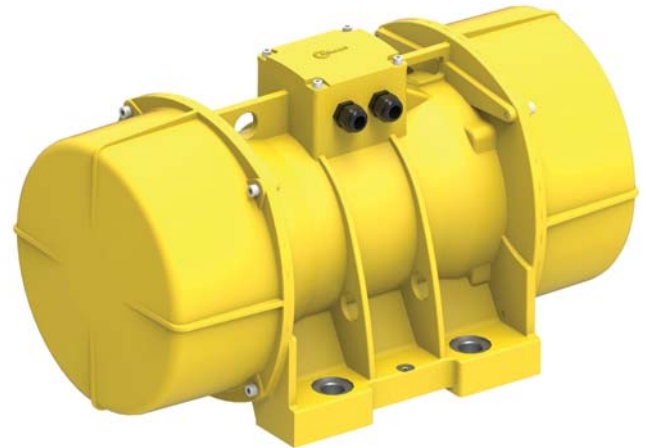

Eccentric Weights

The weights can adjust easily by rotating or subtracting according to the type of the vibration motors.

Casing

Casing of vibration motor is high alloyed aluminium from VA series to VE series. For the casing of vibration motors that have higher centrifugal force (from VE series to VL series) is nodular cast iron (GGG 50).

Eccentric Weights Cover

The eccentric weights cover is sheet metal up to VK series. VK and VL series have aluminium weight covers. The purpose of the eccentric weight covers are protecting the eccentric weights from the external factors and providing the safety.

Insulation Class

Insulation class of our standart range vibration motor is F class (155 °C).

Degree of Protection

Degree of protection is IP 66.

Lubrication

Except the vibration motors that used self-lubricated bearings (deep groove ball bearings - 2Z), bearings of the vibration motors (NJ series) are lubricated in our factory. Apart from this, bearings have to be lubricated with the aid of grease nipple that is on the vibration motor case during the maintance. Required grease amount is written in the " Vibration Motor User's Manual.

Painting

Vibration motors are painted with RAL 1003 paint by using electrostatic painting method.

2 POLE

50 Hz-3000 rpm ~ 60 Hz-3600 rpm



*Please contact us for 60 Hz values.

MECHANICAL SPECIFICATIONS						ELECTRICAL SPECIFICATIONS		
RPM	TYPE	Centrifugal Force		Static Moment	Weight	Nominal Voltage	Max. Current	Max. Input Power
50 Hz		KG	N	kgmm	KG	V	A	kW
3000	VA 2-80	80	785	8	6,2	230/400	0,60/0,35	0,17
	VA 2-120	120	1177	12	6,6	230/400	0,60/0,35	0,17
	VA 2-200	200	1962	20	7,0	230/400	0,60/0,35	0,17
	VB 2-350	340	3335	34	10,2	230/400	0,87/0,50	0,22
	VC 2-500	500	4905	50	14,5	230/400	1,55/0,90	0,44
	VC 2-700	700	6867	70	15,5	230/400	1,55/0,90	0,44
	VD 2-750	790	7750	78	21,3	230/400	1,90/1,10	0,69
	VD 2-1100	1048	10281	104	22,3	230/400	2,34/1,35	0,75
	VE 2-1500	1480	14519	147	51,3	230/400	5,20/3,00	1,3
	VE 2-1800	1770	17364	176	52,0	230/400	5,20/3,00	1,3
	VE 2-2400	2360	23152	234	54,0	230/400	6,00/3,50	1,6
	VG 2-3000	2960	29038	294	70,0	230/400	8,70/5,00	3,0
	VG 2-3800	3745	36738	372	72,0	230/400	8,70/5,00	3,0
	VH 2-4800	4800	47088	477	91,0	230/400	13,10/7,60	5,0
	VL 2-6000	5994	58801	596	184,0	400/690	10,00/5,75	5,5
	VL 2-7500	7415	72741	737	187,0	400/690	17,00/9,80	10,0
VL 2-9000	8900	87309	885	190,0	400/690	17,00/9,80	10,0	

Working Moment = 2 x Static Moment

*We reserve the right to modify the specifications and dimensions without notice.

Figure 1

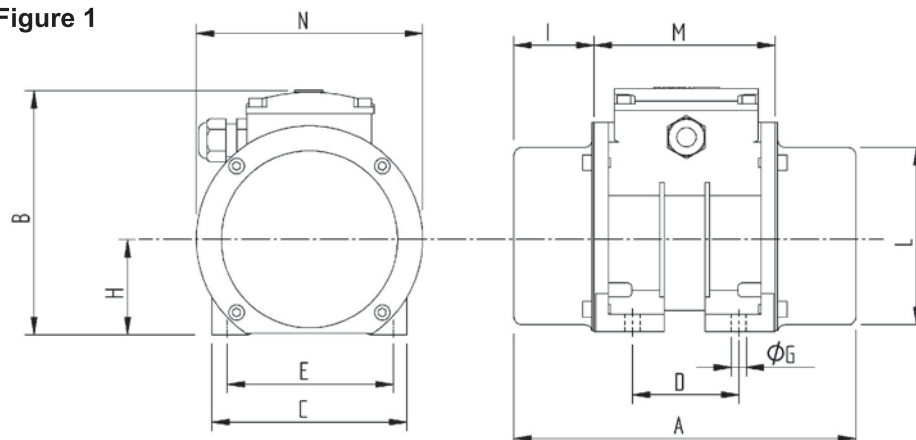

DIMENSIONS (mm)

TYPE	A	B	C	D	E	ØGx4	H	I	L	M	N	Cable Entry	Fig. No
VA 2-80	219	156	125	74-62	106	9	62	51,5	113	116	145	M20 x 1,5	1
VA 2-120	219	156	125	74-62	106	9	62	51,5	113	116	145	M20 x 1,5	1
VA 2-200	219	156	125	74-62	106	9	62	51,5	113	116	145	M20 x 1,5	1
VB 2-350	285	175	152	90	125	13	75	66,5	130	152	162	M20 x 1,5	1
VC 2-500	260	196	172	95-105	140	13	86	54	151	152	191	M20 x 1,5	1
VC 2-700	260	196	172	95-105	140	13	86	54	151	152	191	M20 x 1,5	1
VD 2-750	368	232	210	120	170	17	109	89	188	190	230	M20 x 1,5	1
VD 2-1100	368	232	210	120	170	17	109	89	188	190	230	M20 x 1,5	1
VE 2-1500	428	253	235	140	190	17	116	85	212	259	274	M20 x 1,5	2
VE 2-1800	428	253	235	140	190	17	116	85	212	259	274	M20 x 1,5	2
VE 2-2400	428	253	235	140	190	17	116	85	212	259	274	M20 x 1,5	2
VG 2-3000	522	277	270	155	225	22	130	116	238	290	294	M20 x 1,5	2
VG 2-3800	522	277	270	155	225	22	130	116	238	290	294	M20 x 1,5	2
VH 2-4800	548	334	310	155	255	23,5	160	119	292	310	330	M25 x 1,5	2
VL 2-6000	692	400	390	200	320	28	195	163	383	365	384	M25 x 1,5	2
VL 2-7500	692	400	390	200	320	28	195	163	383	365	384	M25 x 1,5	2
VL 2-9000	692	400	390	200	320	28	195	163	383	365	384	M25 x 1,5	2

Figure 2

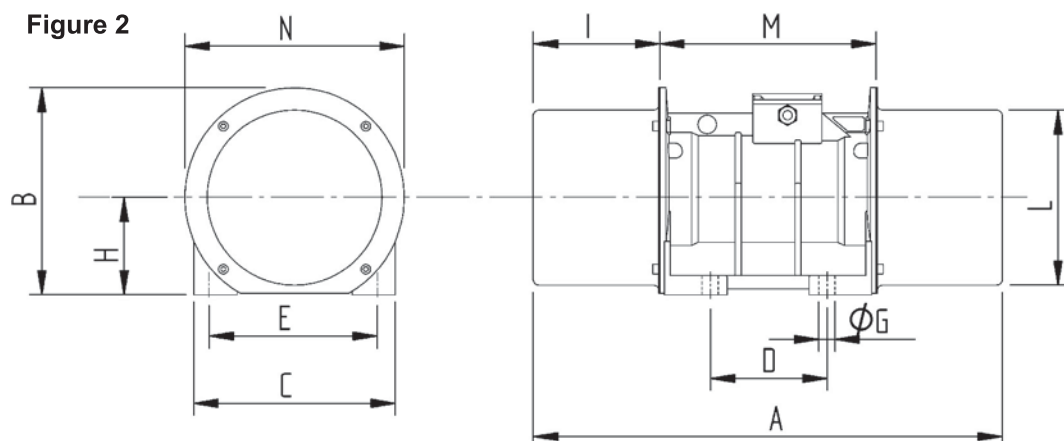

4 POLE

50 Hz-1500 rpm ~ 60 Hz-1800 rpm



*Please contact us for 60 Hz values.

MECHANICAL SPECIFICATIONS						ELECTRICAL SPECIFICATIONS		
RPM	TYPE	Centrifugal Force		Static Moment	Weight	Nominal Voltage	Max. Current	Max. Input Power
50 Hz		KG	N	kgmm	KG	V	A	Kw
1500	VA 4-50	50	491	20	6,9	230/400	0,52/0,30	0,15
	VA 4-80	80	785	32	7,6	230/400	0,52/0,30	0,15
	VB 4-200	210	2060	84	12,1	230/400	0,72/0,42	0,17
	VC 4-400	400	3924	159	19,0	230/400	1,30/0,75	0,35
	VC 4-600	570	5592	227	20,1	230/400	1,30/0,75	0,35
	VD 4-750	750	7358	298	30,0	230/400	1,73/1,00	0,6
	VD 4-1100	1100	10791	437	33,0	230/400	2,16/1,25	0,7
	VE 4-1500	1480	14519	588	62,0	230/400	4,33/2,50	1,25
	VE 4-1800	1740	17069	692	64,5	230/400	4,76/2,75	1,25
	VE 4-2100	2080	20405	827	67,5	230/400	4,76/2,75	1,4
	VG 4-2600	2560	25113	1018	82,0	230/400	5,71/3,30	1,6
	VG 4-3200	3290	32275	1308	88,0	230/400	6,58/3,80	1,9
	VH 4-4000	3981	39053	1583	103,0	230/400	6,75/3,90	2,1
	VH 4-4500	4584	44969	1823	108,0	230/400	8,31/4,80	2,4
	VK 4-5000	5000	49050	1988	144,0	230/400	10,65/6,15	3,6
	VK 4-6000	6000	58860	2386	151,0	230/400	10,65/6,15	3,6
VL 4-7500	7423	72820	2951	197,0	400/690	13,00/7,50	7,0	
VL 4-9000	9197	90223	3657	206,0	400/690	13,00/7,50	7,0	

Working Moment = 2 x Static Moment

*We reserve the right to modify the specifications and dimensions without notice.

Figure 1

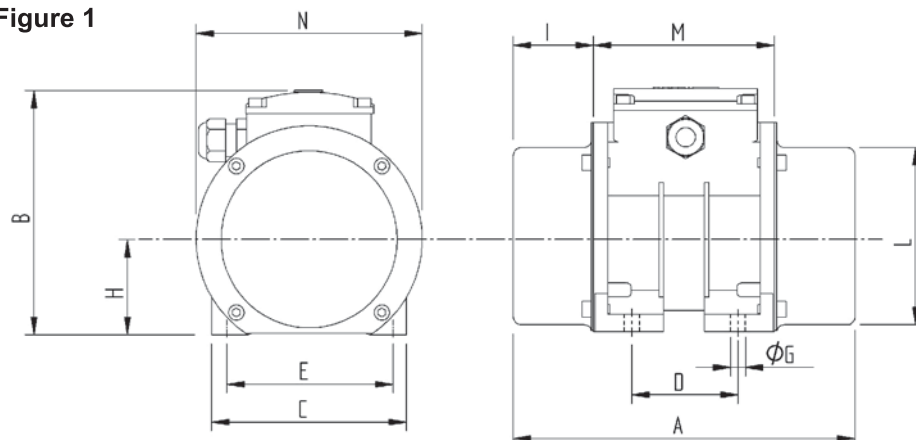

DIMENSIONS (mm)													
TYPE	A	B	C	D	E	ØGx4	H	I	L	M	N	Cable Entry	Fig. No
VA 4-50	219	156	125	74-62	106	9	62	51,5	113	116	145	M20 x 1,5	1
VA 4-80	219	156	125	74-62	106	9	62	51,5	113	116	145	M20 x 1,5	1
VB 4-200	285	175	152	90	125	13	75	66,5	130	152	162	M20 x 1,5	1
VC 4-400	306	196	172	95-105	140	13	86	77	151	152	191	M20 x 1,5	1
VC 4-600	331	196	172	95-105	140	13	86	89,5	151	152	191	M20 x 1,5	1
VD 4-750	368	235	210	120	170	17	109	89	188	190	230	M20 x 1,5	1
VD 4-1100	416	235	210	120	170	17	109	113	188	190	230	M20 x 1,5	1
VE 4-1500	520	253	235	140	190	17	116	131	212	259	274	M20 x 1,5	2
VE 4-1800	520	253	235	140	190	17	116	131	212	259	274	M20 x 1,5	2
VE 4-2100	520	253	235	140	190	17	116	131	212	259	274	M20 x 1,5	2
VG 4-2600	522	277	270	155	225	22	130	116	234	290	294	M20 x 1,5	2
VG 4-3200	628	277	270	155	225	22	130	169	234	290	294	M20 x 1,5	2
VH 4-4000	548	334	310	155	255	23,5	160	119	292	310	330	M25 x 1,5	2
VH 4-4500	604	334	310	155	255	23,5	160	147	292	310	330	M25 x 1,5	2
VK 4-5000	612	356	340	180	280	26	170	140,5	310	330	327	M25 x 1,5	2
VK 4-6000	612	356	340	180	280	26	170	140,5	310	330	327	M25 x 1,5	2
VL 4-7500	692	400	390	200	320	28	195	163	383	365	384	M25 x 1,5	2
VL 4-9000	692	400	390	200	320	28	195	163	383	365	384	M25 x 1,5	2

Figure 2

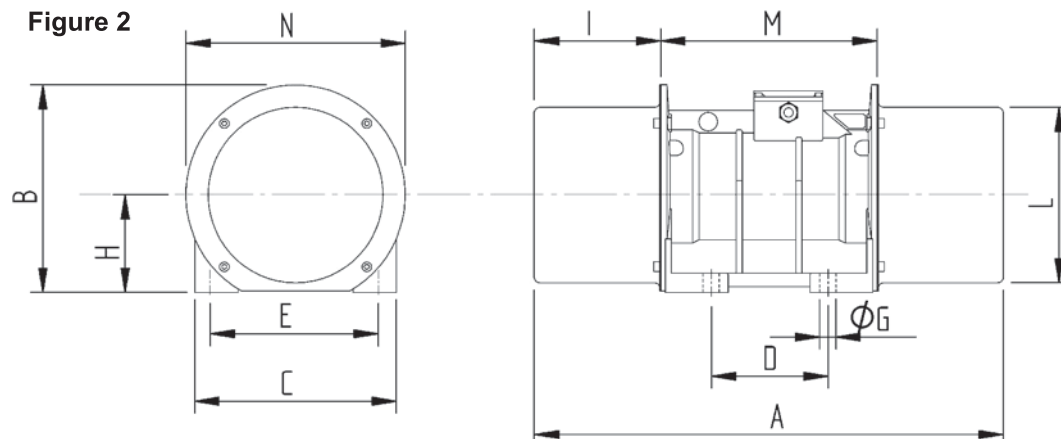

6 POLE

50 Hz-1000 rpm ~ 60 Hz-1200 rpm



*Please contact us for 60 Hz values.

MECHANICAL SPECIFICATIONS					ELECTRICAL SPECIFICATIONS			
RPM	TYPE	Centrifugal Force		Static Moment	Weight	Nominal Voltage	Max. Current	Max. Input Power
50 Hz		KG	N	kgmm	KG	V	A	Kw
1000	VC 6-180	180	1766	161	17,7	230/400	1,12/0,65	0,3
	VC 6-250	250	2453	224	20,0	230/400	1,12/0,65	0,3
	VD 6-340	340	3335	304	30,0	230/400	1,38/0,80	0,43
	VD 6-500	500	4905	447	35,0	230/400	1,55/0,90	0,43
	VE 6-800	792	7770	709	62,0	230/400	2,95/1,70	0,65
	VE 6-1000	950	9320	850	64,5	230/400	3,63/2,10	0,75
	VE 6-1400	1350	13243	1208	73,0	230/400	3,81/2,20	0,9
	VG 6-1700	1660	16284	1485	91,0	230/400	4,15/2,40	1,1
	VG 6-2200	2190	21483	1959	98,0	230/400	4,84/2,80	1,4
	VH 6-2700	2683	26320	2400	119,0	230/400	7,10/4,10	1,95
	VH 6-3200	3175	31146	2840	126,0	230/400	8,31/4,80	2,1
	VK 6-3800	3800	37278	3399	174,0	230/400	12,30/7,10	3,2
	VK 6-4700	4700	46107	4204	186,0	230/400	12,30/7,10	3,2
	VK 6-5200	5200	51012	4652	193,0	230/400	12,30/7,10	3,2
	VL 6-6500	6598	64726	5902	260,0	400/690	14,00/8,00	7,5
	VL 6-8000	8175	80197	7313	277,0	400/690	14,00/8,00	7,5
VL 6-9000	8798	86308	7870	293,0	400/690	14,00/8,00	7,5	

Working Moment = 2 x Static Moment

*We reserve the right to modify the specifications and dimensions without notice.

Figure 1

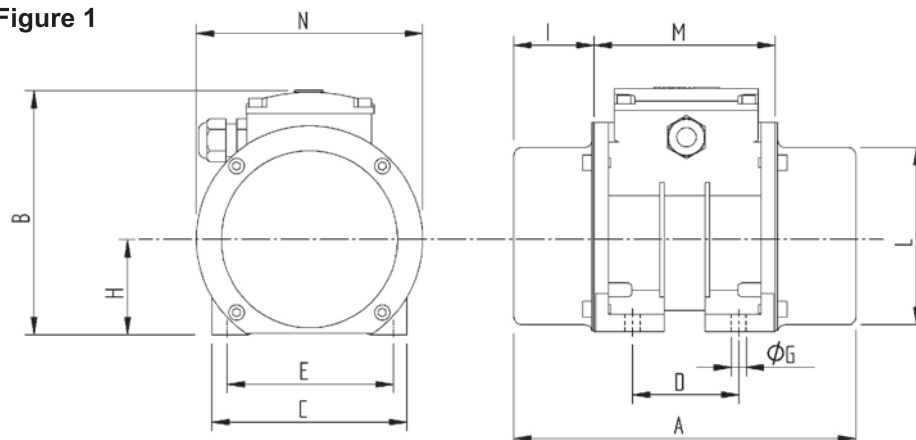

DIMENSIONS (mm)													
TYPE	A	B	C	D	E	ØGx4	H	I	L	M	N	Cable Entry	Fig. No
VC 6-180	306	196	172	95-105	140	13	86	77	151	152	191	M20 x 1,5	1
VC 6-250	331	196	172	95-105	140	13	86	89,5	151	152	191	M20 x 1,5	1
VD 6-340	368	235	210	120	170	17	109	89	188	190	230	M20 x 1,5	1
VD 6-500	416	235	210	120	170	17	109	113	188	190	230	M20 x 1,5	1
VE 6-800	520	253	235	140	190	17	116	131	212	259	274	M20 x 1,5	2
VE 6-1000	520	253	235	140	190	17	116	131	212	259	274	M20 x 1,5	2
VE 6-1400	578	253	235	140	190	17	116	160	212	259	274	M20 x 1,5	2
VG 6-1700	628	277	270	155	225	22	130	169	234	290	294	M20 x 1,5	2
VG 6-2200	628	277	270	155	225	22	130	169	234	290	294	M20 x 1,5	2
VH 6-2700	604	334	310	155	255	23,5	160	147	292	310	330	M25 x 1,5	2
VH 6-3200	644	334	310	155	255	23,5	160	167	292	310	330	M25 x 1,5	2
VK 6-3800	702	355	340	180	280	26	170	186	310	330	327	M25 x 1,5	2
VK 6-4700	792	355	340	180	280	26	170	231	310	330	327	M25 x 1,5	2
VK 6-5200	792	355	340	180	280	26	170	231	310	330	327	M25 x 1,5	2
VL 6-6500	832	400	390	200	320	28	195	233	383	365	384	M25 x 1,5	2
VL 6-8000	832	400	390	200	320	28	195	233	383	365	384	M25 x 1,5	2
VL 6-9000	832	400	390	200	320	28	195	233	383	365	384	M25 x 1,5	2

Figure 2

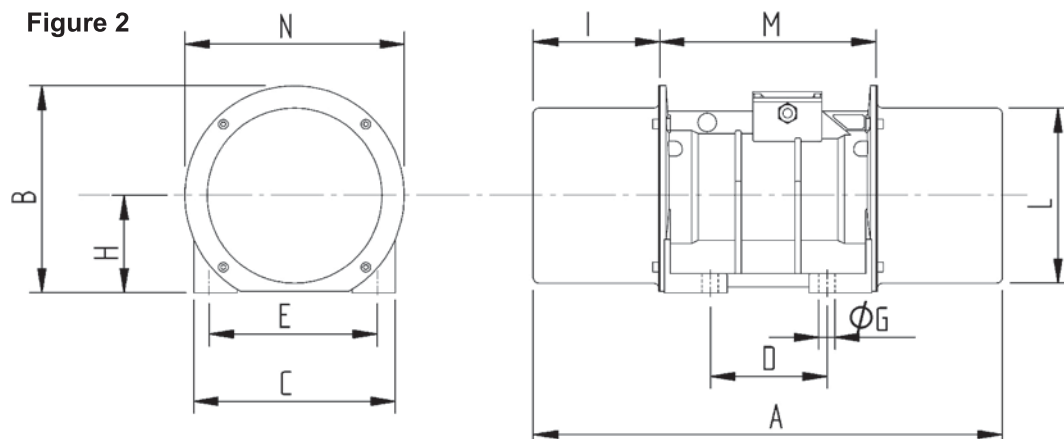

8 POLE

50 Hz-750 rpm ~ 60 Hz-900 rpm



*Please contact us for 60 Hz values.

MECHANICAL SPECIFICATIONS						ELECTRICAL SPECIFICATIONS		
RPM	TYPE	Centrifugal Force		Static Moment	Weight	Nominal Voltage	Max. Current	Max. Input Power
50 Hz		KG	N	kgmm	KG	V	A	Kw
750	VD 8-200	195	1913	310	28,0	230/400	1,38/0,80	0,43
	VD 8-300	290	2845	461	33,0	230/400	1,55/0,90	0,43
	VE 8-520	510	5003	811	64,5	230/400	2,68/1,55	0,5
	VE 8-780	765	7505	1217	73,0	230/400	2,77/1,60	0,55
	VG 8-1000	1000	9810	1590	92,0	230/400	3,98/2,30	0,95
	VG 8-1200	1200	11772	1908	99,0	230/400	4,67/2,70	1,1
	VH 8-1500	1500	14715	2386	119,0	230/400	6,92/4,00	1,5
	VK 8-2200	2200	21582	3499	174,0	230/400	12,30/7,10	2,5
	VK 8-2650	2650	25997	4214	184,0	230/400	12,30/7,10	2,5
	VL 8-3700	3711	36405	5902	260,0	400/690	11,00/6,35	5,0
VL 8-4500	4598	45106	7313	277,0	400/690	11,00/6,35	5,0	

Working Moment = 2 x Static Moment

Figure 1

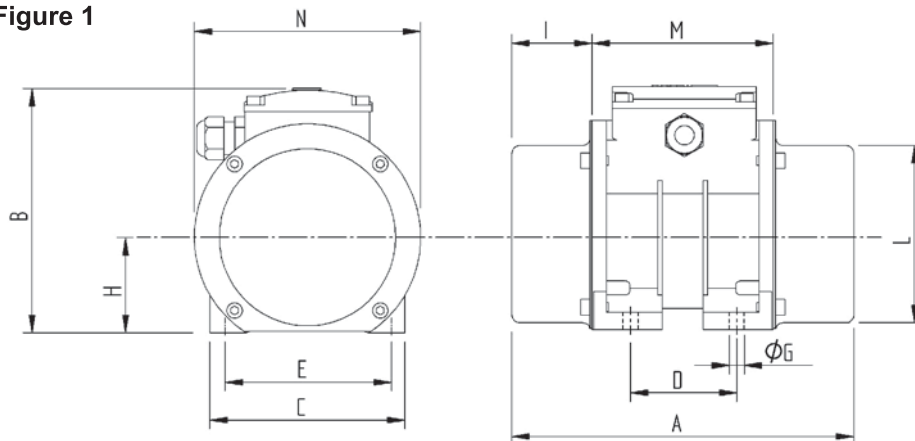

DIMENSIONS (mm)													
TYPE	A	B	C	D	E	ØGx4	H	I	L	M	N	Cable Entry	Fig. No
VD 8-200	368	235	210	120	170	17	109	89	188	190	230	M20 x 1,5	1
VD 8-300	416	235	210	120	170	17	109	113	188	190	230	M20 x 1,5	1
VE 8-520	520	253	235	140	190	17	116	131	212	259	274	M20 x 1,5	2
VE 8-780	578	253	235	140	190	17	116	160	212	259	274	M20 x 1,5	2
VG 8-1000	628	277	270	155	225	22	130	169	234	290	294	M20 x 1,5	2
VG 8-1200	628	277	270	155	225	22	130	169	234	290	294	M20 x 1,5	2
VH 8-1500	604	335	310	155	255	23,5	160	147	290	310	333	M25 x 1,5	2
VK 8-2200	702	355	340	180	280	26	170	186	310	330	327	M25 x 1,5	2
VK 8-2650	702	355	340	180	280	26	170	186	310	330	327	M25 x 1,5	2
VL 8-3700	832	400	390	200	320	28	195	233	383	365	384	M25 x 1,5	2
VL 8-4500	832	400	390	200	320	28	195	233	383	365	384	M25 x 1,5	2

Figure 2

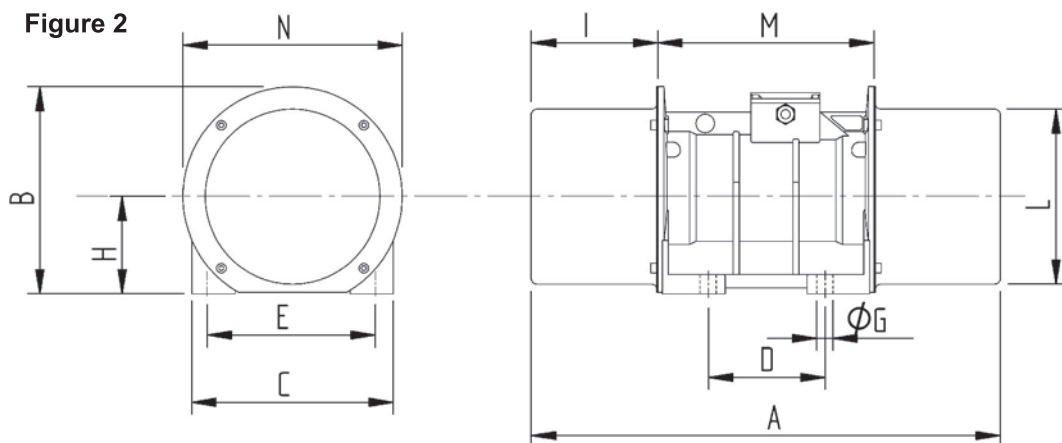

SINGLE-PHASE FOOT MOUNTED VIBRATION MOTORS



Singlephase foot-mounted vibration motors that have maximum 500 kgf (4,9 kN) centrifugal force are suitable for vibration machine manufacturer and other sectors in industry.

Miksan Motor's singlephase foot-mounted vibration motors can operate in all conditions and environments with high performance.

TECHNICAL SPECIFICATIONS

Power Supply

Power supply of vibration motors is 230 Volt and 50-60 Hz as standart. Please contact us for the special voltage and frequency rate.

Electric Motor

Electric motor of singlephase vibration motors has higher starting torque than singlephase asynchronous electric motor. Standart Miksan Motor singlephase vibration motors have permanent split capacitor. Over heating problem of the vibration motor due to no vantilation system is taking into consideration at designing.

Polarity

Standart vibration motors are manufactured in 2 or 4 pole.

Motor Shaft

Motor shaft of vibration motors is produced from C45 structural steel.

Rotor

Rotor is produced by injecting high alloyed alluminium to the channel of the packed siliceous sheet metal.

Bearings

The singlephase vibration motors are equipped with deep groove ball bearing (2Z) with C3 internal clearance.



Eccentric Weights

The weights can adjust easily by rotating or subtracting according to the type of the vibration motors.

Casing

Casing of vibration motor is high alloyed aluminium.

Eccentric Weights Cover

The eccentric weights cover of single phase vibration motor is sheet metal. The purpose of the eccentric weight covers are protecting the eccentric weights from the external factors and providing the safety.

Insulation Class

Insulation class of our standart range vibrtion motor is F class (155 °C).

Degree of Protection

Degree of protection is IP 66.

Lubrication

Our singlephase vibration motors are equipped with self-lubricated bearings (deep groove ball bearings) so, lubrication is not necessary.

Painting

Vibration motors are painted with RAL 1003 paint by using electrostatic painting method.

2 POLE

50 Hz-3000 rpm ~ 60 Hz-3600 rpm



*Please contact us for 60 Hz values.

MECHANICAL SPECIFICATIONS						ELECTRICAL SPECIFICATIONS			
RPM	TYPE	Centrifugal Force		Static Moment	Weight	Nominal Voltage	Max. Current	Capacitor	Max. Input Power
50 Hz		KG	N	kgmm	KG	V	A	µF	kW
3000	VA 2-80 M	80	785	8	6,2	230	0,3	6	0,1
	VA 2-120 M	120	1177	12	6,6	230	0,35	8	0,1
	VA 2-200 M	200	1962	20	7,0	230	1,0	6	0,15
	VB 2-350 M	340	3335	34	10,2	230	1,5	8	0,16
	VC 2-500 M	500	4905	50	14,5	230	1,1	8	0,17

DIMENSIONS (mm)													
TYPE	A	B	C	D	E	ØGx4	H	I	L	M	N	Cable Entry	Fig. No
VA 2-80 M	219	156	125	74-62	106	9	62	51,5	113	116	145	M20 x 1,5	1
VA 2-120 M	219	156	125	74-62	106	9	62	51,5	113	116	145	M20 x 1,5	1
VA 2-200 M	219	156	125	74-62	106	9	62	51,5	113	116	145	M20 x 1,5	1
VB 2-350 M	285	175	152	90	125	13	75	66,5	130	152	162	M20 x 1,5	1
VC 2-500 M	260	196	172	95-105	140	13	86	54	151	152	191	M20 x 1,5	1

Working Moment = 2 x Static Moment

Figure 1

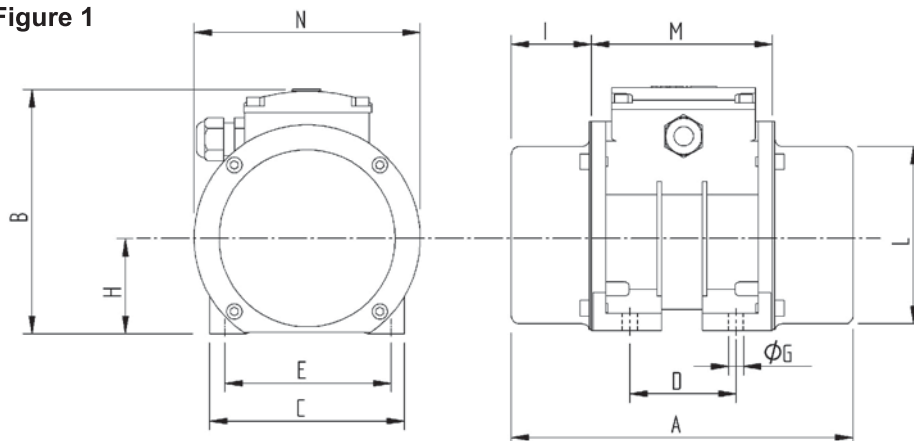

*We reserve the right to modify the specifications and dimensions without notice.

4 POLE

50 Hz-1500 rpm ~ 60 Hz-1800 rpm



*Please contact us for 60 Hz values.

MECHANICAL SPECIFICATIONS						ELECTRICAL SPECIFICATIONS			
RPM	TYPE	Centrifugal Force		Static Moment	Weight	Nominal Voltage	Max. Current	Capacitor	Max. Input Power
50 Hz		KG	N	kgmm	KG	V	A	µF	kW
1500	VA 4-30 M	30	295	12	6,5	230	0,6	3,5	0,1
	VA 4-50 M	50	491	20	6,9	230	0,6	4,5	0,1
	VA 4-80 M	80	785	32	7,6	230	0,65	8	0,15
	VB 4-200 M	210	2060	84	12,1	230	2,0	8	0,42

DIMENSIONS (mm)													
TYPE	A	B	C	D	E	ØGx4	H	I	L	M	N	Cable Entry	Fig. No
VA 4-30 M	219	153	125	74-62	106	9	62	51,5	113	116	145	M20 x 1,5	1
VA 4-50 M	219	153	125	74-62	106	9	62	51,5	113	116	145	M20 x 1,5	1
VA 4-80 M	219	172	152	74-62	106	9	62	51,5	113	116	145	M20 x 1,5	1
VB 4-200 M	285	172	172	90	125	13	75	66,5	130	152	162	M20 x 1,5	1

Working Moment = 2 x Static Moment

Figure 1

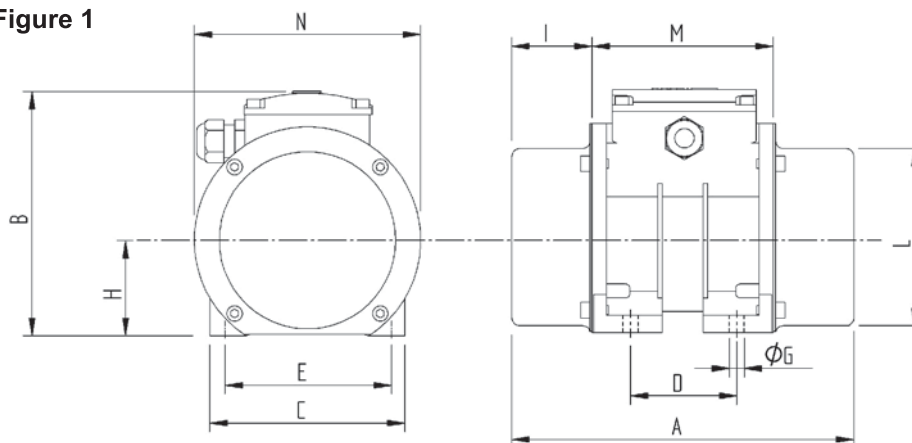

*We reserve the right to modify the specifications and dimensions without notice.

VIBRATION MOTORS WITH DC/AC CONVERTER



Vibration motors with DC/AC converter that have maximum 200 kgf (1,96 kN) centrifugal force are suitable for vibration machine manufacturer and other sectors in industry.

Miksan Motor's vibration motors with DC/AC converter can operate in all conditions and environments with high performance.

TECHNICAL SPECIFICATIONS

Power Supply

Power supply of vibration motors with DC/AC converter is 24 V DC. Please contact us for the special voltage and frequency rate.

Electric Motor

Electric motor of vibration motor with DC/AC converter has higher starting torque than standart asynchronous electric motor. The electric motor of the vibration motor is fed by converter. Over heating problem of the vibration motor due to no vantilation system is taking into consideration at designing.

Polarity

As a standart vibration motors are manufactured in 2 or 4 pole.

Motor Shaft

Motor shaft of vibration motors is produced from C45 structural steel.

Rotor

Rotor is produced by injecting high alloyed alluminium to the channel of the packed siliceous sheet metal.

Bearings

The vibration motors with DC/AC converter are equipped with deep groove ball bearing (2Z) with C3 internal clearance.

Eccentric Weights

The weights can adjust easily by rotating or subtracting according to the type of the vibration motors.

2-4 POLE

50 Hz-3000 rpm ~ 60 Hz-3600 rpm
50 Hz-1500 rpm ~ 60 Hz-1800 rpm

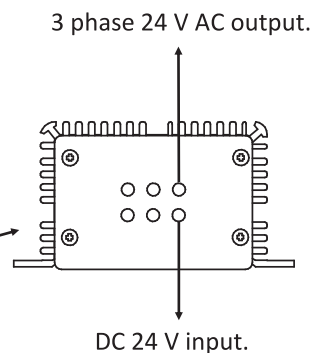

*Please contact us for 60 Hz values.

MECHANICAL SPECIFICATIONS						ELECTRICAL SPECIFICATIONS			CONVERTER SPECIFICATIONS		
RPM	TYPE	Centrifugal Force		Static Moment	Weight	Nominal Voltage	Max. Current	Max. Input Power	Nominal Voltage (DC)	Max. Current	Max. Input Power
50 Hz		KG	N	kgmm	KG	V	A	kW	V	A	kW
3000	VA 2-120 DC	120	1177	12	6,6	24	3,75	0,18	24	9,5	0,24
	VA 2-200 DC	200	1962	20	7,0	24	4,0	0,18	24	9,5	0,24
1500	VA 4-50 DC	50	491	20	6,9	24	3,5	0,12	24	9,5	0,24
	VA 4-80 DC	80	785	32	7,6	24	3,75	0,12	24	9,5	0,24

Working Moment = 2 x Static Moment

DIMENSIONS (mm)													
TYPE	A	B	C	D	E	ØGx4	H	I	L	M	N	Cable Entry	Fig. No
VA 2-120 DC	219	156	125	74-62	106	9	62	51,5	113	116	145	M20 x 1,5	1
VA 2-200 DC	219	156	125	74-62	106	9	62	51,5	113	116	145	M20 x 1,5	1
VA 4-50 DC	219	156	125	74-62	106	9	62	51,5	113	116	145	M20 x 1,5	1
VA 4-80 DC	219	156	125	74-62	106	9	62	51,5	113	116	145	M20 x 1,5	1

Figure 1

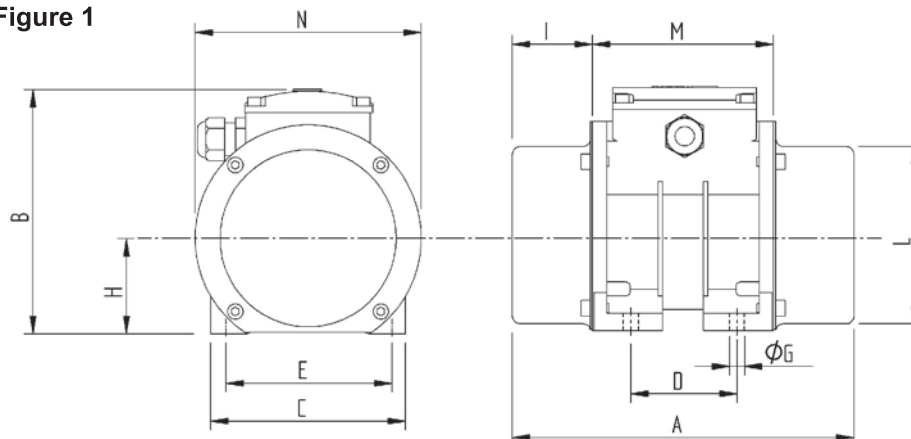

*We reserve the right to modify the specifications and dimensions without notice.

MICRO VIBRATION MOTORS



Category: II 3 D

Degree of Protection: tc IIIC (T 100 °C) Db, IP65

Temperature Class: 100 °C

ATEX Certificate: ATEX II 3D Extc IIIC (T 100 °C) Dc

Useable zone: Zone 22



Micro vibration motors that have maximum 60 kgf (0,58 kN) centrifugal force are suitable for vibration machine manufacturer and other sectors in industry.

Miksan Motor's micro vibration motors can operate in all conditions and environments with high performance.

TECHNICAL SPECIFICATIONS

Power Supply

Power supply of vibration motors is 230 Volt singlephase or 230 Δ/400 Y Volt threephase and 50-60 Hz as a standart. Please contact us for the special voltage and frequency rate.

Electric Motor

Electric motor of micro vibration motors has higher starting torque than standart asynchronous electric motor. Standart Miksan Motor singlephase micro vibration motors have permanent split capacitor. Over heating problem of the vibration motor due to no vantilation system is taking into consideration at designing.

Polarity

As a standart vibration motors are manufactured in 2 or 4 pole.

Motor Shaft

Motor shaft of vibration motors is produced from C45 structural steel.

Rotor

Rotor is produced by injecting high alloyed alluminium to the channel of the packed siliceous sheet metal.

Bearings

The micro vibration motors are equipped with deep groove ball bearing (2Z) with C3 internal clearance.

Eccentric Weights

The weights can adjust easily by rotating or subtracting according to the type of the vibration motors.

2-4 POLE

CE

50 Hz-3000 rpm ~ 60 Hz-3600 rpm
50 Hz-1500 rpm ~ 60 Hz-1800 rpm

*Please contact us for 60 Hz values.

	MECHANICAL SPECIFICATIONS					ELECTRICAL SPECIFICATIONS				
	RPM	TYPE	Centrifugal Force		Static Moment	Weight	Nominal Voltage	Maks. Current	Capacitor	Maks. Input Power
	50 Hz		KG	N	kgmm	KG	V	A	µF	W
threephase	3000	VX 20	21	206	2,10	1,6	400	0,11	-	21
		VY 40	39	383	3,88	2,6	400	0,18	-	40
		VY 60	59	579	5,86	2,7	400	0,18	-	40
	1500	VY 25	25	245	9,94	3,0	400	0,18	-	56
singlephase	3000	VX 20 M	21	206	2,10	1,6	230	0,12	1	25
		VY 40 M	39	383	3,88	2,7	230	0,24	4	50
		VY 60 M	59	579	5,86	2,8	230	0,24	4	50
	1500	VY 25 M	25	245	9,94	3,1	230	0,28	4	58

Working Moment = 2 x Static Moment

Figure M

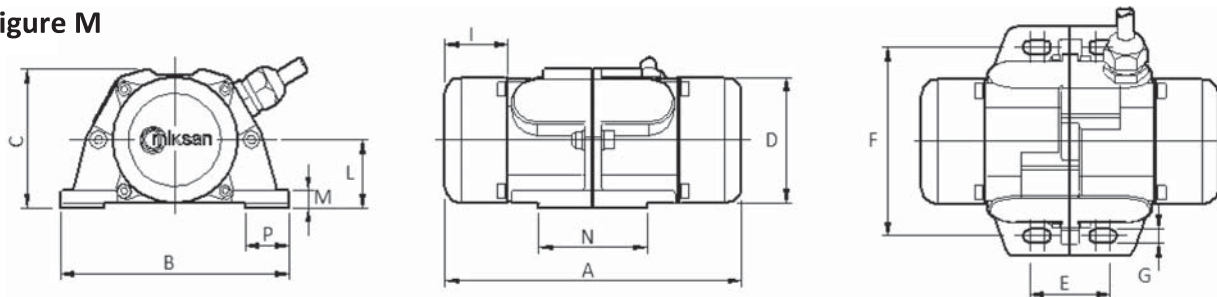
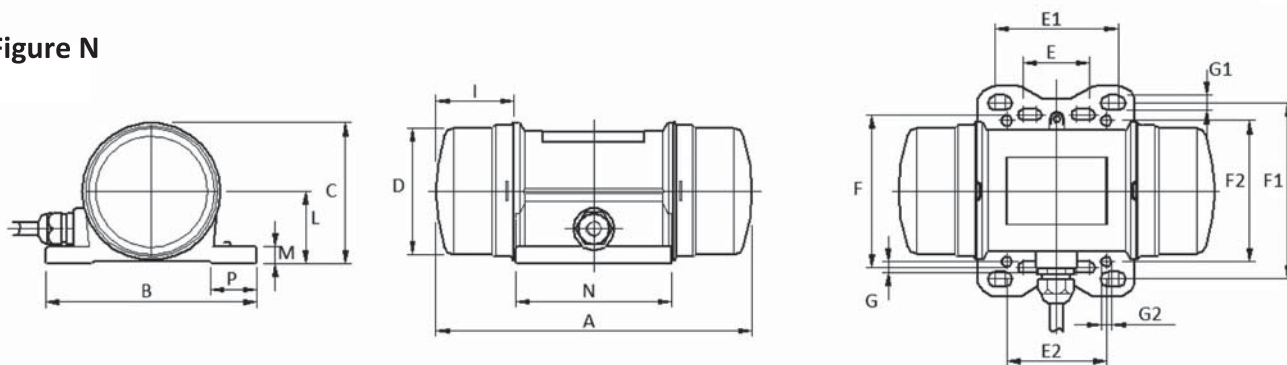

Figure N



*We reserve the right to modify the specifications and dimensions without notice.

	DIMENSIONS (mm)																			Cable Entry	Figure
	MODEL	A	B	C	D	E	E1	E2	F	F1	F2	G	G1	Ø G2	I	L	M	N	P		
threephase	VX 20	146	112	68	61	24 - 40	-	-	92	-	-	7	-	-	32	33	8,5	53	21	M16 x 1,5	M
	VY 40	190	127	85	77	24 - 40	62 - 74	60	92	106	85	9	6,5	6,5	47	43,5	10	94	28	M16 x 1,5	N
	VY 60	190	127	85	77	24 - 40	62 - 74	60	92	106	85	9	6,5	6,5	47	43,5	10	94	28	M16 x 1,5	N
	VY 25	190	127	85	77	24 - 40	62 - 74	60	92	106	85	9	6,5	6,5	47	43,5	10	94	28	M16 x 1,5	N
singlephase	VX 20 M	146	112	68	61	24 - 40	-	-	92	-	-	7	-	-	32	33	8,5	53	21	M16 x 1,5	M
	VY 40 M	190	127	85	77	24 - 40	62 - 74	60	92	106	85	9	6,5	6,5	47	43,5	10	94	28	M16 x 1,5	N
	VY 60 M	190	127	85	77	24 - 40	63 - 74	60	92	106	85	9	6,5	6,5	47	43,5	10	94	28	M16 x 1,5	N
	VY 25 M	190	127	85	77	24 - 40	64 - 74	60	92	106	85	9	6,5	6,5	47	43,5	10	94	28	M16 x 1,5	N

FLANGED VIBRATION MOTORS



Flanged vibration motors that have maximum 2080 kgf (20,4 kN) centrifugal force are suitable for vibration machine manufacturer and other sectors in industry.

Miksan Motor's flanged vibration motors can operate in all conditions and environments with high performance.

TECHNICAL SPECIFICATIONS

Power Supply

Power supply of vibration motors is 230 Volt singlephase or 230 Δ /400 Y Volt threephase and 50-60 Hz as a standart. Please contact us for the special voltage and frequency rate.

Electric Motor

Electric motor of flanged vibration motors has higher starting torque than standart asynchronous electric motor. Standart Miksan Motor singlephase flanged vibration motors have permanent split capacitor. Over heating problem of the vibration motor due to no vantilation system is taking into consideration at designing.

Polarity

As a standart vibration motors are manufactured in 2 or 4 pole.

Motor Shaft

Motor shaft of vibration motors is produced from C45 structural steel.

Rotor

Rotor is produced by injecting high alloyed alluminium to the channel of the packed siliceous sheet metal.

Bearings

The series with lower centrifugal force (from VYF to VCF series) are equipped with deep groove ball bearing (2Z) with C3 internal clearance. The series with higher centrifugal force (VDF and VEF series) are equipped with cylindrical roller bearings (NJ Series) with C4 internal clearance. All of the bearings, that we are using, are suitable to operate at heavy duty conditions.



Eccentric Weights

The weights can adjust easily by rotating or subtracting according to the type of the vibration motors.

Casing

Casing of vibration motor is high alloyed aluminium from VYF series to VEF series. For the casing of vibration motors that have higher centrifugal force (VEF series) is nodular cast iron (GGG 50).

Eccentric Weights Cover

The eccentric weights cover is sheet metal up to VK series. The purpose of the eccentric weight covers are protecting the eccentric weights from the external factors and providing the safety.

Insulation Class

Insulation class of our standart range vibrtion motor is F class (155 °C).

Degree of Protection

Degree of protection is IP 66.

Lubrication

Except the vibration motors that used self-lubricated bearings (deep groove ball bearings - 2Z), bearings of the vibration motors (NJ series) are lubricated in our factory. Apart from this, bearings have to be lubricated with the aid of grease nipple that is on the vibration motor case during the maintance. Required grease amount is written in the " Vibration Motor User's Manual.

Painting

Vibration motors are painted with RAL 1003 paint by using electrostatic painting method.

2 POLE CE

50 Hz-3000 rpm ~ 60 Hz-3600 rpm

*Please contact us for 60 Hz values.

MECHANICAL SPECIFICATIONS						ELECTRICAL SPECIFICATIONS			
RPM	TYPE	Centrifugal Force		Static Moment	Weight	Nominal Voltage	Max. Current	Capacitor	Max. Input Power
50 Hz		KG	N	kgmm	KG	V	A	µF	Kw
3000	VYF 2 - 60	59	579	5,86	2,8	400	0,18	-	0,04
	VAF 2 - 200	200	1962	20	6,9	230/400	0,60/0,35	-	0,17
	VBF 2 - 350	340	3335	34	10,0	230/400	0,87/0,50	-	0,22
	VCF 2 - 400	393	3860	39	13,1	230/400	1,55/0,90	-	0,44
	VCF 2 - 600	590	5790	59	13,7	230/400	1,55/0,90	-	0,44
	VDF 2 - 750	762	7475	76	21,6	230/400	1,90/1,10	-	0,69
	VDF 2 - 1100	1048	10281	104	22,6	230/400	2,34/1,35	-	0,75
	VEF 2 - 1500	1480	14519	147	51,3	230/400	5,20/3,00	-	1,3
VEF 2 - 1800	1770	17364	176	52,0	230/400	5,20/3,00	-	1,3	

3000	VYF 2 - 60 M	59	579	5,86	2,9	230	0,24	4	0,05
	VAF 2 - 200 M	200	1962	20	6,9	230	1,0	6	0,15
	VBF 2 - 350 M	340	3335	34	9,2	230	1,5	8	0,16
	VCF 2 - 400 M	393	3860	39	13,2	230	2,0	8	0,44
	VCF 2 - 600 M	590	5790	59	13,8	230	2,0	8	0,44

Working Moment = 2 x Static Moment

DIMENSIONS (mm)															
TYPE	A	B	C	D	H	E	F	G	I	L	M	N	O-Ring	Cable Entry	Figure
VYF 2-60	186	130	72	109	8,5 x 4	104	12	8	47	77	35	-	OR 3350	M16 x 1,5	B
VAF 2-200	215	211	102	188	12 x 4	140	15	10	51	113	23	-	OR 4650	M20 x 1,5	B
VBF 2-350	279	215	120	188	12 x 4	176	15	11	66	130	37	-	OR 4650	M20 x 1,5	B
VCF 2-400	240	235	144	205	12 x 6	122	10	13	46	151	70	160	OR 4700	M20 x 1,5	A
VCF 2-600	240	235	144	205	12 x 6	122	15	13	46	151	70	160	OR 4700	M20 x 1,5	A
VDF 2-750	350	280	144	230	15 x 6	189	20	15	89	188	71	185	OR 4800	M20 x 1,5	B
				254	14 x 4									M20 x 1,5	B
VDF 2-1100	350	280	144	230	15 x 6	189	27,5	15	89	188	71	185	OR 4800	M20 x 1,5	B
				254	14 x 4									M20 x 1,5	B
VEF 2-1500	421	350	182	290	17 x 6	258	20	22	84	212	79	208	-	M20 x 1,5	B
VEF 2-1800	421	350	182	290	17 x 6	258	24	22	84	212	79	208	-	M20 x 1,5	B

VYF 2-60 M	186	130	72	109	8,5 x 4	104	12	8	47	77	35	-	OR 3350	M16 x 1,5	B
VAF 2-200 M	215	211	102	188	12 x 4	140	15	10	51	113	23	-	OR 4650	M20 x 1,5	B
VBF 2-350 M	279	215	120	188	12 x 4	176	15	11	66	130	37	-	OR 4650	M20 x 1,5	B
VCF 2-400 M	240	235	144	205	12 x 6	122	10	13	46	151	70	160	OR 4700	M20 x 1,5	A
VCF 2-600 M	240	235	144	205	12 x 6	122	15	13	46	151	70	160	OR 4700	M20 x 1,5	A

*We reserve the right to modify the specifications and dimensions without notice.

4 POLE CE

50 Hz-1500 rpm ~ 60 Hz-1800 rpm

*Please contact us for 60 Hz values.

MECHANICAL SPECIFICATIONS						ELECTRICAL SPECIFICATIONS			
RPM	TYPE	Centrifugal Force		Static Moment	Weight	Nominal Voltage	Max. Current	Capacitor	Max. Input Power
50 Hz		KG	N	kgmm	KG	V	A	µF	Kw
threephase 1500	VAF 4 - 80	80	785	32	7,8	230/400	0,52/0,30	-	0,15
	VBF 4 - 200	210	2060	84	11,9	230/400	0,72/0,42	-	0,17
	VCF 4 - 400	400	3924	159	17,3	230/400	1,30/0,75	-	0,35
	VCF 4 - 600	570	5592	227	19,3	230/400	1,30/0,75	-	0,35
	VDF 4 - 750	750	7353	290	30,3	230/400	1,73/1,00	-	0,6
	VDF 4 - 1100	1100	10791	437	33,3	230/400	2,16/1,25	-	0,7
	VEF 4 - 1800	1740	17069	692	64,5	230/400	4,76/2,75	-	1,25
	VEF 4 - 2100	2080	20405	827	67,5	230/400	5,71/3,30	-	1,4
single phase 1500	VAF 4 - 80 M	80	785	32	7,8	230	0,65	4	0,15
	VBF 4 - 200 M	210	2060	84	11,0	230	2,00	6	0,42

Working Moment = 2 x Static Moment

DIMENSIONS (mm)																
TYPE	A	B	C	D	H	E	F	G	I	L	M	N	O-Ring	Cable Entry	Figure	
VAF 4-80	215	211	102	188	12 x 4	140	24	10	51	113	23	-	OR 4650	M20 x 1,5	B	
VBF 4-200	279	215	120	188	12 x 4	176	36	11	66	130	37	-	OR 4650	M20 x 1,5	B	
VCF 4-400	298	235	142	205	12 x 6	122	44	13	77	151	100	160	OR 4700	M20 x 1,5	A	
VCF 4-600	324	235	142	205	12 x 6	122	60	13	90	151	113	160	OR 4700	M20 x 1,5	A	
VDF 4-750	360	280	176	230	15 x 6	189	44	15	89	188	82	185	OR 4800	M20 x 1,5	B	
				254	14 x 4									M20 x 1,5	B	
VDF 4-1100	398	280	176	230	15 x 6	189	64	15	113	188	95	185	OR 4800	M20 x 1,5	B	
				254	14 x 4									M20 x 1,5	B	
VEF 4-1800	506	350	200	290	17 x 6	258	70	22	130	212	117	208	-	M20 x 1,5	B	
VEF 4-2100	506	350	200	290	17 x 6	258	80	22	130	212	117	208	-	M20 x 1,5	B	
single phase	VAF 4-80 M	215	211	102	188	12 x 4	140	24	10	51	113	23	-	OR 4650	M20 x 1,5	B
	VBF 4-200 M	279	215	120	188	12 x 4	176	36	11	66	130	37	-	OR 4650	M20 x 1,5	B

Figure A

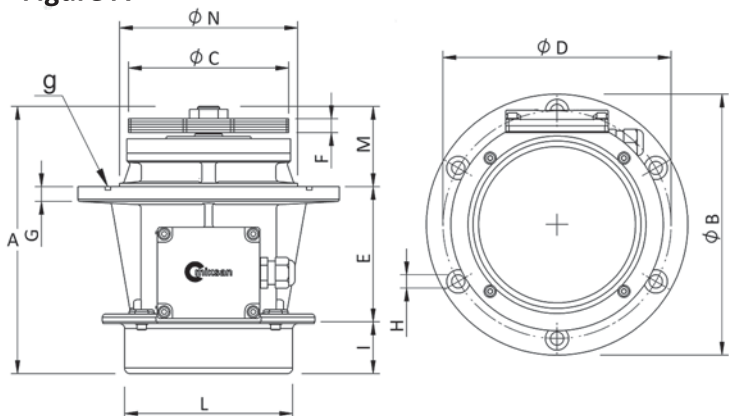
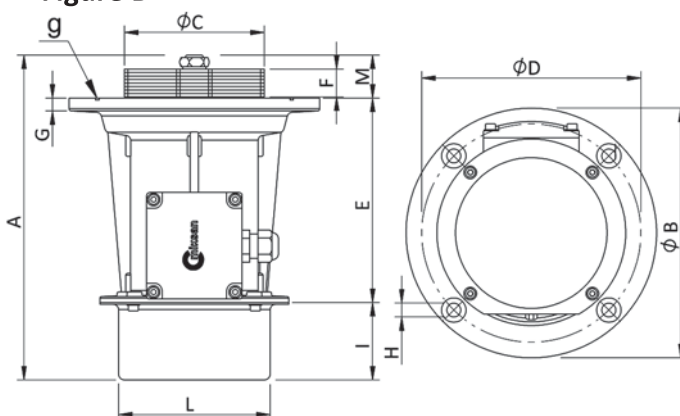

Figure B



*We reserve the right to modify the specifications and dimensions without notice.

VIBRATION SYSTEMS AND METHODS

The vibration methods the system that uses vibration motor can be classified as unidirectional or rotational method.

UNIDIRECTIONAL METHOD

Linear vibration force is obtained by aligning the centerline of two electrical vibration motors, each rotating in the opposite direction to the other with the same electro-mechanical characteristics, to the system's centerline.

At the unidirectional method the angle of incidence "i" of the force's line in relation to horizontal plane should be taken into consideration.

App : Amplitude

i : Angle of incidence

G : Center of gravity

i (angle)	Processes
6 - 12	Milling industry
25 - 30	Conveying, feeding, unloading, positioning
31 - 45	Separating
45 - 80	Fluidized beds

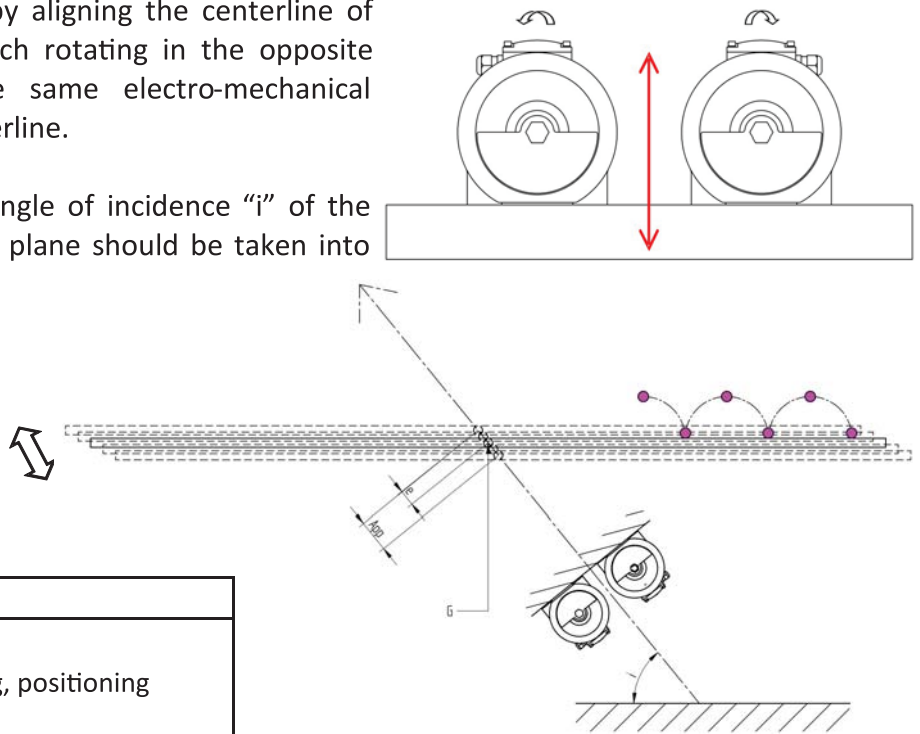

ROTATIONAL METHOD

The rotational vibration is obtained when vibrating force directed in all direction through 360°, by a single vibration motor.

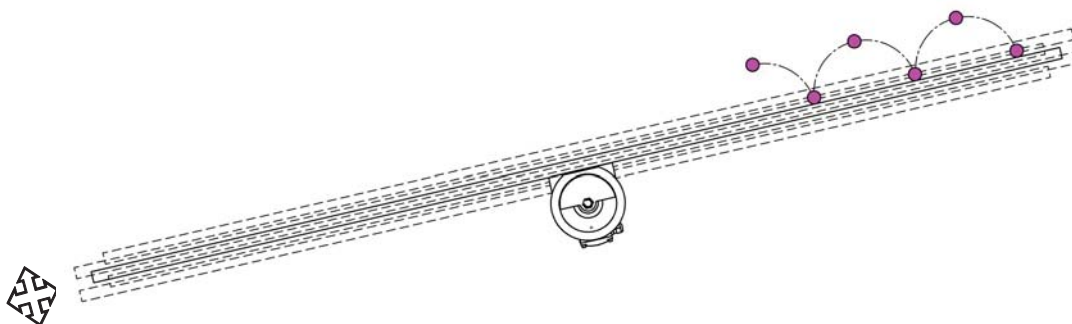
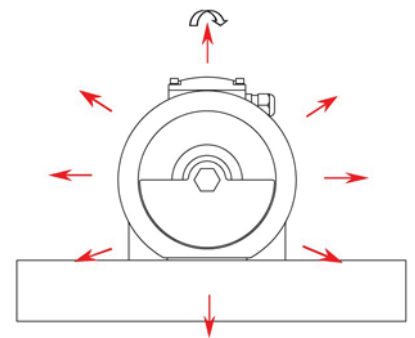

Application	Material		Speed	Vibration Force		Acceleration
	Specific Weight	Size	n (rpm)	Rotating	Linear	a
Separating Conveying Sieving Positioning Grading Sizing Extracting Feeding	High	Fine	1500-3000		●	4~9
		Medium	1000-1500		●	4~6
		Coarse	750-1500		●	3.5~4.5
	Low	Fine	1500		●	5~7
		Medium	1000		●	4~5.5
		Coarse	750-1000		●	3.5~5.5
Filter cleaning	H/L	F/M/C	1500-3000	●		2~3
Separators (for mills)	H/L	F/M/C	750-1000		●	2~4
Slackening and emptying material in silos, hoppers.	H/L	F/M/C	3000	●		* (1)
Fluidized beds	H/L	F/M/C	750-1000	●		2~4
Vibrating beds	H/L	F/M/C	1500-3000	●		0.7~2
Compacting	H/L	F/M/C	1500-6000	●	●	2~5
Compacting concrete	-	-	3000-9000	●	●	1~2
Accelerated ageing	-	-	400-9000	●	●	0.5~24

*(1) Centrifugal force = Weight of material contained in the vibrating apparatus conic part x 0.1 veya 0.2

How to choose correct vibration motor

I. Method:

- Choose the vibration method (unidirectional or rotational) from the table according to the application.

- Choose the speed from the table according to the application.

- According to the amplitude, centrifugal force (F_c) or statical moment (M) is calculated by using below formulas.

$$F_c = e \times m_t \times \left(\frac{n}{300} \right)^2 \quad [\text{N}]$$

$$M = e \times m_t \quad [\text{kg.mm}]$$

$$e = \frac{App}{2} \quad [\text{mm}]$$

App : Amplitude [mm]

m_t : System mass (including vibration motor mass [kg]

$$m_t = m_{system} + (m_{vib.motor} \times \text{number of motor})$$

e : Eccentricity [mm]
n : Speed [rev/min]

- If the unidirectional method is chosen, calculated centrifugal force or moment should be divided to the number of motors .

- According to the calculated values the vibration motor is chosen from the catalogue.

- On the last step you have to check the vibration motor by using the formula that is shown below. If the calculated acceleration value is match the values that is on table, the motor is suitable.

$$a = \frac{F_c}{m_t} \times \text{number of motor}$$

II. Method:

If the mass of system is known;

- Choose the vibration method (unidirectional or rotational) from the table according to the application.

- Choose the speed from the table according to the application.

- Choose one of the vibration motor from catalogue according to the speed. And specify the centrifugal force and mass of that vibration motor.

- Calculate the mass of system using below formula. Please be careful about the number of motors, if you choose unidirectional method, mass of the motor should multiply by 2. Likewise, the centrifugal force of motor should multiply by 2.

$$m_t = m_{\text{system}} + (m_{\text{vib. motor}} \times \text{number of motor})$$

- Calculate the acceleration value.

$$a = \frac{F_c}{m_t} \times \text{number of motor}$$

- Match the calculated acceleration value from the table. If the Acceleration value doesn't match, choose another vibration motor and do it again the all steps.

APPLICATIONS

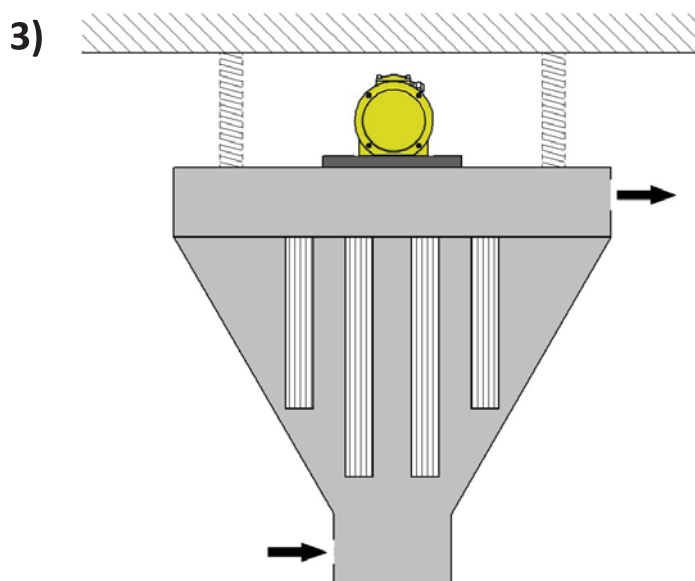
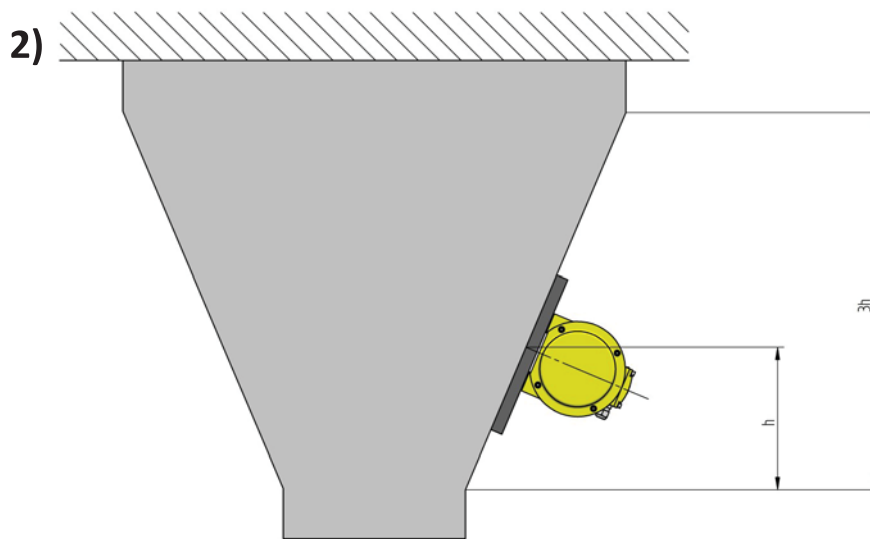
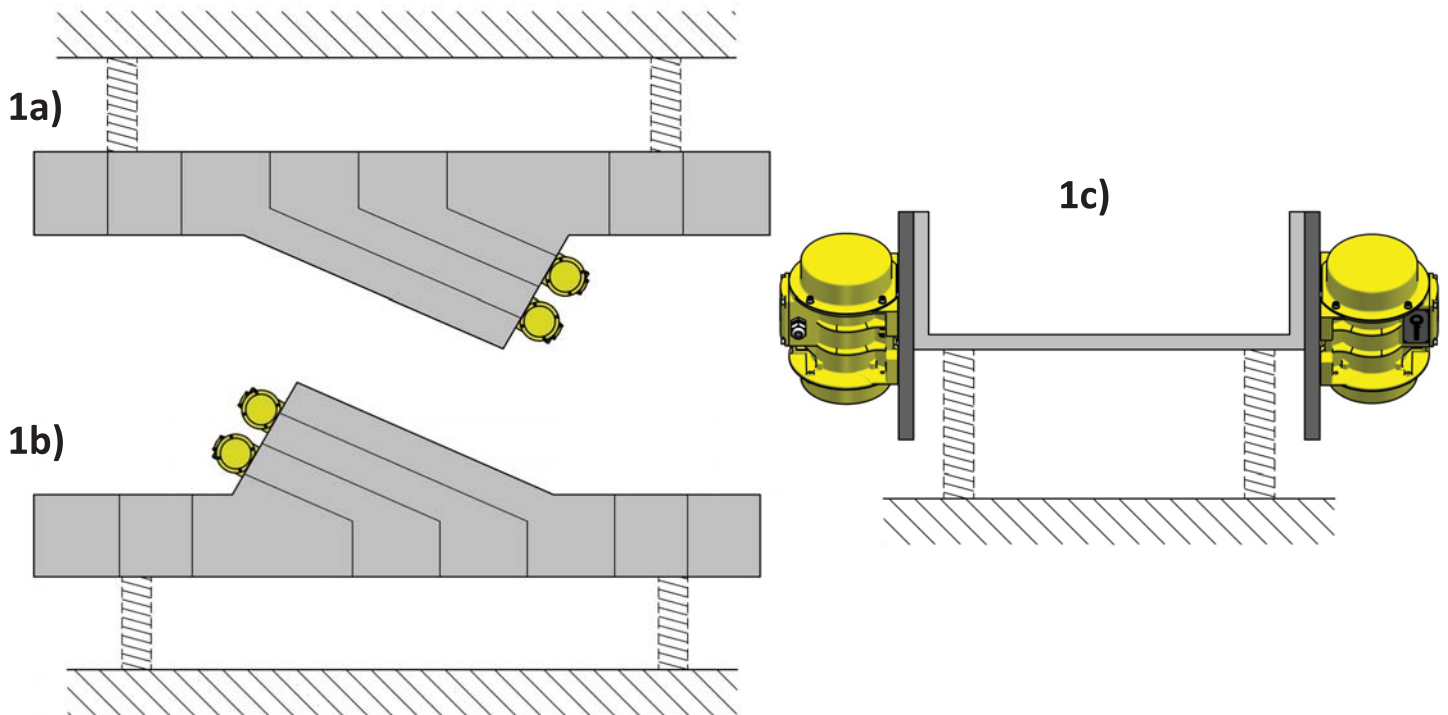

- 1a, 1b, 1c : Linear conveying systems,
- 2 : Hoppers, silos applications;
- 3 : Filter cleaning applications.

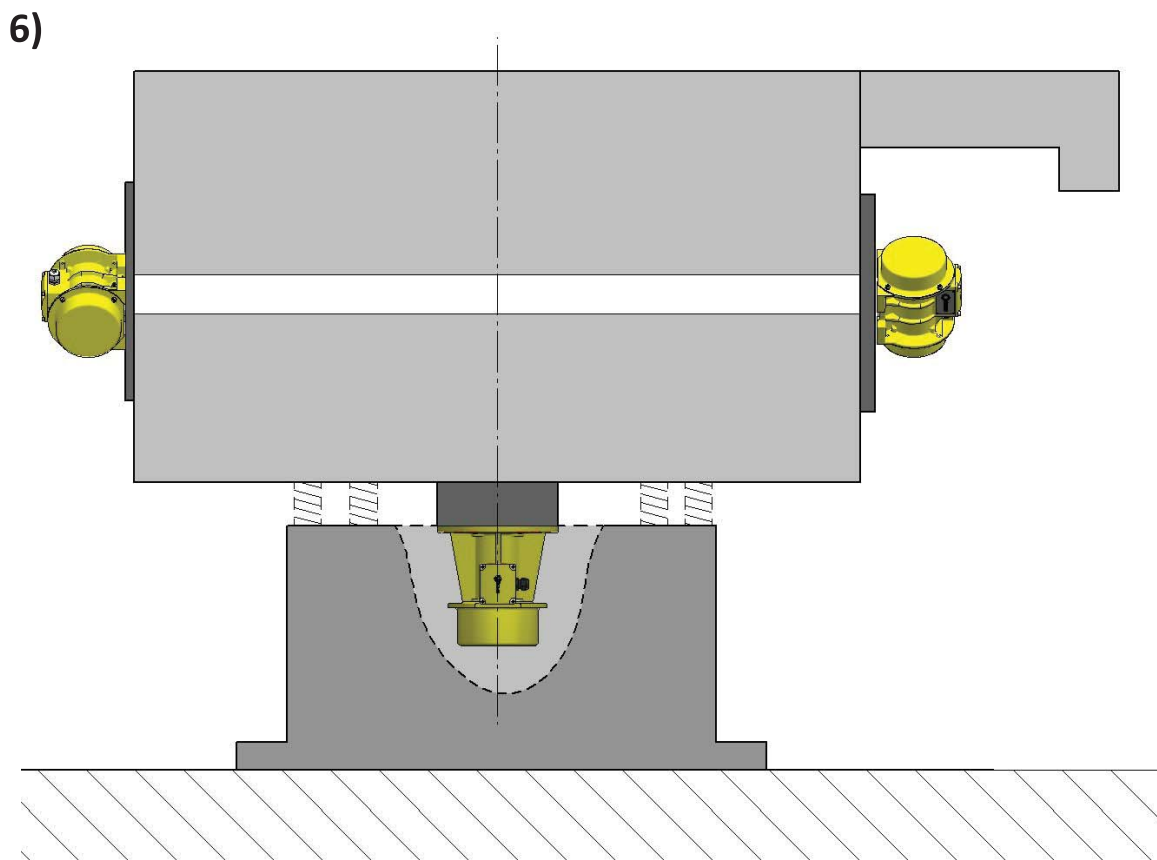
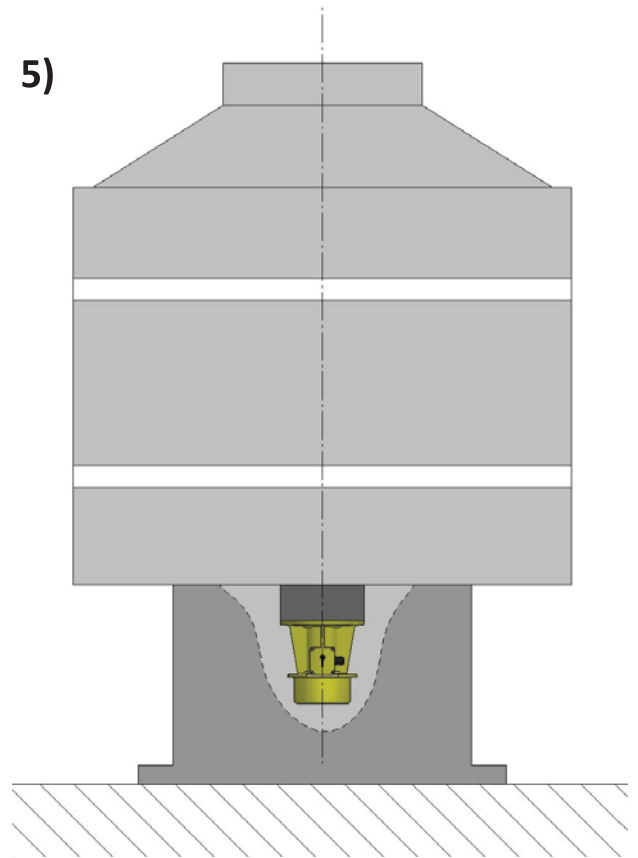
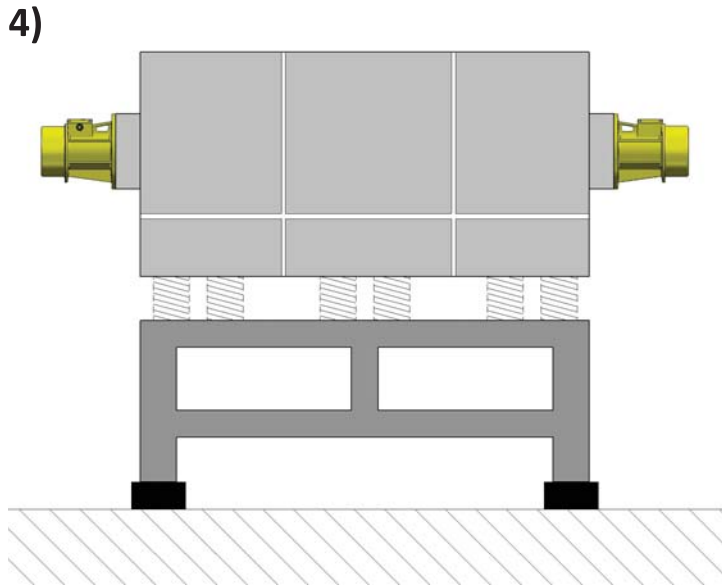

- 4 : Sieving applications with flanged vibration motors;

- 5 : Circular sieving application with flanged vibration motors;

- 6 : Circular conveying application with single flanged vibration motor or two pieces foot-mounted vibration motors.

**IEP ENERGY PETROLEUM INSTITUTE**

[1]

EC-Type Examination Certificate[2] **Equipment or Protective Systems Intended for use in Potentially Explosive Atmospheres****Directive 94/9/EC**[3] EC – Type Examination Certificate Number : **IEP 14 ATEX 0262**[4] Equipment : **Vx Series Vibration Motors**[5] Manufacturer : **MİKSAN MOTOR SANAYİ VE TİCARET A.Ş.**[6] Address : **Beylikdüzü Organize San. Böl. Bakır ve Pirinç Sanayicileri Sitesi Menekşe Caddesi No:1
Beylikdüzü / İSTANBUL – TURKEY**

[7] This equipment or protective system and any of acceptable variation thereto is specified in the schedule to this certificate and the documents therein referred to.

[8] The IEP Uluslar Arası Enerji Petrol Gözetim , Sertifikasyon ve Teknik Hizmetler Organizasyonu Tic. Ltd. Sti. , notified body number 2284 in accordance with of the Council Directive 94/9/EC of 23 March 1994 certifies that this equipment or protective system has been found to comply with the Essential Health and Safety Requirements relating to the design and construction of equipment and protective systems intended for use in potentially explosive atmospheres given in Annex II to the Directive. The examination and test results are recorded in confidential Report N : IEP - RP.Ex - 10. 651 date 09.10.2014



[9] Compliance with Essential Health and safety requirements has been assured by compliance with ;

EN 60079-0/2009 ; EN 60079-31/2009

[10] If the sign “ X “ is placed after the certificate number , it indicates that the equipment or protective system is subject to special conditions for safe use specified in the schedule to this certificate.

[11] This EC-Type Examination Certificate relates only to the design examination and testing of the specified equipment or protective system in accordance to the directive 94/9/EC. Further requirements of the directive apply to the manufacturing process and supply of this equipment or protective system. These are not covered by this certificate.

[12] The marking of the equipment or protective system shall include the following :

 **II 2 D Ex tb IIC (T 120 °C) Db , IP66****Responsible person :**Nurettin Terzioğlu
Head of certification body**Date of issue : 15.10.2014**IEP Uluslar Arası Enerji Petrol Gözetim , Sertifikasyon ve Teknik Hizmetler Organizasyonu Tic. Ltd. Sti.
MTK Sitesi 5746/1 Sok. No:9 K:2 Camdibi – İZMİR / TURKEY Tel : +90 232 431 17 45 46 & Fax : +90 232 431 17 30
Fr:45 Number of Pages : 1 / 6This certificate is granted subject to the general conditions of the IEP Energy Petroleum Institute.
This certificate may only be reproduced in its entirety and without any change , schedule included.

**IEP ENERGY PETROLEUM INSTITUTE**

[1]

Internal Production Control Certificate[2] **Equipment or Protective Systems Intended for use in Potentially Explosive Atmospheres****Directive 94/9/EC**[3] EC – Type Examination Certificate Number : **IEP 16 ATEX 0384**[4] Equipment : **Vxx and Vyx Series Micro Vibration Motors**[5] Manufacturer : **MİKSAN MOTOR SANAYİ VE TİCARET A.Ş.**[6] Address : **Beylikdüzü Organize San. Böl. Bakır ve Pirinç Sanayicileri Sitesi Menekşe Caddesi No:1
Beylikdüzü / İSTANBUL – TURKEY**

[7] This equipment or protective system and any of acceptable variation thereto is specified in the schedule to this certificate and the documents therein referred to.

[8] The IEP Uluslararası Enerji Petrol Gözetim , Sertifikasyon ve Teknik Hizmetler Organizasyonu Tic. Ltd. Sti. , notified body number 2284 in accordance with of the Council Directive 94/9/EC of 23 March 1994 certifies that this equipment or protective system has been found to comply with the Essential Health and Safety Requirements relating to the design and construction of equipment and protective systems intended for use in potentially explosive atmospheres given in Annex II to the Directive. The examination and test results are recorded in confidential Report N : IEP - RP.Ex - 10.867 date 12.02.2016

[9] Compliance with Essential Health and safety requirements has been assured by compliance with ;

EN 60079-0/2012 ; EN 60079-31/2009

[10] If the sign “ X “ is placed after the certificate number , it indicates that the equipment or protective system is subject to special conditions for safe use specified in the schedule to this certificate.

[11] This Internal Production Control Certificate relates only to the design and the construction of the specified equipment in accordance with directive 94/9/EC. Further requirements of the directive apply to the manufacturing process and supply of this equipment. These are not covered by this certificate. The manufacturer of this equipment on the manufacturing process, take all necessary measures to comply with the regulation. Validity date 10 year. If standard or product change, this certificate is invalid.

[12] The marking of the equipment or protective system shall include the following :

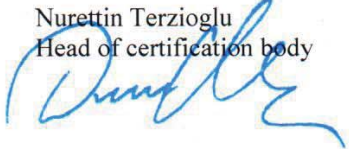
 **II 3 D Ex tc IIIC (T 100 °C) Dc , IP65****Responsible person :**Nurettin Terzioglu
Head of certification body**Date of issue : 17.02.2016**IEP Uluslararası Enerji Petrol Gözetim , Sertifikasyon ve Teknik Hizmetler Organizasyonu Tic. Ltd. Sti.
MTK Sitesi 5746/1 Sok. No:9 K:2 Camdibi – İZMİR / TURKEY Tel : +90 232 431 17 45 46 & Fax : +90 232 431 17 30
Fr:65 Number of Pages : 1 / 3This certificate is granted subject to the general conditions of the IEP Energy Petroleum Institute.
This certificate may only be reproduced in its entirety and without any change , schedule included.

Fax : +90 212 279 55 67
E-mail : info@miksánmotor.com

VIBRATION MOTORS QUOTATION FORM

Application :

Motion : Circular Linear

Total mass of System : kg

Material Specifications

Material :

Density : kg/m³

Size of the Material : mm

Elektrical Specifications : - Voltage ; 3 Phase 1 Phase
230/400 V 230 V Other : V
- Frequency ; 50 Hz 60 Hz Other : Hz

Notes :
.....
.....
.....

Customer Informations

Company :

Address :

Phone :

E-mail :@.....

Date :



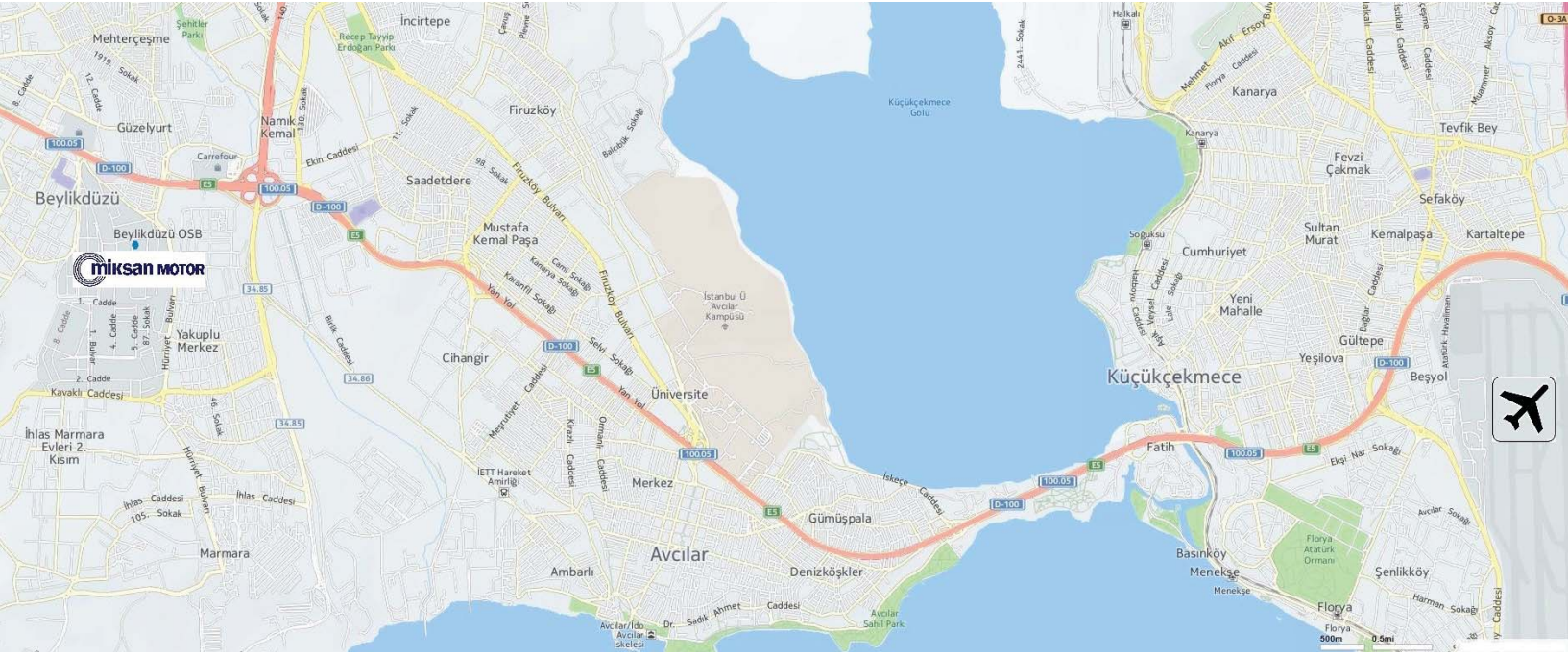

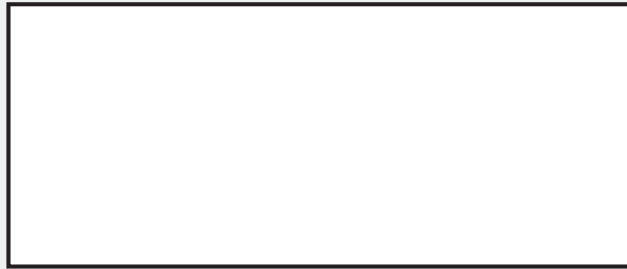

MİKSAN MOTOR SAN. VE TİC. A.Ş.
B.O.S.B. Bakır ve Piriç Sanayicileri Sitesi
Menekşe Cad. No:1 Beylikdüzü - İstanbul / TÜRKİYE
Tel: +90 212 284 64 00
Fax: +90 212 279 55 67
e-mail: info@miksanmotor.com
web: www.miksanmotor.com